

INSTALLATION INSTRUCTIONS
for SINGLE PLUNGER SNAP ACTION PUSHBUTTON SWITCHES

02761-001	02761-002	02761-003	02761-004	02919-012
04917-012	04917-312	04948-001	04948-002	04948-003
04948-004	04957-001	04957-003	04957-012	04960-512

The following switches marked with a (*) = Large Mounting Plan.

04917-102*	04917-112*	04917-212*	04917-712*	04917-812*
------------	------------	------------	------------	------------

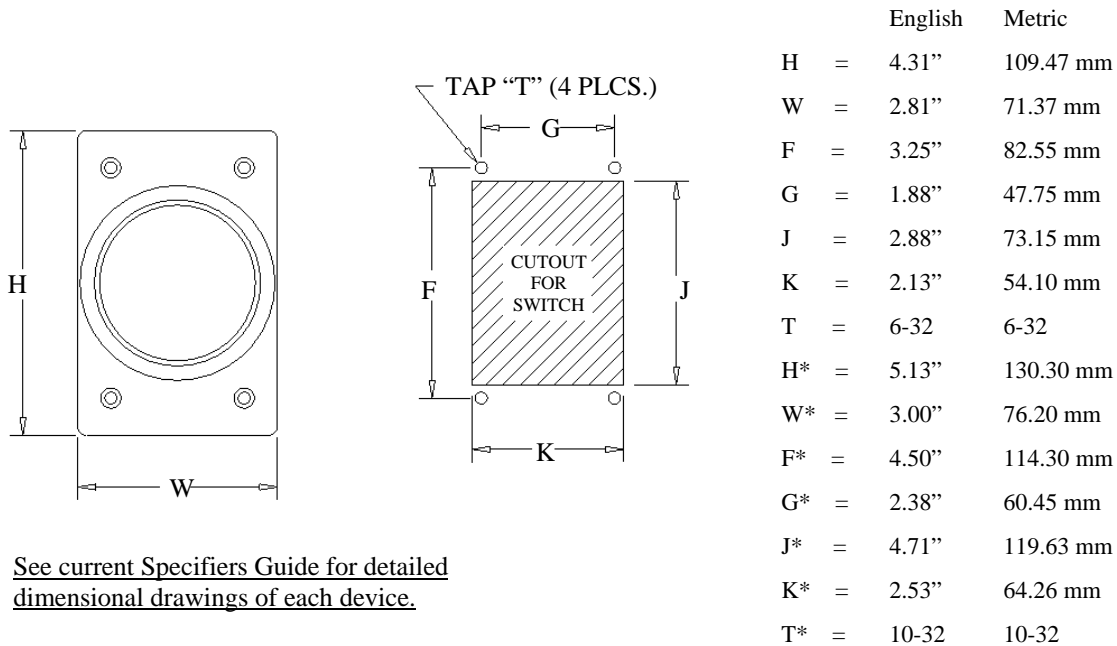

Note: See current Specifiers Guide for detailed dimensional drawings of each device.

* Large Mounting Plan Only

INSTALLATION:

1. Observe all SAFETY REQUIREMENTS and PROCEDURES during installation, set-up and running.
2. N.E.C. and local wiring codes MUST be followed at all times.
3. The cable switch MUST be mounted on or in an enclosure (Mounting screws are supplied with each switch).
4. Before wiring be sure to place the supplied gasket on the switch.
5. Wire as required, torque each used terminal screw to 18 in.-lbs. (20.7 cm-kg).
6. After wiring, place the switch into the enclosure taking care to route the wires away from the back of the switch so that they do not become entangled and interfere with the operation of the device.
7. Secure the switch with the mounting screws. Torque to (approx. 7 in./lbs. ~8.06 cm-kg for #6's or 15 in.-lbs. ~17.3 cm-kg for #10's).
8. Wiring SHOULD be through a control circuit.
9. After applying power to the control circuit, operate the device to check for proper installation.

MAINTENANCE:

1. Regular Preventive Maintenance inspections are recommended.
2. Some conditions to watch for are:
 - a. Physical damage to the device.
 - b. Frayed wiring.
 - c. Any loose components.
 - d. Any worn components.
3. If other assistance is desired please contact the factory.

SPECIFICATIONS / APPROVALS
for SINGLE PLUNGER SNAP ACTION PUSHBUTTON SWITCHES

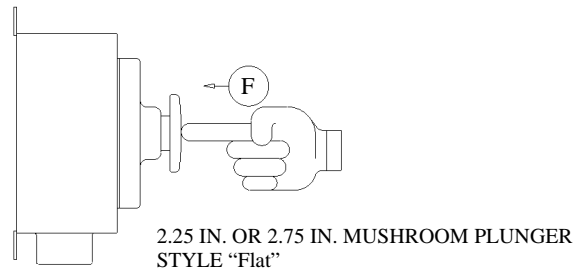
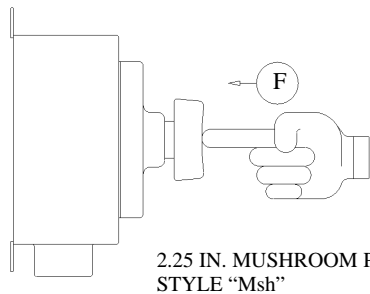

F = The value of force, in pounds, which trips the switch.

Catalog Number	Contact Arrangement	Plunger Operator			Integral Ring Guard or Shield	Positive Break	F LBS.	F Kg.
		Style	Color	Material				
02761-001	#64 (2NO + 2NC)	2.25 in. Msh.	Black	Zinc	No	No	3.7	1.7
02761-002	#64 (2NO + 2NC)	2.25 in. Msh.	Red	Zinc	No	No	3.7	1.7
02761-003	#64 (2NO + 2NC)	2.25 in. Msh.	Green	Zinc	No	No	3.7	1.7
02761-004	#64 (2NO + 2NC)	2.25 in. Msh.	Yellow	Zinc	No	No	3.7	1.7
02919-012	#64 (2NO + 2NC)	2.25 in. Msh.	Chrome	Zinc	No	No	3.7	1.7
04917-012	#64 (2NO + 2NC)	2.25 in. Flat	Chrome	Zinc	No	No	3.7	1.7
04917-102	#64 (2NO + 2NC)	2.75 in. Flat	Red	Zinc	No	No	3.5	1.6
04917-112	#64 (2NO + 2NC)	2.75 in. Flat	Chrome	Zinc	No	No	3.5	1.6
04917-212	#64 (2NO + 2NC)	2.75 in. Flat	Chrome	Zinc	Yes (RG)	No	3.5	1.6
04917-312	#64 (2NO + 2NC)	2.75 in. Flat	Chrome	Zinc	No	No	3.7	1.7
04917-712	#64 (2NO + 2NC)	2.75 in. Flat	Chrome	Zinc	Yes (RG)	No	2.0	0.9
04917-812	#64 (2NO + 2NC)	2.75 in. Flat	Chrome	Zinc	No	No	2.0	0.9
04948-001	#64 (2NO + 2NC)	2.25 in. Msh.	Black	Plastic	No	No	3.5	1.6
04948-002	#64 (2NO + 2NC)	2.25 in. Msh.	Red	Plastic	No	No	3.5	1.6
04948-003	#64 (2NO + 2NC)	2.25 in. Msh.	Green	Plastic	No	No	3.5	1.6
04948-004	#64 (2NO + 2NC)	2.25 in. Msh.	Yellow	Plastic	No	No	3.5	1.6
04957-001	#64 (2NO + 2NC)	2.75 in. Flat	Black	Zinc	No	No	1.9	0.9
04957-003	#64 (2NO + 2NC)	2.75 in. Flat	Green	Zinc	No	No	1.9	0.9
04957-012	#64 (2NO + 2NC)	2.75 in. Flat	Chrome	Zinc	No	No	1.9	0.9
04960-512	#64 (2NO + 2NC)	2.25 in. Msh.	Chrome	Steel	Yes (Sh)	No	3.8	1.7

These switches comply with:	UL listed PER UL-508; File E 58589 CSA certified PER CSA—C 22.2 No. 14-M1987; File LR 3648 Demko certified per EN 60947-1:1997; EN 60947-5-1: 1997; File FI 17205 CE Marked
IEC Ratings:	Utilization = A 600, AC 15; N 300, DC 13; Ue = 600 vAC; Ue = 250 vDC, Ui = 600 vAC, Uimp = 2.5 kV; Ith = 10A
Temperature:	Operating = 0°C to +55°C (-32°F to +131°F); Storage = -40°C to +85°C (-40°F to +185°F)
Mechanical Life Rating:	1,000,000 operations

WARNING—DANGER

These products should only be used where point-of-operation guarding devices have been properly installed and maintained so that all appropriate OSHA and ANSI B11.1 regulations and standards are met. Misapplication of these products on machinery lacking effective point-of-operation safeguards can cause serious injury to the operator of that machinery.