

# Carlton®

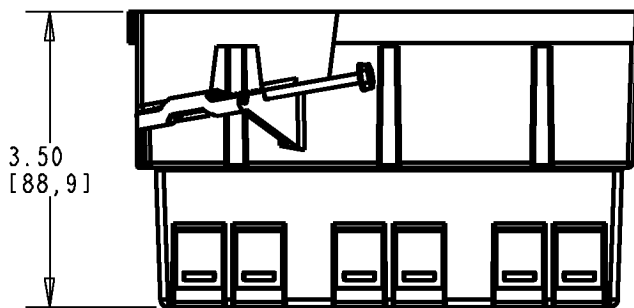
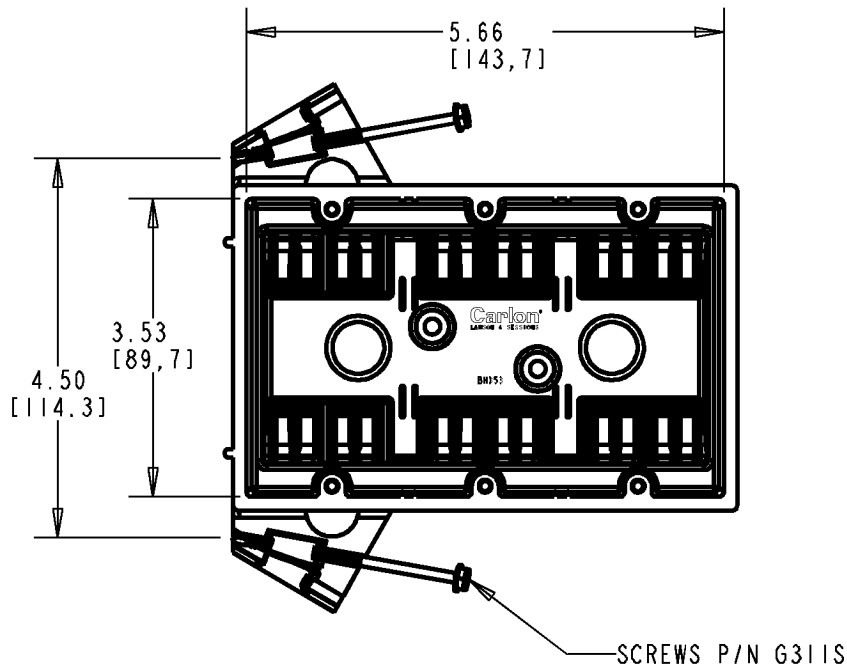
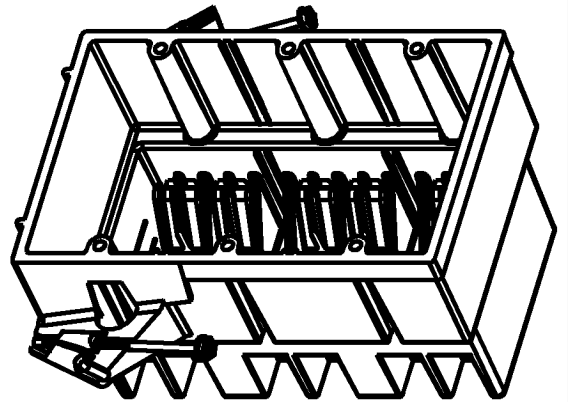

WIRE GA. / CONDUCTORS  
 26 / 14  
 23 / 12  
 20 / 10

P/N BH353S

### GENERAL NOTES

1. ALL DIMENSIONS ARE FOR REFERENCE ONLY.
2. DIMENSIONS IN BRACKETS [ ] ARE IN METRIC UNITS.

### REVISIONS

\*\*\* SEE ERN ( \*\*\*\* ) FOR APPROVAL SIGNATURES & RELEASE DATE.  
 PROJECT NO: \*\*\*\*

**Thomas & Betts**  
 www.tnb.com

DESCRIPTION: **3 GANG SUPER BLUE  
 OUTLET & SWITCH BOX - 52 CU. IN. VOL.**

ORIGINAL PROJECT NO / ( ERN NO )  
 / ( )

SHEET NO:  
 1 OF 2

REV. NO:  
**B**

DRAWING NO:  
**WSD-AC03644**

# Carlton®

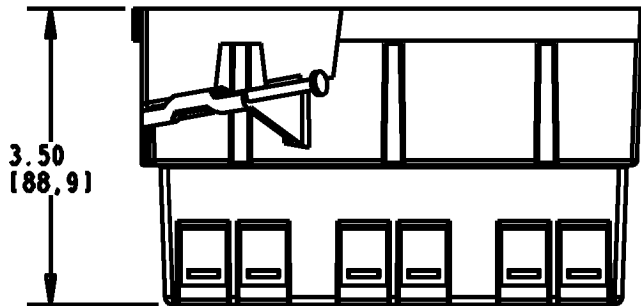
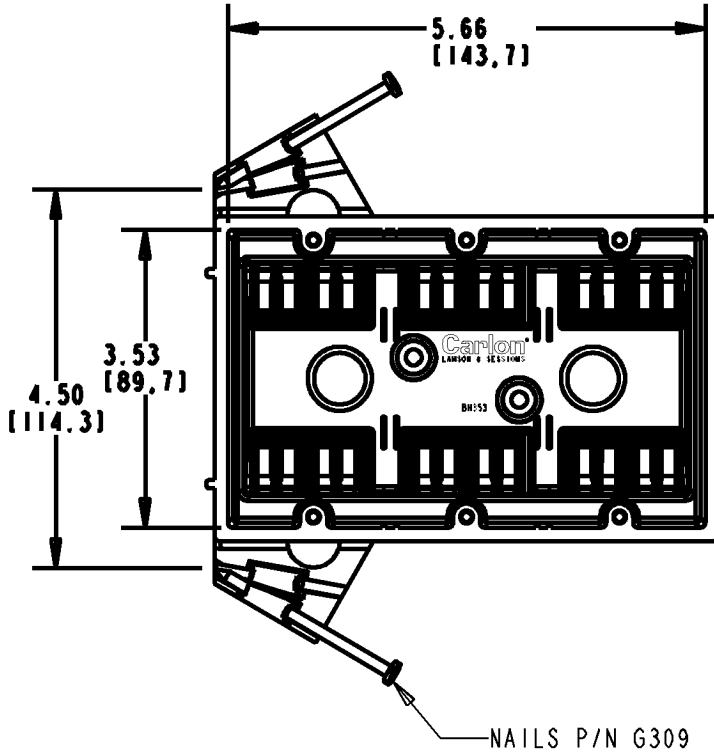
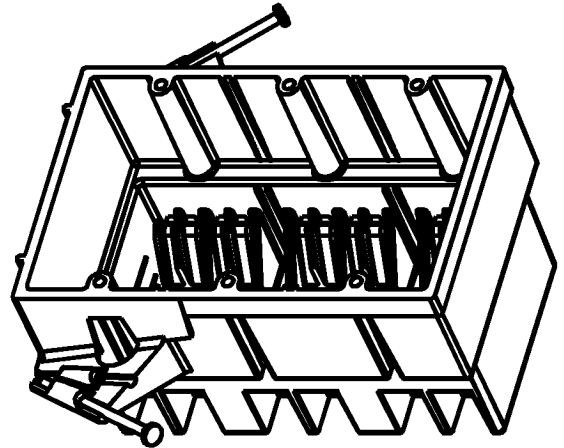

WIRE GA. / CONDUCTORS

26 / 14  
23 / 12  
20 / 10

P/N BH353A

**Thomas & Betts**  
www.tnb.com

DESCRIPTION: **3 GANG SUPER BLUE  
OUTLET & SWITCH BOX - 52 CU. IN. VOL.**

SHEET NO:  
2 OF 2

REV. NO:  
B

DRAWING NO:  
**WSD-AC03644**