

PHILIPS
Stonco

Wall mount

LytePro LED Sconce

LPW7



Project: _____
Location: _____
Cat.No: _____
Type: _____
Quantity: _____
Notes: _____

The Philips Stonco LytePro LED Small Wall Sconce LPW7 features outstanding value in a compact, architectural design. This wall sconce offers chip-on-board (COB) LED technology for outstanding energy savings with good photometric performance. LPW7 is ideal for entryways, corridors, facade and other wall/surface lighting applications.

Stocked luminaires – Ordering guide¹

Catalog Number	Description	Master Pack, Qty	UPC Code
LPW7-8BZ	LPW7, 14W COB LED, 350mA, 4000K, 120-277V, Bronze textured paint	6	786034960441
LPW7-8DGY	LPW7, 14W COB LED, 350mA, 4000K, 120-277V, Dark gray textured paint	6	786034960458
LPW7-1BZPCB	LPW7, 14W COB LED, 350mA, 4000K, 120V, Bronze textured paint, w/button photocell	6	786034960472

Stocked accessories - Ordering guide (Must be ordered separately)

Catalog Number	Description	Master Pack, Qty	UPC Code
LPWCVRPLT-BZ	LPW Universal wall cover mounting plate, Bronze textured paint	(none)	786034960618

Description of catalog codes

Family	Drive current	Voltage	Finish	Options
LPW7 = LytePro 7 LED Small Wall Sconce	(Blank - standard 350mA drive current)	8 = 120-277V 1 = 120V	BZ = Bronze textured paint DGY = Dark gray textured paint	PCB = Button photocontrol

1. Color availability and options vary by model; consult stock luminaires ordering guide above.

LPW7 LytePro LED Small Wall Sconce

Features

- LPW7 wall sconce delivers 1,154 lumens at 14W, with an efficacy of 82 lumens per watt.
- 14W LED may effectively replace 60-200W incandescent, 26-42W compact fluorescent and 35-39W HID luminaires.²
- 4000K neutral white at 70 CRI (minimum) is standard.
- Offers two in-stock colors on standard units.*
- 5-year limited warranty; see philips.com/warranties for specific details.

Performance/Specifications

Distribution	Type 2
Initial Lumens (4000K)*	1,154
Average Wattage*	14
Lumens/Watt	82
BUG Rating*	B1/U0/G1
Luminaire Weight	~4lbs (1.8Kg)

Ratings/Approbations/Certifications

Ingress Protection	IP65 Optical
DLC Listed	DLC QPL
cETLus	Certified for use in wet locations
Rated Ambient Temperature	-30°C (-22°F) to 40°C (104°F)

Fixture Dimensions³

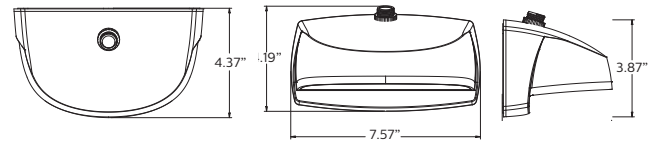

Accessory Dimensions (ordered separately)

LPWCVRPLT-BZ LPW Universal wall cover mounting plate, 0.08" aluminum, bronze textured paint (used to cover larger pre-existing opening or surfaces, field installed). Offers same J-Box pattern as luminaire or may lagged to wall using (4) knockouts.

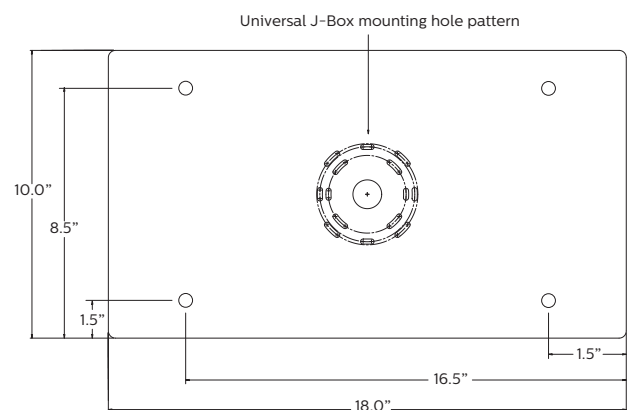

2. Comparable equivalency to HID and other lamp sources depends on multiple criteria including mounting height, fixture spacing, efficiency, performance and classification of the luminaire being replaced and application lighting criteria required for the given project.
3. PCB shown for placement only, available on specific models only (see ordering guide).

Distribution Pattern

LPW7 - 8' MOUNTING HEIGHT

MOUNTING HEIGHT	6'	8'	10'
MULTIPLIER	1.78	1.0	0.64

- 4. Isolines shown at 2.0, 1.0, 0.5, & 0.2 FC.
- 5. Choose mounting height. Use MULTIPLIER (X) EXISTING FC VALUE = NEW FC VALUE.
- 6. FC values are based on initial lumen output.
- 7. Gridline spacing is in units of chosen mounting height.

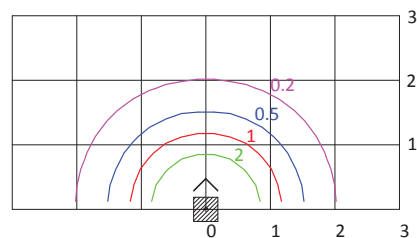

LPW7 LytePro LED Small Wall Sconce

General Description

The Philips Stonco LytePro LED Small Wall Sconce LPW7 combines excellent performance, design and value to meet the needs of the energy and budget conscious. The LPW7 is available for use in downward facing, surface wall mount applications, over recessed j-boxes or where power can be directly fed through back surface, whereby connections splices can be made inside the luminaire housing. Three SKU's are available as in-stock configurations (2-day quick ship). Two standard finishes. 120V button photocell is available in bronze only.

Housing

Die-cast housing houses both the LED and driver assemblies. Design incorporates an integrated heat sink to maximize thermal performance and reliability. Backplate is corrosion free, composite polycarbonate, with built-in level bubble, offers integral interlocking hook and mount design for easy installation.

Mounting

Easy interlocking hook and mount housing/backplate design for easy installation. Mounts over 3.5", 4" octagonal j-boxes and single gang switch boxes (mounted horizontally) or can be directly lagged to surface. Ensure proper steps for gasket/sealing luminaire to surface.

IP Rating

Optical compartment is IP65 rated.

LED Board and Array

Provides up to 82 lm/W at the system level. Standard color temp is 4000K +/- 250K, minimum 70 CRI.

Electrical

Driver efficiency (>90% standard). 120-277V. Temp range: -30°C (-22°F) to 40°C (104°F). Open/short circuit protection. RoHS compliant.

Listings

Product is cETLus listed suitable for Wet Locations. Suitable for use in ambients from -30°C to 40°C (-22°F to 104°F). DesignLights Consortium® qualified. Stocked SKUs of the LPW family are made in China.

Finish

Each luminaire receives a fade and abrasion resistant, electrostatically applied, thermally cured, triglycidal isocyanurate (TGIC) textured polyester powdercoat finish. Two standard colors are available: Dark Grey, and Bronze. Specific options are only available in bronze.

Warranty

LPW7 luminaires, the LED arrays, and the drivers are all covered by a 5-year limited warranty. See philips.com/warranties for details.

LED Performance:

PREDICTED LUMEN DEPRECIATION DATA^{4,6}

Ambient Temp. °C	Calculated L70 hrs ⁵	Reported L70 Per TM-21 ^{5,6}	Calculated Lumen Maint. % @60,000 hrs
up to 40°C	>200,000 hrs	>36,000 hrs	97%

4. Calculated performance derived from LED manufacturer's data and engineering design estimates, based on IESNA LM-80 methodology. Actual experience may vary due to field application conditions.

5. L70 is the predicted time when LED performance depreciates to 70% of initial lumen output.

6. Reported per IESNA TM21-11. Published L70 hours limited to 6 times actual LED test hours.



© 2014 Koninklijke Philips N.V. All rights reserved. Philips reserves the right to make changes in specifications and/or to discontinue any product at any time without notice or obligation and will not be liable for any consequences resulting from the use of this publication. philips.com/luminaires



Philips Lighting North America Corporation
200 Franklin Square Drive, Somerset, NJ 08873
Tel. 855-486-2216

Imported by: Philips Lighting,
A division of Philips Electronics Ltd.
281 Hillmount Rd, Markham, ON, Canada L6C 2S3
Tel. 800-668-9008