

M13032 1

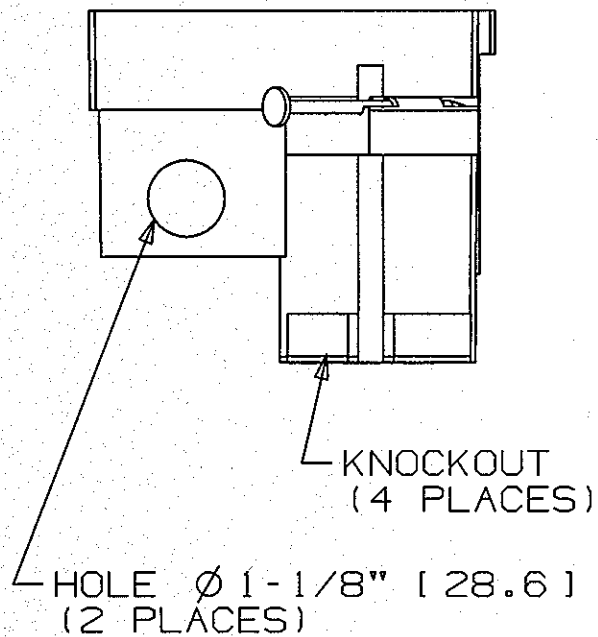
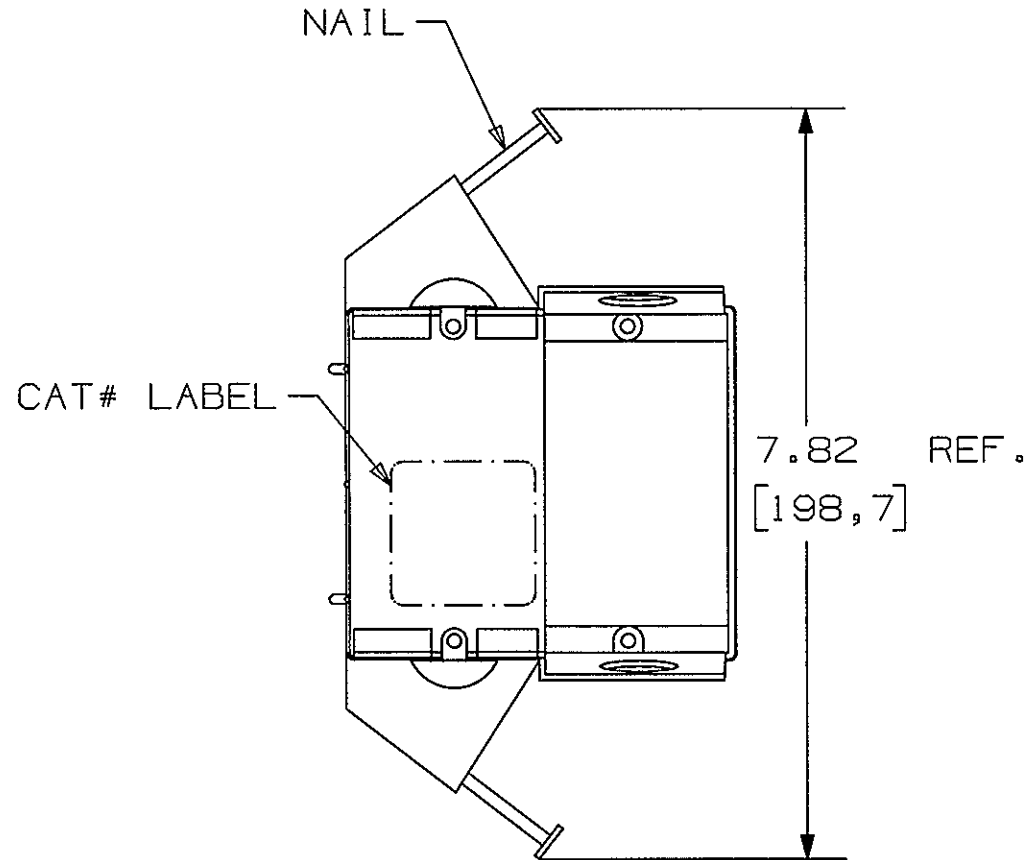
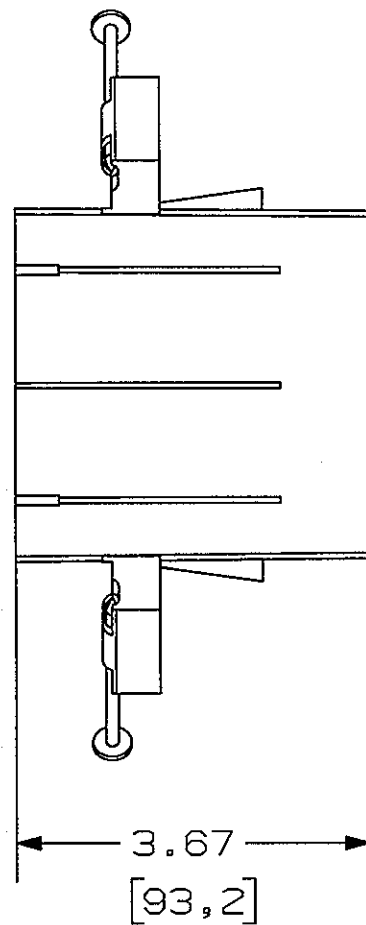
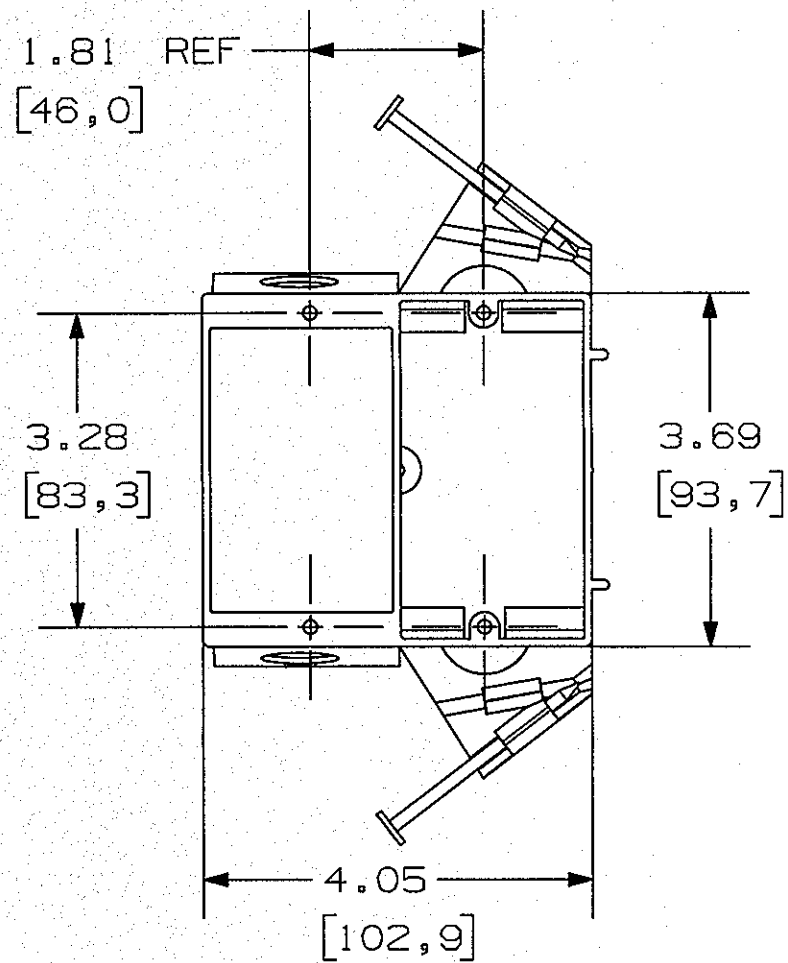

NOTES:
 1. ALL DIMENSIONS ARE IN INCHES [mm].
 2. TO BE USED WITH HUBBELL RECESS RECEPTACLE CAT.#: RR1512 OR RR1514 SERIES.

LIST OF PARTS

DESCRIPTION	MATERIAL	FINISH
BOX	THERMOPLASTIC	
NAIL	STEEL	ZN PLATE

DIMENSION SHEET FOR CAT. NO.

RR1500

REPAIRABLE NON-REPAIRABLE

B

M-13032 1

1	NEW RELEASE PER DCN #21107. DL	APP	DATE

THE DESIGN AND DIMENSIONS OF THE PRODUCT SHOWN ON THIS DRAWING ARE SUBJECT TO CHANGE WITHOUT NOTICE

TITLE
 PLASTIC BOX, RECESS,
 2 GANG, DUAL VOLTAGE

TOLERANCES UNLESS OTHERWISE SPECIFIED .XX = ±.01 .XXX = ±.005 ANGLES = ±2°	WIRING DEVICE-KELLEMS HUBBELL INCORPORATED SHELTON, CT	
	DR. BY DL	APP. BY SM
	TR. BY	SCALE 1:2
	CHK. BY	DATE 03/16/15