

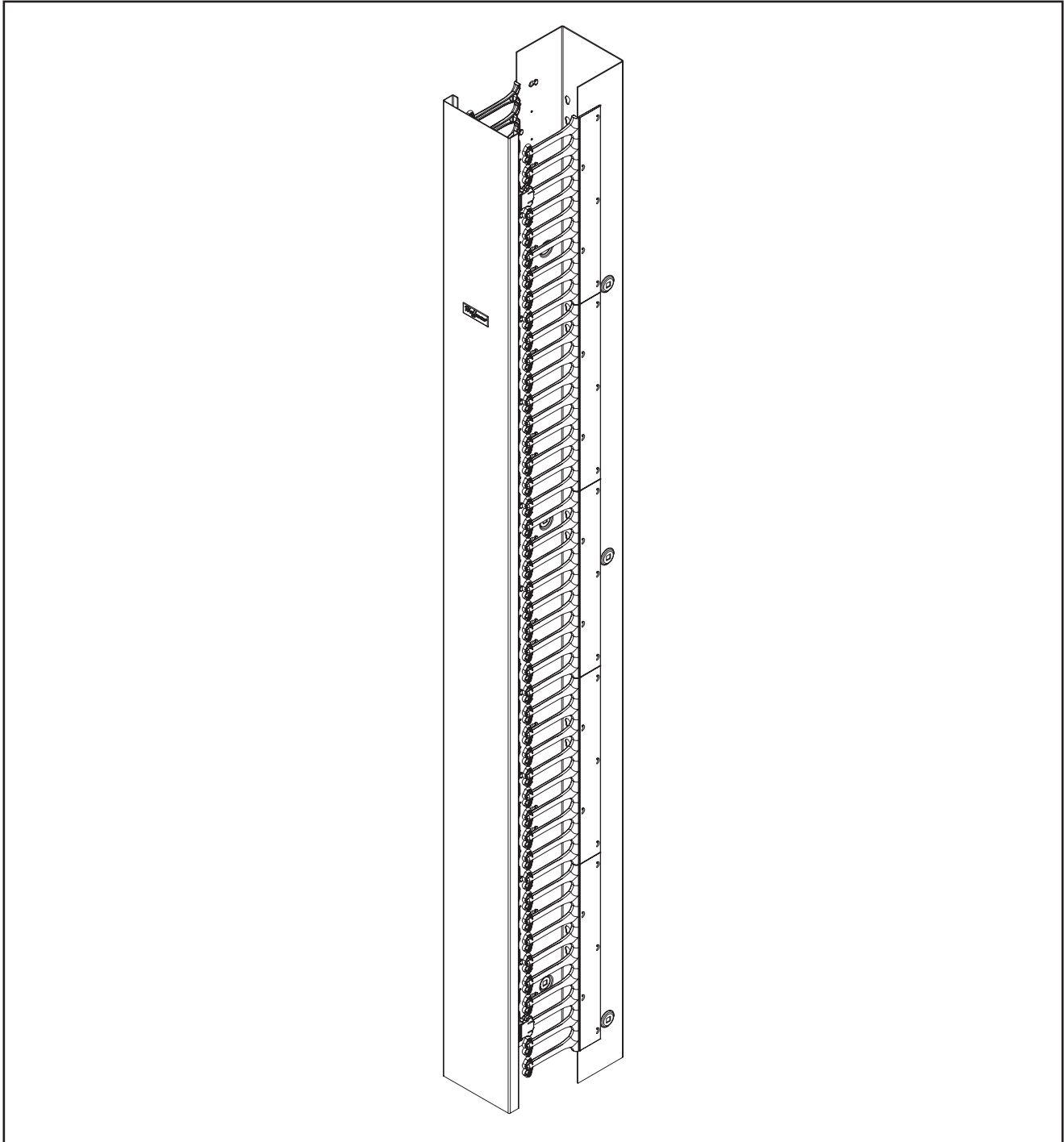

# CABLETEK™-EC

Vertical Cable Manager  
Gestionnaire Vertical De Câble  
Encargado Vertical del Cable

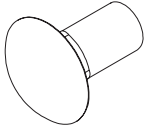

<p>1</p>  <p>(6X)</p>	<p>2</p>  <p>(6X)</p>	<p>3</p>  <p>(2X)</p>	<p>4</p>  <p>(4X)</p>
<p>5</p>  <p>(4X)</p>	<p>6</p>  <p>(1X)</p>	<p>7</p>  <p>(4X)</p>	

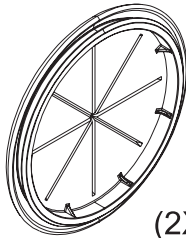
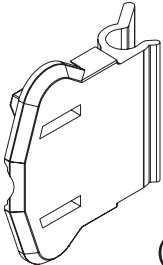
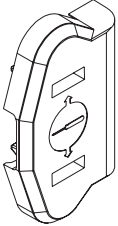
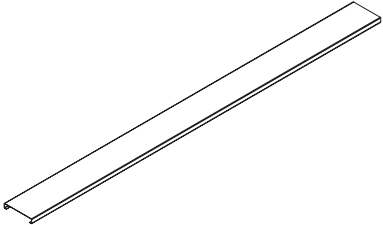
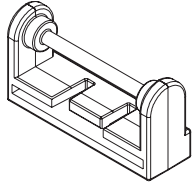
Snap Cover  
Couverture Instantanée  
Cubierta Rápida

Hinged Cover  
Couverture Articulée  
Cubierta con Bisagras

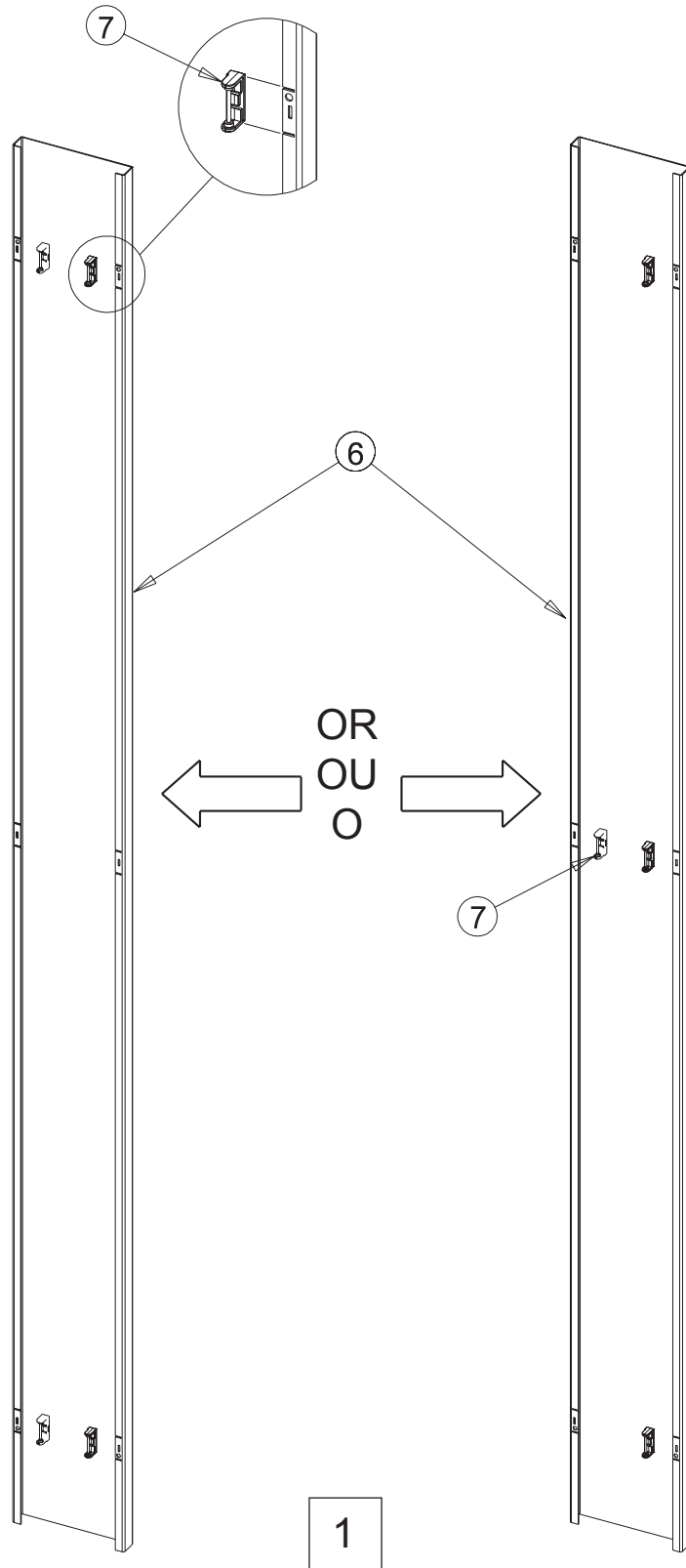

Snap Cover Configuration  
Configuration Instantanée de Couverture  
Configuración Rápida de la Cubierta

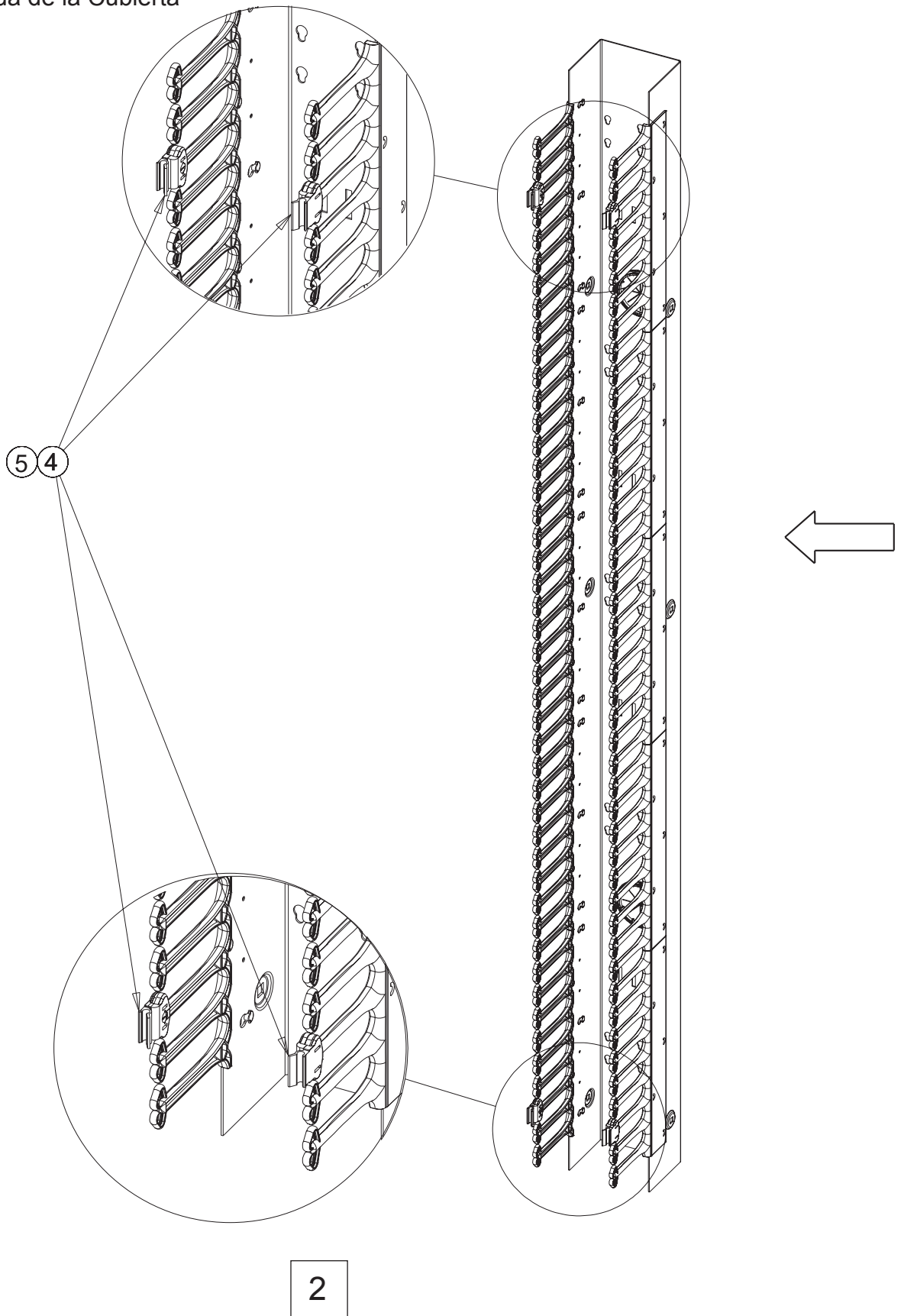

Hinged Cover Configuration  
Configuration Articulée de Couverture  
Configuración con Bisagras de la Cubierta

OR  
OU  
O

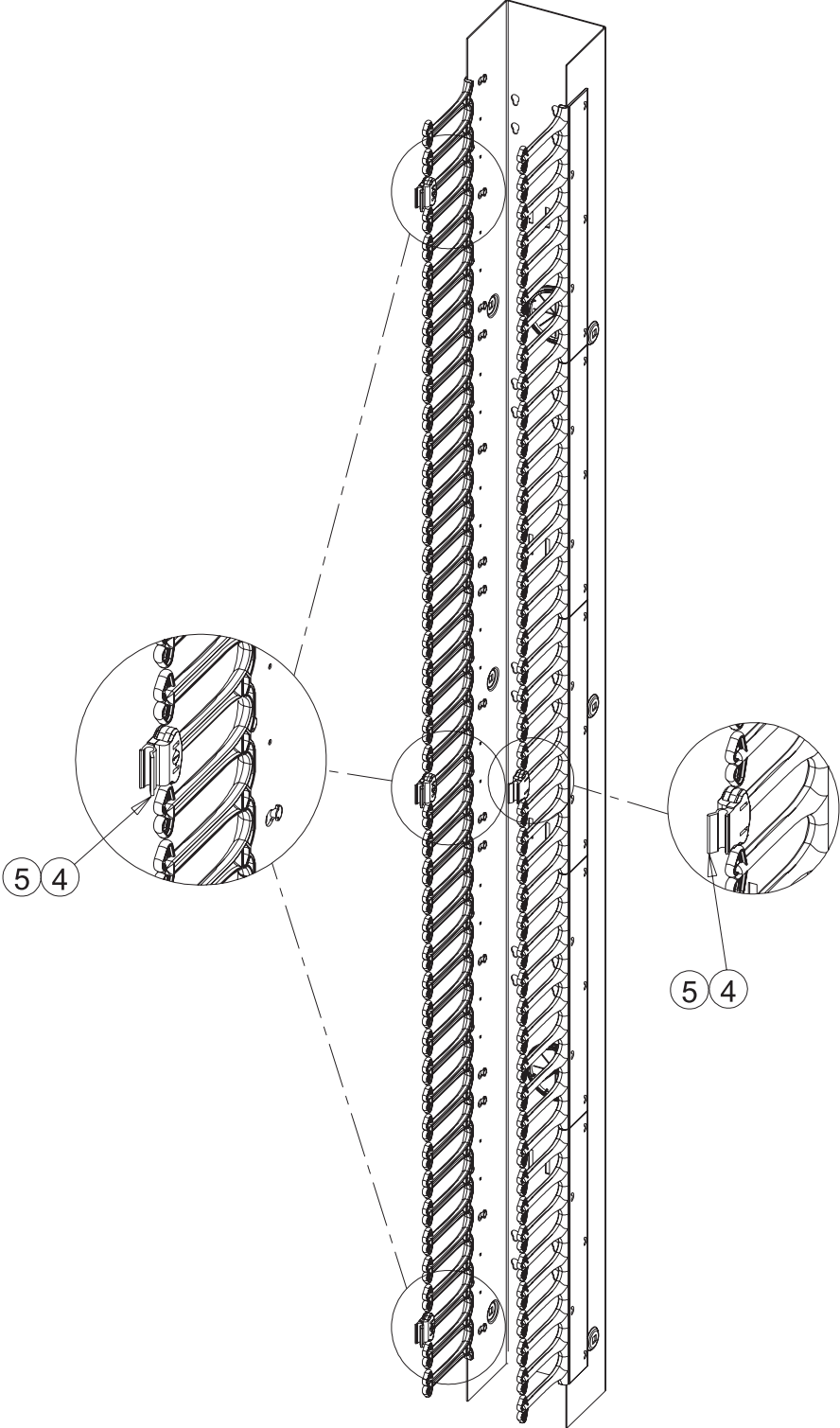

2

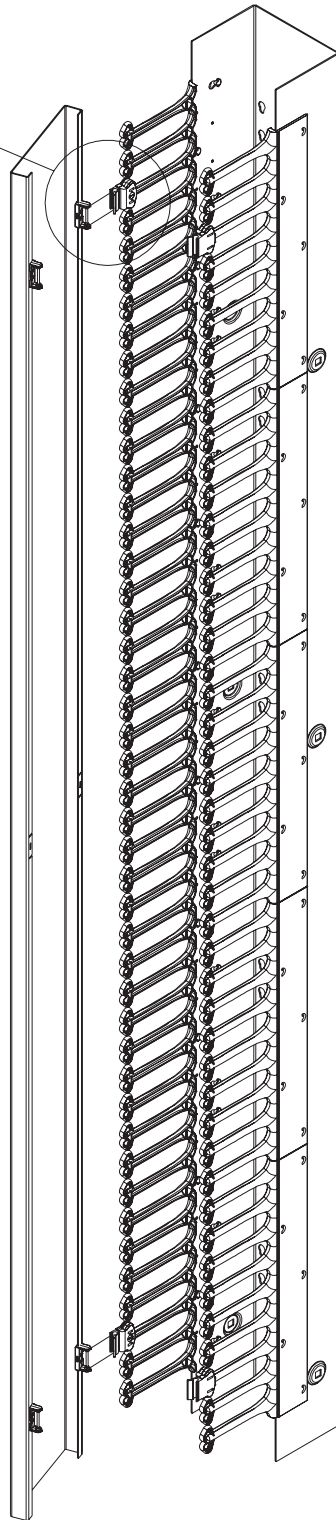
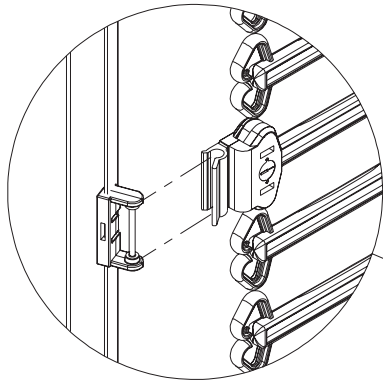

3

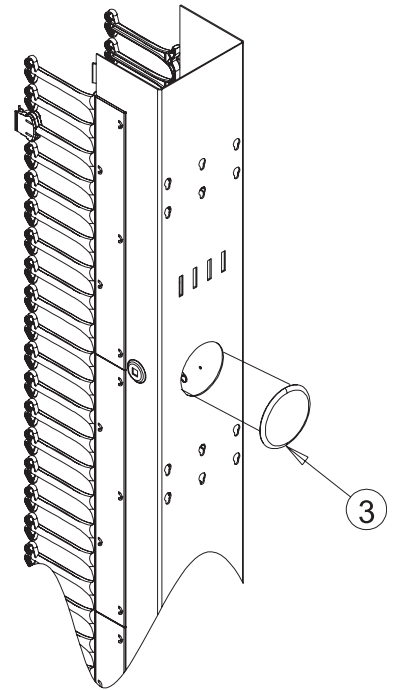

4

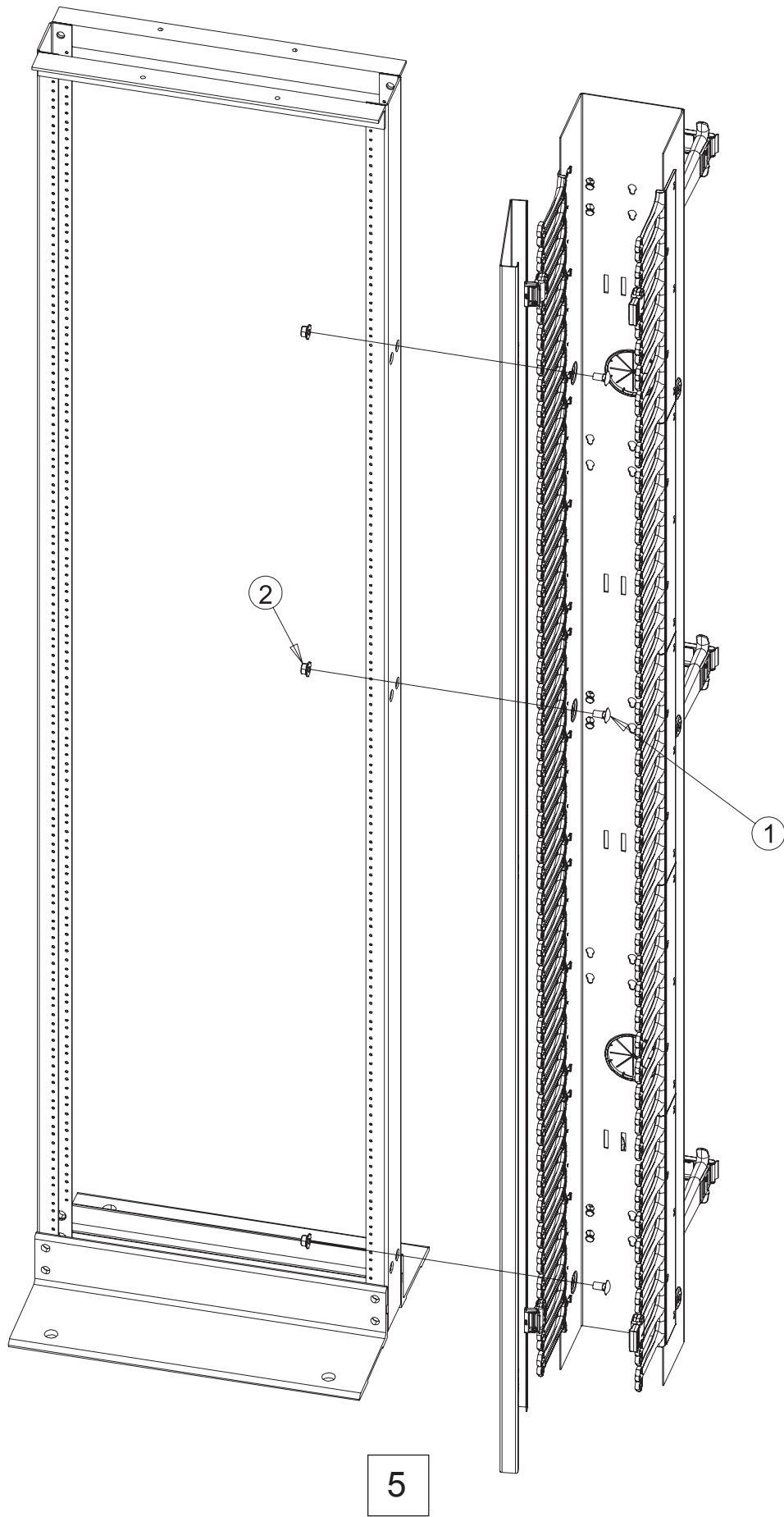

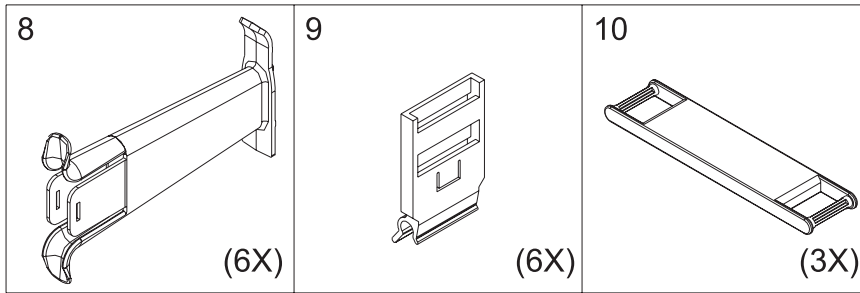

Double-sided models only  
 Modèles double-face uniquement  
 Sólo modelos de dos lados

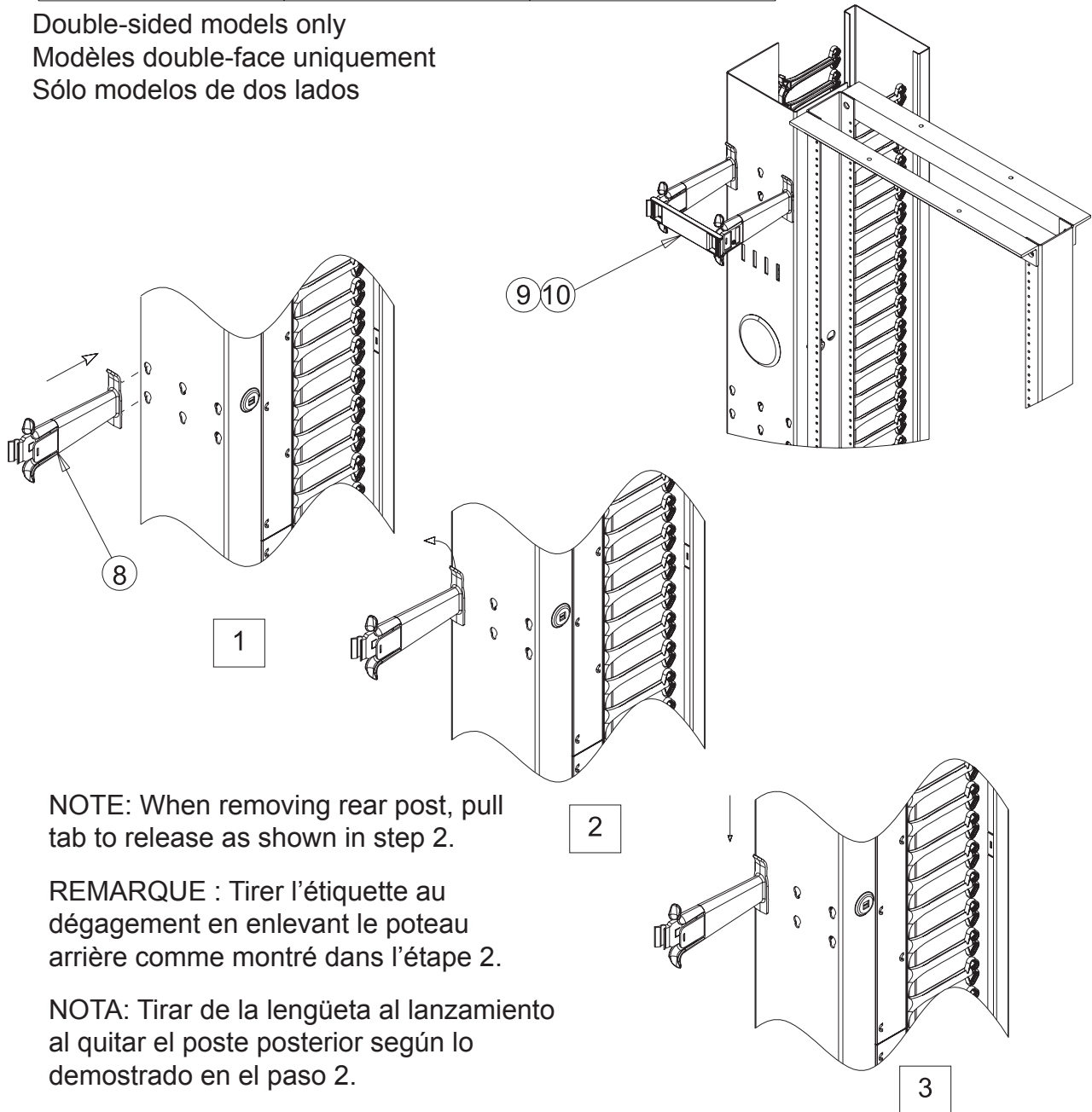

NOTE: When removing rear post, pull tab to release as shown in step 2.

REMARQUE : Tirer l'étiquette au dégagement en enlevant le poteau arrière comme montré dans l'étape 2.

NOTA: Tirar de la lengüeta al lanzamiento al quitar el poste posterior según lo demostrado en el paso 2.

**HOFFMAN (World Headquarters)**  
 2100 Hoffman Way  
 Anoka, MN 55303-1745 USA  
 (763) 421-2240 Fax: (763) 422-2178  
 Customer Service: (763) 422-2211  
 www.hoffmanonline.com

**Canada**  
**HOFFMAN**  
 111 Grangeway Avenue  
 Suite 504  
 Scarborough, Ontario M1H 3E9  
 (416) 289-2770 Fax: (416) 289-2883  
 1-800-668-2500 (Canada only)

**Mexico**  
**HOFFMAN MEXICO, S de RL de CV**  
 Arquímedes No. 33  
 Piso 1  
 Col. Palmas Polanco  
 México, DF  
 CP 11560  
 P: (55) 5280-1596  
 F: (55) 5280-8827 / 5280-8167