

M-3082

2

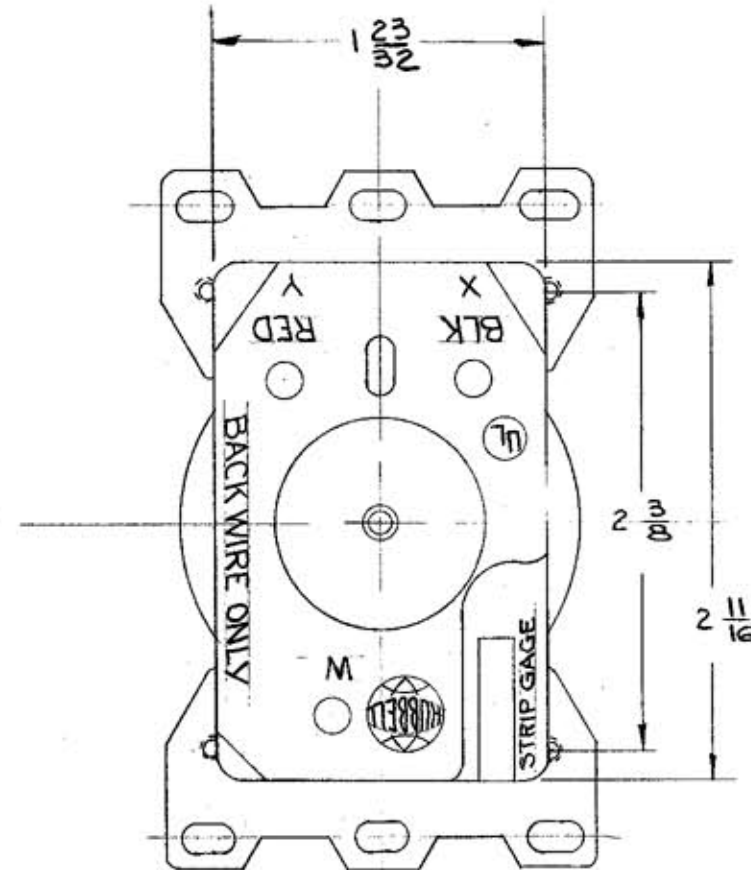
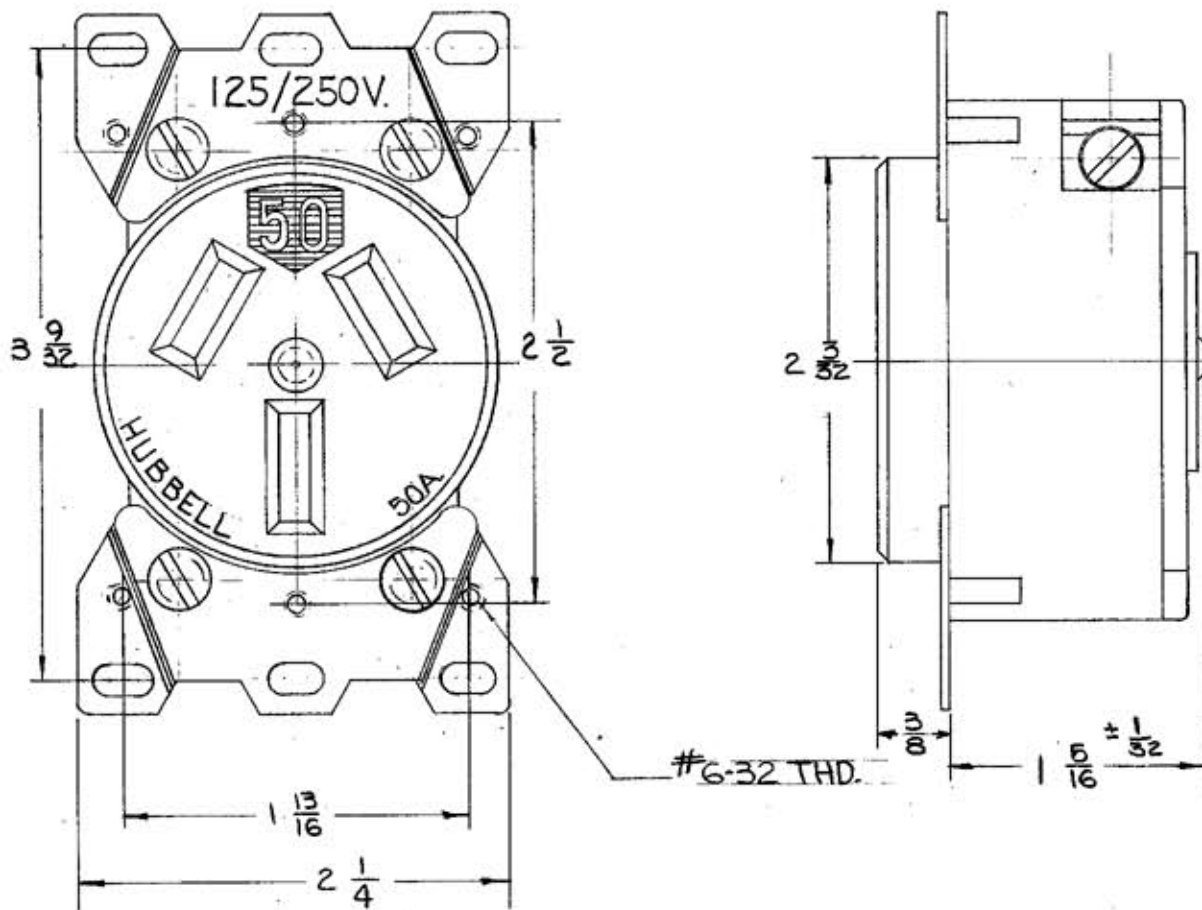

LIST OF PARTS

DESCRIPTION	MATERIAL	FINISH
BODY	BAKELITE	BLACK
MOUNTING PLATE	.040 C.R.S.	ZINC PL.
WIRE CLAMP	.093 C.R.S.	NICKEL PL.
CONTACT SPRINGS	.040 BRASS	NICKEL PL.
AUXILIARY SPRING	.015 STEEL	NICKEL PL.
INSULATOR	.125 DUROID	
BINDING SCREWS	STEEL	CU PL.*

* BINDING SCREW WITH "W" ID. NICKEL PLATE

SYM	REVISIONS	APP	DATE
2	CHANGED WIRE CLAMP, CONT. SPR. AUX. SPR. FINISH FROM CAD TO N. PL. CHANGE BIND. PL. SCR. FINISH FROM CAD TO CU PL.	CS	1-30-91 AJL
1	RATING WAS 50A 250V.	E.P.S. A.S.	11-9-70

SUPERSEDES DWG DATED 3-7-56

TITLE
 50A.125/250V. 3 WIRE SINGLE SHALLOW
 FLUSH TYPE POWER OUTLET WITH PRESS-
 WIRE PLATE BACK WIRING.

TOLERANCES UNLESS
 OTHERWISE SPECIFIED
 FRACTIONS ± 1/64
 DECIMALS ± .005
 ANGLES ± 2°

HARVEY HUBBELL, INC.
 BRIDGEPORT, CONN.
 DR. BY RDT APP. BY
 TR. BY SCALE FULL
 CHK'D. BY ASM DATE 11-17-66