

REV	DATE	DESCRIPTION	ECO	BY	C'H'K.
A	12/11/2008 12:00:00 AM	REDRAW AND CATALOG NUMBER UPDATE	16630	MA	BSK

CATALOG NO.	CONDUCTOR		BOLT SIZE	FIG. NO.	DIMENSIONS								INSTALLATION TOOLING (# CRIMPS)																			
	CODE (AWG)	NAVY ⁵			B ±.08	C ±.04	H REF.	K DIA. ±.02	L ±.12	N ±.04	O.D. ±.01	T REF.	Z MIN.	DIE INDEX	COLOR CODE	MECHANICAL		HYDRAULIC						DIELESS (# CRIMPS)	WIRE STRIP LENGTH							
																MD7-34R MD6	OUR840	BCT500 Y500CT	Y34A ⁶	Y750 Y35, BAT35 Y39, BAT750	Y46 ⁴	Y45 ³	Y48B ⁸			Y60B						
D YAZ29TC38	250 kcmil [120mm ² STR]	250	3/8 [M10]	1	1.62 [41]	1.10 [28]	--		2.98 [76]			.75 [19]	.16 [4]		16	YELLOW	W29VT W29RT (4)	X29RT (6)			A29R (2)	U29RT (2)	U29RT (2)	U29RT (2)	C29R (2)	L29RT (1)	HYDRAULIC Y644, Y644M BAT644M Y644MBH, Y1000 Y1000BH (1)	1-11/16				
YAZ29TC3845					2	2.09 [53]	.40 [10]	2.72 [69]	.41 [10]																							
YAZ29TC3890					3	2.42 [61]		1.32 [34]																								
YAZ29TC12					1	--		3.23 [82]																								
YAZ29TC1245					250 kcmil [120mm ² STR]	250	1/2 [M12]	2	2.09 [53]		2.09 [53]	.52 [13]	2.97 [75]	.53 [13]																		
YAZ29TC1290									3	1.62 [41]	1.10 [28]	2.42 [61]		1.58 [40]		.75 [19]	.16 [4]															

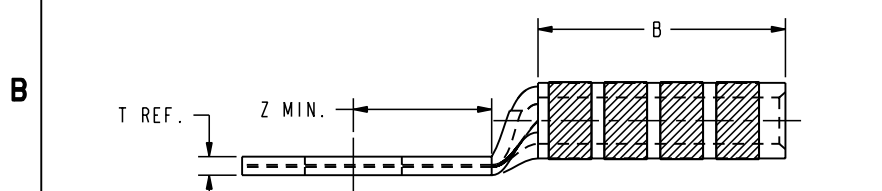
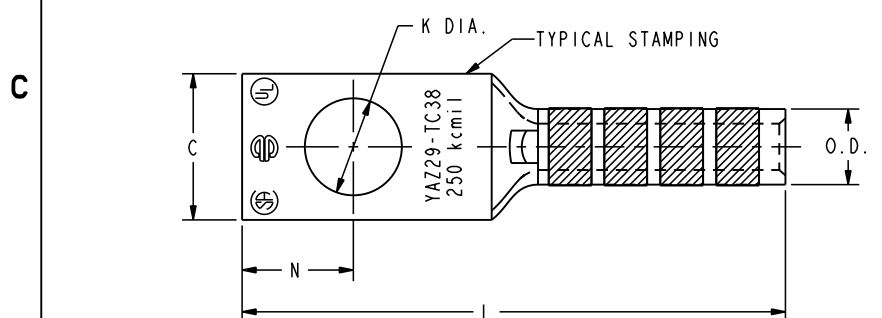

FIG. 1

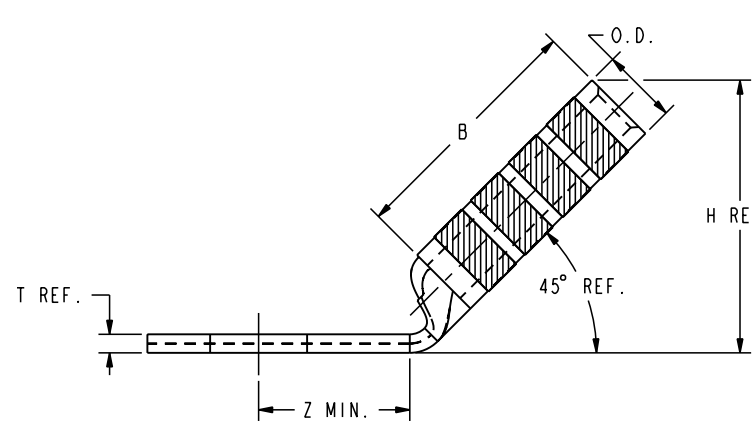
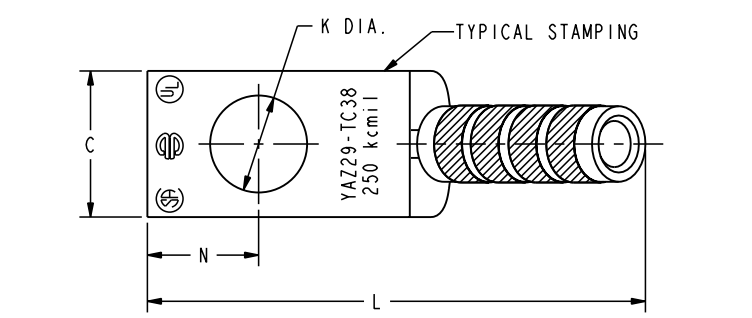

FIG. 2

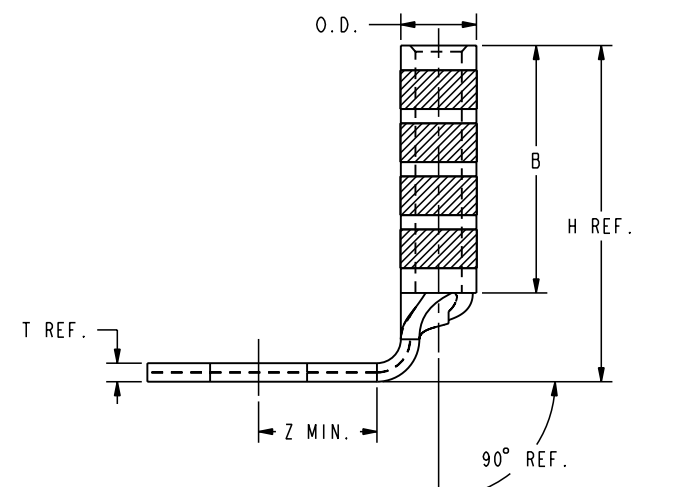
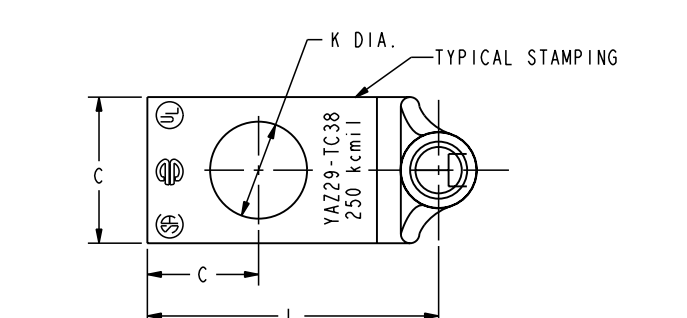

FIG. 3

- NOTES:
1. MATERIAL: COPPER TUBING.
 2. FINISH: TIN PLATED
 3. CATALOG # PT6515 ADAPTOR IS REQUIRED TO USE "U" DIES IN Y45 SERIES TOOLS.
 4. CATALOG # PUADP-1 ADAPTOR IS REQUIRED TO USE "U" DIES IN Y46 SERIES TOOLS.
 5. NAVY CABLE SIZE MAY BE OMITTED ON SOME SIZES BECAUSE OF SPACE LIMITATIONS.
 6. FOR USE BY CUSTOMERS THAT HAVE THIS HYPRESS™. NO NEW Y34A HYPRESS™ TOOLS ARE BEING PROCESSED.
 7. DIMENSIONS, METRIC WIRE, & METRIC BOLT SIZES IN BRACKETS [] ARE IN MILLIMETERS. DIMENSIONS ARE ROUNDED OFF TO THE NEAREST MILLIMETER, UNLESS OTHERWISE NOTED, AND ARE FOR REFERENCE ONLY.
 8. OVERLAPPING CRIMPS ARE REQUIRED ON THESE SIZES.

TO ORDER BURNDY® PRODUCTS CALL		HYLUG™ (ONE HOLE CODE)	
UNITED STATES 1-800-346-4175 (LONDONDERRY, NH)		ITEM NO: NA	CAT. NO: YAZ29-TC- (TABLE)
CANADA: 1-800-361-6975 (QUEBEC) 1-800-387-6487 (ALL OTHER PROVINCES)		DRAWN BY: D.BOISVERT 02/03/2000	CHECKER: R.BOISVERT 01/10/2001
FOR PRODUCT INFO: http://www.burndy.com		DSN APPVL: J.MICHAUD 05/04/2000	MFG APPVL: N/A
		QA APPVL: S.BROWN	MKT APPVL: N/A
		PROD FAM: --	SCALE: NTS
		PROJECT #: --	SIZE: D
		DOCUMENT TYPE: Sales	DRAWING NO: SE212356
		REL LEVEL: Released	SHEET 21 OF 40

REV: PE0200