

M-11913 1

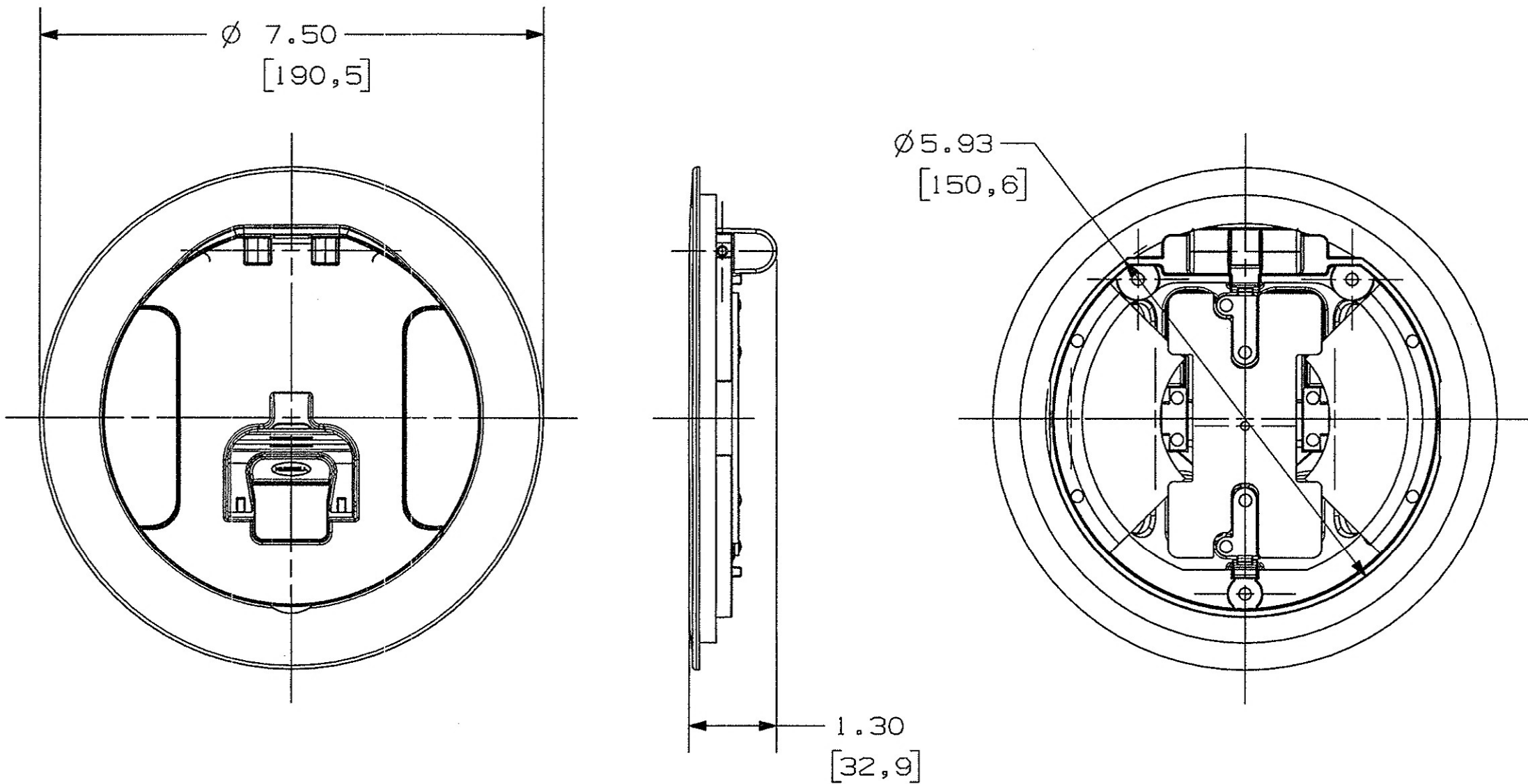

CATALOG NUMBER	FINISH
S1R6CVRBLK	BLACK POWDER COAT PAINT
S1R6CVRNKL	SATIN NICKEL PLATE
S1R6CVRALU	BRUSHED ALUMINUM
S1R6CVRBRZ	BRONZE PLATED
S1R6CVRBRS	BRASS PLATED

NOTES:
 1) ALL DIMENSIONS ARE IN INCHES AND [MILLIMETERS]
 2) SUPPLIED WITH (3) MOUNTING SCREWS (NOT SHOWN).

LIST OF PARTS

DESCRIPTION	MATERIAL	FINISH
FLANGE RING	ALUMINUM	SEE TABLE
MAIN DOOR	ALUMINUM	SEE TABLE
ACCESS DOORS	ALUMINUM	SEE TABLE
HANDLE	ALUMINUM	SEE TABLE
HANDLE BEARING BLOCK	ALUMINUM	SEE TABLE
LINKS	ALUMINUM	SEE TABLE
SLIDERS	ALUMINUM	SEE TABLE
DOOR GASKETS	FOAM RUBBER	BLACK
MOUNTING SCREWS	STEEL	ZINC PLATE
DRIVE SCREWS	STEEL	ZINC PLATE
FIRE BARRIER	FIRE BAR. MATL.	NATURAL
SPRINGS	STEEL	ZINC PLATE
DOWEL PINS	STEEL	ZINC PLATE
SLIDER RETAINERS	STEEL	ZINC PLATE
RATCHET PLATES	STEEL	ZINC PLATE
RETAINER PLATES	STEEL	ZINC PLATE
WEATHERSTRIP	ALUM./NYLON	PLAIN/BLACK
CAP SCREWS	STEEL	ZINC PLATE
FIRE BARRIER COVER	STEEL	ZINC PLATE

DIMENSION SHEET FOR CAT. NO. SEE TABLE

REPAIRABLE NON-REPAIRABLE

B

M-11913

1

1	RELEASED PER DCN18435	12/14/11
SYM	REVISIONS	APP DATE

THE DESIGN AND DIMENSIONS OF THE PRODUCT SHOWN ON THIS DRAWING ARE SUBJECT TO CHANGE WITHOUT NOTICE

TITLE COVER, FIRE RATED POKE THROUGH, 6 INCH DIAMETER

TOLERANCES UNLESS OTHERWISE SPECIFIED FRACTIONS ± 1/64 DECIMALS ± .005 ANGLES ± 2°	WIRING DEVICE-KELLEMS HUBBELL INCORPORATED BRIDGEPORT, CT	
	DR. BY SRE	APP. BY <i>[Signature]</i>
	TR. BY	SCALE 1:2
	CHK'D BY <i>[Signature]</i>	DATE 6/7/11

NOTES:
UNLESS OTHERWISE SPECIFIED,
1) ALL DIMENSIONS ARE IN INCHES AND [MILLIMETERS]

M-12043 3

.92
[23,4]

(3) SOLID WIRES - #12 AWG
RECEPTACLES WIRED IN SERIES

DIMENSION A

.26
[6,5]

20A 125V
PER NEMA 5-20R

5.25
[133,3]

2.48
[62,9]

SIR6SPZ SHOWN

BLACK

GREEN

WHITE

LIST OF PARTS

DESCRIPTION	MATERIAL	FINISH
COVER PLATE	STEEL	WHITE
RECEPTACLES	----	BLACK
SOLID WIRE	COPPER	SEE DWG.
MOUNTING SCREWS	STEEL	WHITE

DIMENSION SHEET FOR CAT. NO. SEE CHART

REPAIRABLE NON-REPAIRABLE

B M-12043

3

SYM	REVISIONS	APP	DATE
3	ADDED RECEPTACLE MARKING COLUMN TO TABLE, ADDED BASE CAT. NUMBER SHOWN PER DCN 21844. MYA	DJP	3/16/16
2	IN TITLE 40% WAS 60% DCN18952 SRE	SM	7/16/12
1	RELEASED PER DCN18435		1/4/12

THE DESIGN AND DIMENSIONS OF THE PRODUCT SHOWN ON THIS DRAWING ARE SUBJECT TO CHANGE WITHOUT NOTICE

TITLE POWER PLATE, RIGHT, 40%, 6 INCH FRPT

TOLERANCES UNLESS OTHERWISE SPECIFIED .XX = ±.01 .XXX = ±.005 ANGLES = ±2°	WIRING DEVICE-KELLEMS HUBBELL INCORPORATED SHELTON, CT	
	DR. BY SRE	APP. BY SM
	TR. BY	SCALE 1:2
	CHK. BY SM	DATE 1/4/12

CATALOG NO.	DIMENSION A	RECEPTACLE MARKING
SIR6SPZ	18.0 [457,2]	-
SIR6SPZ25	25 FEET, 762 CM	-
SIR6SPZC	18.0 [457,2]	CONTROLLED

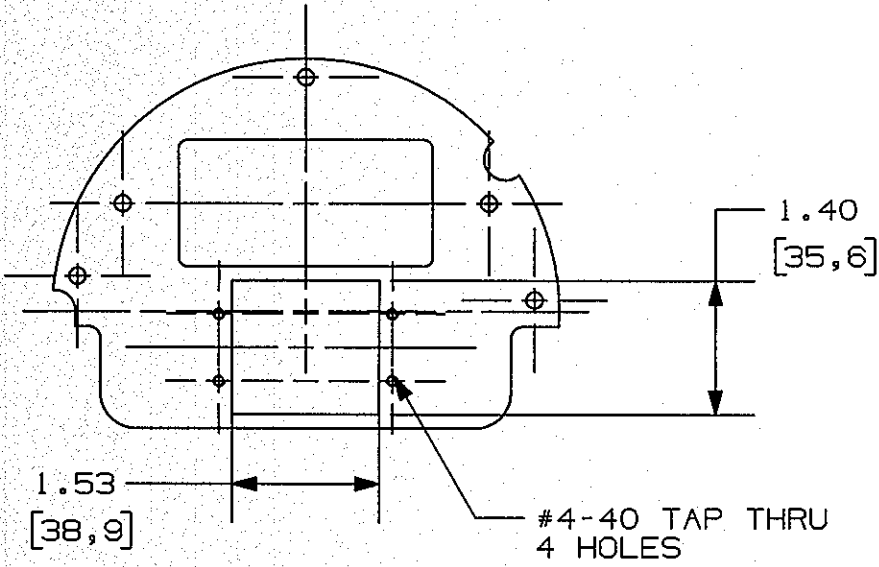

CATALOG NUMBER SIR6SPV

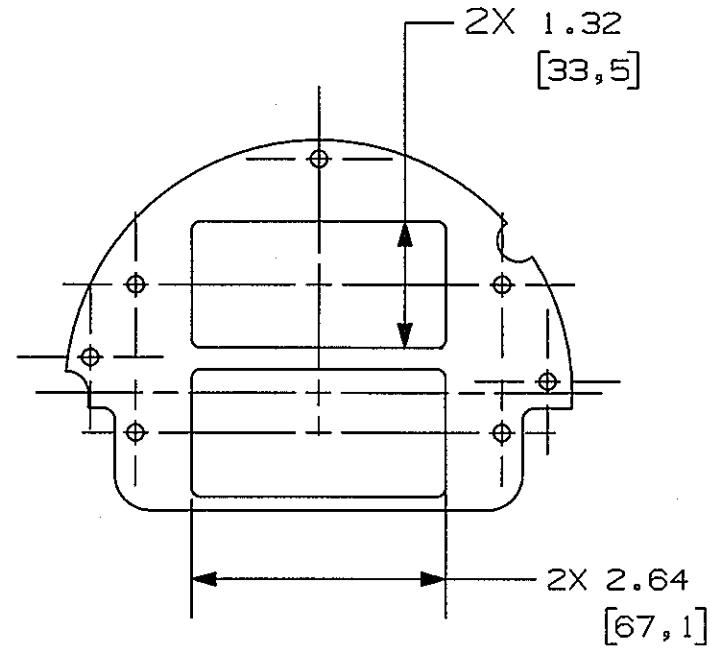

CATALOG NUMBER SIR6SPW

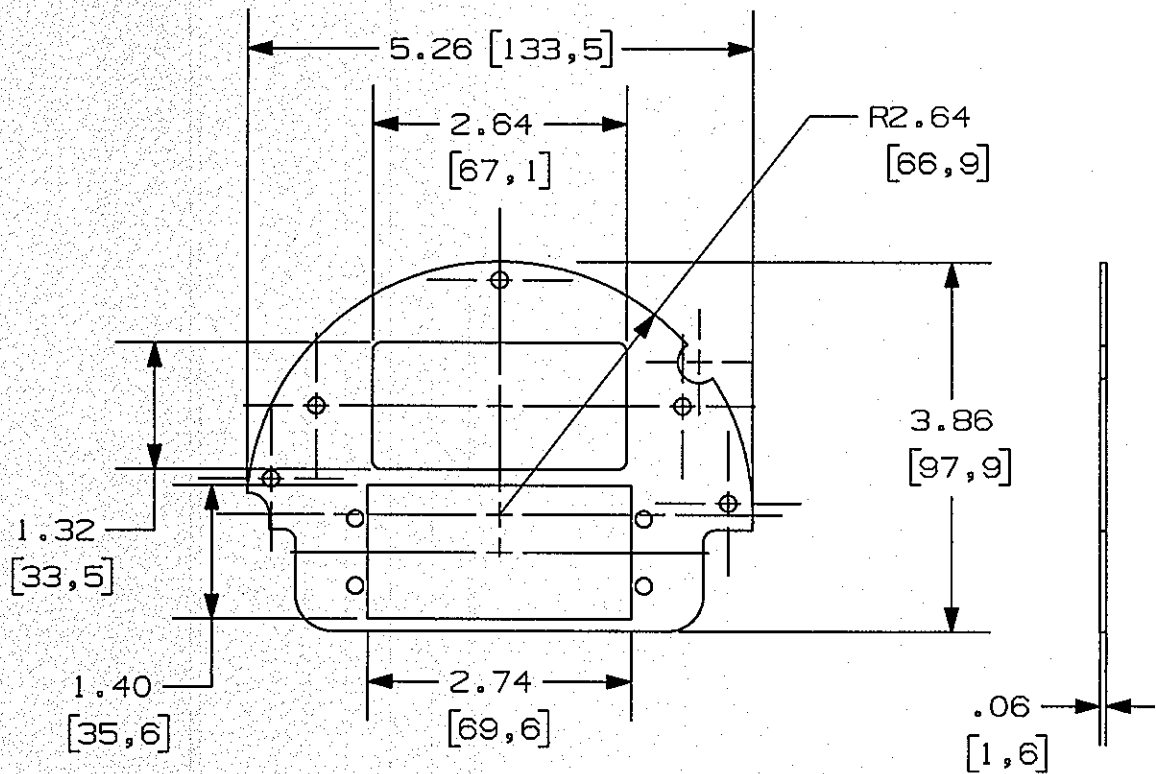

CATALOG NUMBER SIR6SPX

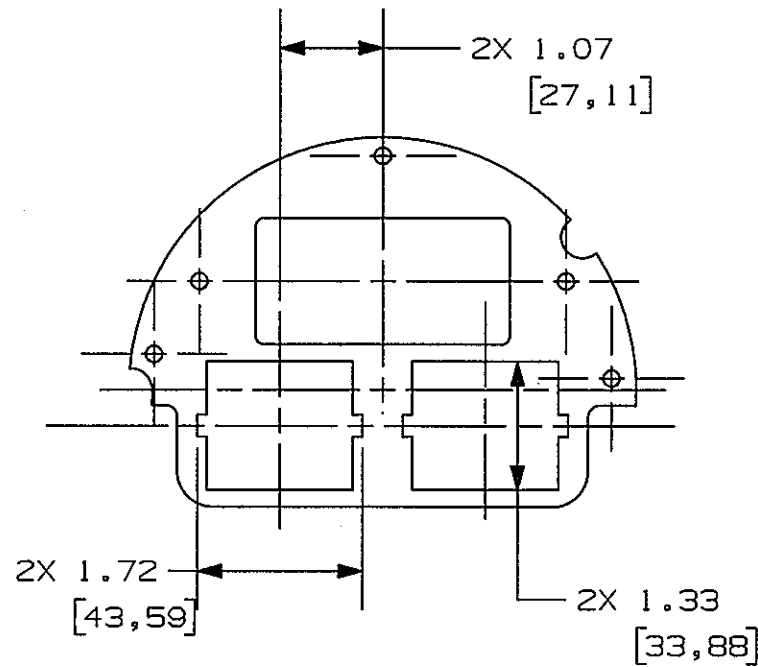

CATALOG NUMBER SIR6SPY

LIST OF PARTS

DESCRIPTION	MATERIAL	FINISH
COVER PLATE	STEEL	ZINC
MOUNTING SCREWS	STEEL	ZINC

SHEET 1 OF 2

DIMENSION SHEET FOR CAT. NO. M-11915
 SEE INDIVIDUAL CAT. NOS. REPAIRABLE NON-REPAIRABLE

2	IN NOTE 2, SEE SIR6SPX WAS SEE SIR6SPV. ADDED SHEET 2. PER DCN 20908 DDL	DJP	12/02/14
1	RELEASED PER DCN		6/15/11
SYM	REVISIONS	APP	DATE

THE DESIGN AND DIMENSIONS OF THE PRODUCT SHOWN ON THIS DRAWING ARE SUBJECT TO CHANGE WITHOUT NOTICE

TITLE
 COVER PLATES, 60/40, LH, FIRE RATED POKE THROUGH, 6 INCH DIAMETER

TOLERANCES UNLESS OTHERWISE SPECIFIED .XX = ±.01 .XXX = ±.005 ANGLES = ±2°	WIRING DEVICE-KELLEMS HUBBELL INCORPORATED SHELTON, CT	
	DR. BY SRE	APP. BY
	TR. BY	SCALE 1:2
	CHK. BY	DATE 6/15/11

- NOTES:
 1) ALL DIMENSIONS ARE IN INCHES AND [MILLIMETERS]
 2) ALL PLATES HAVE THE SAME OVERALL OUTSIDE DIMENSIONS AND THICKNESS. SEE SIR6SPX.
 3) ALL PLATES SHIPPED WITH MOUNTING SCREWS, NOT SHOWN.

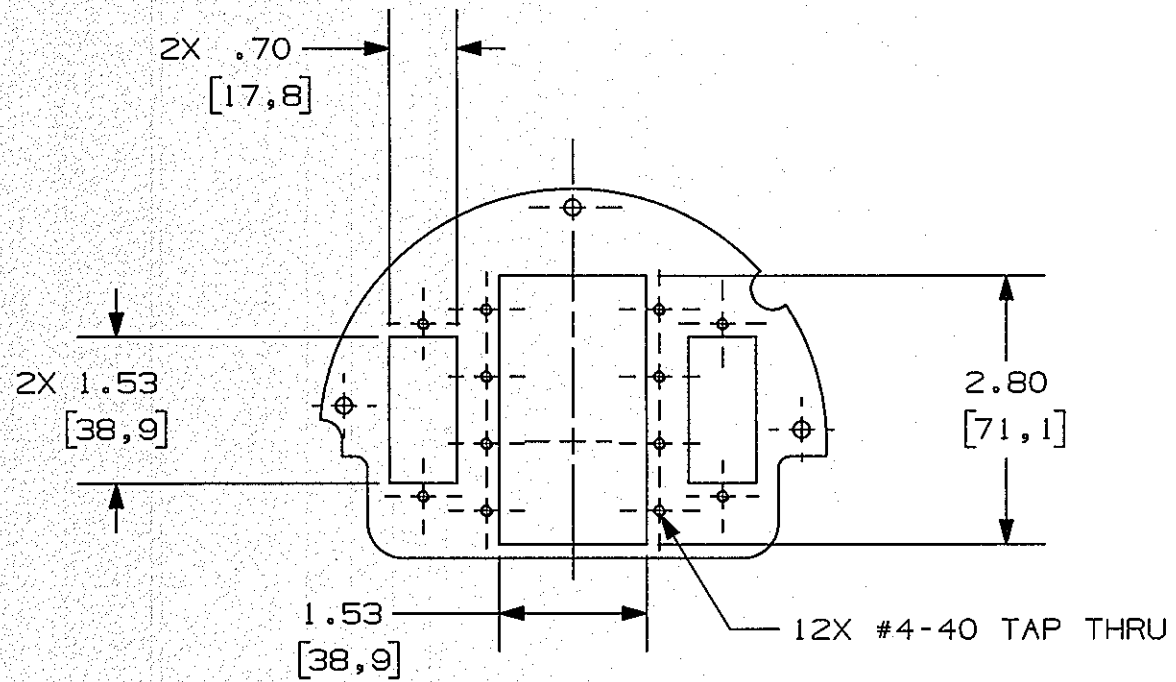

CATALOG NUMBER S1R6SPT

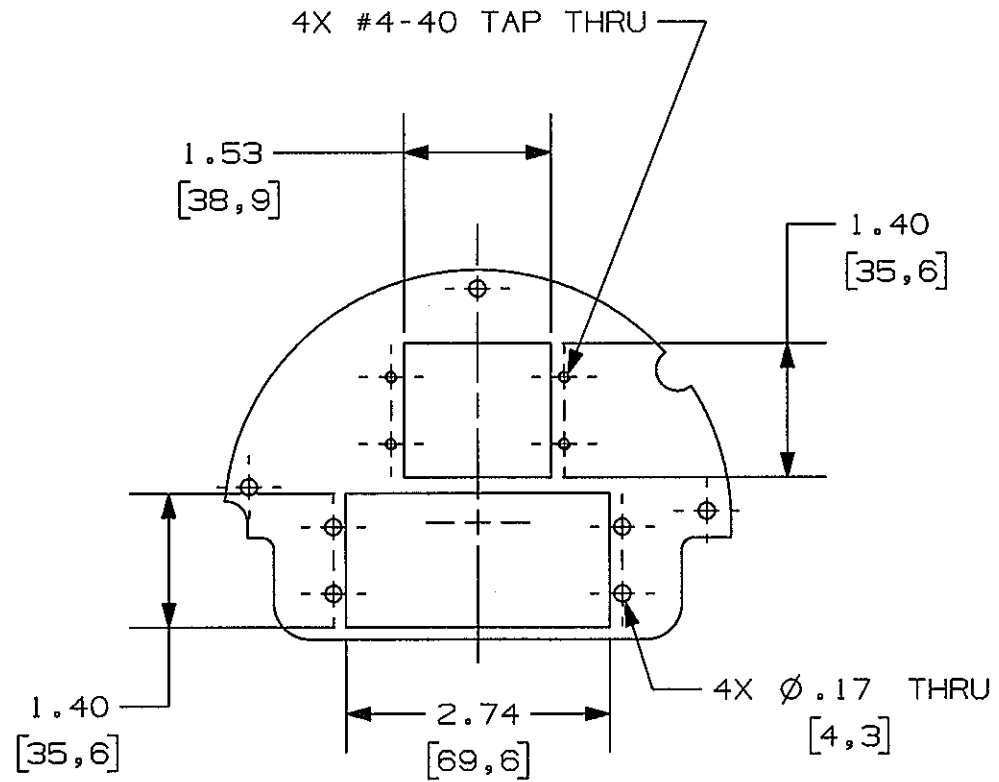

CATALOG NUMBER S1R6SPU

LIST OF PARTS

DESCRIPTION	MATERIAL	FINISH
COVER PLATE	STEEL	ZINC
MOUNTING SCREWS	STEEL	ZINC

SHEET 2 OF 2

2	ADDED SHEET 2. PER DCN 20908 DDL	DJP	12/02/14
SYM	REVISIONS	APP	DATE

THE DESIGN AND DIMENSIONS OF THE PRODUCT SHOWN ON THIS DRAWING ARE SUBJECT TO CHANGE WITHOUT NOTICE

TITLE
COVER PLATES, 60/40, LH, FIRE RATED POKE THROUGH, 6 INCH DIAMETER

TOLERANCES UNLESS OTHERWISE SPECIFIED .XX = ±.01 .XXX = ±.005 ANGLES = ±2°	WIRING DEVICE-KELLEMS HUBBELL INCORPORATED SHELTON, CT	
	DR. BY SRE	APP. BY
	TR. BY	SCALE 1:2
	CHK. BY	DATE 6/15/11

DIMENSION SHEET FOR CAT. NO.

SEE INDIVIDUAL CAT. NOS. REPAIRABLE NON-REPAIRABLE

B

M-11915

2

M-11920 5

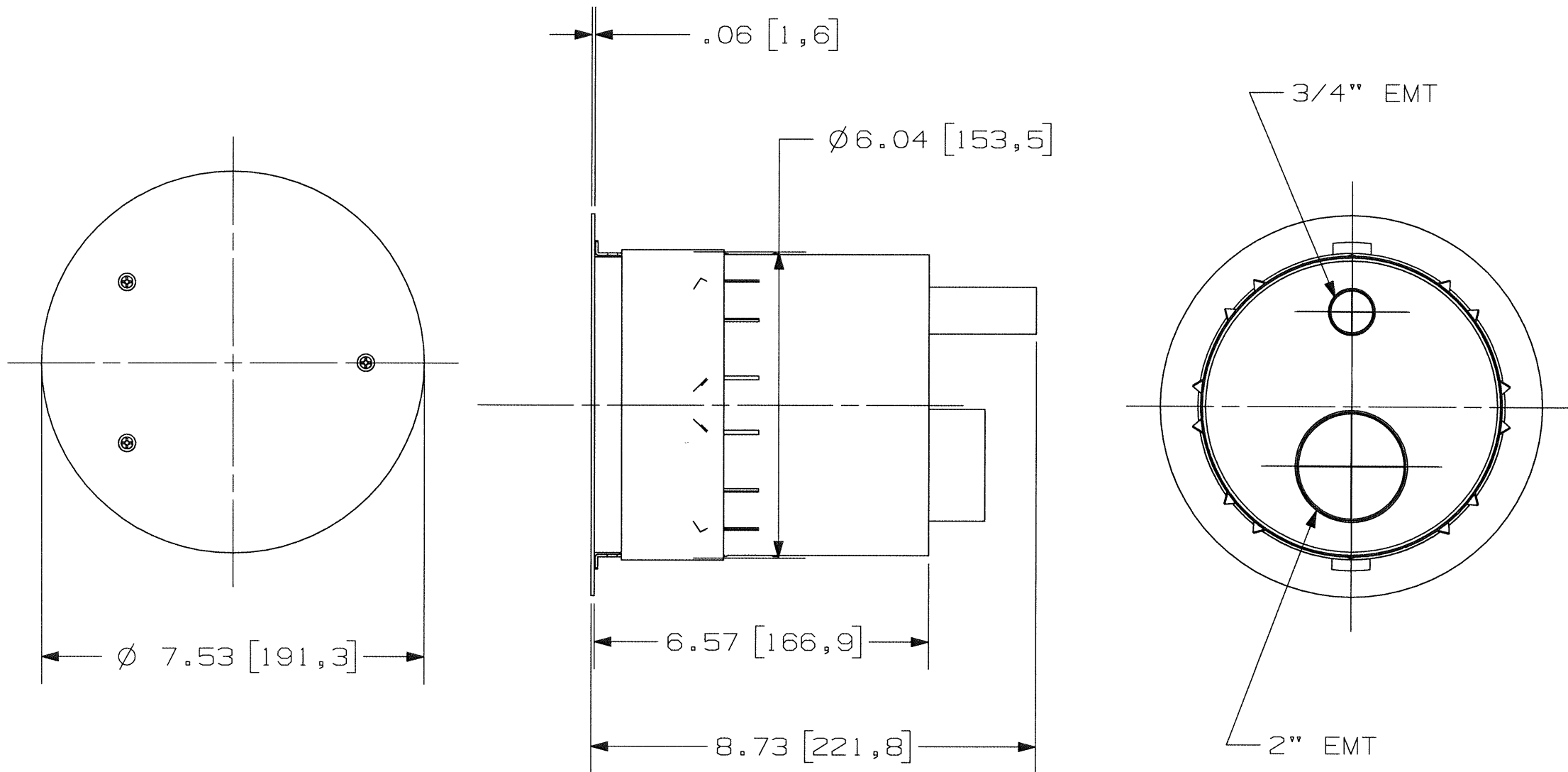

NOTES:
 1) ALL DIMENSIONS ARE IN INCHES AND [MILLIMETERS]
 2) JUNCTION BOX S1FRPTJB (NOT SHOWN) IS INCLUDED WITH FLOOR FITTING CATALOG NUMBER S1R6PTFIT. SEE DWG. M-11000 FOR DIMENSIONS OF JUNCTION BOX. JUNCTION BOX SHIPPED LOOSELY WITH UNIT.

LIST OF PARTS

DESCRIPTION	MATERIAL	FINISH
CAN WELDMENT	STEEL	ZINC PLATE
INSTALLATION PLATE	STEEL	ZINC PLATE
SUB-PLATE MTG. PLATE	STEEL	WHITE PAINT
STANDOFFS	STNLS. STEEL	--
FIRE BARRIER, UPPER	FIRE BAR. MATL.	NATURAL
FIRE BARRIER, LOWER	FIRE BAR. MATL.	NATURAL
DIVIDER	STEEL	ZINC PLATE
WASHERS	FIBER	RED
MOUNTING SCREWS	STEEL	ZINC PLATE
SPACER	FIRE BAR. MATL.	BLACK
TAPE	PLASTIC	YELL./BLK

NO.	DESCRIPTION	APP.	DATE
5	ADDED SHEET 2 PER DCN23387	AD	10/18/17
4	IN PARTS LIST- FOR STANDOFF "FINISH" -- WAS ZINC PLATE PER DCN 21112. MYA	PJB	4/8/15
3	UPDATED IMAGES PER DCN20245		12/13/13
2	UPDATED IMAGES, 8.73 WAS 8.71 6.48 WAS 6.45 DCN18755		4/13/12
1	RELEASED PER DCN18435		12/14/11

SYM	REVISIONS	APP	DATE

THE DESIGN AND DIMENSIONS OF THE PRODUCT SHOWN ON THIS DRAWING ARE SUBJECT TO CHANGE WITHOUT NOTICE

TITLE
 SERVICE FITTING,
 FIRE RATED POKE THROUGH,
 6 INCH DIAMETER

TOLERANCES UNLESS OTHERWISE SPECIFIED .XX = ± .01 .XXX = ± .005 ANGLES = ± 2°	WIRING DEVICE-KELLEMS HUBBELL INCORPORATED SHELTON, CT	
	DR. BY SRE	APP. BY
	TR. BY	SCALE 1:2
	CHK. BY	DATE 6/9/11

DIMENSION SHEET FOR CAT. NO. S1R6PTFIT

REPAIRABLE NON-REPAIRABLE

B

M-11920

5

M-11920 5

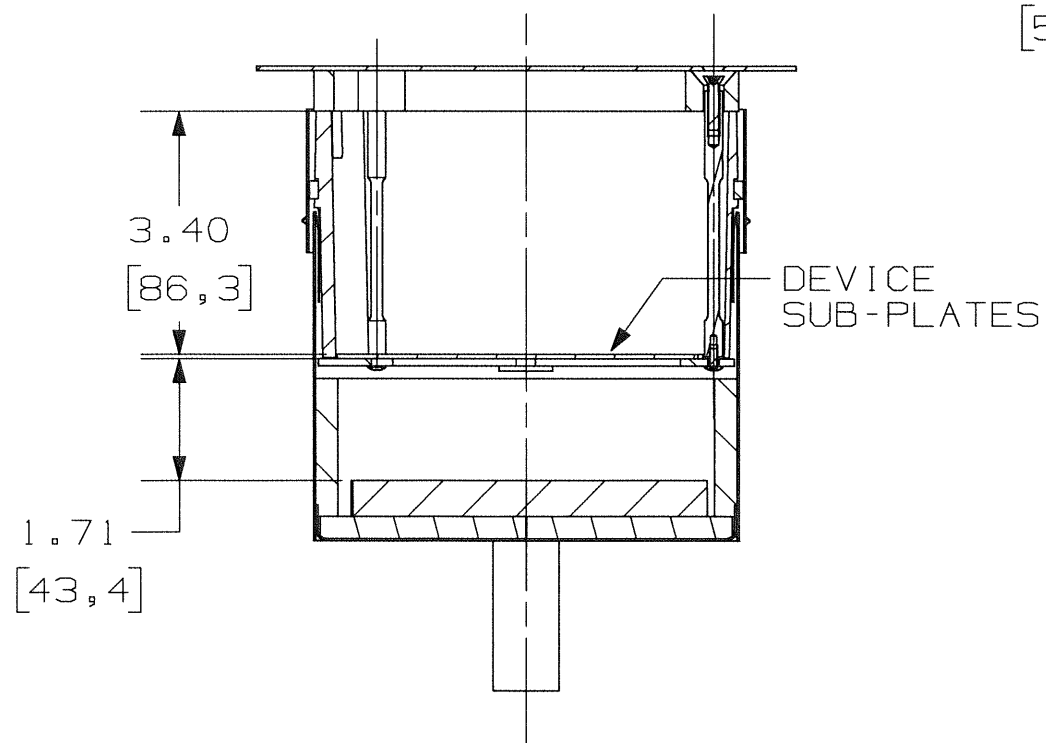
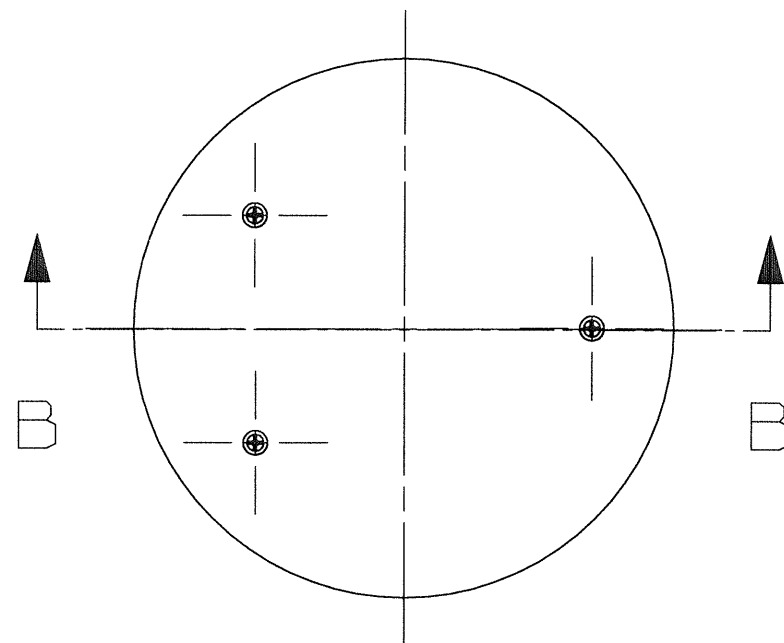
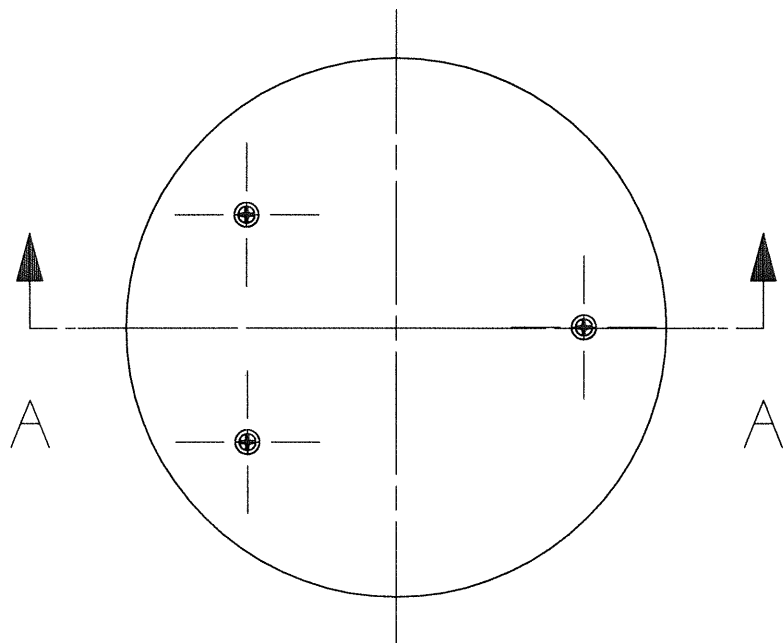

SECTION A-A

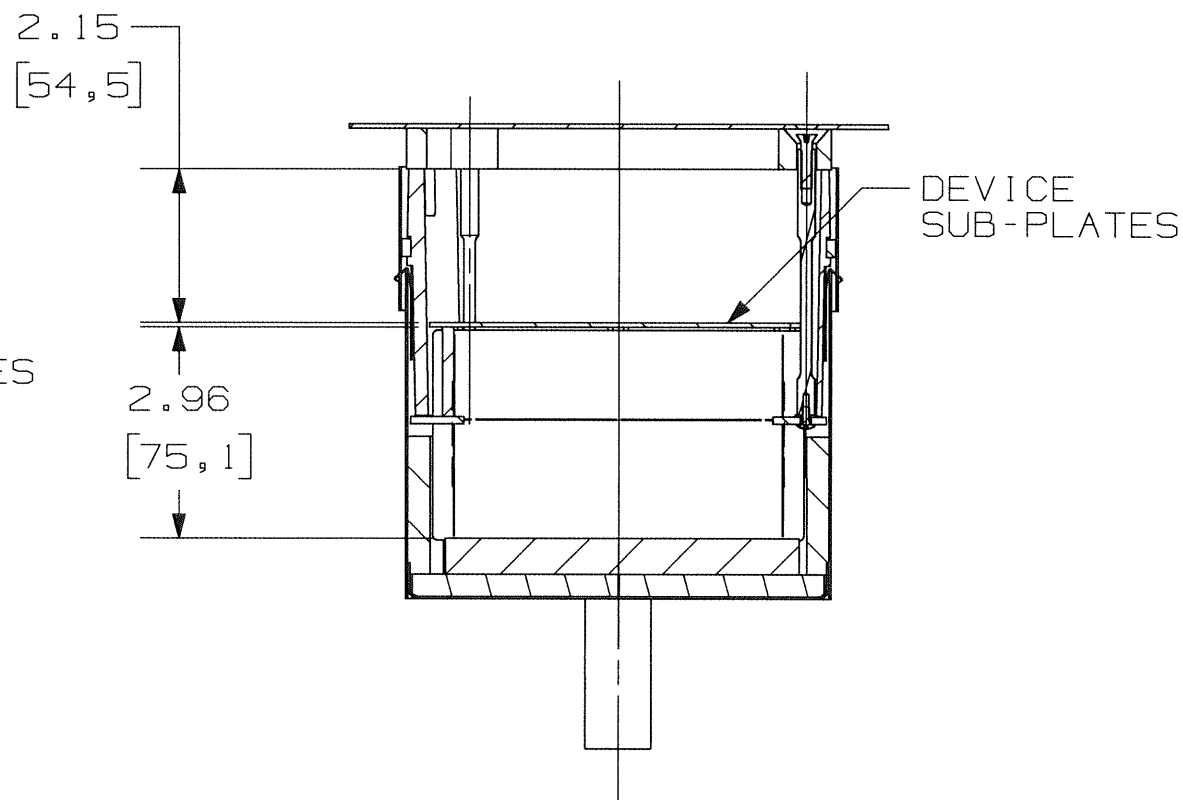

SECTION B-B

INCLUDES SIR6SPEXT EXTENSION KIT

LIST OF PARTS		
DESCRIPTION	MATERIAL	FINISH

5	ADDED THIS SHEET PER DCN23387	AD	10/18/17
SYM	REVISIONS	APP	DATE

THE DESIGN AND DIMENSIONS OF THE PRODUCT SHOWN ON THIS DRAWING ARE SUBJECT TO CHANGE WITHOUT NOTICE

TITLE
SERVICE FITTING,
FIRE RATED POKE THROUGH,
6 INCH DIAMETER

TOLERANCES UNLESS OTHERWISE SPECIFIED .XX = ±.01 .XXX = ±.005 ANGLES = ±2°	WIRING DEVICE-KELLEMS HUBBELL INCORPORATED SHELTON, CT	
	DR. BY AD	APP. BY
	TR. BY	SCALE 1:2
	CHK. BY	DATE 6/9/11

DIMENSION SHEET FOR CAT. NO. SIR6PTFIT
 REPAIRABLE NON-REPAIRABLE B M-11920 5

M-11000 2

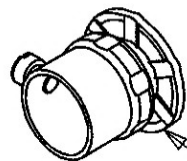
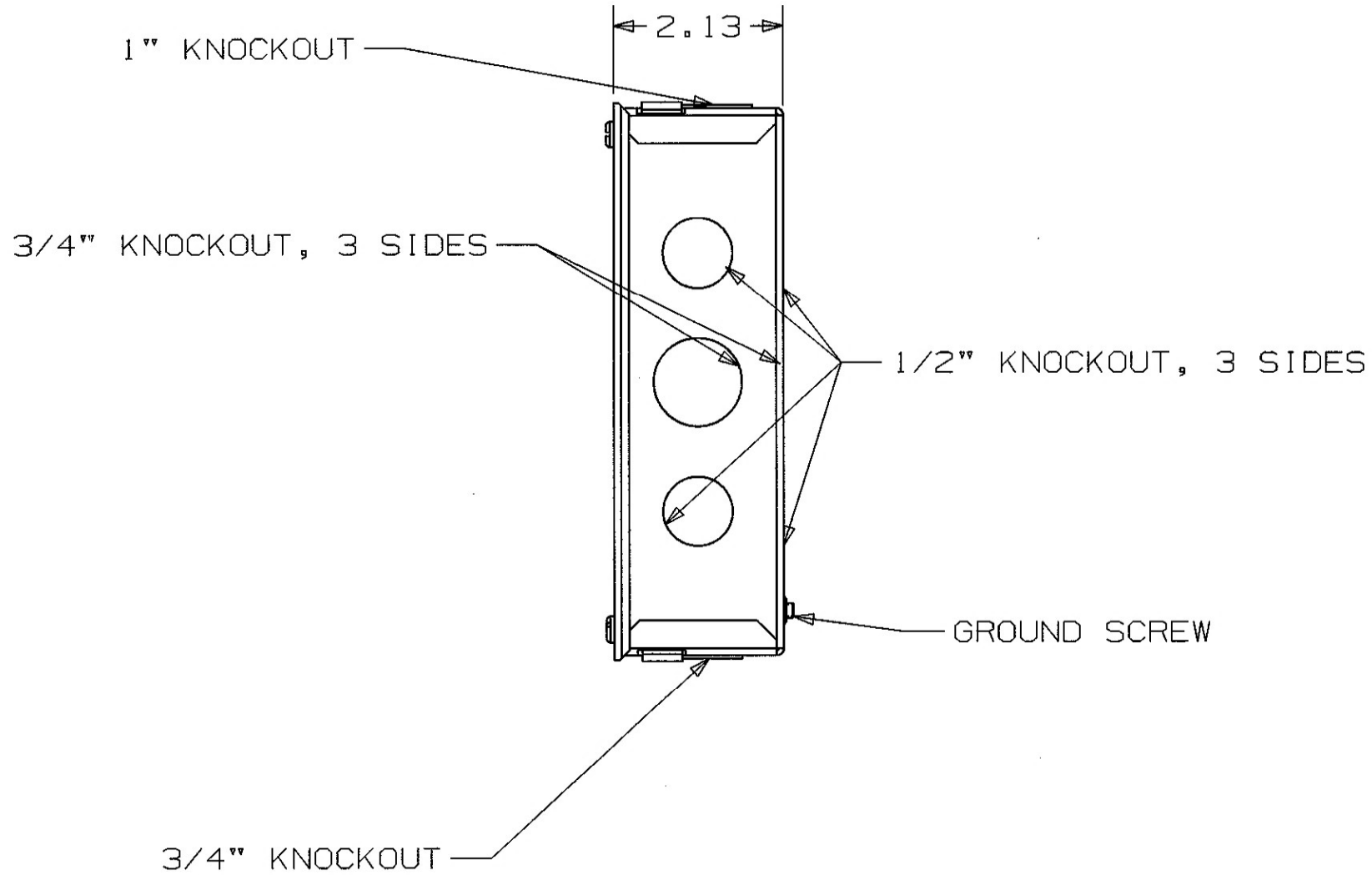
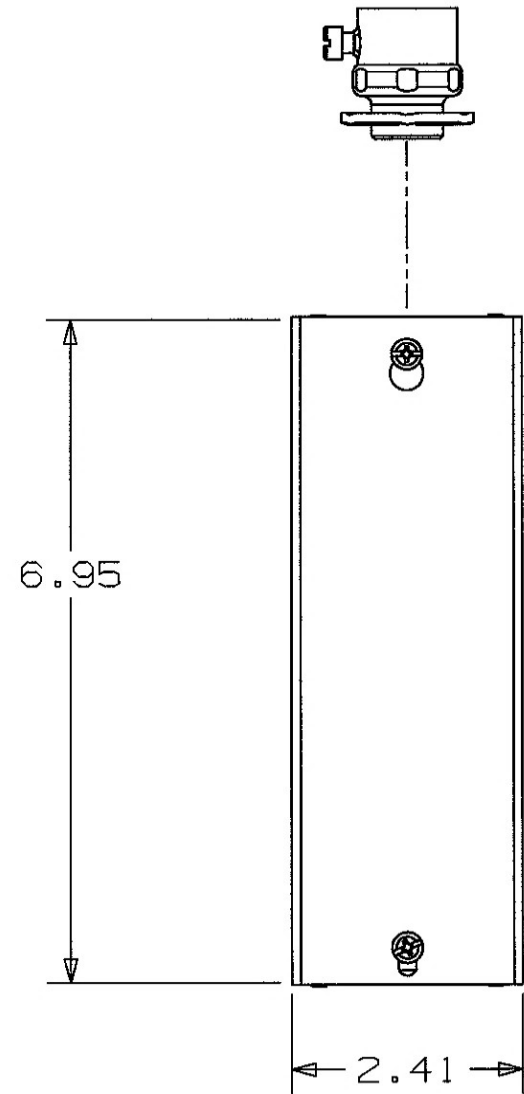

(1) 3/4" AND (1) 1" CONDUIT SUPPLIED LOOSE INSIDE JUNCTION BOX

NOTES:

- 1. BOX VOLUME: 27 IN³ / 442 CM³
- 2. PART IS UL/CUL LISTED

CODE 74545

LIST OF PARTS

DESCRIPTION	MATERIAL	FINISH
JUNCTION BOX COVER	STEEL	GALVANIZE
JUNCTION BOX	STEEL	GALVANIZE
#8 PAN HEAD SCREW	STEEL	ZINC
#10 GROUND SCREW	STEEL	GREEN FINISH
1" CONDUIT ADAPTOR	STEEL	ZINC
3/4" CONDUIT ADAPTOR	STEEL	ZINC

SYM	REVISIONS	APP	DATE
2	UPDATED KNOCKOUT DETAILS PER DCN 14930	SM	6/26/08
1	RELEASED PER DCN 14521		3/26/08

THE DESIGN AND DIMENSIONS OF THE PRODUCT SHOWN ON THIS DRAWING ARE SUBJECT TO CHANGE WITHOUT NOTICE

TITLE JUNCTION BOX ASSY SYSTEM ONE

TOLERANCES UNLESS OTHERWISE SPECIFIED FRACTIONS ±1/64 DECIMALS ±.005 ANGLES ±2°	WIRING DEVICE-KELLEMS HUBBELL INCORPORATED BRIDGEPORT, CT	
	DR. BY MSS	APP. BY SM
	TR. BY	SCALE 1:1
	CHK'D BY	DATE 3/26/08

DIMENSION SHEET FOR CAT. NO. M-11000
 SIFRPT JOB
 REPAIRABLE NON-REPAIRABLE
 B
 M-11000
 2