

# Baymaster™ and High Lumen LED Luminaire

## High Bay for Hazardous Locations

### NEC/CEC:

Class I, Division 2, Group A, B, C, D  
Class I, Zone 2 AEx/Ex ec Group IIC Gc  
Class I, Zone 2, Group IIC  
Class II, Division 1&2, Group E, F, G  
Class III

### NEC/CEC:

Zone 20 and 21 Group IIIC  
Zone 21, AEx/Ex tb Group IIIC Db  
Simultaneous Exposure  
Marine Outside Type (Salt Water) for USA Only

### NEC/CEC:

Wet Locations  
Type 3R, 4 and 4X  
IP66/67

### ATEX/IECEX:

Zone 2 and 21  
IP66  
II 3G 2D  
IK10  
Ex ec IIC T5

## Applications

- Enclosed and gasketed fixtures suitable for use in a wide range of industrial, chemical processing and other areas where flammable gases and vapors are present, for example:
  - Oil and Gas Refineries
  - Petrochemical Plants
  - Foundries
  - Drilling Rigs
  - Pulp and Paper Mills
  - Food and Beverage Processing Facilities
  - Loading Docks
  - Power Plants
  - Water and Wastewater Treatment Facilities
  - Other areas where corrosive, wet, dirty and tough environments are a problem.
- IP66/IP67, Type 4X, marine and wet locations. IP66 for IECEx/ATEX.
- Locations requiring dependable, consistent lighting in extreme hot/cold temperature environments. -40°C to +65°C (-40°F to +149°F) ambient temperature range. -40°C to +55°C (-40°F to +131°F) for high lumen BHLL3 output.
- Globally rated luminaires with all applicable certification labels for NEC/CEC and ATEX/IECEX environments. See Certifications and Compliances for details.

## Features

- Three lumen outputs provide up to 19,500 lumens.

Nominal Lumens ①	Wattage (W)	Efficacy (lpw)	HID Equivalent	Model Number
9,500	70	136	175-250W	<b>BLLL6</b>
15,000	111	135	250-400W	<b>BLLL7</b>
19,000	152	125	400-750W	<b>BLLL8</b>
24,000	177	136	1000W	<b>BHLL1</b>
30,000	221	136	1000-1500W	<b>BHLL2</b>
38,000	297	128	1500W	<b>BHLL3</b>

① Nominal lumen value for 5000K, Medium Beam, with clear glass. Detailed lumen information provided in tables.

- Choice of optics for optimal light distribution in a variety of applications.
- Separate field wiring compartment with screw terminal block for easy and secure connection (can accept UL/CSA 26-10AWG).
- Two 3/4" NPT entries provided. (Two close-up plugs provided when quick mount pendant system is ordered). Optional M20 metric adapters available.
- Unique quick mount pendant system allows for easy prewiring without supporting the High Bay in place. Quick mount adapter hood includes one 3/4" NPT entry.
- Alternate mounting system allows for "Y" cable mount and easy wiring via a separate field wiring compartment with a screw terminal block (can accept UL/CSA 26-10AWG).
- Choice of color temperature (CCT): 5000K cool white, 4000K neutral white, or 3000K warm white.
- Rugged and compact housing with superior thermal design translates to long luminaire life.
- Heavy duty, high temperature silicone rubber gaskets.
- Thermal shock and impact resistant clear or frosted glass lens.
- Standard 6KV surge protection. Optional 10kV additional surge protection available.

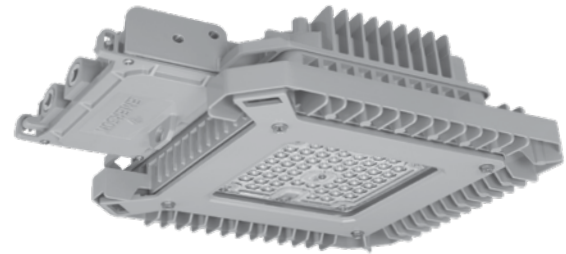

High Bay

- Captive fasteners secure one-piece lens.
- Field replaceable LED driver and lens cover.

## Options

- Improved safety cable design with multiple retention points, purchase separately.
- Guard and visor available, purchase separately
- Y mount cable assembly, purchase separately
- Drain assembly, purchase separately
- 10kV Surge Protection, for NEC/CEC only

## Standard Materials

- Housing, lens cover, quick mount body and hood: baked gray epoxy powder coat finish, electrostatically applied for complete uniform protection

## Standard Finishes

- Housing, lens cover, quick mount body and hood; baked gray epoxy powder coat finish, electrostatically applied for complete uniform protection

## Related Products

- Industrial Baymaster™ LED

LED/HIGH BAY: NEC/CEC ENCLOSED AND GASKETED

APPLETON

# Baymaster™ and High Lumen LED Luminaire

## High Bay for Hazardous Locations

**NEC/CEC:**

Class I, Division 2, Group A, B, C, D  
 Class I, Zone 2 AEx/Ex ec Group IIC Gc  
 Class I, Zone 2, Group IIC  
 Class II, Division 1&2, Group E, F, G  
 Class III

**NEC/CEC:**

Zone 20 and 21 Group IIIC  
 Zone 21, AEx/Ex tb Group IIIC Db  
 Simultaneous Exposure  
 Marine Outside Type (Salt Water) for  
 USA Only

**NEC/CEC:**

Wet Locations  
 Type 3R, 4 and 4X  
 IP66/67

**ATEX/IECEX:**

Zone 2 and 21  
 IP66  
 II 3G 2D  
 IK10  
 Ex ec IIC T5

### NEC/CEC Certifications and Compliances

- UL Standards:
  - UL844, Luminaires for Use in Hazardous Locations
  - UL1598, Luminaires
  - UL1598A, Luminaires for Installation on Marine Vessels
  - UL 8750, LED Equipment for Use in Lighting Products
- CSA Standards:
  - CSA C22.2 No. 250.0, Luminaires
  - CSA C22.2 No. 137, Luminaires for Use in Hazardous Locations
- cCSAus 164460 Certificate Number: BLL – 70073611, BHL – 70073613

### ATEX/IECEX Certifications and Compliances

- Certification Type: Baymaster LED
  - Gas: Zone 2
    - Type of Protection: Ex ec IIC Gc
    - Temperature Class: BLL – T5 to T3; BHL – T4 to T3
  - Dust: Zone 21
    - Type of Protection: Ex op is tb IIIC Db
    - Surface Temperature: +85°C to +100°C (+185°F to +212°F)
- Ambient Temperature: -40°C up to +65°C (-40°F up to +149 °F). -40°C to +55°C (-40°F to +131°F) for high lumen BHLL3 output
- ATEX Certificate: ITS18ATEX104171 Issue 01
- IECEX Certificate: IECEX ITS 18.0049\_1
- Index of Protection according EN/IEC 60529: IP66
- Impact Resistance (shock): IK10
- Photobiological Safety, IEC 62778 and IEC 62471: Risk Group 1 (RG1)

### DesignLights™ Consortium (for the following models)

- All models pending.

BLL

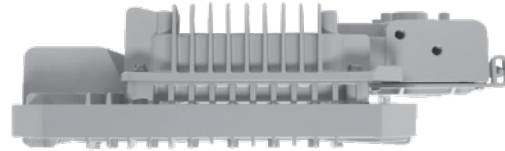

BLLP

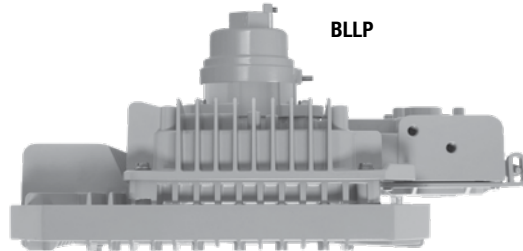

BHL

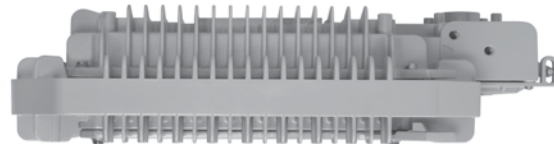

BHLP

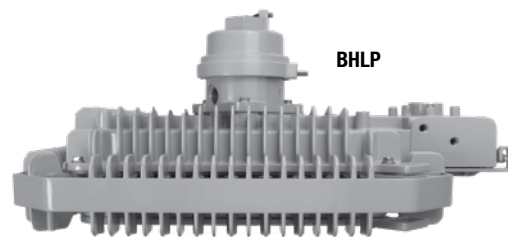

LED/HIGH BAY- NEC/CEC ENCLOSED AND GASKETED

APPLETON™

# Baymaster™ and High Lumen LED Luminaire

## High Bay for Hazardous Locations

**NEC/CEC:**

Class I, Division 2, Group A, B, C, D  
 Class I, Zone 2 AEx/Ex ec Group IIC Gc  
 Class I, Zone 2, Group IIC  
 Class II, Division 1&2, Group E, F, G  
 Class III

**NEC/CEC:**

Zone 20 and 21 Group IIIC  
 Zone 21, AEx/Ex tb Group IIIC Db  
 Simultaneous Exposure  
 Marine Outside Type (Salt Water) for  
 USA Only

**NEC/CEC:**

Wet Locations  
 Type 3R, 4 and 4X  
 IP66/67

**ATEX/IECEX:**

Zone 2 and 21  
 IP66  
 II 3G 2D  
 IK10  
 Ex ec IIC T5

### Illustrated Features

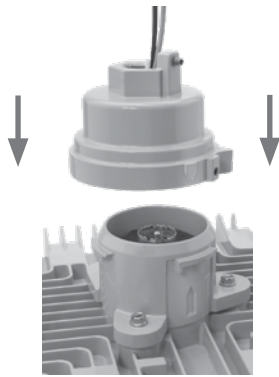

**Quick Mount Pendant System**

Appleton's patented quick mount pendant system allows for easy prewiring of a hood for quick, one person fixture installation. Simply align the arrows, push up, and rotate the luminaire a quarter turn until it locks into place. Specify quick mount pendant with a "P" in the fifth digit of the part number.



**Cable Mount Option**

The Baymaster High Bay can also be mounted with two Y style aircraft cables with spring clips, secured to eye bolts on the luminaire housing. Non quick mount models can be cable mounted and are wired through the 3/4" NPT entries in the wire box.



**Driver Assembly**

Replaceable drivers are waterproof (IP67) and offer standard 6kV surge protection and over temperature protection.

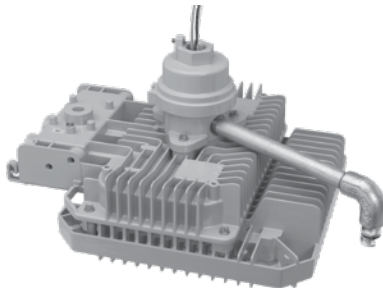

**Optional Drain Assembly**

Includes 9" long, 1/2" trade size conduit nipple, elbow and drain.

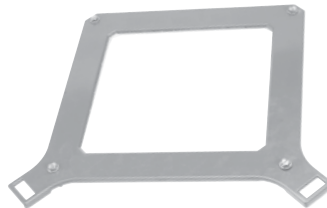

**Replaceable Cover Assembly**

The replaceable cover assembly is available with clear or frosted glass.

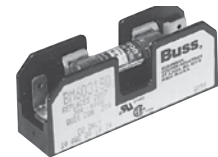

**Optional Fusing \***

Luminaire can be ordered with optional fusing. Fusing is not field installable.

\* Use of fuse voids marine rating.

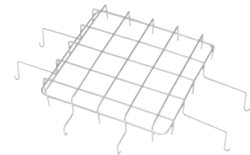

**Optional Wire Guard**

Stainless steel wire guard can be used for additional protection.

LED/HIGH BAY: NEC/CEC ENCLOSED AND GASKETED

APPLETON™

# Baymaster™ and High Lumen LED Luminaire

## High Bay for Hazardous Locations

**NEC/CEC:**

Class I, Division 2, Group A, B, C, D  
 Class I, Zone 2 AEx/Ex ec Group IIC Gc  
 Class I, Zone 2, Group IIC  
 Class II, Division 1&2, Group E, F, G  
 Class III

**NEC/CEC:**

Zone 20 and 21 Group IIIC  
 Zone 21, AEx/Ex tb Group IIIC Db  
 Simultaneous Exposure  
 Marine Outside Type (Salt Water) for  
 USA Only

**NEC/CEC:**

Wet Locations  
 Type 3R, 4 and 4X  
 IP66/67

**ATEX/IECEX:**

Zone 2 and 21  
 IP66  
 II 3G 2D  
 IK10  
 Ex ec IIC T5

Order using catalog numbering guides below or select catalog number from tables on following pages.

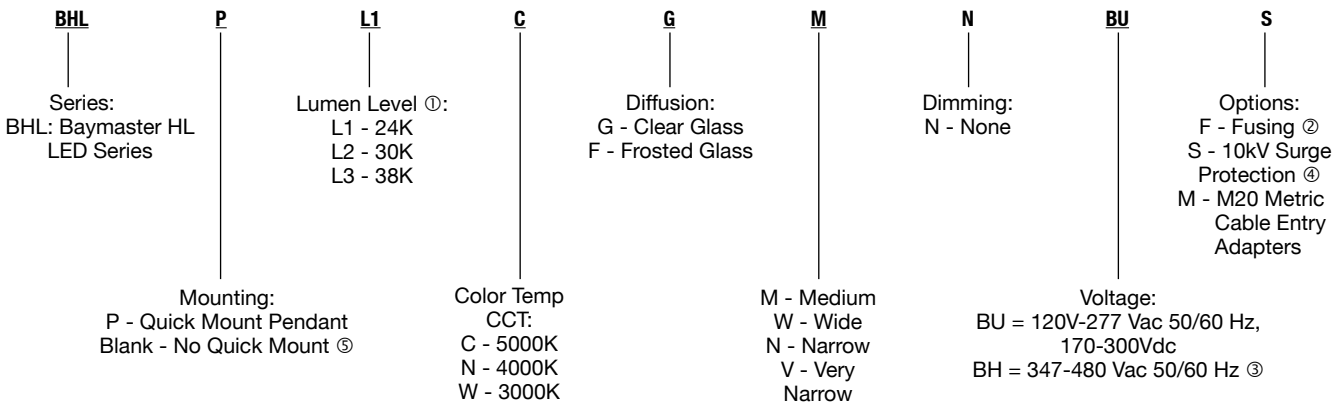
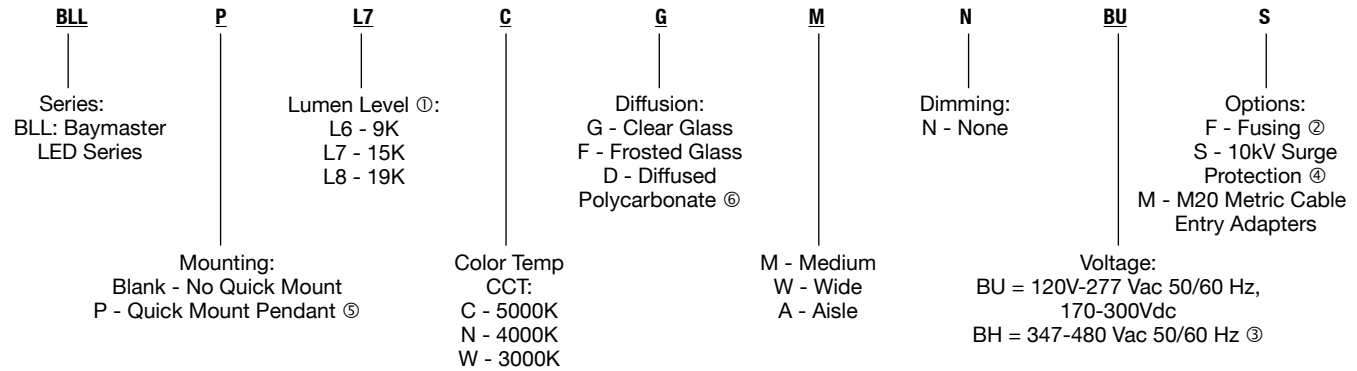

LED/HIGH BAY- NEC/CEC ENCLOSED AND GASKETED

APPLETON™

① All lumen values are typical (tolerance +/- 10%)

② Use of fuse voids Marine rating. Fusing available for NEC/CEC only.

③ BH voltage available for NEC/CEC only.

④ 10kV Surge Protection available for NEC/CEC only.

⑤ Quick mount pendant includes pre wired, factory installed, quick mount pendant body and hood. Models without the quick pendant mount are wired through the 3/4" NPT entries and a provided screw terminal block in the wiring compartment. Quick pendant mount available for NEC/CEC only.

⑥ Diffused polycarbonate available for NEC/CEC only.

# Baymaster™ and High Lumen LED Luminaire

## High Bay for Hazardous Locations

**NEC/CEC:**

Class I, Division 2, Group A, B, C, D  
 Class I, Zone 2 AEx/Ex ec Group IIC Gc  
 Class I, Zone 2, Group IIC  
 Class II, Division 1&2, Group E, F, G  
 Class III

**NEC/CEC:**

Zone 20 and 21 Group IIIC  
 Zone 21, AEx/Ex tb Group IIIC Db  
 Simultaneous Exposure  
 Marine Outside Type (Salt Water) for  
 USA Only

**NEC/CEC:**

Wet Locations  
 Type 3R, 4 and 4X  
 IP66/67

**ATEX/IECEX:**

Zone 2 and 21  
 IP66  
 II 3G 2D  
 IK10  
 Ex ec IIC T5

**Lumen Output Tables – BLL**

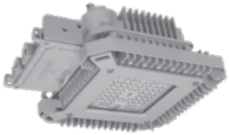
Diffusion	Color Temperature CCT	Lumen Output ①	Wattage	Efficacy (lm/W)	Optical Pattern	Catalog Number ②		
	5000K Cool White	9,900	70	141	Type V	BLLPL6CGMNBU		
		8,650		124	Type V Wide	BLLPL6CGWNBU		
		9,350		134	Type I Aisle	BLLPL6CGANBU		
		15,000		111	135	Type V	BLLPL7CGMNBU	
		13,150			118	Type V Wide	BLLPL7CGWNBU	
		14,250			128	Type I Aisle	BLLPL7CGANBU	
		19,500		152	128	Type V	BLLPL8CGMNBU	
	16,900	111	Type V		BLLPL8CGWNBU			
	18,350	121	Type I Aisle		BLLPL8CGANBU			
	Clear Glass	4000K Neutral White	9,000	70	129	Type V	BLLPL6NGMNBU	
			7,850		112	Type V Wide	BLLPL6NGWNBU	
			8,500		121	Type I Aisle	BLLPL6NGANBU	
			13,650		111	123	Type V	BLLPL7NGMNBU
			11,900			107	Type V Wide	BLLPL7NGWNBU
12,900			116			Type I Aisle	BLLPL7NGANBU	
17,550			152		115	Type V	BLLPL8NGMNBU	
15,350		101		Type V	BLLPL8NGWNBU			
16,650		110		Type I Aisle	BLLPL8NGANBU			
3000K Warm White		7,650	70	109	Type V	BLLPL6WGMNBU		
		6,700		96	Type V Wide	BLLPL6WGWNBU		
		7,250		104	Type I Aisle	BLLPL6WGANBU		
		11,500		111	104	Type V	BLLPL7WGMNBU	
		10,200			92	Type V Wide	BLLPL7WGWNBU	
	11,050	100			Type I Aisle	BLLPL8WGANBU		
	15,000	152		99	Type V	BLLPL8WGMNBU		
13,150	87		Type V	BLLPL8WGWNBU				
14,250	94	Type I Aisle	BLLPL8WGANBU					

LED/HIGH BAY: NEC/CEC ENCLOSED AND GASKETED

APPLETON

① All lumen values and wattage typical (tolerance +/- 10%)

② For 347-480 Vac voltage, change **-BU** suffix to **-BH**, example BLLPL7CGMNBH.

For 3/4" NPT to M20 metric adapters, add suffix **M** to end of part number, example BLLPL7CGMNBUM.

For Fusing option, add suffix **-F** to end of part number, example BLLPL7CGMNBUF.

For 10KV surge protection, add suffix **-S** to end of part number, example BLLPL7CGMNBUS.

For both Fusing and 10KV surge, add suffix **-FS** to end of part number, example BLLPL7CGMNBUSF.

For standard mounting option, remove **B** from prefix at being of part number, example BLL7CGMNBU.

See catalog numbering guide for certification restrictions.

# Baymaster™ and High Lumen LED Luminaire

## High Bay for Hazardous Locations

**NEC/CEC:**

Class I, Division 2, Group A, B, C, D  
 Class I, Zone 2 AEx/Ex ec Group IIC Gc  
 Class I, Zone 2, Group IIC  
 Class II, Division 1&2, Group E, F, G  
 Class III

**NEC/CEC:**

Zone 20 and 21 Group IIIC  
 Zone 21, AEx/Ex tb Group IIIC Db  
 Simultaneous Exposure  
 Marine Outside Type (Salt Water) for  
 USA Only

**NEC/CEC:**

Wet Locations  
 Type 3R, 4 and 4X  
 IP66/67

**ATEX/IECEX:**

Zone 2 and 21  
 IP66  
 II 3G 2D  
 IK10  
 Ex ec IIC T5

**Lumen Output Tables – BLL**

Diffusion	Color Temperature CCT	Lumen Output ①	Wattage	Efficacy (lm/W)	Optical Pattern	Catalog Number ②	
Frosted Glass	5000K Cool White	8,300	70	119	Type V	BLLPL6CFMNBU	
		6,800		97	Type V Wide	BLLPL6CFWNB	
		7,700		110	Type I Aisle	BLLPL6CFANBU	
		12,500	111	113	Type V	BLLPL7CFMNBU	
		10,350		93	Type V Wide	BLLPL7CFWNB	
		11,700		105	Type I Aisle	BLLPL7CFANBU	
		16,550	152	109	Type V	BLLPL8CFMNBU	
		13,250		87	Type V	BLLPL8CFWNB	
		15,000		99	Type I Aisle	BLLPL8CFANBU	
	4000K Neutral White	7,500	70	107	Type V	BLLPL6NFMNBU	
				6,150	88	Type V Wide	BLLPL6NFWNB
				6,950	99	Type I Aisle	BLLPL6NFANBU
		11,350	111	102	Type V	BLLPL7NFMNBU	
		9,350		84	Type V Wide	BLLPL7NFWNB	
		10,600		95	Type I Aisle	BLLPL7NFANBU	
14,500		152	95	Type V	BLLPL8NFMNBU		
12,000			79	Type V	BLLPL8NFWNB		
13,650			90	Type I Aisle	BLLPL8NFANBU		
3000K Warm White	6,400	70	91	Type V	BLLPL6WFMNBU		
			5,250	75	Type V Wide	BLLPL6WFWNB	
			5,950	85	Type I Aisle	BLLPL6WFANBU	
	9,700	111	87	Type V	BLLPL7WFMNBU		
	8,000		72	Type V Wide	BLLPL7WFWNB		
	9,100		82	Type I Aisle	BLLPL8WFANBU		
	12,500	152	82	Type V	BLLPL8WFMNBU		
	10,300		68	Type V	BLLPL8WFWNB		
	11,700		77	Type I Aisle	BLLPL8WFANBU		

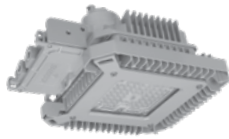

Frosted Glass

LED/HIGH BAY- NEC/CEC ENCLOSED AND GASKETED

APPLETON™

① All lumen values and wattage typical (tolerance +/- 10%)

② For 347-480 Vac voltage, change **-BU** suffix to **-BH**, example BLLPL7CGMNBH.

For 3/4" NPT to M20 metric adapters, add suffix **M** to end of part number, example BLLPL7CGMNBUM.

For Fusing option, add suffix **-F** to end of part number, example BLLPL7CGMNBUF.

For 10KV surge protection, add suffix **-S** to end of part number, example BLLPL7CGMNBUS.

For both Fusing and 10KV surge, add suffix **-FS** to end of part number, example BLLPL7CGMNBUSFS.

For standard mounting option, remove **B** from prefix at being of part number, example BLLPL7CGMNB.

See catalog numbering guide for certification restrictions.

# Baymaster™ and High Lumen LED Luminaire

## High Bay for Hazardous Locations

**NEC/CEC:**

Class I, Division 2, Group A, B, C, D  
 Class I, Zone 2 AEx/Ex ec Group IIC Gc  
 Class I, Zone 2, Group IIC  
 Class II, Division 1&2, Group E, F, G  
 Class III

**NEC/CEC:**

Zone 20 and 21 Group IIIC  
 Zone 21, AEx/Ex tb Group IIIC Db  
 Simultaneous Exposure  
 Marine Outside Type (Salt Water) for  
 USA Only

**NEC/CEC:**

Wet Locations  
 Type 3R, 4 and 4X  
 IP66/67

**ATEX/IECEX:**

Zone 2 and 21  
 IP66  
 II 3G 2D  
 IK10  
 Ex ec IIC T5

**Lumen Output Tables – BLL**

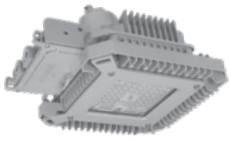
Diffusion	Color Temperature CCT	Lumen Output ①	Wattage	Efficacy (lm/W)	Optical Pattern	Catalog Number ②	
	5000K Cool White	8,050	70	115	Type V	BLLPL6CDMNBU	
		6,650		95	Type V Wide	BLLPL6CDWNBU	
		7,450		106	Type I Aisle	BLLPL6CDANBU	
		12,200	111	110	Type V	BLLPL7CDMNBU	
		10,150		91	Type V Wide	BLLPL7CDWNBU	
		11,350		102	Type I Aisle	BLLPL7CDANBU	
		15,650		103	Type V	BLLPL8CDMNBU	
	13,000	152	86	Type V	BLLPL8CDWNBU		
	14,650	96	Type I Aisle	BLLPL8CDANBU			
	Diffused Polycarbonate	4000K Neutral White	7,300	70	104	Type V	BLLPL6NDMNBU
			6,000		86	Type V Wide	BLLPL6NDWNBU
			6,750		96	Type I Aisle	BLLPL6NDANBU
			11,000	111	99	Type V	BLLPL7NDMNBU
			9,160		83	Type V Wide	BLLPL7NDWNBU
10,250			92		Type I Aisle	BLLPL7NDANBU	
14,150			93		Type V	BLLPL8NDMNBU	
11,800		152	78	Type V	BLLPL8NDWNBU		
13,250		87	Type I Aisle	BLLPL8NDANBU			
3000K Warm White		6,250	70	89	Type V	BLLPL6WDMNBU	
		5,150		74	Type V Wide	BLLPL6WDWNBU	
		5,750		82	Type I Aisle	BLLPL6WDANBU	
		9,450	111	85	Type V	BLLPL7WDMNBU	
		7,850		71	Type V Wide	BLLPL7WDWNBU	
	8,800	79		Type I Aisle	BLLPL8WDANBU		
	12,100	80		Type V	BLLPL8WDMNBU		
10,100	152	66	Type V	BLLPL8WDWNBU			
11,350	75	Type I Aisle	BLLPL8WDANBU				

LED/HIGH BAY: NEC/CEC ENCLOSED AND GASKETED

APPLETON

① All lumen values and wattage typical (tolerance +/- 10%)

② For 347-480 Vac voltage, change **-BU** suffix to **-BH**, example BLLPL7CGMNBH.

For 3/4" NPT to M20 metric adapters, add suffix **M** to end of part number, example BLLPL7CGMNBUM.

For Fusing option, add suffix **-F** to end of part number, example BLLPL7CGMNBUF.

For 10KV surge protection, add suffix **-S** to end of part number, example BLLPL7CGMNBUS.

For both Fusing and 10KV surge, add suffix **-FS** to end of part number, example BLLPL7CGMNBUSF.

For standard mounting option, remove **B** from prefix at being of part number, example BLLPL7CGMNB.

See catalog numbering guide for certification restrictions.

# Baymaster™ and High Lumen LED Luminaire

## High Bay for Hazardous Locations

**NEC/CEC:**

Class I, Division 2, Group A, B, C, D  
 Class I, Zone 2 AEx/Ex ec Group IIC Gc  
 Class I, Zone 2, Group IIC  
 Class II, Division 1&2, Group E, F, G  
 Class III

**NEC/CEC:**

Zone 20 and 21 Group IIIC  
 Zone 21, AEx/Ex tb Group IIIC Db  
 Simultaneous Exposure  
 Marine Outside Type (Salt Water) for  
 USA Only

**NEC/CEC:**

Wet Locations  
 Type 3R, 4 and 4X  
 IP66/67

**ATEX/IECEx:**

Zone 2 and 21  
 IP66  
 II 3G 2D  
 IK10  
 Ex ec IIC T5

**Lumen Output Tables – BHL**

Diffusion	Color Temperature CCT	Lumen Output ①	Wattage	Efficacy (lm/W)	Optical Pattern	Catalog Number ②	
Clear Glass	5000K Cool White	24,250	178	136	Type V	BHLPL1CGMNBU	
		21,000		118	Type V Wide	BHLPL1CGWNBU	
		25,000		140	Type V Narrow	BHLPL1CGNNBU	
		22,750	222	128	Type V Very Narrow	BHLPL1CGVNBUB	
		29,750		134	Type V	BHLPL2CGMNBU	
		25,650		116	Type V Wide	BHLPL2CGWNBU	
		30,000		135	Type V Narrow	BHLPL2CGNNBU	
		27,500		124	Type V Very Narrow	BHLPL2CGVNBUB	
		37,400		126	Type V	BHLPL3CGMNBU	
	32,400	298	109	Type V Wide	BHLPL3CGWNBU		
	37,500		126	Type V Narrow	BHLPL3CGNNBU		
	34,750		117	Type V Very Narrow	BHLPL3CGVNBUB		
	Clear Glass	4000K Neutral White	21,300	178	120	Type V	BHLPL1NGMNBU
			18,800		106	Type V Wide	BHLPL1NGWNBU
			21,900		123	Type V Narrow	BHLPL1NGNNBU
			20,250	222	114	Type V Very Narrow	BHLPL1NGVNBUB
			26,100		118	Type V	BHLPL2NGMNBU
			22,850		103	Type V Wide	BHLPL2NGWNBU
26,700			120		Type V Narrow	BHLPL2NGNNBU	
24,600			111		Type V Very Narrow	BHLPL2NGVNBUB	
32,800			110		Type V	BHLPL3NGMNBU	
28,850		298	97	Type V Wide	BHLPL3NGWNBU		
33,600			113	Type V Narrow	BHLPL3NGNNBU		
30,950			104	Type V Very Narrow	BHLPL3NGVNBUB		
3000K Warm White		20,100	178	113	Type V	BHLPL1WGMNBU	
		17,900		101	Type V Wide	BHLPL1WGWNBU	
		20,850		117	Type V Narrow	BHLPL1WGNNBU	
		19,350	222	109	Type V Very Narrow	BHLPL1WGVNBUB	
		24,650		111	Type V	BHLPL2WGMNBU	
		21,800		98	Type V Wide	BHLPL2WGWNBU	
	25,500	115		Type V Narrow	BHLPL2WGNNBU		
	23,450	106		Type V Very Narrow	BHLPL2WGVNBUB		
	31,000	104		Type V	BHLPL3WGMNBU		
27,550	298	92	Type V Wide	BHLPL3WGWNBU			
32,000		107	Type V Narrow	BHLPL3WGNNBU			
29,500		99	Type V Very Narrow	BHLPL3WGVNBUB			

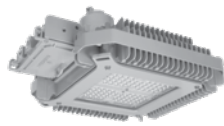

Clear Glass

4000K Neutral White

3000K Warm White

LED/HIGH BAY- NEC/CEC ENCLOSED AND GASKETED

APPLETON™

① All lumen values and wattage typical (tolerance +/- 10%)  
 ② For 347-480 Vac voltage, change **-BU** suffix to **-BH**, example BHLPL7CGMNBH.  
 For 3/4" NPT to M20 metric adapters, add suffix **M** to end of part number, example BHLPL7CGMNBUM.  
 For Fusing option, add suffix **-F** to end of part number, example BHLPL7CGMNBUF.  
 For 10KV surge protection, add suffix **-S** to end of part number, example BHLPL7CGMNBUS.  
 For both Fusing and 10KV surge, add suffix **-FS** to end of part number, example BHLPL7CGMNBUSF.  
 For standard mounting option, remove **B** from prefix at being of part number, example BHLL7CGMNBUB.  
 See catalog numbering guide for certification restrictions.



# Baymaster™ and High Lumen LED Luminaire

## High Bay for Hazardous Locations

**NEC/CEC:**

Class I, Division 2, Group A, B, C, D  
 Class I, Zone 2 AEx/Ex ec Group IIC Gc  
 Class I, Zone 2, Group IIC  
 Class II, Division 1&2, Group E, F, G  
 Class III

**NEC/CEC:**

Zone 20 and 21 Group IIIC  
 Zone 21, AEx/Ex tb Group IIIC Db  
 Simultaneous Exposure  
 Marine Outside Type (Salt Water) for  
 USA Only

**NEC/CEC:**

Wet Locations  
 Type 3R, 4 and 4X  
 IP66/67

**ATEX/IECEX:**

Zone 2 and 21  
 IP66  
 II 3G 2D  
 IK10  
 Ex ec IIC T5

**Lumen Output Tables – BLL**

Diffusion	Color Temperature CCT	Lumen Output ①	Wattage	Efficacy (lm/W)	Optical Pattern	Catalog Number ②	
	5000K Cool White	20,500	178	115	Type V	BHLPL1CFMNBU	
		16,700		94	Type V Wide	BHLPL1CFWNBU	
		21,550		121	Type V Narrow	BHLPL1CFNNUBU	
		20,000		112	Type V Very Narrow	BHLPL1CFVNUBU	
		25,000	222	113	Type V	BHLPL2CFMNBU	
		20,350		92	Type V Wide	BHLPL2CFWNBU	
		26,000		117	Type V Narrow	BHLPL2CFNNUBU	
		24,750		111	Type V Very Narrow	BHLPL2CFVNUBU	
		31,500		106	Type V	BHLPL3CFMNBU	
		25,700		298	86	Type V Wide	BHLPL3CFWNBU
	33,500	112	Type V Narrow		BHLPL3CFNNUBU		
	31,000	104	Type V Very Narrow		BHLPL3CFVNUBU		
	18,000	178	101		Type V	BHLPL1NFMNBU	
	14,850		83	Type V Wide	BHLPL1NFWNBU		
	19,350		109	Type V Narrow	BHLPL1NFNNUBU		
	17,950		101	Type V Very Narrow	BHLPL1NFVNUBU		
	Frosted Glass	4000K Neutral White	21,950	222	99	Type V	BHLPL2NFMNBU
			18,000		81	Type V Wide	BHLPL2NFWNBU
			23,600		106	Type V Narrow	BHLPL2NFNNUBU
			21,950		99	Type V Very Narrow	BHLPL2NFVNUBU
27,700			93		Type V	BHLPL3NFMNBU	
22,800		298	77	Type V Wide	BHLPL3NFWNBU		
29,750			100	Type V Narrow	BHLPL3NFNNUBU		
27,500			92	Type V Very Narrow	BHLPL3NFVNUBU		
16,850			178	95	Type V	BHLPL1WFMNBU	
14,250				80	Type V Wide	BHLPL1WFWNBU	
18,600	104	Type V Narrow		BHLPL1WFNNUBU			
17,200	97	Type V Very Narrow		BHLPL1WVNUBU			
3000K Warm White	20,550	222	93	Type V	BHLPL2WFMNBU		
			17,350	78	Type V Wide	BHLPL2WFWNBU	
			22,650	102	Type V Narrow	BHLPL2WFNNUBU	
	21,000	298	95	Type V Very Narrow	BHLPL2WVNUBU		
	26,000		87	Type V	BHLPL3WFMNBU		
	21,900		73	Type V Wide	BHLPL3WFWNBU		
	28,600		96	Type V Narrow	BHLPL3WFNNUBU		
26,400	89	Type V Very Narrow	BHLPL3WVNUBU				

LED/HIGH BAY: NEC/CEC ENCLOSED AND GASKETED

APPLETON

① All lumen values and wattage typical (tolerance +/- 10%)

② For 347-480 Vac voltage, change -BU suffix to -BH, example BHLPL7CGMNBH.

For 3/4" NPT to M20 metric adapters, add suffix M to end of part number, example BHLPL7CGMNBUM.

For Fusing option, add suffix -F to end of part number, example BHLPL7CGMNBUF.

For 10KV surge protection, add suffix -S to end of part number, example BHLPL7CGMNBUS.

For both Fusing and 10KV surge, add suffix -FS to end of part number, example BHLPL7CGMNBUSFS.

For standard mounting option, remove B from prefix at being of part number, example BHLL7CGMNB.

See catalog numbering guide for certification restrictions.

# Baymaster™ and High Lumen LED Luminaire

## High Bay for Hazardous Locations

**NEC/CEC:**

Class I, Division 2, Group A, B, C, D  
 Class I, Zone 2 AEx/Ex ec Group IIC Gc  
 Class I, Zone 2, Group IIC  
 Class II, Division 1&2, Group E, F, G  
 Class III

**NEC/CEC:**

Zone 20 and 21 Group IIIC  
 Zone 21, AEx/Ex tb Group IIIC Db  
 Simultaneous Exposure  
 Marine Outside Type (Salt Water) for  
 USA Only

**NEC/CEC:**

Wet Locations  
 Type 3R, 4 and 4X  
 IP66/67

**ATEX/IECEX:**

Zone 2 and 21  
 IP66  
 II 3G 2D  
 IK10  
 Ex ec IIC T5

**Electrical Ratings ①**

Voltage Suffix	Voltage (V)	Input Power (Watts)	Input Current (Amps)	Power Factor (PF)	Total Harmonic Distortion (THD)	Model Number
<b>BLL</b>						
BU	120 Vac	73	0.62	>.9	<20%	BLLL6 BLLPL6
	277 Vac	71	0.27			
	170 Vdc	69	0.41	N/A	N/A	
	300 Vdc	68	0.23			
BH	347 Vac	71	0.21	>.9	<20%	
	480 Vac	71	0.16			
BU	120 Vac	111	0.94	>.9	<20%	BLLL7 BLLPL7
	277 Vac	106	0.43			
	170 Vdc	113	0.67	N/A	N/A	
	300 Vdc	111	0.37			
BH	347 Vac	115	0.33	>.9	<20%	
	480 Vac	115	0.25			
BU	120 Vac	154	1.30	>.9	<20%	BLLL8 BLLPL8
	277 Vac	146	0.56			
	170 Vdc	156	0.92	N/A	N/A	
	300 Vdc	152	0.51			
BH	347 Vac	150	0.43	>.9	<20%	
	480 Vac	149	0.32			
<b>BHL</b>						
BU	120 Vac	180	1.52	>.9	<20%	BHLL1 BHLPL1
	277 Vac	176	0.67			
	170 Vdc	172	1.02	N/A	N/A	
	300 Vdc	170	0.57			
BH	347 Vac	179	0.52	>.9	<20%	
	480 Vac	179	0.39			
BU	120 Vac	231	1.94	>.9	<20%	BHLL2 BHLPL2
	277 Vac	231	0.88			
	170 Vdc	220	1.30	N/A	N/A	
	300 Vdc	217	0.72			
BH	347 Vac	219	0.64	>.9	<20%	
	480 Vac	219	0.47			
BU	120 Vac	317	2.67	>.9	<20%	BHLL3 BHLPL3
	277 Vac	303	1.15			
	170 Vdc	305	1.80	N/A	N/A	
	300 Vdc	298	0.99			
BH	347 Vac	299	0.87	>.9	<20%	
	480 Vac	298	0.63			

LED/HIGH BAY- NEC/CEC ENCLOSED AND GASKETED

APPLETON™

Surge Protection: Integral 6KV surge protection. Option for up to 10KV surge protection. (cCSAus only).

① All ratings are typical.

# Baymaster™ and High Lumen LED Luminaire

## High Bay for Hazardous Locations

**NEC/CEC:**

Class I, Division 2, Group A, B, C, D  
 Class I, Zone 2 AEx/Ex ec Group IIC Gc  
 Class I, Zone 2, Group IIC  
 Class II, Division 1&2, Group E, F, G  
 Class III

**NEC/CEC:**

Zone 20 and 21 Group IIIC  
 Zone 21, AEx/Ex tb Group IIIC Db  
 Simultaneous Exposure  
 Marine Outside Type (Salt Water) for  
 USA Only

**NEC/CEC:**

Wet Locations  
 Type 3R, 4 and 4X  
 IP66/67

**ATEX/IECEX:**

Zone 2 and 21  
 IP66  
 II 3G 2D  
 IK10  
 Ex ec IIC T5

**NEC/CEC Temperature Codes**

Series Number	Max Driver Current (mA)	Max Ambient C° (F°)	Gas		Dust		Combined Class I, Division 2 & Class II, Division 1	Gas Ex ec IIC, Class I, Zone 2, AEx ec IIC	Dust Ex tb IIIC, Zone 21, AEx tb IIIC
			Class I, Division 2 Groups A, B, C and D	Class I Zone 2 Group IIC	Class II, Division 1, Groups E, F and G	Zone 20, Group IIIC			
BLLL6	410	40 (104)	T5	T5	T6	T6	T4A	T5	T85 °C
		55 (131)	T4A	T4	T6	T6	T4A	T4	T85 °C
		65 (149)	T4A	T4	T6	T6	T4	T4	T85 °C
BLLL7	680	40 (104)	T4	T4	T6	T6	T4	T4	T85 °C
		55 (131)	T3C	T3	T6	T6	T3C	T3	T85 °C
		65 (149)	T3C①	T3①	T5①	T5①	T3C①	T3②	T100 °C②
BLLL8	930	40 (104)	T3C	T3	T6	T6	T3C	T3	T85 °C
		55 (131)	T3B①	T3①	T5①	T5①	T3A①	T3①	T100 °C②
		65 (149)	T3A①	T3①	T5①	T5①	T3A①	T3①	T100 °C②
BHLL1	530	40 (104)	T4A	T4	T6/T5③	T6/T5③	T4A	T4	T85°C/ T100°C③
		55 (131)	T4A	T4	T6/T5③	T6/T5③	T4A	T4	T85°C/ T100°C③
		65 (149)	T4	T4	T5③	T5③	T4	T4	T100°C
BHLL2	680	40 (104)	T4	T4	T6/T5③	T6/T5③	T4	T4	T85°C/ T100°C③
		55 (131)	T4	T4	T5③	T5③	T4	T4	T100°C
		65 (149)	T3C	T3	T5③	T5③	T4	T3	T100°C
BHLL3	915	40 (104)	T3C	T3	T6/T5③	T6/T5③	T3C	T3	T85°C/ T100°C③
		55 (131)	T3C	T3	T5③	T5③	T3C	T3	T100°C
		65 (149)	—	—	—	—	—	—	—

**ATEX/IECEX Temperature Codes**

Model Number	Max Driver Current (mA)	Gas T Rating			Dust Surface Temperature		
		+40°C (+104°F)	+55°C (+131°F)	+65°C (+149°F)	+40°C (+104°F)	+55°C (+131°F)	+65°C (+149°F)
BLLL6	410	T5	T4	T4	T85°C	T85°C	T85°C
BLLL7	680	T4	T3	T3	T85°C	T85°C	T100°C
BLLL8	930	T3	T3	T3	T85°C	T100°C	T100°C
BHLL1	530	T4	T4	T3	T85°C④	T85°C④	T85°C④
BHLL2	680	T4	T4	T3	T85°C④	T100°C	T100°C
BHLL3	915	T4	T3	—	T100°C	T100°C	—

Supply Wire Temperature for all: 90°C, 194°F

① Diffused polycarbonate lens option is not certified for these ambient temperature and lumen output combinations. Diffused polycarbonate not available for BHL high lumen series.

② Diffused polycarbonate lens is certified for NEC/CEC only. No face up orientation for installation.

③ T5 is maximum allowed temperature code, and T100°C is maximum allowed temperature, when model number includes 3x3 secondary optic

④ Baymaster High Lumen with Very Narrow secondary optic surface temperature is T100°C for these ranges.

⑤ For input voltages of 125-169 VDC, an ambient temperature exceeding 55°C is not permitted.

# Baymaster™ and High Lumen LED Luminaire

## High Bay for Hazardous Locations

**NEC/CEC:**

Class I, Division 2, Group A, B, C, D  
 Class I, Zone 2 AEx/Ex ec Group IIC Gc  
 Class I, Zone 2, Group IIC  
 Class II, Division 1&2, Group E, F, G  
 Class III

**NEC/CEC:**

Zone 20 and 21 Group IIIC  
 Zone 21, AEx/Ex tb Group IIIC Db  
 Simultaneous Exposure  
 Marine Outside Type (Salt Water) for  
 USA Only







**NEC/CEC:**

Wet Locations  
 Type 3R, 4 and 4X  
 IP66/67

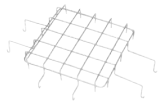
**ATEX/IECEX:**

Zone 2 and 21  
 IP66  
 II 3G 2D  
 IK10  
 Ex ec IIC T5

### Accessories and Replacement Parts

	Description	Catalog Number
<b>Quick-Connect Pendant Hood Replacement</b>		
	Baymaster Quick-Connect Pendant Hood Replacement	<b>BMQCPH</b>
	Stainless steel	<b>LGGUARD</b> <b>LHGUARD</b>
<b>Safety Cable</b>		
	Stainless steel	<b>LEDSC</b>
<b>Drain</b>		
	9" long, 1/2" trade size drain assembly for use with quick mount pendant hood	<b>LEDDR9</b>
<b>Y Mounting Cable</b>		
	1.5 M (5 ft.) cable mount - stainless steel Includes two (5 ft.) Y cables with spring clips and four eye bolts	<b>LEDC5</b>
<b>Safety Support Hooks</b>		
	3/4" malleable iron hook and loop	<b>EFHM-75</b>
<b>Replacement Covers</b>		
	Diffused Polycarbonate replacement cover	<b>BLLDIFFP</b>
	Clear replacement cover High Lumen	<b>BHLCLEAR</b>
	Frosted replacement cover High Lumen	<b>BHLFROST</b>

LED/HIGH BAY- NEC/CEC ENCLOSED AND GASKETED

APPLETON™

# Baymaster™ and High Lumen LED Luminaire

## High Bay for Hazardous Locations

**NEC/CEC:**

Class I, Division 2, Group A, B, C, D  
 Class I, Zone 2 AEx/Ex ec Group IIC Gc  
 Class I, Zone 2, Group IIC  
 Class II, Division 1&2, Group E, F, G  
 Class III

**NEC/CEC:**

Zone 20 and 21 Group IIIC  
 Zone 21, AEx/Ex tb Group IIIC Db  
 Simultaneous Exposure  
 Marine Outside Type (Salt Water) for  
 USA Only



**NEC/CEC:**

Wet Locations  
 Type 3R, 4 and 4X  
 IP66/67

**ATEX/IECEX:**

Zone 2 and 21  
 IP66  
 II 3G 2D  
 IK10  
 Ex ec IIC T5

### Replacement Drivers

	Voltage	Driver Wattage	Constant Current Setting	Luminaire Model	CCT	Catalog Number
	BU	100 watt	410mA	BLLL6C/ BLLPL6C BLLL6W/ BLLPL6W	5000K and 3000K	APMS100C105UD41
	BH					APMS100C105HD41
	BU	150 watt	650mA	BLLL7W/ BLLPL7W	3000K	APMS150C105UD65
	BH					APMS150C105HD65
	BU	150 watt	680mA	BLLL7C/ BLLPL7C	5000K	APMS150C105UD68
	BH					APMS150C105HD68
	BU	150 watt	890mA	BLLL8W/ BLLPL8W	3000K	APMS150C105UD89
	BH					APMS150C105HD89
BU	150 watt	930mA	BLLL8C/ BLLPL8C	5000K	APMS150C105HD93	
BH					APMS150C105HD93	

### Baymaster Accessory Weights

Description	Weight in kg (lbs)
BLLL6/BLLPL6, BLL7/BLLPL7, BLL8/BLLPL8 Luminaires	9.8 (21.6)
BHLL1/BHLPL1, BHLL2/BHLPL2, BHLL3/BHLPL3 Luminaires	16.1 (35.4)
Quick Mount Hood	0.4 (0.9)
Guard	0.2 (0.4)
Safety Cable	0.2 (0.4)
Drain	0.5 (1.2)
Y Cable Mount	0.5 (1.2)

LED/HIGH BAY: NEC/CEC ENCLOSED AND GASKETED

APPLETON™

# Baymaster™ and High Lumen LED Luminaire

## High Bay for Hazardous Locations

**NEC/CEC:**

Class I, Division 2, Group A, B, C, D  
 Class I, Zone 2 AEx/Ex ec Group IIC Gc  
 Class I, Zone 2, Group IIC  
 Class II, Division 1&2, Group E, F, G  
 Class III

**NEC/CEC:**

Zone 20 and 21 Group IIIC  
 Zone 21, AEx/Ex tb Group IIIC Db  
 Simultaneous Exposure  
 Marine Outside Type (Salt Water) for  
 USA Only

**NEC/CEC:**

Wet Locations  
 Type 3R, 4 and 4X  
 IP66/67

**ATEX/IECEx:**

Zone 2 and 21  
 IP66  
 II 3G 2D  
 IK10  
 Ex ec IIC T5

Dimensions in Millimeters (Inches)

High Bay – With Quick Mount Pendant System

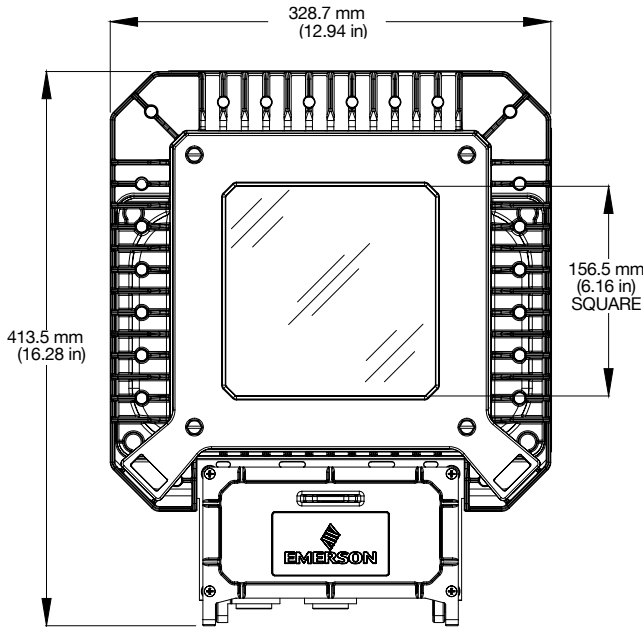

**BLLP Models**

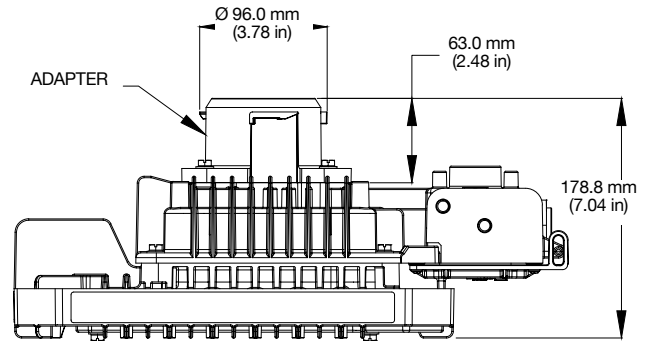

LED/HIGH BAY- NEC/CEC ENCLOSED AND GASKETED

APPLETON™

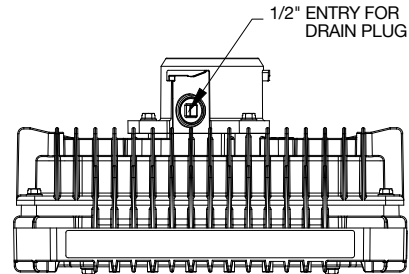
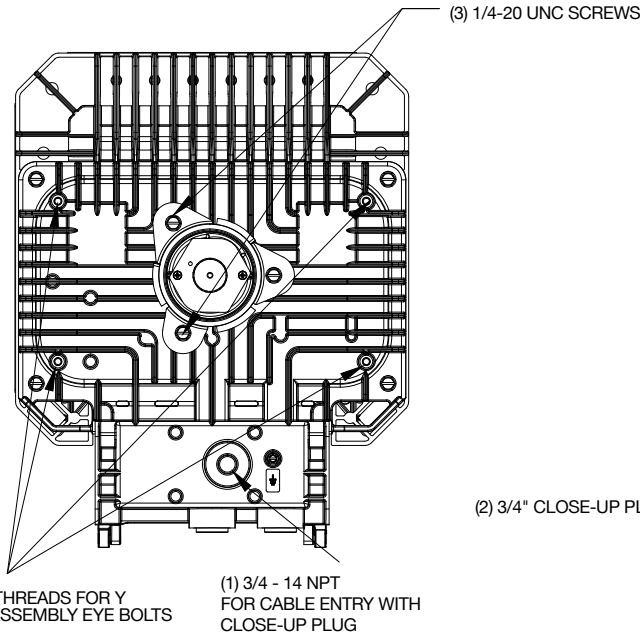

**BLLP Models**

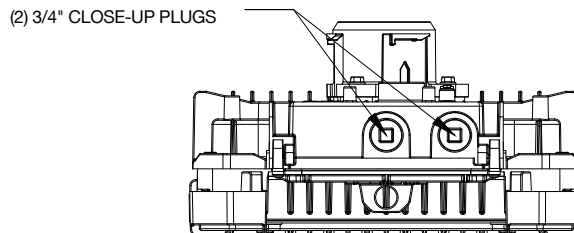

# Baymaster™ and High Lumen LED Luminaire

## High Bay for Hazardous Locations

**NEC/CEC:**

Class I, Division 2, Group A, B, C, D  
 Class I, Zone 2 AEx/Ex ec Group IIC Gc  
 Class I, Zone 2, Group IIC  
 Class II, Division 1&2, Group E, F, G  
 Class III

**NEC/CEC:**

Zone 20 and 21 Group IIIC  
 Zone 21, AEx/Ex tb Group IIIC Db  
 Simultaneous Exposure  
 Marine Outside Type (Salt Water) for  
 USA Only

**NEC/CEC:**

Wet Locations  
 Type 3R, 4 and 4X  
 IP66/67

**ATEX/IECEx:**

Zone 2 and 21  
 IP66  
 II 3G 2D  
 IK10  
 Ex ec IIC T5

**Dimensions in Millimeters (Inches)**

**High Bay – No Mount**

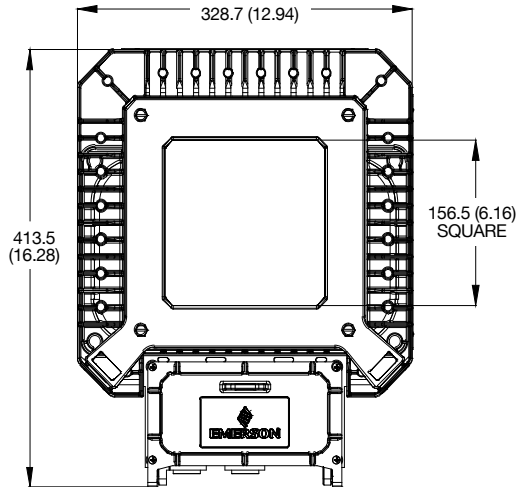

**Front View**

**BLL Models**

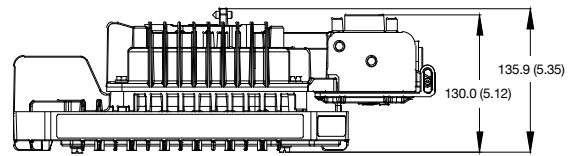

**Side View**

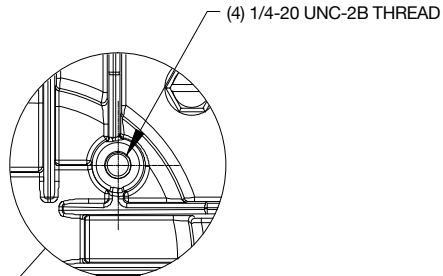
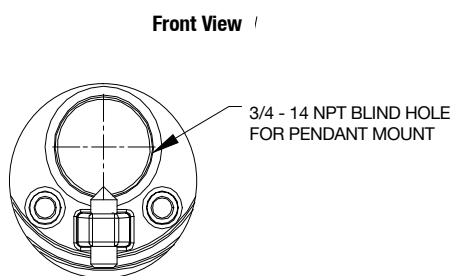

**BLL Models**

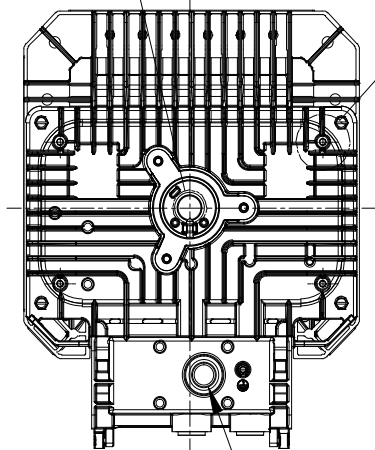

**Back View**

(1) 3/4 - 14 NPT FOR CABLE ENTRY WITH CLOSE-UP PLUG

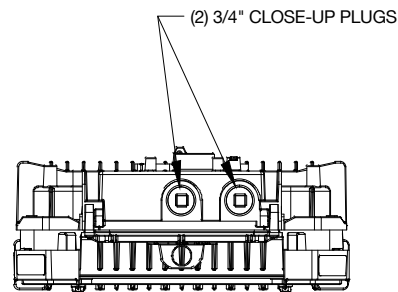

**Bottom View**

LED/HIGH BAY: NEC/CEC ENCLOSED AND GASKETED

APPLETON

# Baymaster™ and High Lumen LED Luminaire

## High Bay for Hazardous Locations

**NEC/CEC:**

Class I, Division 2, Group A, B, C, D  
 Class I, Zone 2 AEx/Ex ec Group IIC Gc  
 Class I, Zone 2, Group IIC  
 Class II, Division 1&2, Group E, F, G  
 Class III

**NEC/CEC:**

Zone 20 and 21 Group IIIC  
 Zone 21, AEx/Ex tb Group IIIC Db  
 Simultaneous Exposure  
 Marine Outside Type (Salt Water) for  
 USA Only

**NEC/CEC:**

Wet Locations  
 Type 3R, 4 and 4X  
 IP66/67

**ATEX/IECEX:**

Zone 2 and 21  
 IP66  
 II 3G 2D  
 IK10  
 Ex ec IIC T5

Dimensions in Millimeters (Inches)

High Bay – With Quick Mount Pendant System

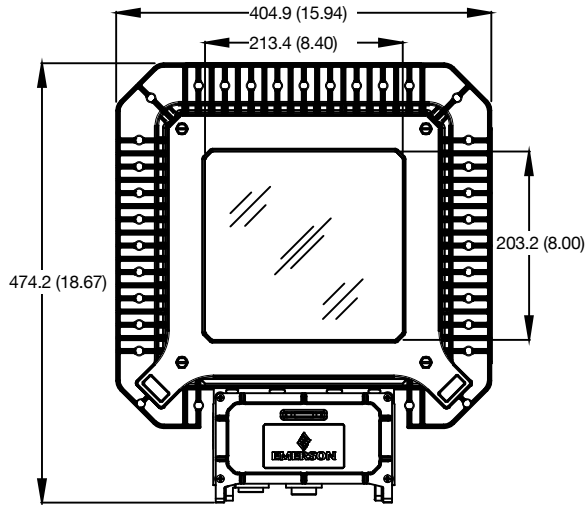

Front View

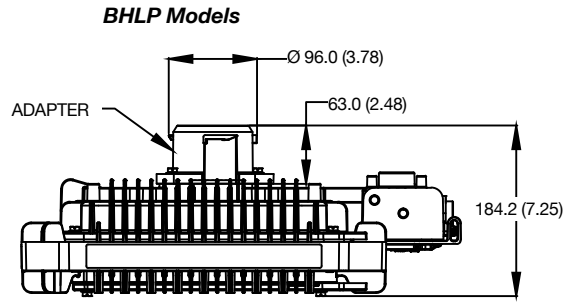

Side View

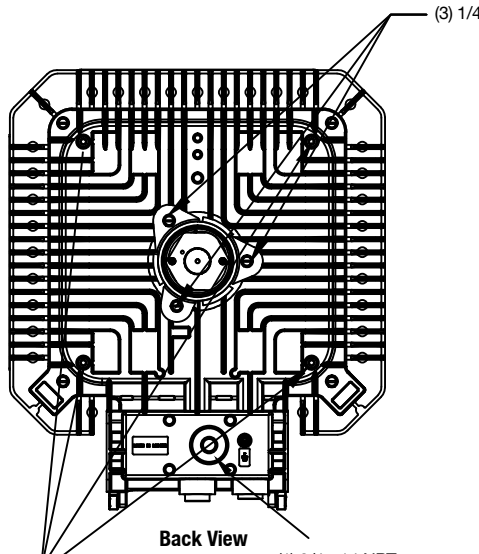

Back View

(4) 1/4-20 THREADS FOR Y  
 CABLE ASSEMBLY EYE BOLTS

(1) 3/4 - 14 NPT  
 FOR CABLE ENTRY WITH  
 CLOSE-UP PLUG

(3) 1/4-20 UNC SCREWS

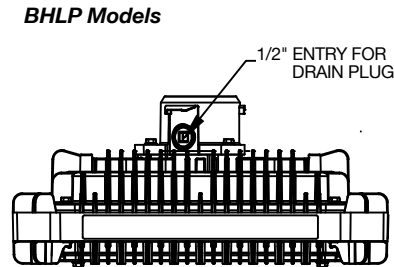

Top View

(2) 3/4" CLOSE-UP  
 PLUGS

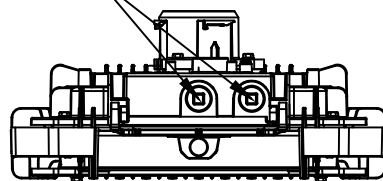

Bottom View

LED/HIGH BAY- NEC/CEC ENCLOSED AND GASKETED

APPLETON™



# Baymaster™ and High Lumen LED Luminaire

## High Bay for Hazardous Locations

**NEC/CEC:**

Class I, Division 2, Group A, B, C, D  
 Class I, Zone 2 AEx/Ex ec Group IIC Gc  
 Class I, Zone 2, Group IIC  
 Class II, Division 1&2, Group E, F, G  
 Class III

**NEC/CEC:**

Zone 20 and 21 Group IIIC  
 Zone 21, AEx/Ex tb Group IIIC Db  
 Simultaneous Exposure  
 Marine Outside Type (Salt Water) for USA Only

**NEC/CEC:**

Wet Locations  
 Type 3R, 4 and 4X  
 IP66/67

**ATEX/IECEX:**

Zone 2 and 21  
 IP66  
 II 3G 2D  
 IK10  
 Ex ec IIC T5

**Dimensions in Millimeters (Inches)**

**High Bay – No Mount**

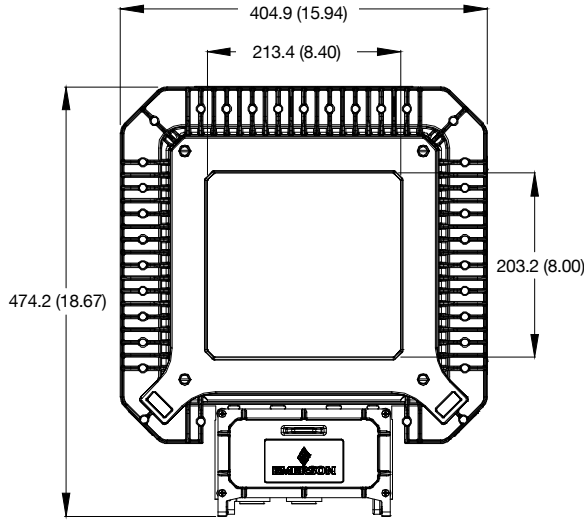

**Front View**

**BHL Models**

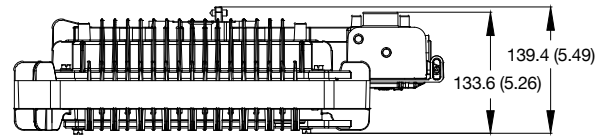

**Side View**

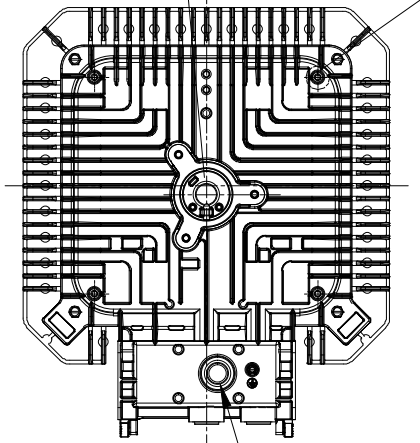
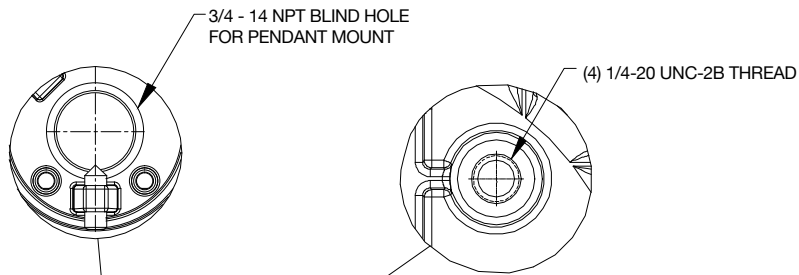

**Back View**

(1) 3/4 - 14 NPT FOR CABLE ENTRY

**BHL Models**

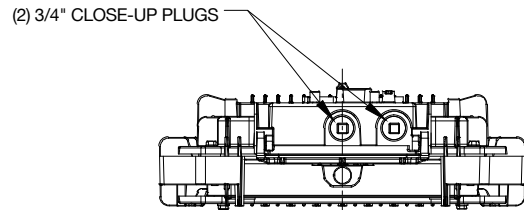

**Bottom View**

LED/HIGH BAY: NEC/CEC ENCLOSED AND GASKETED

APPLETON

# Baymaster™ and High Lumen LED Luminaire

## High Bay for Hazardous Locations

**NEC/CEC:**

Class I, Division 2, Group A, B, C, D  
 Class I, Zone 2 AEx/Ex ec Group IIC Gc  
 Class I, Zone 2, Group IIC  
 Class II, Division 1&2, Group E, F, G  
 Class III

**NEC/CEC:**

Zone 20 and 21 Group IIIC  
 Zone 21, AEx/Ex tb Group IIIC Db  
 Simultaneous Exposure  
 Marine Outside Type (Salt Water) for USA Only

**NEC/CEC:**

Wet Locations  
 Type 3R, 4 and 4X  
 IP66/67

**ATEX/IECEX:**

Zone 2 and 21  
 IP66  
 II 3G 2D  
 IK10  
 Ex ec IIC T5

**Photometric Data – DATA SHOWN IS ABSOLUTE**

Aisle, Clear Glass

REPORT NUMBER: **BLLPL6CGANBU**

Luminaire Lumens 9,679

**POLAR CANDELA DISTRIBUTION**

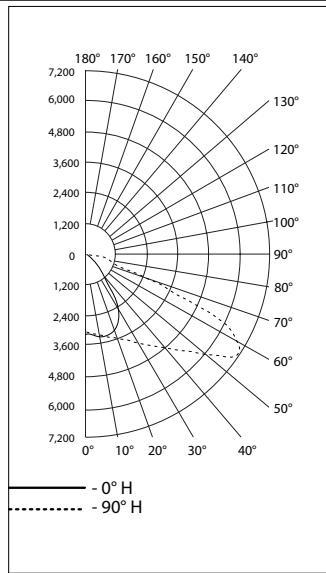

**ISOFOOT CANDLE PLOT**

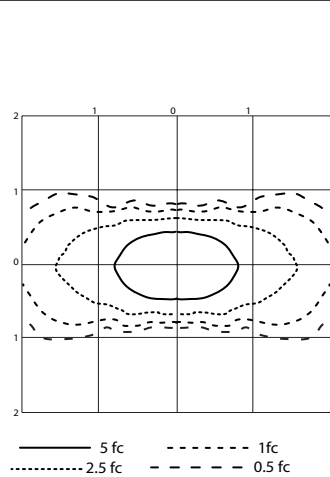

**ZONAL LUMEN SUMMARY**

Zone	Lumens	% Luminaire
0-30	2,820.3	29.1%
0-40	4,676.6	48.3%
0-60	8,307.1	85.8%
60-90	1,371.3	14.2%
70-100	171.1	1.8%
90-120	0	0%
0-90	9,678.4	100%
90-180	0	0%
0-180	9,678.4	100%

**LUMENS PER ZONE**

Zone	Lumens	% Total	Zone
0-10	306.6	3.2%	90 -100
10-20	952.6	9.8%	100 -110
20-30	1,561.2	16.1%	110 -120
30-40	1,856.2	19.2%	120 -130
40-50	1,764.9	18.2%	130 -140
50-60	1,865.7	19.3%	140 -150
60-70	1,200.2	12.4%	150 -160
70-80	159.2	1.6%	160 -170
80-90	11.9	0.1%	170 -180

Aisle, Clear Glass

REPORT NUMBER: **BLLPL6WGANBU**

Luminaire Lumens 8,432

**POLAR CANDELA DISTRIBUTION**

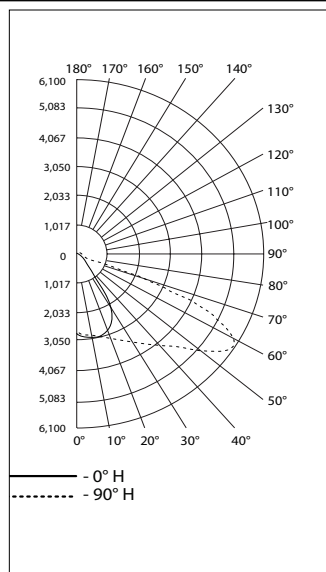

**ISOFOOT CANDLE PLOT**

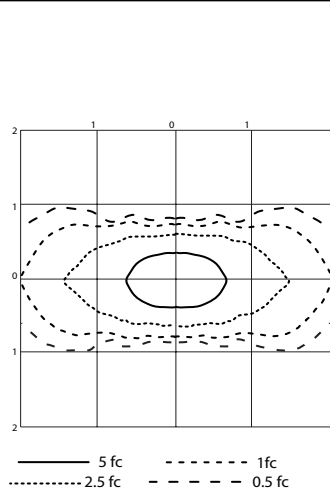

**ZONAL LUMEN SUMMARY**

Zone	Lumens	% Luminaire
0-30	2,507.0	29.7%
0-40	4,141.6	49.1%
0-60	7,265.0	86.2%
60-90	1,166.5	13.8%
70-100	139.9	1.7%
90-120	0	0%
0-90	8,431.5	100%
90-180	0	0%
0-180	8,431.5	100%

**LUMENS PER ZONE**

Zone	Lumens	% Total	Zone
0-10	275.1	3.3%	90-100
10-20	849.7	10.1%	100-110
20-30	1,382.2	16.4%	110-120
30-40	1,634.5	19.4%	120-130
40-50	1,536.3	18.2%	130-140
50-60	1,587.2	18.8%	140-150
60-70	1,026.6	12.2%	150-160
70-80	128.8	1.5%	160-170
80-90	11.1	0.1%	170-180

LED/HIGH BAY: NEC/CEC ENCLOSED AND GASKETED

APPLETON™

# Baymaster™ and High Lumen LED Luminaire

## High Bay for Hazardous Locations

**NEC/CEC:**

Class I, Division 2, Group A, B, C, D  
 Class I, Zone 2 AEx/Ex ec Group IIC Gc  
 Class I, Zone 2, Group IIC  
 Class II, Division 1&2, Group E, F, G  
 Class III

**NEC/CEC:**

Zone 20 and 21 Group IIIC  
 Zone 21, AEx/Ex tb Group IIIC Db  
 Simultaneous Exposure  
 Marine Outside Type (Salt Water) for  
 USA Only

**NEC/CEC:**

Wet Locations  
 Type 3R, 4 and 4X  
 IP66/67

**ATEX/IECEX:**

Zone 2 and 21  
 IP66  
 II 3G 2D  
 IK10  
 Ex ec IIC T5

**Photometric Data — DATA SHOWN IS ABSOLUTE**

**Aisle, Clear Glass**

REPORT NUMBER: **BLLPL7CGANBU**

Luminaire Lumens 15,234

**POLAR CANDELA DISTRIBUTION**

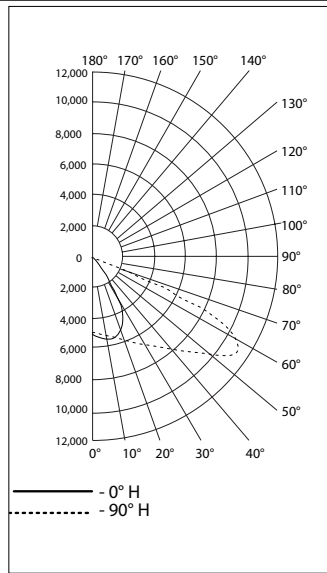

**ISOFOOT CANDLE PLOT**

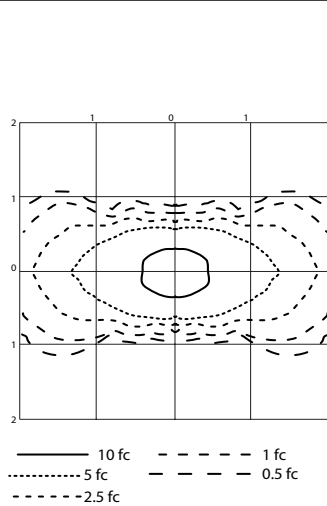

**ZONAL LUMEN SUMMARY**

Zone	Lumens	% Luminaire
0-30	4,456.3	29.3%
0-40	7,383.0	48.5%
0-60	13,097.7	86%
60-90	2,136.1	14%
70-100	262.4	1.7%
90-120	0	0%
0-90	15,233.8	100%
90-180	0	0%
0-180	15,233.8	100%

**LUMENS PER ZONE**

Zone	Lumens	% Total	Zone
0-10	484.8	3.2%	90-100
10-20	1,506.6	9.9%	100-110
20-30	2,464.8	16.2%	110-120
30-40	2,926.7	19.2%	120-130
40-50	2,779.6	18.2%	130-140
50-60	2,935.1	19.3%	140-150
60-70	1,873.7	12.3%	150-160
70-80	243.9	1.6%	160-170
80-90	18.5	0.1%	170-180

**Aisle, Clear Glass**

REPORT NUMBER: **BLLPL7WGANBU**

Luminaire Lumens 12,579

**POLAR CANDELA DISTRIBUTION**

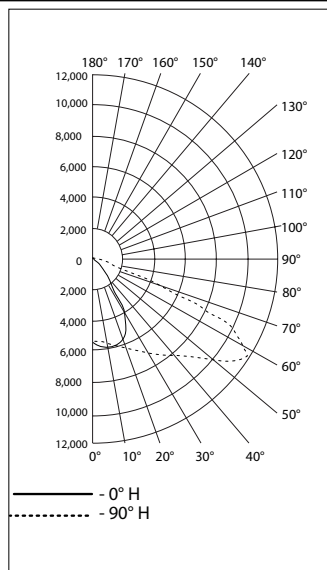

**ISOFOOT CANDLE PLOT**

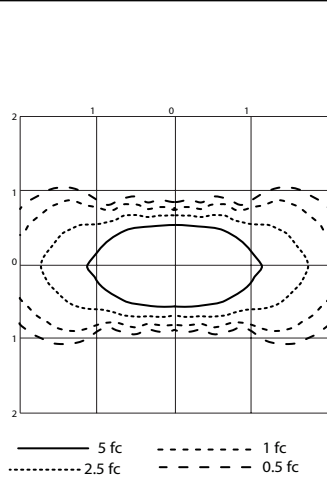

**ZONAL LUMEN SUMMARY**

Zone	Lumens	% Luminaire
0-30	3,750.7	29.8%
0-40	6,191.4	49.2%
0-60	10,866.4	86.4%
60-90	1,711.8	13.6%
70-100	199.6	1.6%
90-120	0	0%
0-90	12,578.2	100%
90-180	0	0%
0-180	12,578.2	100%

**LUMENS PER ZONE**

Zone	Lumens	% Total	Zone
0-10	412.0	3.3%	90-100
10-20	1,272.1	10.1%	100-110
20-30	2,066.7	16.4%	110-120
30-40	2,440.6	19.4%	120-130
40-50	2,296.4	18.3%	130-140
50-60	2,378.7	18.9%	140-150
60-70	1,512.1	12.0%	150-160
70-80	183.7	1.5%	160-170
80-90	15.9	0.1%	170-180

# Baymaster™ and High Lumen LED Luminaire

## High Bay for Hazardous Locations

**NEC/CEC:**

Class I, Division 2, Group A, B, C, D  
 Class I, Zone 2 AEx/Ex ec Group IIC Gc  
 Class I, Zone 2, Group IIC  
 Class II, Division 1&2, Group E, F, G  
 Class III

**NEC/CEC:**

Zone 20 and 21 Group IIIC  
 Zone 21, AEx/Ex tb Group IIIC Db  
 Simultaneous Exposure  
 Marine Outside Type (Salt Water) for USA Only

**NEC/CEC:**

Wet Locations  
 Type 3R, 4 and 4X  
 IP66/67

**ATEX/IECEX:**

Zone 2 and 21  
 IP66  
 II 3G 2D  
 IK10  
 Ex ec IIC T5

**Photometric Data – DATA SHOWN IS ABSOLUTE**

Aisle, Clear Glass

REPORT NUMBER: **BLLPL8CGANBU**

Luminaire Lumens 19,774

**POLAR CANDELA DISTRIBUTION**

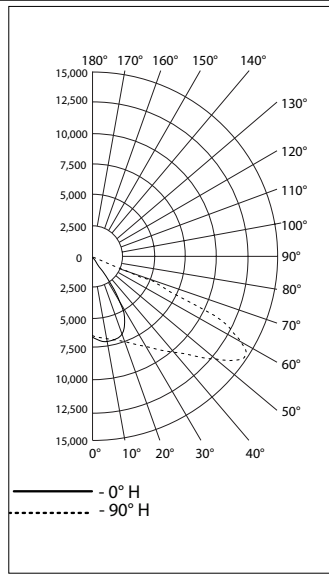

**ISOFOOT CANDLE PLOT**

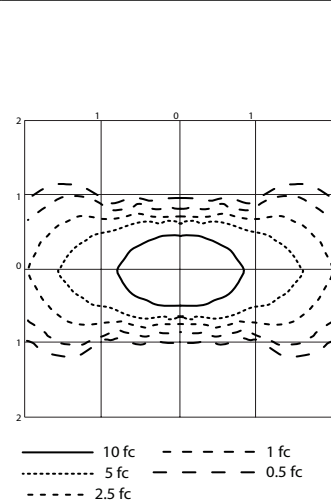

**FLOOD SUMMARY**

Zone	Lumens	% Luminaire
0-30	5,782.9	29.2%
0-40	9,577.4	48.4%
0-60	17,028.6	86.1%
60-90	2,744.6	13.9%
70-100	335.8	1.7%
90-120	0	0%
0-90	19,773.2	100%
90-180	0	0%
0-180	19,773.2	100%

**LUMENS PER ZONE**

Zone	Lumens	% Total	Zone
0-10	629.4	3.2%	90-100
10-20	1,956.0	9.9%	100-110
20-30	3,197.4	16.2%	110-120
30-40	3,794.6	19.2%	120-130
40-50	3,616.6	18.3%	130-140
50-60	3,834.5	19.4%	140-150
60-70	2,408.8	12.2%	150-160
70-80	310.4	1.6%	160-170
80-90	25.4	0.1%	170-180

Aisle, Clear Glass

REPORT NUMBER: **BLLPL8WGANBU**

Luminaire Lumens 16,350

**POLAR CANDELA DISTRIBUTION**

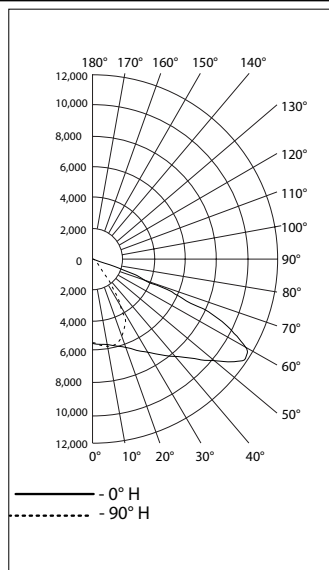

**ISOFOOT CANDLE PLOT**

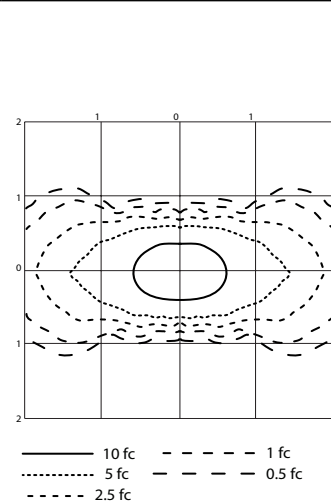

**ZONAL LUMEN SUMMARY**

Zone	Lumens	% Luminaire
0-30	4,884.8	29.9%
0-40	8,058.6	49.3%
0-60	14,153.0	86.6%
60-90	2,196.0	13.4%
70-100	253.6	1.6%
90-120	0	0%
0-90	16,349.0	100%
90-180	0	0%
0-180	16,349.0	100%

**LUMENS PER ZONE**

Zone	Lumens	% Total	Zone
0-10	536.5	3.3%	90-100
10-20	1,657.0	10.1%	100-110
20-30	2,691.4	16.5%	110-120
30-40	3,173.7	19.4%	120-130
40-50	2,984.8	18.3%	130-140
50-60	3,109.6	19.0%	140-150
60-70	1,942.4	11.9%	150-160
70-80	232.7	1.4%	160-170
80-90	20.8	0.1%	170-180

LED/HIGH BAY- NEC/CEC ENCLOSED AND GASKETED

APPLETON™

# Baymaster™ and High Lumen LED Luminaire

## High Bay for Hazardous Locations

**NEC/CEC:**

Class I, Division 2, Group A, B, C, D  
 Class I, Zone 2 AEx/Ex ec Group IIC Gc  
 Class I, Zone 2, Group IIC  
 Class II, Division 1&2, Group E, F, G  
 Class III

**NEC/CEC:**

Zone 20 and 21 Group IIIC  
 Zone 21, AEx/Ex tb Group IIIC Db  
 Simultaneous Exposure  
 Marine Outside Type (Salt Water) for  
 USA Only

**NEC/CEC:**

Wet Locations  
 Type 3R, 4 and 4X  
 IP66/67

**ATEX/IECEX:**

Zone 2 and 21  
 IP66  
 II 3G 2D  
 IK10  
 Ex ec IIC T5

**Photometric Data — DATA SHOWN IS ABSOLUTE**

**Type V Wide, Clear Glass**

REPORT NUMBER: **BLLPL6CGWNB**

Luminaire Lumens 8,682

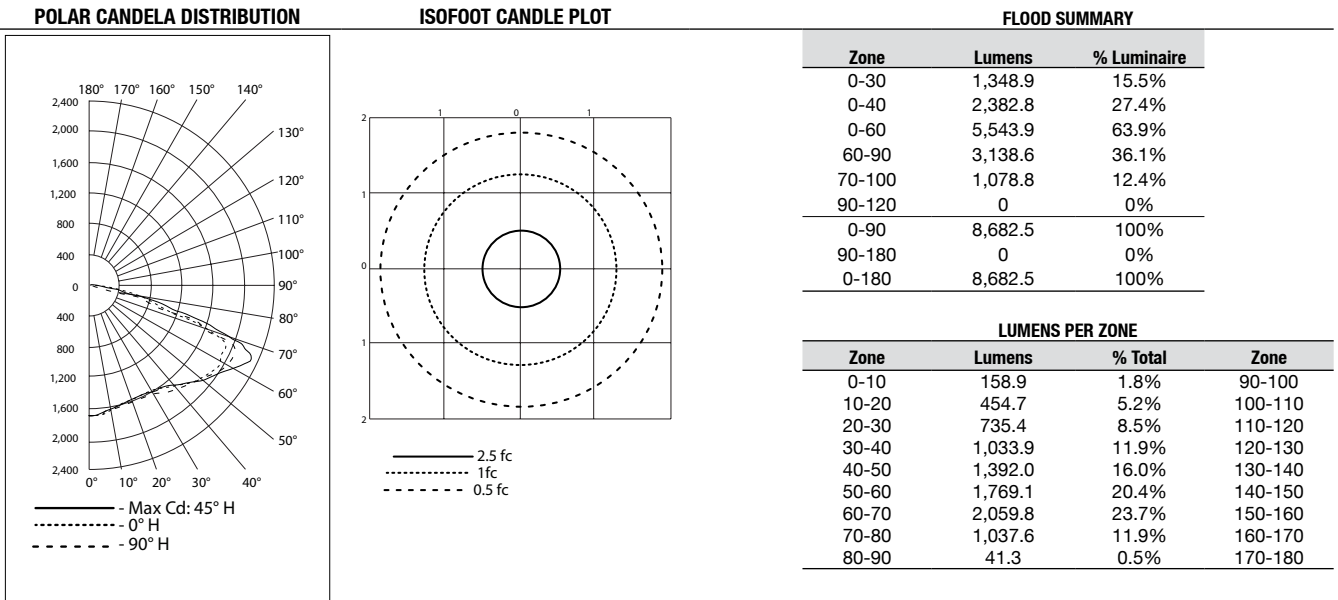

**Type V Wide, Clear Glass**

REPORT NUMBER: **BLLPI6GWNB**

Luminaire Lumens 7,506

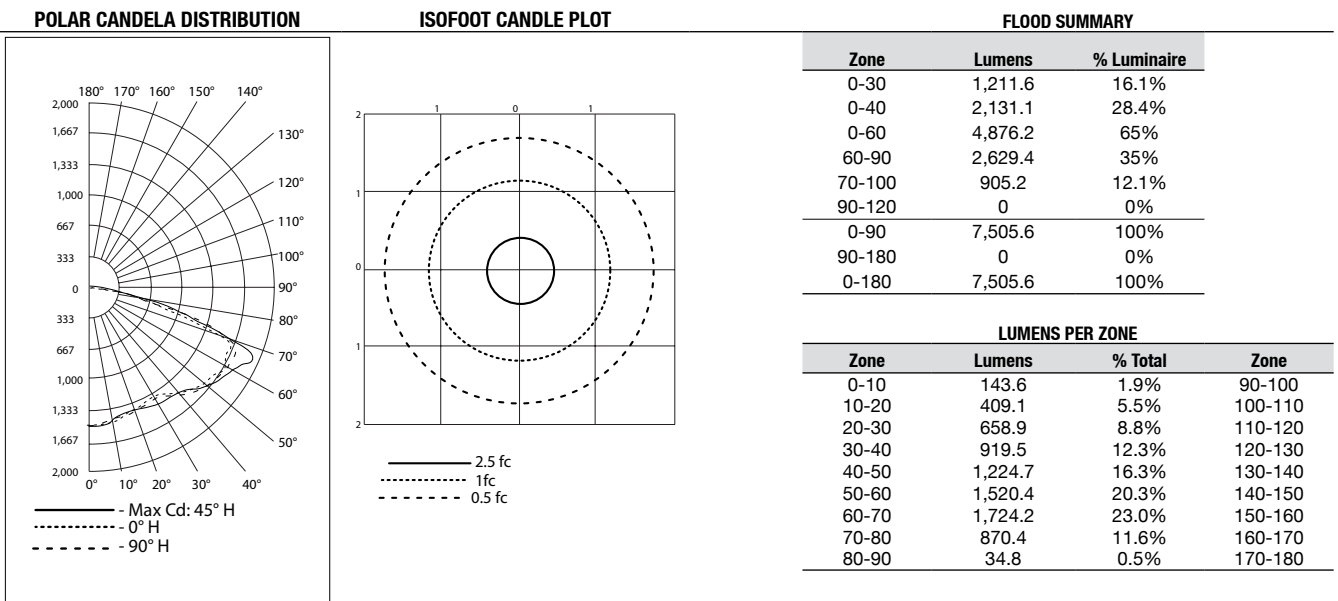

# Baymaster™ and High Lumen LED Luminaire

## High Bay for Hazardous Locations

**NEC/CEC:**  
 Class I, Division 2, Group A, B, C, D  
 Class I, Zone 2 AEx/Ex ec Group IIC Gc  
 Class I, Zone 2, Group IIC  
 Class II, Division 1&2, Group E, F, G  
 Class III

**NEC/CEC:**  
 Zone 20 and 21 Group IIIC  
 Zone 21, AEx/Ex tb Group IIIC Db  
 Simultaneous Exposure  
 Marine Outside Type (Salt Water) for  
 USA Only

**NEC/CEC:**  
 Wet Locations  
 Type 3R, 4 and 4X  
 IP66/67

**ATEX/IECEX:**  
 Zone 2 and 21  
 IP66  
 II 3G 2D  
 IK10  
 Ex ec IIC T5

### Photometric Data – DATA SHOWN IS ABSOLUTE

Type V Wide, Clear Glass

REPORT NUMBER: **BLLPL7CGWNBU**

Luminaire Lumens 13,608

#### POLAR CANDELA DISTRIBUTION

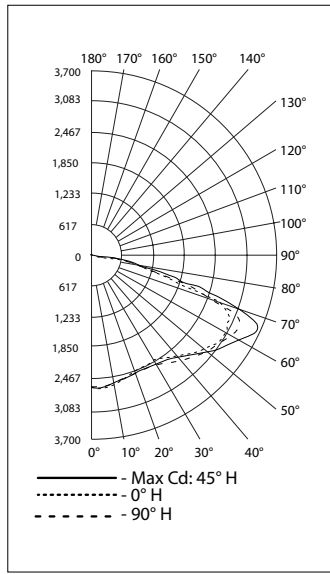

#### ISOFOOT CANDLE PLOT

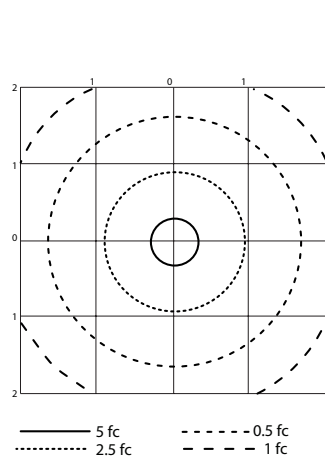

#### FLOOD SUMMARY

Zone	Lumens	% Luminaire
0-30	2,119.5	15.6%
0-40	3,743.3	27.5%
0-60	8,711.1	64%
60-90	4,897.4	36%
70-100	1,668.8	12.3%
90-120	0	0%
0-90	13,608.5	100%
90-180	0	0%
0-180	13,608.5	100%

#### LUMENS PER ZONE

Zone	Lumens	% Total	Zone
0-10	249.6	1.8%	90-100
10-20	714.5	5.3%	100-110
20-30	1,155.4	8.5%	110-120
30-40	1,623.7	11.9%	120-130
40-50	2,188.0	16.1%	130-140
50-60	2,779.9	20.4%	140-150
60-70	3,228.7	23.7%	150-160
70-80	1,606.3	11.8%	160-170
80-90	62.4	0.5%	170-180

Type V Wide, Clear Glass

REPORT NUMBER: **BLLPI7WGWNU**

Luminaire Lumens 11,351

#### POLAR CANDELA DISTRIBUTION

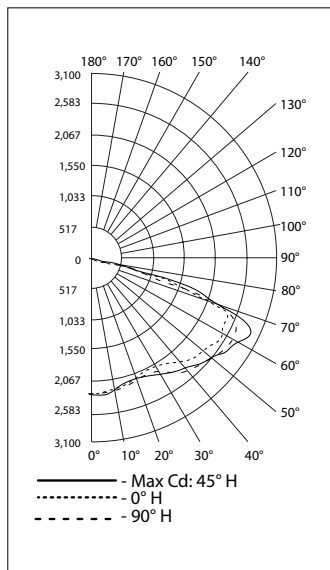

#### ISOFOOT CANDLE PLOT

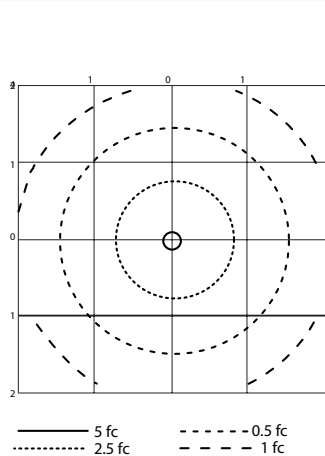

#### FLOOD SUMMARY

Zone	Lumens	% Luminaire
0-30	1,832.3	16.1%
0-40	3,226.8	28.4%
0-60	7,385.1	65.1%
60-90	3,965.6	34.9%
70-100	1,355.2	11.9%
90-120	0	0%
0-90	11,350.7	100%
90-180	0	0%
0-180	11,350.7	100%

#### LUMENS PER ZONE

Zone	Lumens	% Total	Zone
0-10	216.7	1.9%	90-100
10-20	618.0	5.4%	100-110
20-30	997.6	8.8%	110-120
30-40	1,394.6	12.3%	120-130
40-50	1,855.9	16.4%	130-140
50-60	2,302.3	20.3%	140-150
60-70	2,610.5	23.0%	150-160
70-80	1,305.4	11.5%	160-170
80-90	49.8	0.4%	170-180

LED/HIGH BAY: NEC/CEC ENCLOSED AND GASKETED

APPLETON™

# Baymaster™ and High Lumen LED Luminaire

## High Bay for Hazardous Locations

**NEC/CEC:**

Class I, Division 2, Group A, B, C, D  
 Class I, Zone 2 AEx/Ex ec Group IIC Gc  
 Class I, Zone 2, Group IIC  
 Class II, Division 1&2, Group E, F, G  
 Class III

**NEC/CEC:**

Zone 20 and 21 Group IIIC  
 Zone 21, AEx/Ex tb Group IIIC Db  
 Simultaneous Exposure  
 Marine Outside Type (Salt Water) for  
 USA Only

**NEC/CEC:**

Wet Locations  
 Type 3R, 4 and 4X  
 IP66/67

**ATEX/IECEX:**

Zone 2 and 21  
 IP66  
 II 3G 2D  
 IK10  
 Ex ec IIC T5

**Photometric Data – DATA SHOWN IS ABSOLUTE**

**Type V Wide, Clear Glass**

REPORT NUMBER: **BLLPL8CGWNB**

Luminaire Lumens 17,710

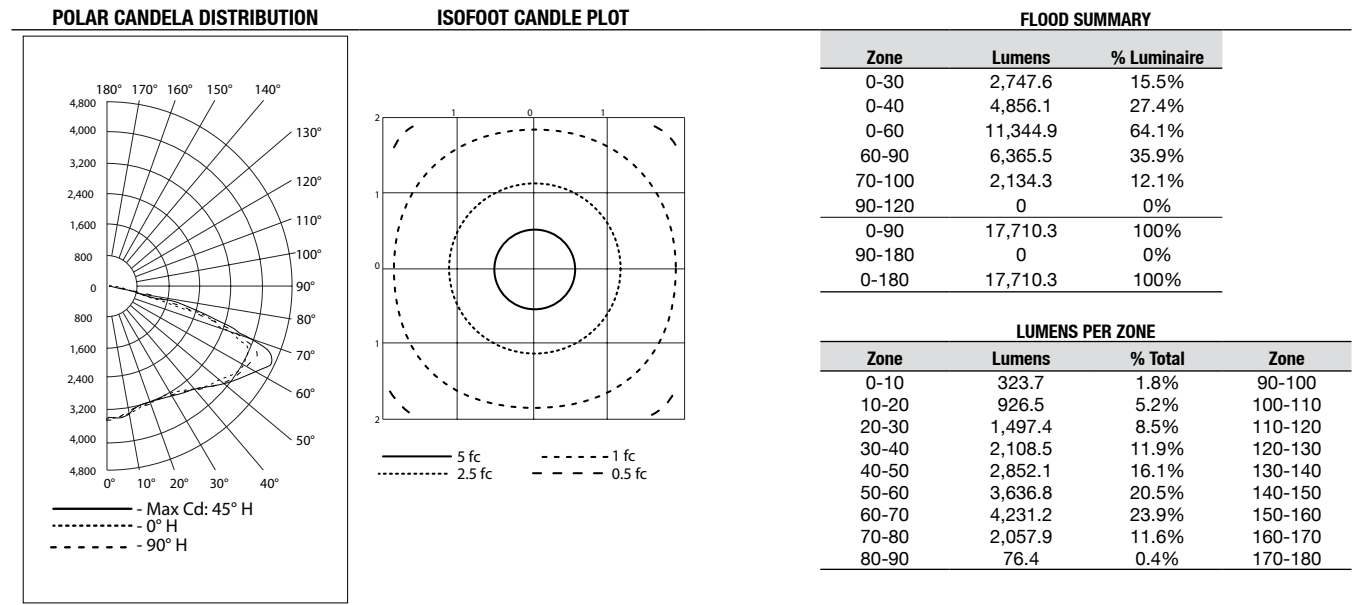

**Type V Wide, Clear Glass**

REPORT NUMBER: **BLLPL8WGWNB**

Luminaire Lumens 14,676

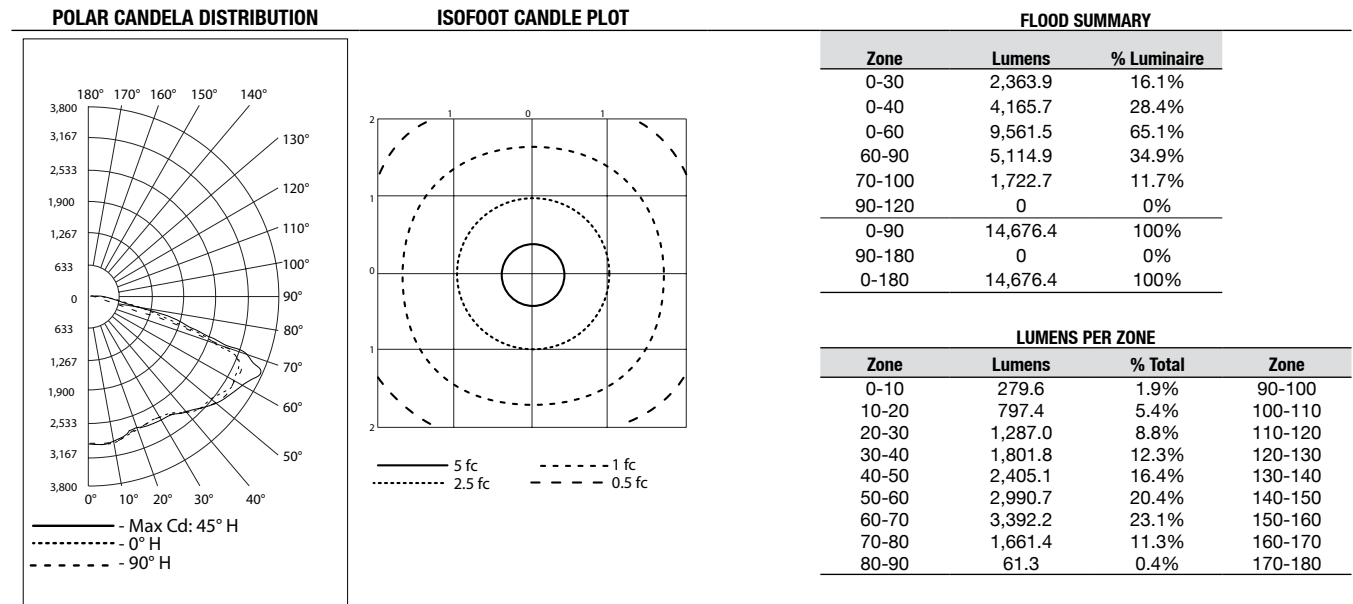

# Baymaster™ and High Lumen LED Luminaire

## High Bay for Hazardous Locations

**NEC/CEC:**  
 Class I, Division 2, Group A, B, C, D  
 Class I, Zone 2 AEx/Ex ec Group IIC Gc  
 Class I, Zone 2, Group IIC  
 Class II, Division 1&2, Group E, F, G  
 Class III

**NEC/CEC:**  
 Zone 20 and 21 Group IIIC  
 Zone 21, AEx/Ex tb Group IIIC Db  
 Simultaneous Exposure  
 Marine Outside Type (Salt Water) for  
 USA Only

**NEC/CEC:**  
 Wet Locations  
 Type 3R, 4 and 4X  
 IP66/67

**ATEX/IECEX:**  
 Zone 2 and 21  
 IP66  
 II 3G 2D  
 IK10  
 Ex ec IIC T5

### Photometric Data – DATA SHOWN IS ABSOLUTE

Type V, Clear Glass

REPORT NUMBER: **BLLPL6CGMNB**

Luminaire Lumens 9,758

#### POLAR CANDELA DISTRIBUTION

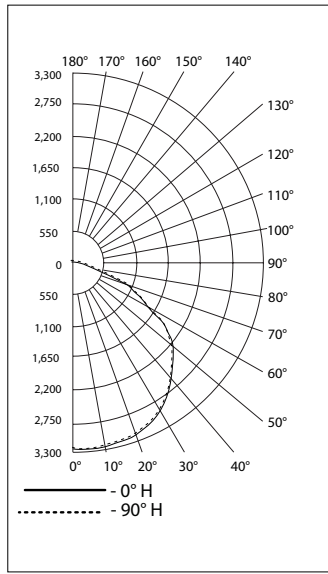

#### ISOFOOT CANDLE PLOT

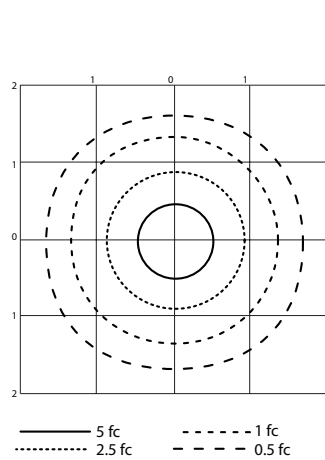

#### FLOOD SUMMARY

Zone	Lumens	% Luminaire
0-30	2,652.8	27.2%
0-40	4,452.5	45.6%
0-60	8,136.0	83.4%
60-90	1,621.4	16.6%
70-100	448.1	4.6%
90-120	0	0%
0-90	9,757.4	100%
90-180	0	0%
0-180	9,757.4	100%

#### LUMENS PER ZONE

Zone	Lumens	% Total	Zone
0-10	308.6	3.2%	90-100
10-20	909.9	9.3%	100-110
20-30	1,434.3	14.7%	110-120
30-40	1,799.7	18.4%	120-130
40-50	1,932.1	19.8%	130-140
50-60	1,751.4	17.9%	140-150
60-70	1,173.3	12.0%	150-160
70-80	416.4	4.3%	160-170
80-90	31.7	0.3%	170-180

Type V, Clear Glass

REPORT NUMBER: **BLLPL7CGMNB**

Luminaire Lumens 15,392

#### POLAR CANDELA DISTRIBUTION

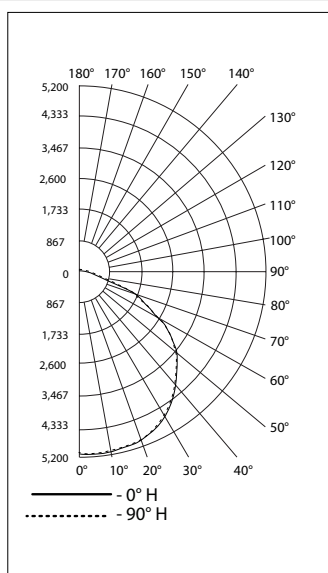

#### ISOFOOT CANDLE PLOT

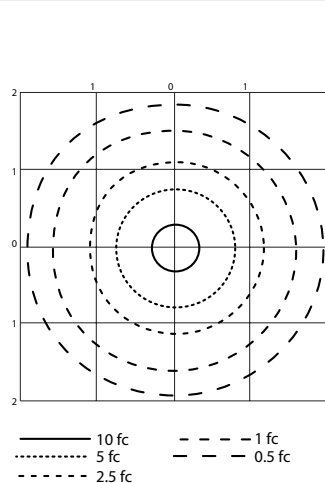

#### FLOOD SUMMARY

Zone	Lumens	% Luminaire
0-30	4,187.7	27.2%
0-40	7,034.1	45.7%
0-60	12,847.0	83.5%
60-90	2,544.4	16.5%
70-100	704.8	4.6%
90-120	0	0%
0-90	15,391.4	100%
90-180	0	0%
0-180	15,391.4	100%

#### LUMENS PER ZONE

Zone	Lumens	% Total	Zone
0-10	486.6	3.2%	90-100
10-20	1,435.2	9.3%	100-110
20-30	2,265.9	14.7%	110-120
30-40	2,846.4	18.5%	120-130
40-50	3,051.4	19.8%	130-140
50-60	2,761.4	17.9%	140-150
60-70	1,839.6	12.0%	150-160
70-80	655.0	4.3%	160-170
80-90	49.8	0.3%	170-180

LED/HIGH BAY: NEC/CEC ENCLOSED AND GASKETED

APPLETON™



# Baymaster™ and High Lumen LED Luminaire

## High Bay for Hazardous Locations

**NEC/CEC:**

Class I, Division 2, Group A, B, C, D  
 Class I, Zone 2 AEx/Ex ec Group IIC Gc  
 Class I, Zone 2, Group IIC  
 Class II, Division 1&2, Group E, F, G  
 Class III

**NEC/CEC:**

Zone 20 and 21 Group IIIC  
 Zone 21, AEx/Ex tb Group IIIC Db  
 Simultaneous Exposure  
 Marine Outside Type (Salt Water) for  
 USA Only

**NEC/CEC:**

Wet Locations  
 Type 3R, 4 and 4X  
 IP66/67

**ATEX/IECEX:**

Zone 2 and 21  
 IP66  
 II 3G 2D  
 IK10  
 Ex ec IIC T5

**Photometric Data – DATA SHOWN IS ABSOLUTE**

**Type V, Clear Glass**

REPORT NUMBER: **BLLPL8CGMNB**

Luminaire Lumens 20,097

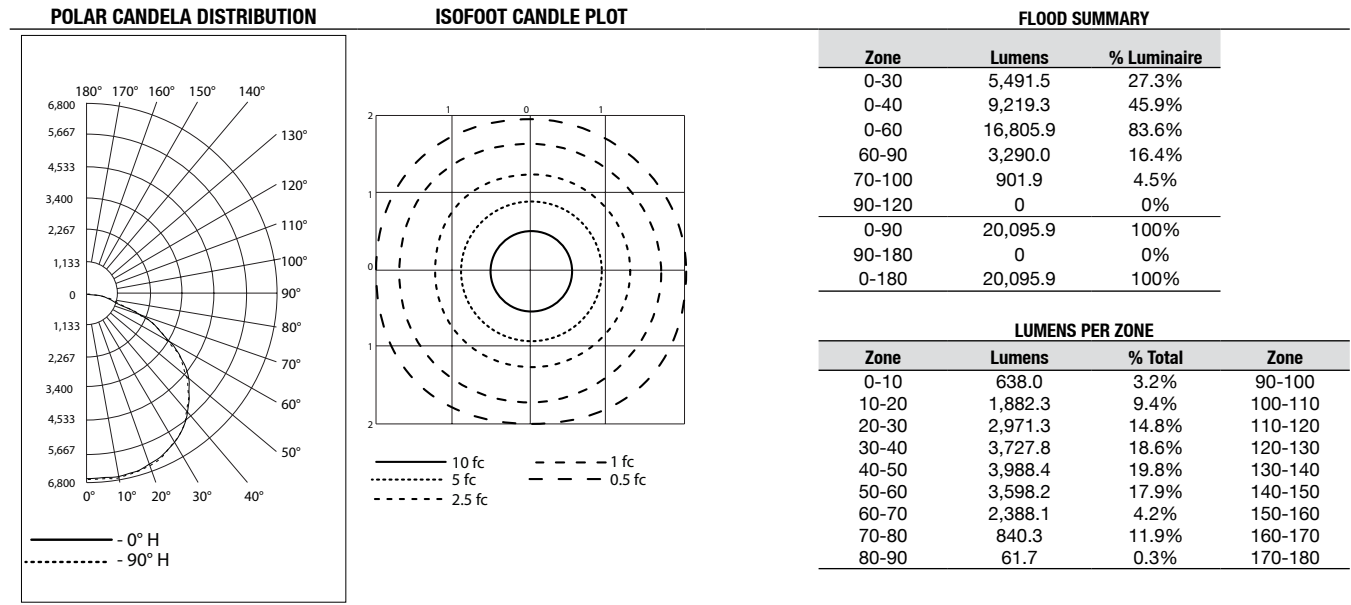

**Type V, Frosted Glass**

REPORT NUMBER: **BLLPL6CFMNB**

Luminaire Lumens 8,209

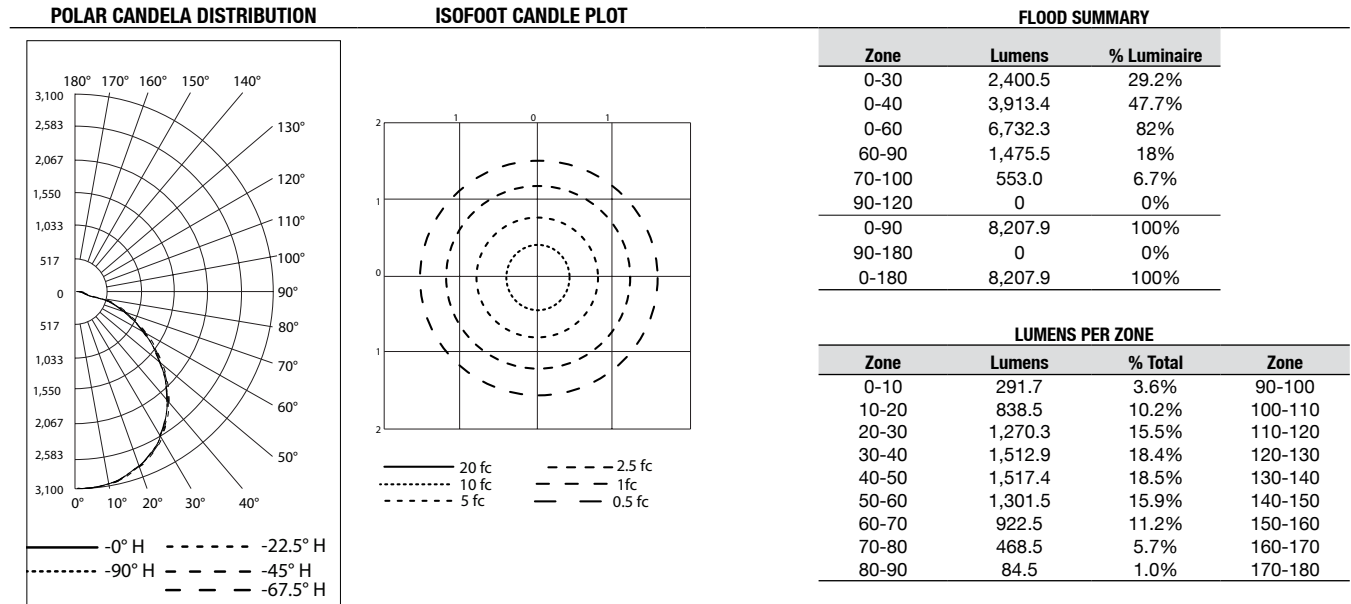

# Baymaster™ and High Lumen LED Luminaire

## High Bay for Hazardous Locations

**NEC/CEC:**

Class I, Division 2, Group A, B, C, D  
 Class I, Zone 2 AEx/Ex ec Group IIC Gc  
 Class I, Zone 2, Group IIC  
 Class II, Division 1&2, Group E, F, G  
 Class III

**NEC/CEC:**

Zone 20 and 21 Group IIIC  
 Zone 21, AEx/Ex tb Group IIIC Db  
 Simultaneous Exposure  
 Marine Outside Type (Salt Water) for USA Only

**NEC/CEC:**

Wet Locations  
 Type 3R, 4 and 4X  
 IP66/67

**ATEX/IECEX:**

Zone 2 and 21  
 IP66  
 II 3G 2D  
 IK10  
 Ex ec IIC T5

**Photometric Data – DATA SHOWN IS ABSOLUTE**

**Type V, Frosted Glass**

REPORT NUMBER: **BLLPL7CFMNB**

Luminaire Lumens 12,955

**POLAR CANDELA DISTRIBUTION**

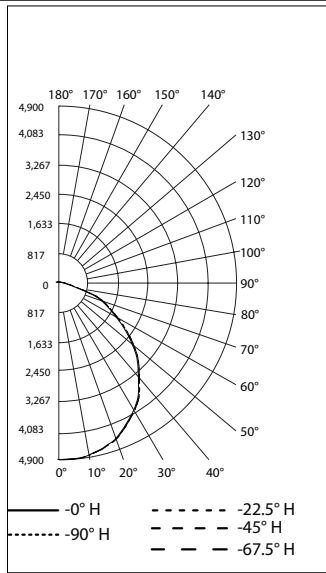

**ISOFOOT CANDLE PLOT**

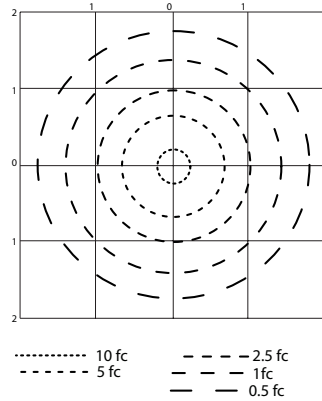

..... 10 fc      - - - - 2.5 fc  
 - - - - 5 fc      - - - - 1 fc  
 - - - - 0.5 fc

**FLOOD SUMMARY**

Zone	Lumens	% Luminaire
0-30	3,794.5	29.3%
0-40	6,181.5	47.7%
0-60	10,623.4	82%
60-90	2,330.5	18%
70-100	875.2	6.8%
90-120	0	0%
0-90	12,953.9	100%
90-180	0	0%
0-180	12,953.9	100%

**LUMENS PER ZONE**

Zone	Lumens	% Total	Zone
0-10	461.3	3.6%	90-100
10-20	1,326.2	10.2%	100-110
20-30	2,007.0	15.5%	110-120
30-40	2,387.0	18.4%	120-130
40-50	2,392.1	18.5%	130-140
50-60	2,049.8	15.8%	140-150
60-70	1,455.3	11.2%	150-160
70-80	740.7	5.7%	160-170
80-90	134.5	1.0%	170-180

**Type V, Clear Glass**

REPORT NUMBER: **BLLPL8CFMNB**

Luminaire Lumens 16,711

**POLAR CANDELA DISTRIBUTION**

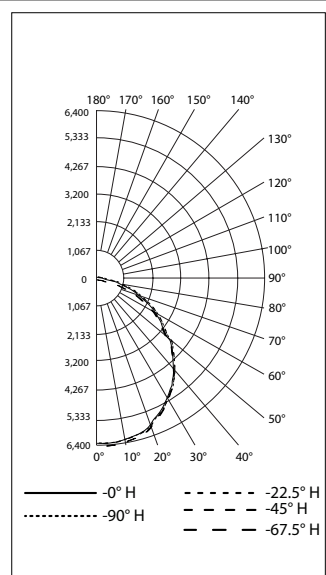

**ISOFOOT CANDLE PLOT**

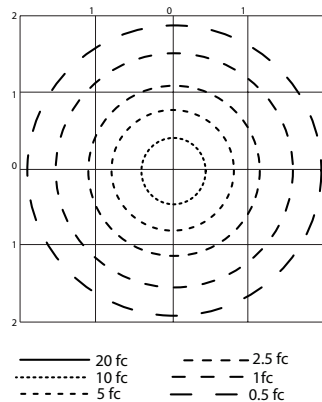

..... 20 fc      - - - - 2.5 fc  
 - - - - 10 fc      - - - - 1 fc  
 - - - - 5 fc      - - - - 0.5 fc

**FLOOD SUMMARY**

Zone	Lumens	% Luminaire
0-30	4,907.8	29.4%
0-40	7,989.9	47.8%
0-60	13,718.2	82.1%
60-90	2,991.4	17.9%
70-100	1,120.8	6.7%
90-120	0	0%
0-90	16,709.6	100%
90-180	0	0%
0-180	16,709.6	100%

**LUMENS PER ZONE**

Zone	Lumens	% Total	Zone
0-10	597.1	3.6%	90-100
10-20	1,715.9	10.3%	100-110
20-30	2,594.8	15.5%	110-120
30-40	3,082.1	18.4%	120-130
40-50	3,086.8	18.5%	130-140
50-60	2,641.5	15.8%	140-150
60-70	1,870.6	11.2%	150-160
70-80	949.8	5.7%	160-170
80-90	171.0	1.0%	170-180

LED/HIGH BAY- NEC/CEC ENCLOSED AND GASKETED

APPLETON™

# Baymaster™ and High Lumen LED Luminaire

## High Bay for Hazardous Locations

**NEC/CEC:**

Class I, Division 2, Group A, B, C, D  
 Class I, Zone 2 AEx/Ex ec Group IIC Gc  
 Class I, Zone 2, Group IIC  
 Class II, Division 1&2, Group E, F, G  
 Class III

**NEC/CEC:**

Zone 20 and 21 Group IIIC  
 Zone 21, AEx/Ex tb Group IIIC Db  
 Simultaneous Exposure  
 Marine Outside Type (Salt Water) for  
 USA Only

**NEC/CEC:**

Wet Locations  
 Type 3R, 4 and 4X  
 IP66/67

**ATEX/IECEX:**

Zone 2 and 21  
 IP66  
 II 3G 2D  
 IK10  
 Ex ec IIC T5

**Photometric Data – DATA SHOWN IS ABSOLUTE**

**Type V Narrow, Clear Glass 5000K CCT**

REPORT NUMBER: **BHLPL1CGNNBU**

Luminaire Lumens 24,459

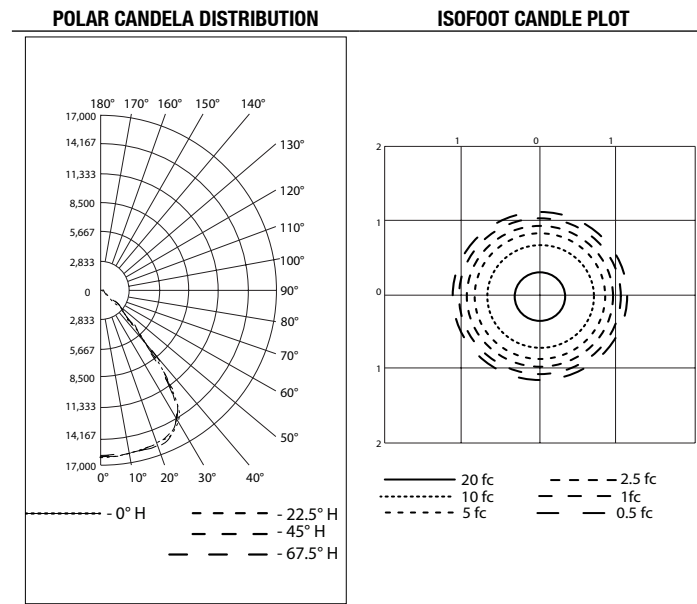

**ZONAL LUMEN SUMMARY**

Zone	Lumens	% Luminaire
0-30	13,267.9	54.3%
0-40	20,732.9	84.8%
0-60	23,891.8	97.7%
60-90	561.6	2.3%
70-100	242.1	1%
90-120	0	0%
0-90	24,453.4	100%
90-180	0	0%
0-180	24,453.4	100%

**LUMENS PER ZONE**

Zone	Lumens	% Total	Zone
0-10	1,538.5	6.3%	90-100
10-20	4,553.8	18.6%	100-110
20-30	7,175.6	29.3%	110-120
30-40	7,465.0	30.5%	120-130
40-50	2,717.0	11.1%	130-140
50-60	441.9	1.8%	140-150
60-70	319.5	1.3%	150-160
70-80	215.3	0.9%	160-170
80-90	26.8	0.1%	170-180

**Type V Narrow, Clear Glass 3000K CCT**

REPORT NUMBER: **BHLPL1WGNNBU**

Luminaire Lumens 21,648

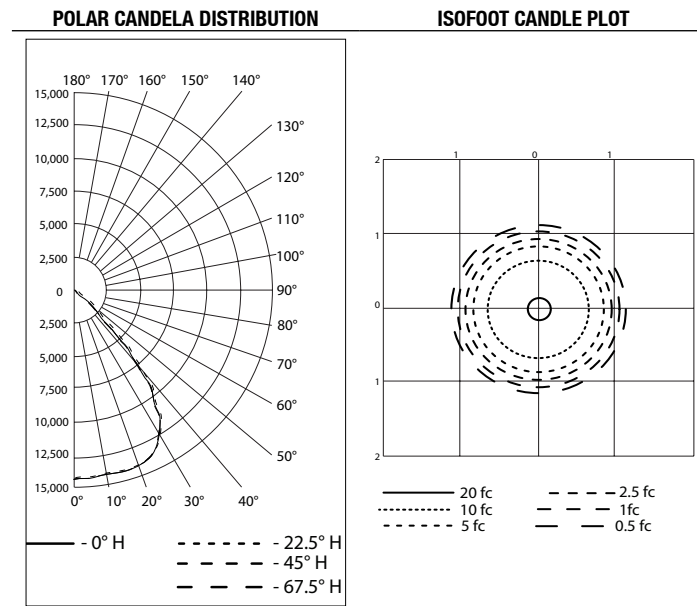

**ZONAL LUMEN SUMMARY**

Zone	Lumens	% Luminaire
0-30	11,658.8	53.9%
0-40	18,259.6	84.4%
0-60	21,173.3	97.8%
60-90	469.0	2.2%
70-100	195.8	0.9%
90-120	0	0%
0-90	21,642.2	100%
90-180	0	0%
0-180	21,642.2	100%

**LUMENS PER ZONE**

Zone	Lumens	% Total	Zone
0-10	1,538.5	6.3%	90-100
10-20	4,553.8	18.6%	100-110
20-30	7,175.6	29.3%	110-120
30-40	7,465.0	30.5%	120-130
40-50	2,717.0	11.1%	130-140
50-60	441.9	1.8%	140-150
60-70	319.5	1.3%	150-160
70-80	215.3	0.9%	160-170
80-90	26.8	0.1%	170-180

# Baymaster™ and High Lumen LED Luminaire

## High Bay for Hazardous Locations

**NEC/CEC:**

Class I, Division 2, Group A, B, C, D  
 Class I, Zone 2 AEx/Ex ec Group IIC Gc  
 Class I, Zone 2, Group IIC  
 Class II, Division 1&2, Group E, F, G  
 Class III

**NEC/CEC:**

Zone 20 and 21 Group IIIC  
 Zone 21, AEx/Ex tb Group IIIC Db  
 Simultaneous Exposure  
 Marine Outside Type (Salt Water) for  
 USA Only

**NEC/CEC:**

Wet Locations  
 Type 3R, 4 and 4X  
 IP66/67

**ATEX/IECEX:**

Zone 2 and 21  
 IP66  
 II 3G 2D  
 IK10  
 Ex ec IIC T5

**Photometric Data — DATA SHOWN IS ABSOLUTE**

**Type V Narrow, Clear Glass 5000K CCT**

REPORT NUMBER: **BHLPL2CGNNBU**

Luminaire Lumens 30,396

**POLAR CANDELA DISTRIBUTION**

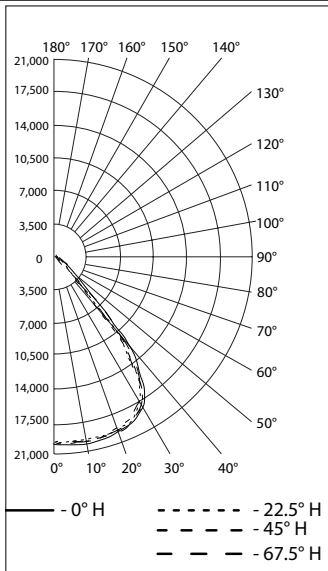

**ISOFOOT CANDLE PLOT**

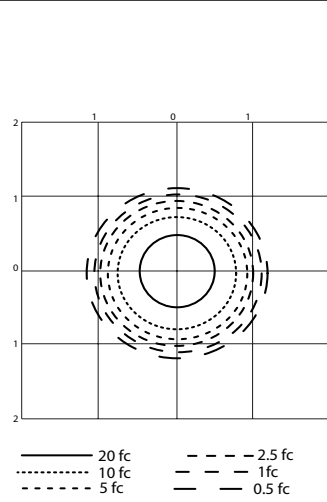

**ZONAL LUMEN SUMMARY**

Zone	Lumens	% Luminaire
0-30	16,453.1	54.1%
0-40	25,742.1	84.7%
0-60	29,699.7	97.7%
60-90	688.8	2.3%
70-100	296.7	1%
90-120	0	0%
0-90	30,388.4	100%
90-180	0	0%
0-180	30,388.4	100%

**LUMENS PER ZONE**

Zone	Lumens	% Total	Zone
0-10	1,909.5	6.3%	90-100
10-20	5,644.4	18.6%	100-110
20-30	8,899.2	29.3%	110-120
30-40	9,289.1	30.6%	120-130
40-50	3,411.2	11.2%	130-140
50-60	546.3	1.8%	140-150
60-70	392.0	1.3%	150-160
70-80	263.9	0.9%	160-170
80-90	32.9	0.1%	170-180

**Type V Narrow, Clear Glass 3000K CCT**

REPORT NUMBER: **BHLPL2WGNNBU**

Luminaire Lumens 25,785

**POLAR CANDELA DISTRIBUTION**

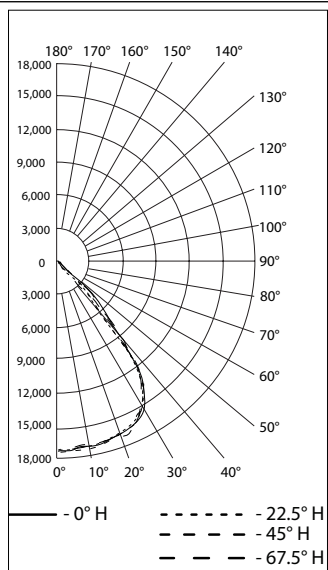

**ISOFOOT CANDLE PLOT**

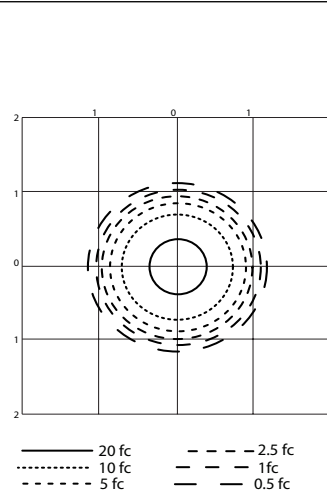

**ZONAL LUMEN SUMMARY**

Zone	Lumens	% Luminaire
0-30	13,938.3	54.1%
0-40	21,797.3	84.6%
0-60	25,219.8	97.8%
60-90	559.0	2.2%
70-100	234.4	0.9%
90-120	0	0%
0-90	25,778.8	100%
90-180	0	0%
0-180	25,778.8	100%

**LUMENS PER ZONE**

Zone	Lumens	% Total	Zone
0-10	1,633.4	6.3%	90-100
10-20	4,795.3	18.6%	100-110
20-30	7,509.5	29.1%	110-120
30-40	7,859.0	30.5%	120-130
40-50	2,974.1	11.5%	130-140
50-60	448.4	1.7%	140-150
60-70	324.5	1.3%	150-160
70-80	208.1	0.8%	160-170
80-90	26.3	0.1%	170-180

LED/HIGH BAY: NEC/CEC ENCLOSED AND GASKETED

APPLETON™

# Baymaster™ and High Lumen LED Luminaire

## High Bay for Hazardous Locations

**NEC/CEC:**

Class I, Division 2, Group A, B, C, D  
 Class I, Zone 2 AEx/Ex ec Group IIC Gc  
 Class I, Zone 2, Group IIC  
 Class II, Division 1&2, Group E, F, G  
 Class III

**NEC/CEC:**

Zone 20 and 21 Group IIIC  
 Zone 21, AEx/Ex tb Group IIIC Db  
 Simultaneous Exposure  
 Marine Outside Type (Salt Water) for  
 USA Only

**NEC/CEC:**

Wet Locations  
 Type 3R, 4 and 4X  
 IP66/67

**ATEX/IECEX:**

Zone 2 and 21  
 IP66  
 II 3G 2D  
 IK10  
 Ex ec IIC T5

**Photometric Data – DATA SHOWN IS ABSOLUTE**

**Type V Narrow, Clear Glass 5000K CCT**

REPORT NUMBER: BHLPL3CGNNBU

Luminaire Lumens 39,041

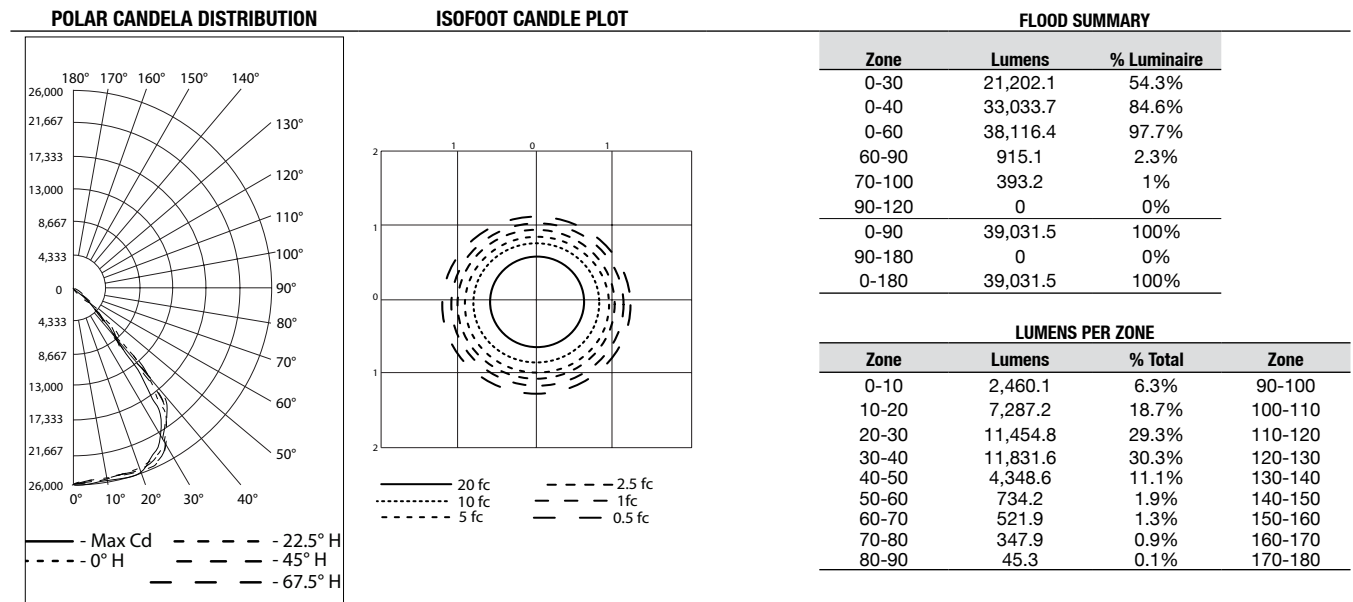

**Type V Narrow, Clear Glass 3000K CCT**

REPORT NUMBER: BHLPL3WGNNBU

Luminaire Lumens 33,341

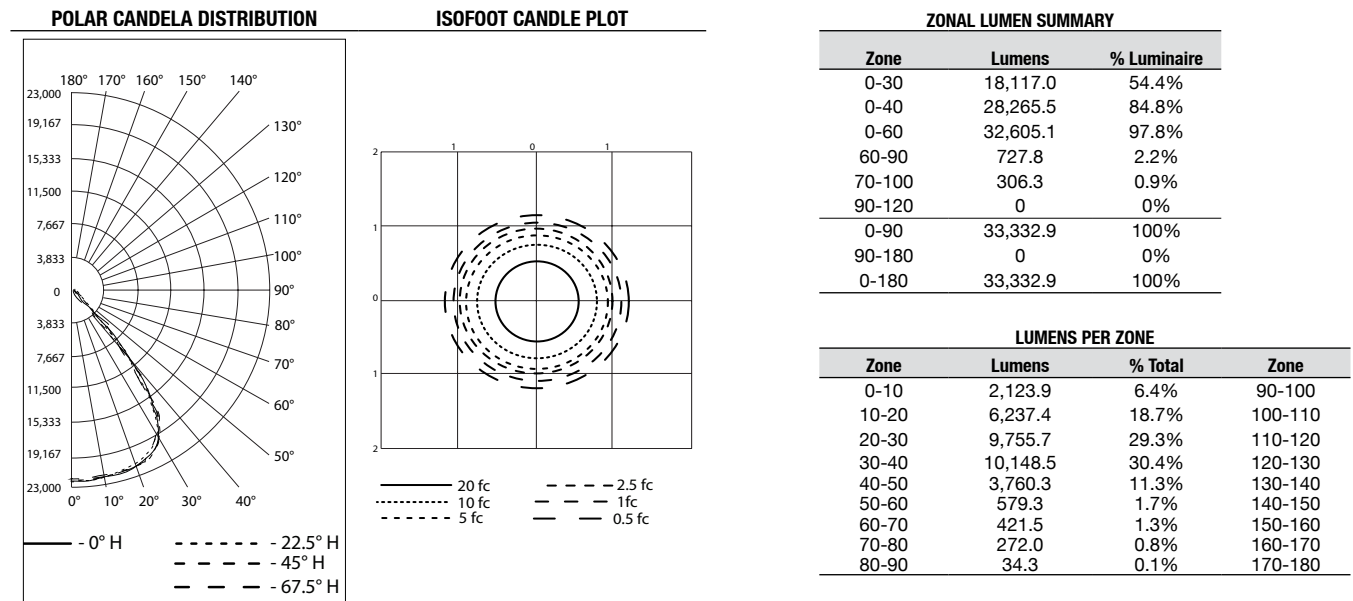

# Baymaster™ and High Lumen LED Luminaire

## High Bay for Hazardous Locations

**NEC/CEC:**  
 Class I, Division 2, Group A, B, C, D  
 Class I, Zone 2 AEx/Ex ec Group IIC Gc  
 Class I, Zone 2, Group IIC  
 Class II, Division 1&2, Group E, F, G  
 Class III

**NEC/CEC:**  
 Zone 20 and 21 Group IIIC  
 Zone 21, AEx/Ex tb Group IIIC Db  
 Simultaneous Exposure  
 Marine Outside Type (Salt Water) for  
 USA Only

**NEC/CEC:**  
 Wet Locations  
 Type 3R, 4 and 4X  
 IP66/67

**ATEX/IECEX:**  
 Zone 2 and 21  
 IP66  
 II 3G 2D  
 IK10  
 Ex ec IIC T5

### Photometric Data – DATA SHOWN IS ABSOLUTE

**Type V Wide, Clear Glass 5000K CCT**

REPORT NUMBER: **BHLPL1CGWNBU**

Luminaire Lumens 20,665

#### POLAR CANDELA DISTRIBUTION

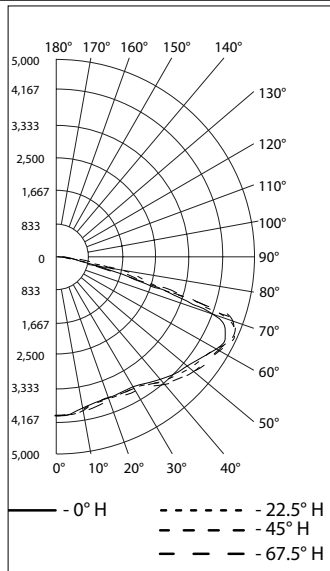

#### ISOFOOT CANDLE PLOT

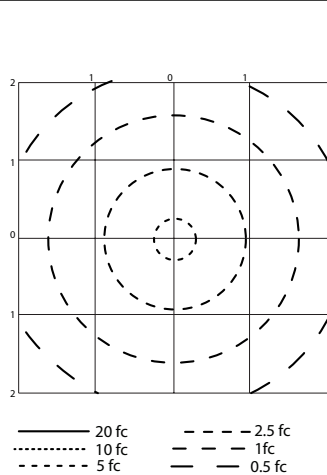

#### FLOOD SUMMARY

Zone	Lumens	% Luminaire
0-30	3,267.5	15.8%
0-40	5,791.9	28%
0-60	13,265.1	64.2%
60-90	7,399.9	35.8%
70-100	2,655.4	12.8%
90-120	0	0%
0-90	20,665.1	100%
90-180	0	0%
0-180	20,665.1	100%

#### LUMENS PER ZONE

Zone	Lumens	% Total	Zone
0-10	381.9	1.8%	90-100
10-20	1,094.7	5.3%	100-110
20-30	1,790.9	8.7%	110-120
30-40	2,524.4	12.2%	120-130
40-50	3,359.2	16.3%	130-140
50-60	4,114.0	19.9%	140-150
60-70	4,744.6	23.0%	150-160
70-80	2,541.1	12.3%	160-170
80-90	114.3	0.6%	170-180

**Type V Wide, Clear Glass 3000K CCT**

REPORT NUMBER: **BHLPL1WGWNBUB**

Luminaire Lumens 18,689

#### POLAR CANDELA DISTRIBUTION

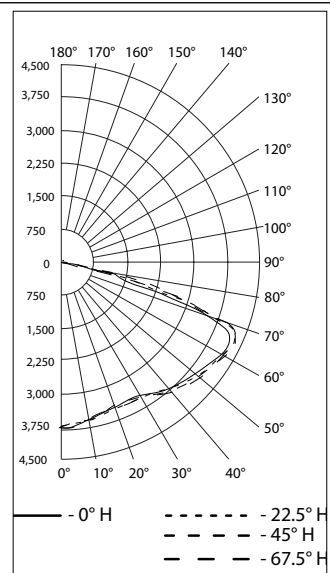

#### ISOFOOT CANDLE PLOT

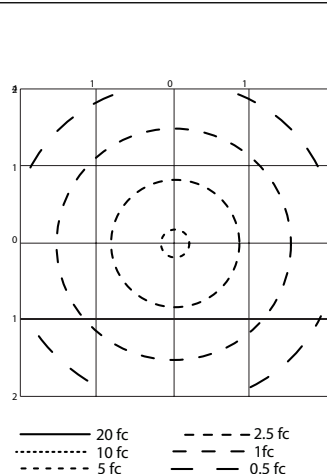

#### FLOOD SUMMARY

Zone	Lumens	% Luminaire
0-30	3,003.0	16.1%
0-40	5,307.9	28.4%
0-60	12,100.9	64.7%
60-90	6,587.8	35.3%
70-100	2,340.7	12.5%
90-120	0	0%
0-90	18,688.8	100%
90-180	0	0%
0-180	18,688.8	100%

#### LUMENS PER ZONE

Zone	Lumens	% Total	Zone
0-10	352.0	1.9%	90-100
10-20	1,008.1	5.4%	100-110
20-30	1,642.9	8.8%	110-120
30-40	2,305.0	12.3%	120-130
40-50	3,058.7	16.4%	130-140
50-60	3,734.3	20.0%	140-150
60-70	4,247.1	22.7%	150-160
70-80	2,247.7	12.0%	160-170
80-90	93.1	0.5%	170-180

LED/HIGH BAY- NEC/CEC ENCLOSED AND GASKETED

APPLETON™

# Baymaster™ and High Lumen LED Luminaire

## High Bay for Hazardous Locations

**NEC/CEC:**

Class I, Division 2, Group A, B, C, D  
 Class I, Zone 2 AEx/Ex ec Group IIC Gc  
 Class I, Zone 2, Group IIC  
 Class II, Division 1&2, Group E, F, G  
 Class III

**NEC/CEC:**

Zone 20 and 21 Group IIIC  
 Zone 21, AEx/Ex tb Group IIIC Db  
 Simultaneous Exposure  
 Marine Outside Type (Salt Water) for  
 USA Only

**NEC/CEC:**

Wet Locations  
 Type 3R, 4 and 4X  
 IP66/67

**ATEX/IECEX:**

Zone 2 and 21  
 IP66  
 II 3G 2D  
 IK10  
 Ex ec IIC T5

**Photometric Data — DATA SHOWN IS ABSOLUTE**

**Type V Wide, Clear Glass 5000K CCT**

REPORT NUMBER: BHLPL2CGWNBU

Luminaire Lumens 25, 896

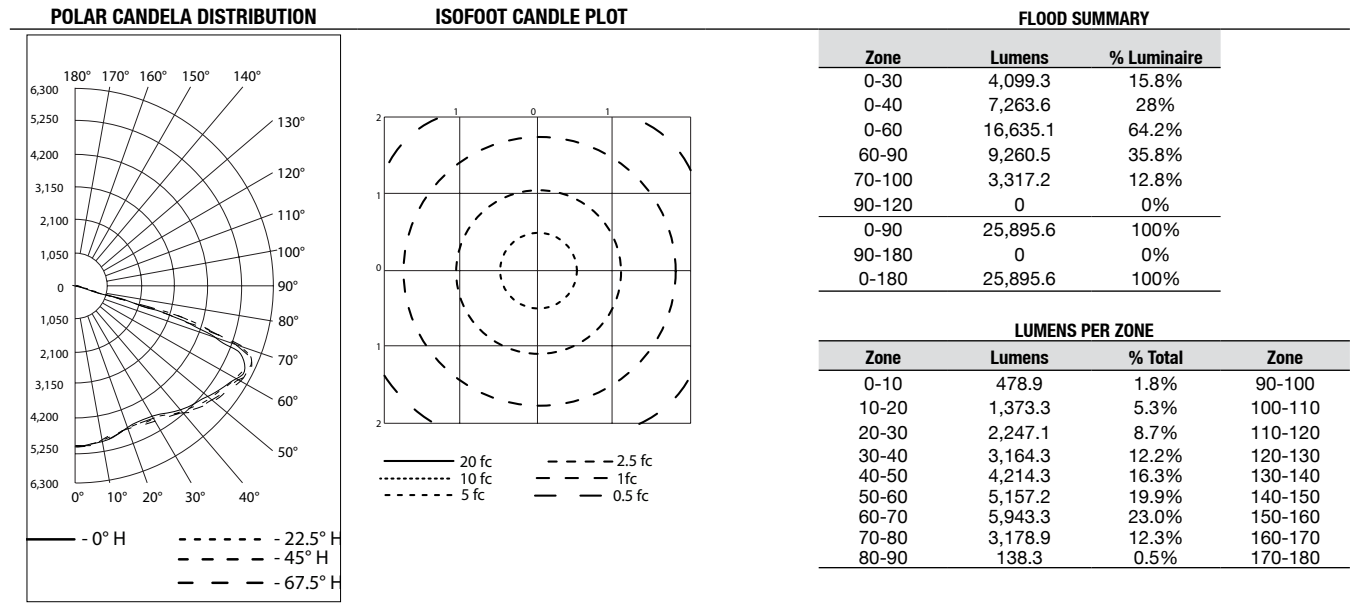

**Type V Wide, Clear Glass 3000K CCT**

REPORT NUMBER: BHLPL2WGWNBUB

Luminaire Lumens 22,278

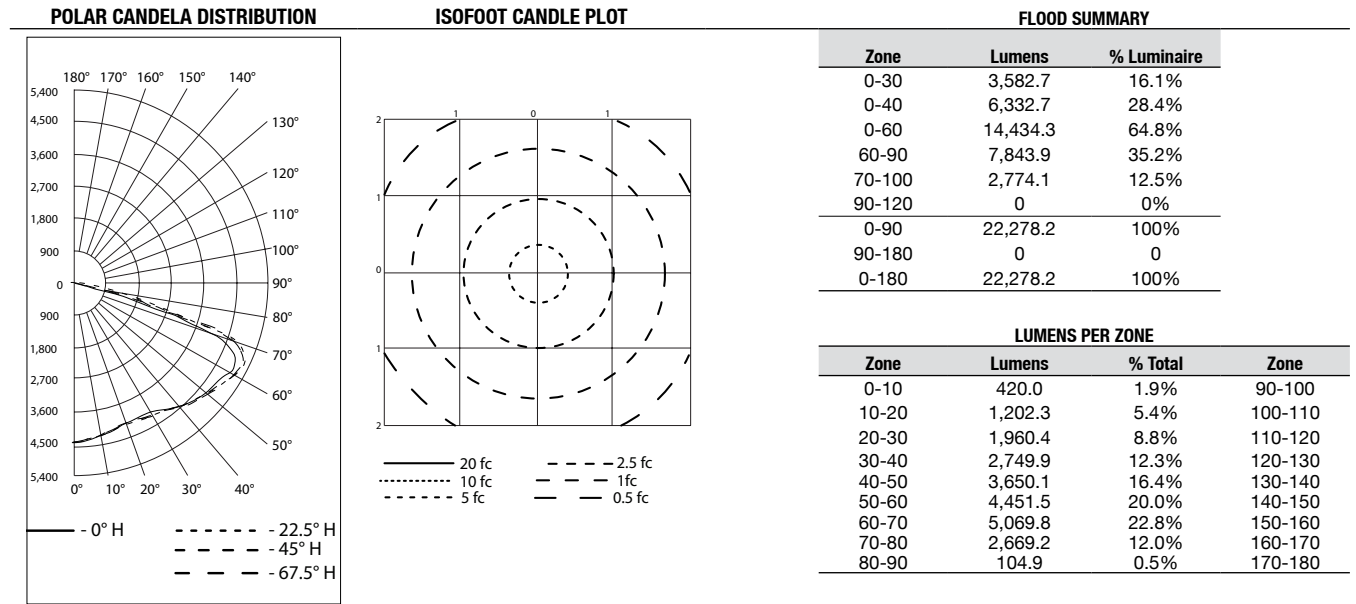

# Baymaster™ and High Lumen LED Luminaire

## High Bay for Hazardous Locations

**NEC/CEC:**  
 Class I, Division 2, Group A, B, C, D  
 Class I, Zone 2 AEx/Ex ec Group IIC Gc  
 Class I, Zone 2, Group IIC  
 Class II, Division 1&2, Group E, F, G  
 Class III

**NEC/CEC:**  
 Zone 20 and 21 Group IIIC  
 Zone 21, AEx/Ex tb Group IIIC Db  
 Simultaneous Exposure  
 Marine Outside Type (Salt Water) for  
 USA Only

**NEC/CEC:**  
 Wet Locations  
 Type 3R, 4 and 4X  
 IP66/67

**ATEX/IECEX:**  
 Zone 2 and 21  
 IP66  
 II 3G 2D  
 IK10  
 Ex ec IIC T5

### Photometric Data – DATA SHOWN IS ABSOLUTE

**Type V Wide, Clear Glass 5000K CCT**

REPORT NUMBER: **BHLPL3CGWNBU**

Luminaire Lumens 33,374

#### POLAR CANDELA DISTRIBUTION

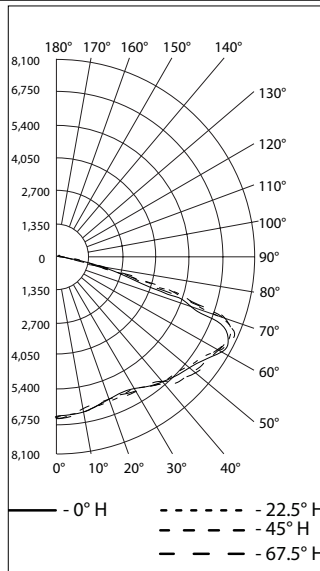

#### ISOFOOT CANDLE PLOT

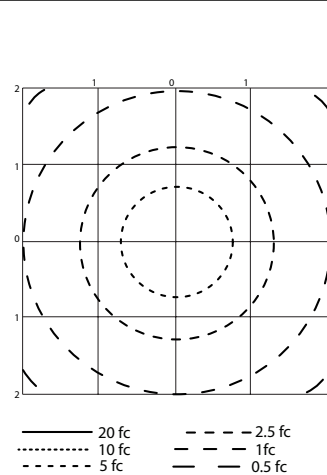

#### FLOOD SUMMARY

Zone	Lumens	% Luminaire
0-30	5,286.5	15.8%
0-40	9,369.3	28.1%
0-60	21,475.2	64.3%
60-90	11,898.9	35.7%
70-100	4,224.4	12.7%
90-120	0	0%
0-90	33,374.1	100%
90-180	0	0%
0-180	33,374.1	100%

#### LUMENS PER ZONE

Zone	Lumens	% Total	Zone
0-10	617.3	1.8%	90-100
10-20	1,771.1	5.3%	100-110
20-30	2,898.1	8.7%	110-120
30-40	4,082.8	12.2%	120-130
40-50	5,443.0	16.3%	130-140
50-60	6,662.9	20.0%	140-150
60-70	7,674.5	23.0%	150-160
70-80	4,065.1	12.2%	160-170
80-90	159.3	0.5%	170-180

**Type V Wide, Clear Glass 3000K CCT**

REPORT NUMBER: **BHLPL3WGWNBUB**

Luminaire Lumens 28,864

#### POLAR CANDELA DISTRIBUTION

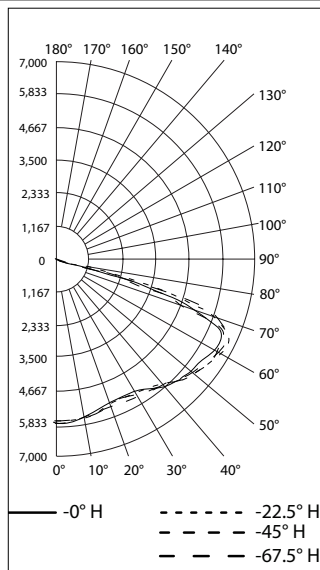

#### ISOFOOT CANDLE PLOT

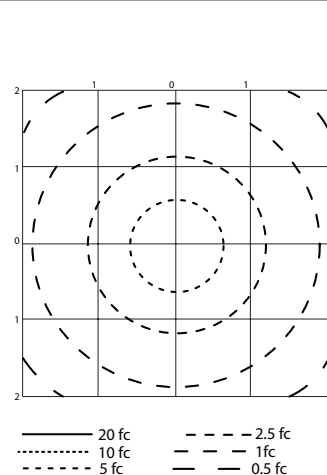

#### FLOOD SUMMARY

Zone	Lumens	% Luminaire
0-30	4,643.3	16.1%
0-40	8,209.1	28.4%
0-60	18,724.5	64.9%
60-90	10,139.9	35.1%
70-100	3,562.1	12.3%
90-120	0	0%
0-90	28,864.4	100%
90-180	0	0%
0-180	28,864.4	100%

#### LUMENS PER ZONE

Zone	Lumens	% Total	Zone
0-10	544.2	1.9%	90-100
10-20	1,558.1	5.4%	100-110
20-30	2,541.0	8.8%	110-120
30-40	3,565.8	12.4%	120-130
40-50	4,737.0	16.4%	130-140
50-60	5,778.4	20.0%	140-150
60-70	6,577.8	22.8%	150-160
70-80	3,431.3	11.9%	160-170
80-90	130.9	0.5%	170-180

LED/HIGH BAY: NEC/CEC ENCLOSED AND GASKETED

APPLETON™



# Baymaster™ and High Lumen LED Luminaire

## High Bay for Hazardous Locations

**NEC/CEC:**

Class I, Division 2, Group A, B, C, D  
 Class I, Zone 2 AEx/Ex ec Group IIC Gc  
 Class I, Zone 2, Group IIC  
 Class II, Division 1&2, Group E, F, G  
 Class III

**NEC/CEC:**

Zone 20 and 21 Group IIIC  
 Zone 21, AEx/Ex tb Group IIIC Db  
 Simultaneous Exposure  
 Marine Outside Type (Salt Water) for  
 USA Only

**NEC/CEC:**

Wet Locations  
 Type 3R, 4 and 4X  
 IP66/67

**ATEX/IECEX:**

Zone 2 and 21  
 IP66  
 II 3G 2D  
 IK10  
 Ex ec IIC T5

**Photometric Data — DATA SHOWN IS ABSOLUTE**

**Type V Medium, Frosted Glass 5000K CCT**

REPORT NUMBER: **BHLPL1CFMNB**

Luminaire Lumens 20,801

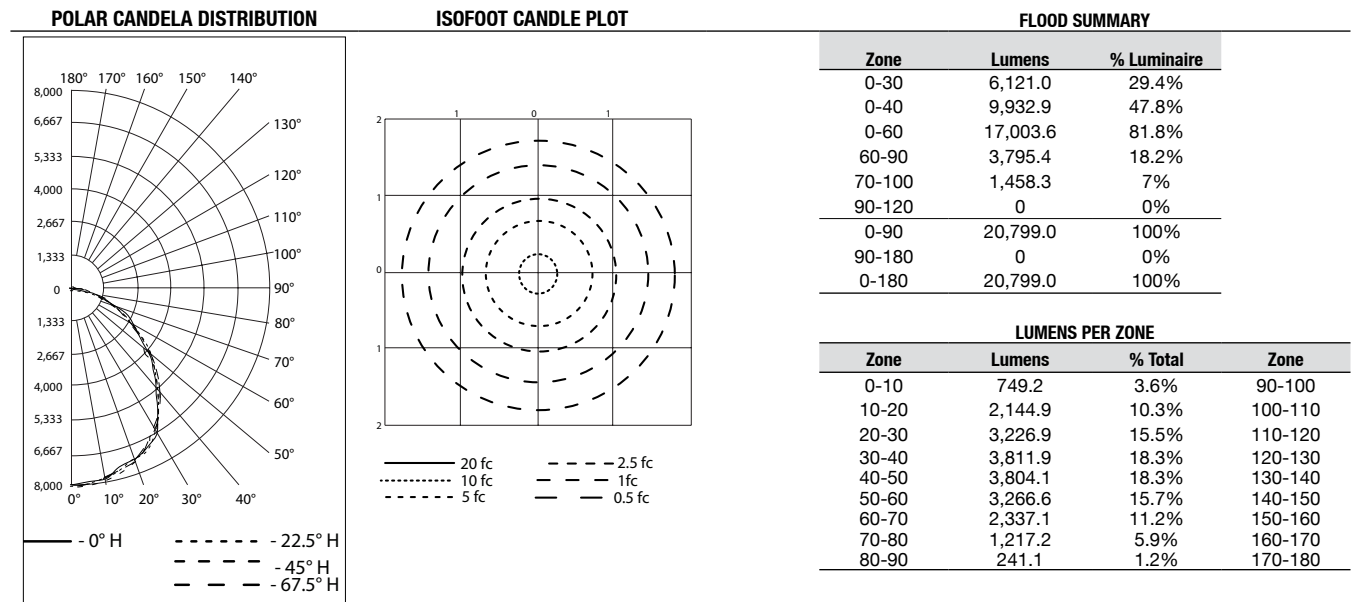

**Type V Medium, Clear Glass 5000K CCT**

REPORT NUMBER: **BHLPL1CGMNB**

Luminaire Lumens 24,352

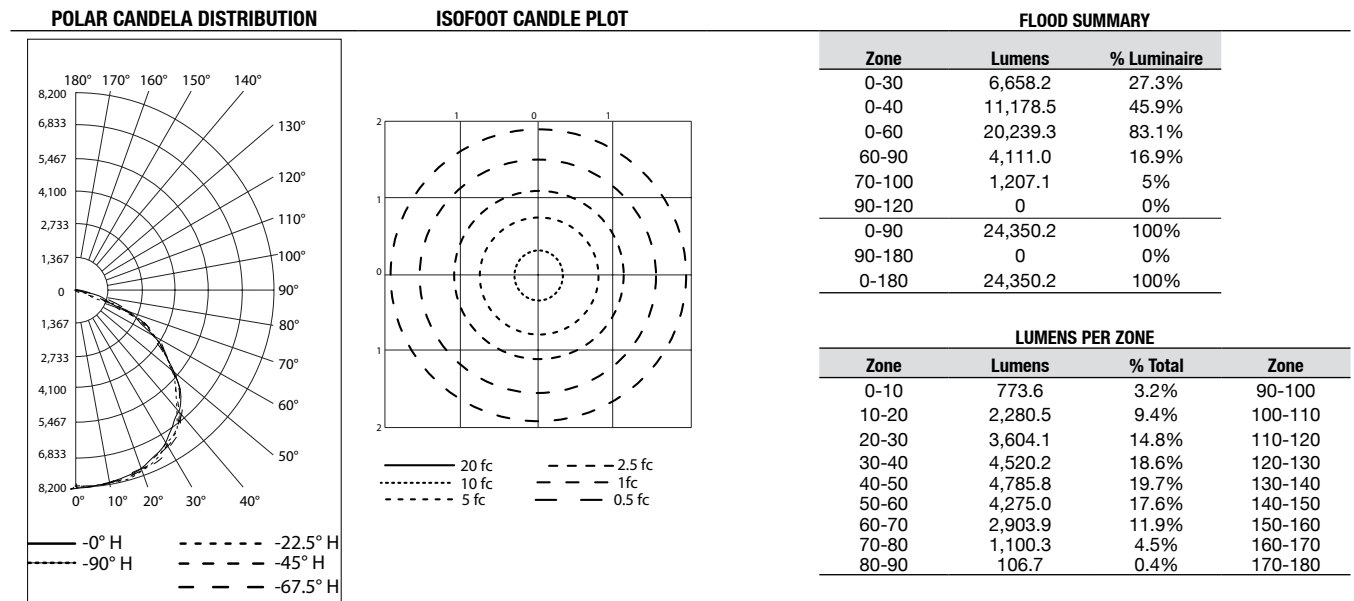

# Baymaster™ and High Lumen LED Luminaire

## High Bay for Hazardous Locations

**NEC/CEC:**

Class I, Division 2, Group A, B, C, D  
 Class I, Zone 2 AEx/Ex ec Group IIC Gc  
 Class I, Zone 2, Group IIC  
 Class II, Division 1&2, Group E, F, G  
 Class III

**NEC/CEC:**

Zone 20 and 21 Group IIIC  
 Zone 21, AEx/Ex tb Group IIIC Db  
 Simultaneous Exposure  
 Marine Outside Type (Salt Water) for USA Only

**NEC/CEC:**

Wet Locations  
 Type 3R, 4 and 4X  
 IP66/67

**ATEX/IECEX:**

Zone 2 and 21  
 IP66  
 II 3G 2D  
 IK10  
 Ex ec IIC T5

**Photometric Data – DATA SHOWN IS ABSOLUTE**

**Type V Medium, Frosted Glass 5000K CCT**

REPORT NUMBER: **BHLPL2CFMNB**

Luminaire Lumens 25,979

**POLAR CANDELA DISTRIBUTION**

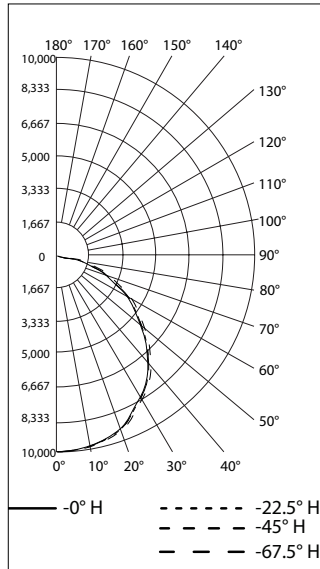

**ISOFOOT CANDLE PLOT**

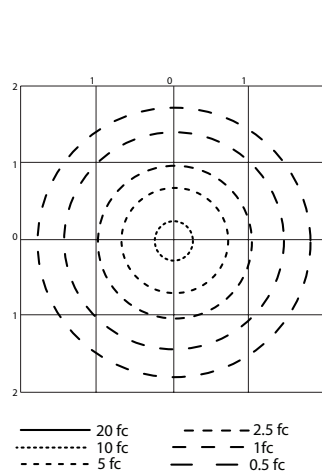

**FLOOD SUMMARY**

Zone	Lumens	% Luminaire
0-30	7,656.5	29.5%
0-40	12,418.0	47.8%
0-60	21,243.5	81.8%
60-90	4,733.5	18.2%
70-100	1,818.2	7%
90-120	0	0%
0-90	25,977.0	100%
90-180	0	0%
0-180	25,977.0	100%

**LUMENS PER ZONE**

Zone	Lumens	% Total	Zone
0-10	937.3	3.6%	90-100
10-20	2,683.1	10.3%	100-110
20-30	4,036.1	15.5%	110-120
30-40	4,761.5	18.3%	120-130
40-50	4,748.8	18.3%	130-140
50-60	4,076.7	15.7%	140-150
60-70	2,915.3	11.2%	150-160
70-80	1,517.9	5.8%	160-170
80-90	300.3	1.2%	170-180

**Type V Medium, Clear Glass 5000K CCT**

REPORT NUMBER: **BHLPL2CGMNB**

Luminaire Lumens 30,375

**POLAR CANDELA DISTRIBUTION**

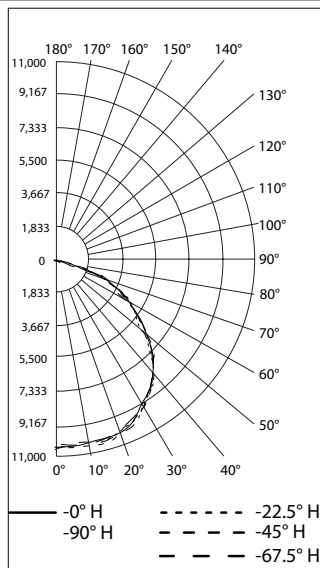

**ISOFOOT CANDLE PLOT**

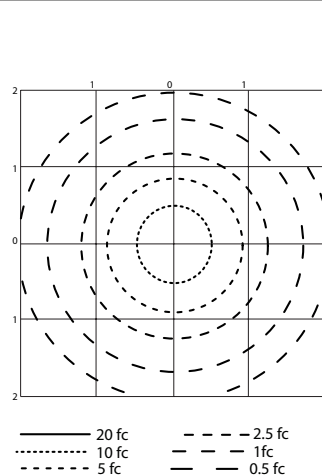

**FLOOD SUMMARY**

Zone	Lumens	% Luminaire
0-30	8,323.9	27.4%
0-40	13,968.9	46%
0-60	25,264.2	83.2%
60-90	5,108.3	16.8%
70-100	1,499.7	4.9%
90-120	0	0%
0-90	30,372.5	100%
90-180	0	0%
0-180	30,372.5	100%

**LUMENS PER ZONE**

Zone	Lumens	% Total	Zone
0-10	967.1	3.2%	90-100
10-20	2,851.3	9.4%	100-110
20-30	4,505.5	14.8%	110-120
30-40	5,645.0	18.6%	120-130
40-50	5,970.4	19.7%	130-140
50-60	5,324.8	17.5%	140-150
60-70	3,608.7	11.9%	150-160
70-80	1,366.3	4.5%	160-170
80-90	133.3	0.4%	170-180

LED/HIGH BAY- NEC/CEC ENCLOSED AND GASKETED

APPLETON™

# Baymaster™ and High Lumen LED Luminaire

## High Bay for Hazardous Locations

**NEC/CEC:**

Class I, Division 2, Group A, B, C, D  
 Class I, Zone 2 AEx/Ex ec Group IIC Gc  
 Class I, Zone 2, Group IIC  
 Class II, Division 1&2, Group E, F, G  
 Class III

**NEC/CEC:**

Zone 20 and 21 Group IIIC  
 Zone 21, AEx/Ex tb Group IIIC Db  
 Simultaneous Exposure  
 Marine Outside Type (Salt Water) for  
 USA Only

**NEC/CEC:**

Wet Locations  
 Type 3R, 4 and 4X  
 IP66/67

**ATEX/IECEX:**

Zone 2 and 21  
 IP66  
 II 3G 2D  
 IK10  
 Ex ec IIC T5

**Photometric Data – DATA SHOWN IS ABSOLUTE**

**Type V, Frosted Glass 5000K CCT**

REPORT NUMBER: **BHLPL3CFMNB**

Luminaire Lumens 32,107

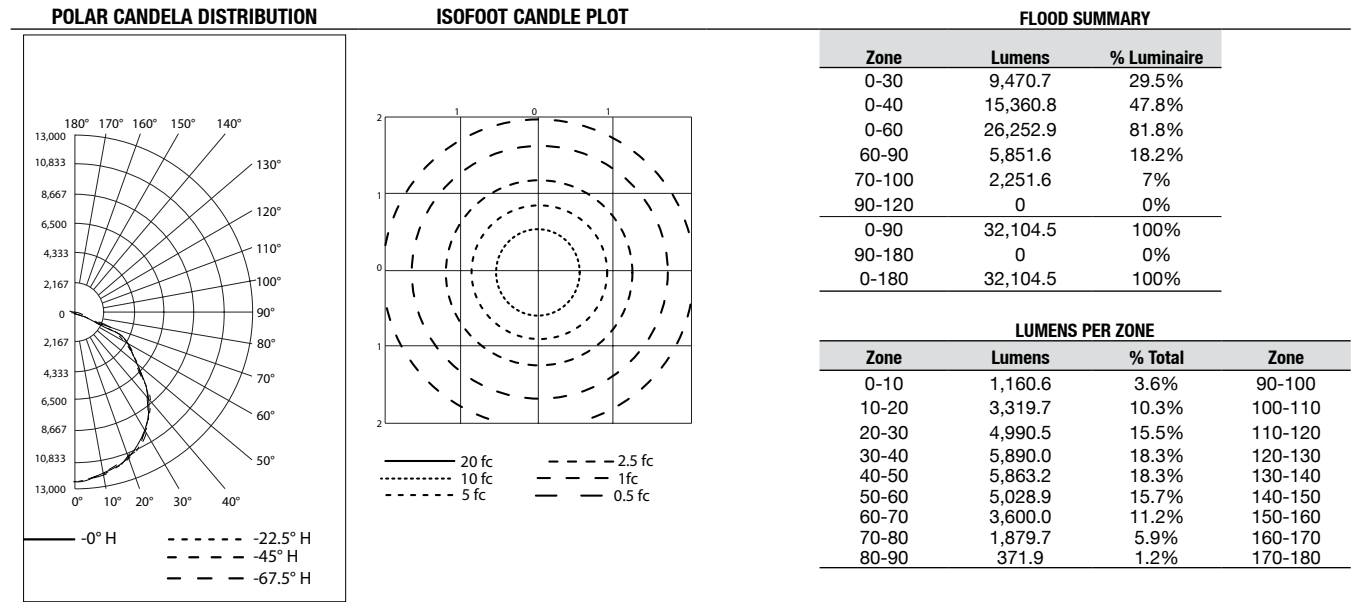

**Type V, Clear Glass 5000K CCT**

REPORT NUMBER: **BHLPL3CGMNB**

Luminaire Lumens 37,574

