

Products

- › Index
- › Featured Products
- › Cross Reference
- › UPC Search

**Product Datasheet**

[Catalog Home](#) [Home Page](#)

[Search](#)

## 6264 -- 1 Device, Rectangular, Fully Adjustable, Cast Iron, Concrete Floor Box

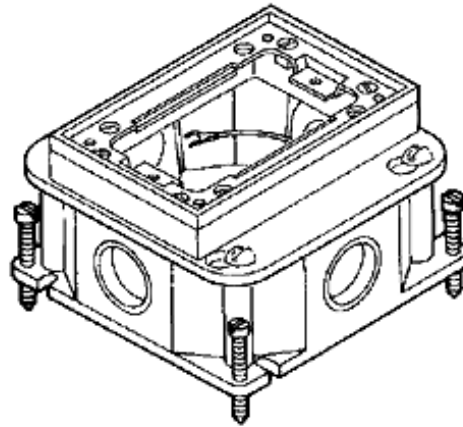

**Product Specifications**

<b>Box Type</b>	RACO Floor Boxes & Covers
<b>Box Family</b>	For Concrete Floors
<b>Box Category</b>	Cast Iron Concrete Floor Boxes
<b>Category</b>	Rectangular Cast Iron
<b>Side Knockout(s)</b>	4, 3/4"
<b>Number of Devices or Gangs</b>	1
<b>Cubic Inch Capacity</b>	30.0
<b>UPC Number</b>	050169062647
<b>Minimum Pack Qty.</b>	4
<b>Material</b>	Cast Iron
<b>Min. Pour Depth</b>	3"
<b>Before Pour Ext. Ht. Adjust.</b>	1.25"
<b>After Pour Int. Final Adjust.</b>	.38"
<b>Unit Carton Quantity</b>	4
<b>Weight (Per/C)</b>	390

**Applications**

- Rectangular series floor boxes are ideally suited for heavy floor traffic applications, such as malls, department stores, banks and schools
- Floor boxes are installed in poured concrete floors and are fed with conduit
- Floor boxes are used in branch circuit wiring

**Product Features**

- Cast iron, water tight body, fully adjustable floor box
- Cast iron construction with gray powder coat finish for corrosion resistance
- 3/4" knockouts; all bottom knockouts are accessible

**Compliances**

UL listed & CSA listed

**Country of Origin**

MADE IN THE U.S.A.

