

**Circuit Breakers**  
Naval Shipboard Use



**EAT•N**

*Powering Business Worldwide*

# Circuit Breakers for Naval Shipboard Use

## Contents

<i>Description</i>	<i>Page</i>	<i>Description</i>	<i>Page</i>	<i>Description</i>	<i>Page</i>	<i>Description</i>	<i>Page</i>
Selector Guide for Navy Circuit Breakers . . . . .	<b>2</b>	<b>Types AQB-A51, NQB-A51</b> . . . . .	<b>23</b>	<b>Types AQB-A250, NQB-A250</b> . . . . .	<b>48</b>	<b>Type NQB-A803</b> . . . . .	<b>98</b>
General Information . . . . .	<b>3</b>	Product Selection . . . . .	<b>23</b>	Product Selection . . . . .	<b>48</b>	Product Selection . . . . .	<b>98</b>
Design Features . . . . .	<b>3</b>	Outline Dimensions . . . . .	<b>25</b>	Outline Dimensions . . . . .	<b>54</b>	Outline Dimensions . . . . .	<b>99</b>
Standard Features . . . . .	<b>4</b>	Time-Current Curve . . . . .	<b>28</b>	Time-Current Curve . . . . .	<b>59</b>	<b>Types AQB-A1601, NQB-A1601</b> . . . . .	<b>100</b>
Application . . . . .	<b>5</b>	<b>Types AQB-A100, NQB-A100</b> . . . . .	<b>29</b>	<b>Types AQB-LF100, AQB-LF250</b> . . . . .	<b>60</b>	Product Selection . . . . .	<b>100</b>
General Ordering Information . . . . .	<b>5</b>	Product Selection . . . . .	<b>29</b>	Product Selection . . . . .	<b>61</b>	Outline Dimensions . . . . .	<b>102</b>
Marine Breaker Application . . . . .	<b>5</b>	Outline Dimensions . . . . .	<b>32</b>	Outline Dimensions . . . . .	<b>65</b>	Time-Current Curve . . . . .	<b>107</b>
<b>Types ALB-1, NLB-1</b> . . . . .	<b>6</b>	Time-Current Curve . . . . .	<b>33</b>	Time-Current Curve . . . . .	<b>69</b>	<b>Types AQB-A1602, NQB-A1602</b> . . . . .	<b>109</b>
Product Selection . . . . .	<b>6</b>	<b>Types AQB-A101, NQB-A101</b> . . . . .	<b>34</b>	<b>Types AQB-A253, AQB-L253, NQB-A253</b> . . . . .	<b>70</b>	Product Selection . . . . .	<b>110</b>
Outline Dimensions . . . . .	<b>8</b>	Product Selection . . . . .	<b>34</b>	Product Selection . . . . .	<b>71</b>	Outline Dimensions . . . . .	<b>111</b>
Time-Current Curve . . . . .	<b>16</b>	Outline Dimensions . . . . .	<b>38</b>	Outline Dimensions . . . . .	<b>75</b>	Time-Current Curve . . . . .	<b>112</b>
<b>Types AQB-A50, NQB-A50</b> . . . . .	<b>17</b>	Time-Current Curve . . . . .	<b>42</b>	Time-Current Curve . . . . .	<b>77</b>	<b>Types ACB 1600/2000HR — 3200/4000HR</b> . . . . .	<b>113</b>
Product Selection . . . . .	<b>17</b>	<b>Types AQB-A103 RMS, NQB-A103</b> . . . . .	<b>44</b>	<b>Types AQB-L400, AQB-LL400, NQB-LL400</b> . . . . .	<b>78</b>	Outline Dimensions . . . . .	<b>115</b>
Outline Dimensions . . . . .	<b>19</b>	Product Selection . . . . .	<b>44</b>	Product Selection . . . . .	<b>79</b>	Time-Current Curve . . . . .	<b>117</b>
Time-Current Curve . . . . .	<b>22</b>	Time-Current Curve . . . . .	<b>45</b>	Outline Dimensions . . . . .	<b>83</b>		
				Time-Current Curve . . . . .	<b>86</b>		

## Circuit Breakers for Naval Shipboard Use

5 to 4000 Amperes, 1500 to 150,000 Amperes I.C.

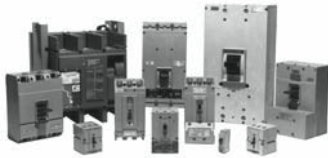

## SELECTOR GUIDE FOR NAVY CIRCUIT BREAKERS

BREAKER TYPE	SPECIFICATION	HI-SHOCK SPEC	NO. OF POLES	AMPERE RATING	VOLTAGE RATING	INTERRUPTING RATING, AMPERES <sup>①</sup>	TRIPPING ELEMENTS	PAGE
ALB-1	MIL-C-17588	MIL-S-901	1	5 – 50	125 Vdc 125 Vac	2,500 <sup>②</sup> 5,000 <sup>②</sup>	Thermal Magnetic	<b>6</b>
NLB-1	MIL-C-17588	MIL-S-901	1	50	125 Vdc 125 Vac	—	None	<b>6</b>
AQB-A50	MIL-C-17361	MIL-S-901	3	10 – 50	500 Vac	5,000 <sup>③</sup>	Thermal Magnetic	<b>17</b>
NQB-A50	MIL-C-17361	MIL-S-901	3	50	500 Vac	—	None	<b>17</b>
AQB-A51	MIL-C-17361	MIL-S-901	3	10 – 50	500 Vac	5,000	Thermal Magnetic	<b>23</b>
NQB-A51	MIL-C-17361	MIL-S-901	3	50	500 Vac	—	None	<b>23</b>
AQB-A100	MIL-C-17361	MIL-S-901	2, 3	15 – 100	250 Vdc 500 Vac	10,000 15,000 <sup>③</sup>	Thermal Magnetic	<b>29</b>
NQB-A100	MIL-C-17361	MIL-S-901	2, 3	100	250 Vdc 500 Vac	—	None	<b>29</b>
AQB-A101	MIL-C-17361	MIL-S-901	3	15 – 100	250 Vdc 500 Vac	10,000 15,000 <sup>③</sup>	Thermal Magnetic	<b>34</b>
NQB-A101	MIL-C-17361	MIL-S-901	3	100	250 Vdc 500 Vac	—	None	<b>34</b>
AQB-A103	MIL-C-17361	MIL-S-901	3	10 – 100	500 Vac	15,000 <sup>③</sup>	Electronic	<b>44</b>
NQB-A103	MIL-C-17361	MIL-S-901	3	100	500 Vac	—	None	<b>44</b>
AQB-A250	MIL-C-17361	MIL-S-901	2, 3	100 – 250	250 Vdc 500 Vac	15,000 20,000 <sup>③</sup>	Thermal Magnetic	<b>48</b>
NQB-A250	MIL-C-17361	MIL-S-901	2, 3	250	250 Vdc 500 Vac	—	None	<b>48</b>
AQB-LF100	MIL-C-17361	MIL-S-901	3	15 – 100	500 Vac	100,000	Thermal Magnetic Fuses	<b>60</b>
AQB-LF250	MIL-C-17361	MIL-S-901	3	125 – 250	500 Vac	100,000	Thermal Magnetic Fuses	<b>60</b>
AQB-A253	MIL-C-17361	MIL-S-901	3	100 – 250	500 Vac	30 kA	Electronic	<b>70</b>
AQB-L253	MIL-C-17361	MIL-S-901	3	100 – 250	500 Vac	100 kA	Electronic	<b>70</b>
NQB-A253	MIL-C-17361	MIL-S-901	3	250	500 Vac	—	None	<b>70</b>
AQB-LL400	MIL-C-17361	MIL-S-901	3	250 – 400	500 Vac	150,000 <sup>③</sup>	Electronic	<b>78</b>
AQB-LL400	MIL-C-17361	MIL-S-901	3	250 – 400	500 Vac	100,000 <sup>③</sup>	Electronic	<b>78</b>
NQB-LL400	MIL-C-17361	MIL-S-901	3	400	500 Vac	—	None	<b>79</b>
NQB-A803	MIL-C-17361	MIL-S-901	3	800 at 60 Hz	500 Vac	—	None	<b>98</b>
NQB-A803	MIL-C-17361	MIL-S-901	3	650 at 400 Hz	500 Vac	—	None	<b>98</b>
AQB-A1601	MIL-C-17361	MIL-S-901	3	500 – 1600	500 Vac	75,000	Thermal Magnetic	<b>100</b>
NQB-A1601	MIL-C-17361	MIL-S-901	3	1600	500 Vac	—	None	<b>100</b>
AQB-A1602	MIL-C-17361	MIL-S-901	3	400 – 1600	500 Vac	100,000	Electronic	<b>109</b>
NQB-A1602	MIL-C-17361	MIL-S-901	3	1600	500 Vac	100,000	None	<b>109</b>
ACB 1600HR ACB 4000HR	MIL-C-17587	MIL-S-901	3	320 – 4000	500 Vac	85,000	Electronic	<b>113</b>

<sup>①</sup> ACB ratings are symmetrical; all others are asymmetrical.

<sup>②</sup> A 5 ampere breaker has an interrupting rating of 1500 amperes ac or dc.

<sup>③</sup> See MIL-spec or call Eaton for 400 Hz ratings.

# General Information

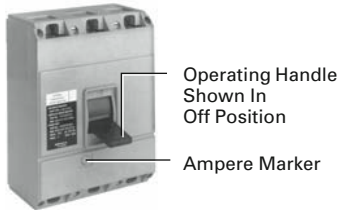

Operating Handle Shown In Off Position  
Ampere Marker

**Front view of assembled AQB-A250 Navy circuit breaker. Note that the shock resistant material (MIL-M-14) used for housing and cover is light gray.**

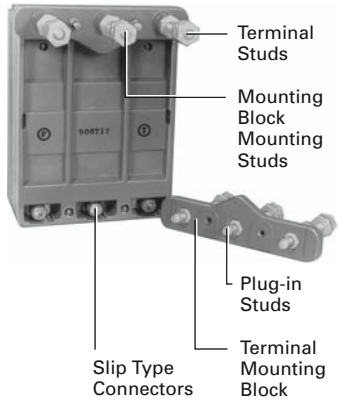

Terminal Studs  
Mounting Block Mounting Studs  
Plug-in Studs  
Terminal Mounting Block  
Slip Type Connectors

**Rear view of breaker showing terminal blocks for switchboard mounting. (Terminal block attached at line end of breaker and removed from load end.)**

## Description

These molded case Navy circuit breakers provide both overload protection for conductors and short circuit protection for all circuit elements such as conductors, motors and starters. They also serve as manual disconnecting means as well as circuit protectors.

All Eaton's Cutler-Hammer® circuit breakers in this Product Guide meet applicable Navy specifications for "hi-shock." These manually operated breakers are rated from 5 to 4,000 amperes with interrupting ratings from 1,500 to 150,000 amperes. (See "Selector Guide" on **Page 2** for ratings and Navy specifications.)

## Design Features

Cutler-Hammer Navy circuit breakers retain all the features of standard commercial type AB DE-ION breakers listed on **Page 4** under "standard features." Built to Navy specifications, they incorporate the following Navy requirements:

## Specific Navy Features

- **Qualified Products** — All Navy circuit breakers undergo rigorous qualification testing to MIL-C-17361 and are listed on the associated Qualified Products List issued by the federal government. (ACB's per MIL-C-17587, ALB-1's per MIL-C-17588, and AQB's per MIL-C-17361.)

- **Shock-Resistant Molded Case** — Housing consists of rear base section and cover molded of glass alkyd material. This material, reinforced glass filled thermosetting plastic, has very high mechanical strength (shock and impact resistance), is both fire and moisture-resistant and provides excellent dielectric characteristics.
- **Anti-Shock Device** — Inertia weight over center pole holds trip bar in latched position under shock conditions but does not prevent thermal or magnetic trip units from functioning on overload and short circuits.
- **Shock and Vibration Resistant** — Navy circuit breakers are all tested to MIL-S-901 for Hi Impact Shock, and MIL-STD-167 for Mechanical Vibration. This test ensures that the circuit breakers will operate properly in the Naval shipboard environment.
- **EMI Resistant** — All Navy circuit breakers with Electronic Trip Units (ETUs) are tested for electromagnetic immunity and emissions per MIL-STD-461 and -462 to eliminate interference from radiated or conducted EMI.
- **50°C Calibrated** — Thermal-magnetic circuit breakers are calibrated for 50°C ambient temperature. The calibration of circuit breakers with ETUs are inherently unaffected by ambient temperature.
- **Interchangeable Trip Units** — All thermal and magnetic trip units in AQB circuit breakers are encased in sealed, self-contained units that are interchangeable with other trip units of different ampere ratings within the same frame size.
 

**Note:**  
Interchangeable trip units are not available in the A101, ALB-1, A50 or A51.
- **Plug-in Connectors** — All Navy circuit breakers are designed for optional molded plug-in bases in a variety of styles. Smaller breakers (ALB-1, A50 and A51) must be used with the associated bases. Other MCCBs can be converted for direct cable or plug-in mount. Plug in bases are available in a variety of styles depending upon the circuit breaker type. See the specific circuit breaker style for available mounting bases and outline drawings.
 

**Note:**  
All A101, A50 or A51 breakers have plug-in connectors. Front or rear connectors determined by mounting base selected.

ALB breakers have a clamp terminal on the line end to receive panelboard bus stab projections.
- **Interrupting Ratings to 150 kA** — Navy circuit breakers are available with interrupting ratings up to 150 kA, many using modern fuseless current-limiting technology. Circuit breakers rated 100 ampere and below must be used with associated current limiting fuses to achieve high interrupting capacity.

# General Information

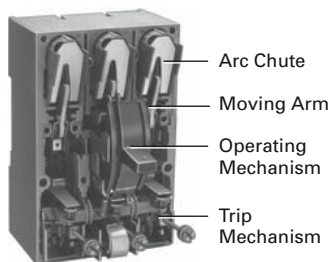

Arc Chute  
Moving Arm  
Operating Mechanism  
Trip Mechanism



Breaker Front Cover Removed



Arc Chute Removed



Molded Operating Handle Removed

## Standard Features

- **Corrosion-Resistant** — All parts are specially treated to resist corrosion. Fungus-moisture resistant treatments for severe atmospheres are available as modifications.
- **Positive Position Indication** — Position of handle always indicates ON, OFF, or TRIPPED.
- **Free-Bearing Surfaces** — Dissimilar metals are used to prevent bearing wear and eliminate sticking.
- **DE-ION® Arc Quenchers** — This Eaton development consists of a series of grid plates mounted in parallel between supports of insulating material. The slots in the steel plates are directly over the contacts and draw the arc from the moving contact up into the divided chamber where it is confined, divided, and extinguished.
- **Silver Alloy Contacts** — Special silver alloy contacts prevent sticking and welding, increase contact life and insure low resistance when carrying full-rated load.
- **Quick-Make, Quick-Break Over Center Toggle Mechanism** — Provides quick, positive action in opening and closing of circuits, prevents “teasing” of contacts and reduces contact wear.
- **Complete Interpole Barriers** — Ensure against internal flashovers when faults occur.
- **Common Trip** — Two and three-pole units have insulated common trip bar that opens all poles simultaneously when an overload occurs on any one, thus eliminating possibility of single-phasing.
- **Tested Accuracy** — All tripping members have ground and polished latch surfaces heat treated to prevent galling or later distortion. All parts are tested in temperature-controlled atmosphere to ensure correct calibration and perfect mating. Each breaker is thoroughly tested.
- **Factory Sealed** — Smaller breakers are factory sealed to prevent tampering with calibration. Interchangeable trip units are individually sealed.

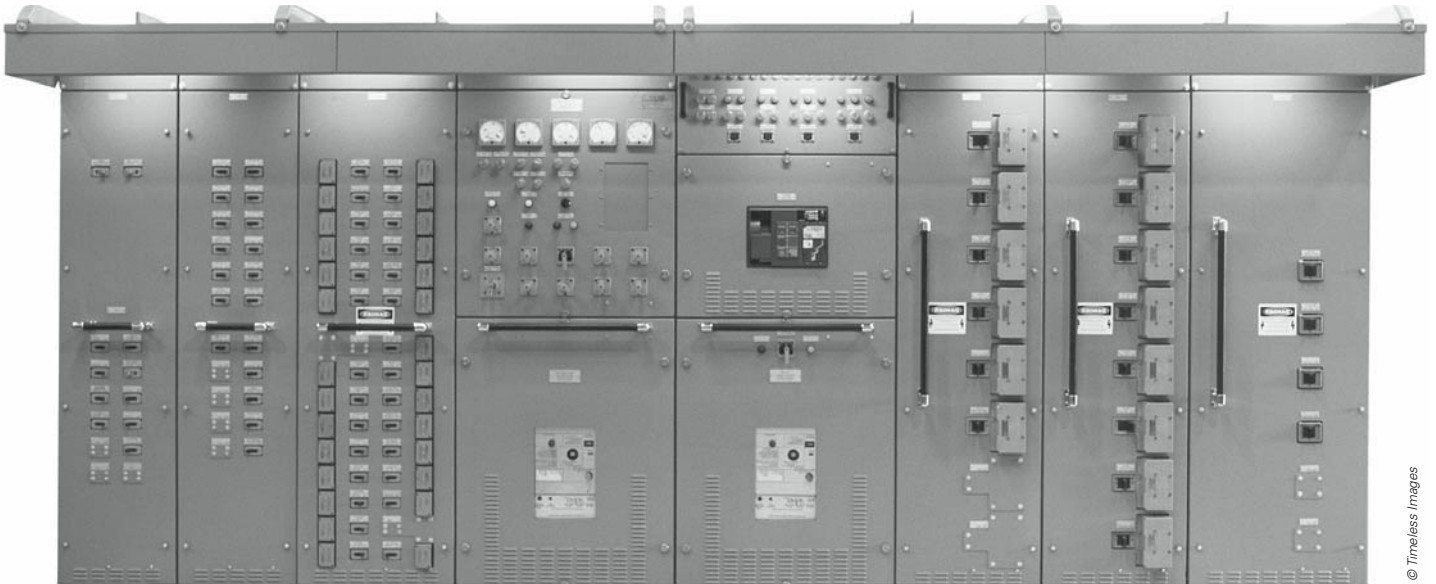

© Timeless Images

## Application

Designed primarily for circuit protection, Cutler-Hammer Navy circuit breakers are used in lighting and power panels, switchboards, distribution centers and load centers aboard ship. The photograph above illustrates the use of molded case circuit breakers and air circuit breakers in a typical Navy switchboard.

## General Ordering Information

When ordering Cutler-Hammer Navy circuit breakers, consult the check list below to make sure you have provided correct information. You should specify:

1. Quantity, Cutler-Hammer Part Number and National Stock Number of:
  - a. Complete breaker or frame, trip unit, fuses (where required) and/or attachments where available.
  - b. Plug-in mounting block or front connecting cable terminals.
  - c. Spare breakers or trip units. (Usually one required for each 10 units or fraction thereof of each current rating.)
  - d. Technical Manuals.
2. Shipment  
Specify transportation means, method of packaging and preservation, and required shipping date.
3. Drawings  
Specify quantity of outline or master plan drawings required.
4. Inspection  
Indicate whether Government Source Inspection (GSI) is required at factory prior to shipment. This should appear as a "shipping note."

## Marine Breaker Applications

Eaton also manufactures a complete family of marine circuit breakers for Navy non-combatant ships, U.S. Coast Guard vessels, Military Sealift Command vessels, commercial vessels, offshore drilling rigs, etc. These marine breakers are different from high shock MIL-spec breakers. They meet any or all of various marine specifications such as ABS, USCG-CFR46, IEEE45, UL® 489 Supplements SA and SB, UL 1066 Supplement SA, Lloyd's of London, DNV. Call Eaton for more details.

# Types ALB-1 and NLB-1

## Circuit Breakers for Naval Shipboard Use — Types ALB-1 and NLB-1 Breakers

125 Volts ac and dc, 50 Amperes  
Maximum, 5000 Amperes I.C.



ALB-1 Navy Circuit Breaker

### Note:

Clamp type stab terminal for panelboard mounting at line end and pressure type terminal for front connection at load end.

### Specification: MIL-C-17588

- 5 – 50 amperes, 60 or 400 cycle.
- 125 volts ac or dc single-pole.

### Interrupting Rating

10 – 50 ampere units:  
5,000 amperes ac and 2,500  
amperes dc.

5 ampere unit: 1,500 amperes  
ac or dc.

High shock Navy ALB-1 circuit breakers are designed for shipboard protection of single-phase ac and dc circuits or three-phase ac circuits when breakers are connected by handle yokes for 2- and 3-pole operation.

The NLB-1 breaker is the non-automatic design of the ALB-1. Since the tripping element is omitted, it is used as a manual disconnect.

Non-adjustable thermal and magnetic trip elements are factory calibrated and sealed. The tripping element is counterbalanced to reduce possibility of accidental tripping under shock. All parts are given a corrosion-resistant treatment in compliance with MIL-E-917.

Plug-in line connections simplify panelboard mounting. A clamp type terminal on the line end of the breaker provides plug-in connection to bus stabs in panelboard mounting blocks. For front connection, there is a pressure type terminal on the load end of the breaker.

## ALB-1 AND NLB-1 CIRCUIT BREAKER PRODUCT SELECTION — NET WEIGHT 8 OZ. ①

TYPE	AMPERE RATING	STYLE NUMBER	NATIONAL STOCK NUMBER
ALB-1	5	454D507G01	5925-00-204-7494
ALB-1	10	454D507G02	5925-00-204-7488
ALB-1	15	454D507G03	5925-01-244-1756
ALB-1	20	454D507G04	5925-00-501-5051
ALB-1	25	454D507G05	5925-00-549-5359
ALB-1	30	454D507G06	5925-00-549-5360
ALB-1	35	454D507G07	5925-00-549-5362
ALB-1	40	454D507G08	5925-00-546-3076
ALB-1	50	454D507G09	5925-00-549-5365
NLB-1 ②	50	454D507G10	5930-00-548-7068

① For list prices, see Price and Availability Digest (PAD).

② Tripping element omitted for manual disconnect. Letter "N" hot stamped in white on handle.

### Special ALB-1 and NLB-1 Breakers

Similar to above except to have a 1A-1B auxiliary switch rated 5 ampere resistive, 250 volts ac or 30 volts dc maximum (Not submitted for Navy approval, and does not use breaker mounting bases.) Order by description.

## Mounting Bases

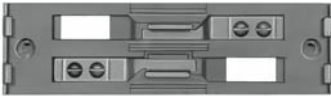

Top View of Typical ALB-1 Panelboard Mounting Base (Style 454D509G04)

### Drawings Available

Master drawing 900J396; breaker outline 314C218; mounting bases 455D791 and 369D592.

### Technical Manual

NAVSHIPS No. 362-2228. This booklet per MIL-M-15071. When required, order BVR-TM-378.

### Note:

These breakers are non-repairable per NAVSEA letter, serial number 9077 Ser 03/03 EI-48, paragraph 3 Policy, sub-paragraph 2, dated 25 October 1994.

## PANELBOARD MOUNTING AND ACCESSORIES

TYPE	STYLE NUMBER	NATIONAL STOCK NUMBER	NET WEIGHT, LBS. (KG)
Single Breaker, Front Panel Supported	454D509G01	5925-01-005-4983	.25 (0.11)
Single Breaker, Surface Mounted	454D509G02	5925-00-177-6349	.25 (0.11)
Two Breakers, Front Panel Supported	454D509G03	5925-01-343-9108	.50 (0.23)
dc, Single-Phase ① and Part (1/3) of Combination for 3-Phase ②	454D509G04	5925-00-660-3562	.67 (0.3)
Part (2/3) of Combination for 3-Phase Application ③	454D509G05	5925-00-201-7175	.67 (0.3)
3-Phase Panel Application ③	454D509G06	5925-00-544-5980	1.00 (0.5)
dc, Single-Phase ① and Part (1/3) of Combination for 3-Phase ②	454D509G08	5925-00-201-7176	.67 (0.3)

① In dc or single-phase panel applications, basic pattern is one molded base accommodating four single-pole breakers. (See Pages 10 – 12.)

② In 3-phase application where basic pattern is three molded bases, one 454D509G04 and two 454D509G05 are required, each base accommodating two breakers per circuit. (See Page 10.)

③ For 3-phase application where basic pattern is one molded base accommodating up to six breakers or two breakers per circuit. (See Pages 12 – 14.)

Ordering Information: See Page 5.

### Individual Reproductions

When required, reproductions of master drawings, outline drawings and certification sheets can be ordered as follows:

ITEM	DESCRIPTION
1	Full Size Photolithographic Tracing of Master Drawing on Vellum
2	Outline and Drilling Plan on Vellum
3	Certification Data on Vellum
4	Reproductions of Items 1, 2 or 3

### Handle Yokes

Provide interlocking of two or three one-pole breakers for simultaneous operation. Individual pole tripping is obtained without normal trip indicating (center) position.

NUMBER OF POLES	STYLE NUMBER	NATIONAL STOCK NUMBER
2	207B508H01	5925-00-202-0938
3	207B508H02	5930-00-862-5582



# Types ALB-1 and NLB-1

## Outline Dimensions ALB-1 Breaker and Mounting Bases — Dimensions in Inches

### Breaker Outline

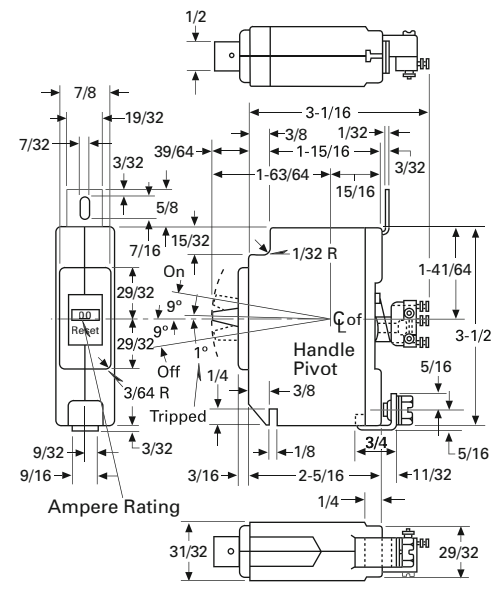
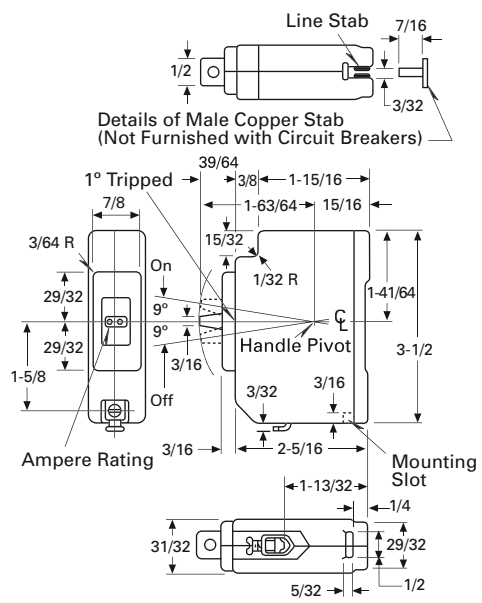

**STANDARD BREAKER**

**SPECIAL BREAKER WITH AUXILIARY SWITCH**

### Single Base, Front Panel Supported (454D509G01)

2 Screws, Steel, .190-32 X 3 Furnished with Lockwashers for Securing to Panel Front Cover .190-32 Tap (2 Holes)

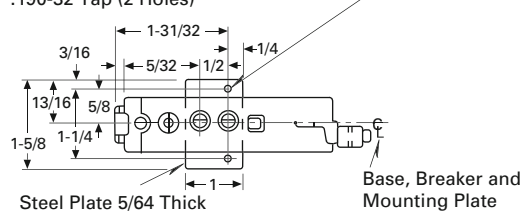

### Two Breaker Base, Front Panel Supported (454D509G03)

2 Screws, Steel, .190-32 X 3 Furnished with Lockwashers for Securing to Panel Front Cover .190-32 Tap (2 Holes)

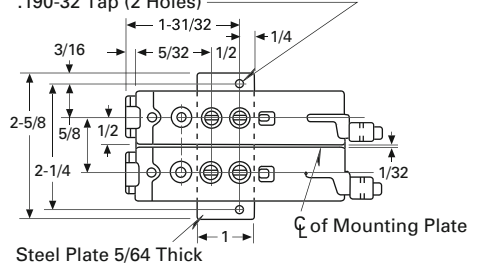

**Single Base  
Surface Mounted  
(454D509G02)**

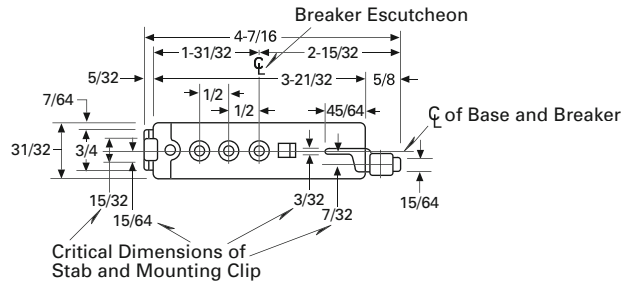

**Mounting of Surface  
Mounted Bases**

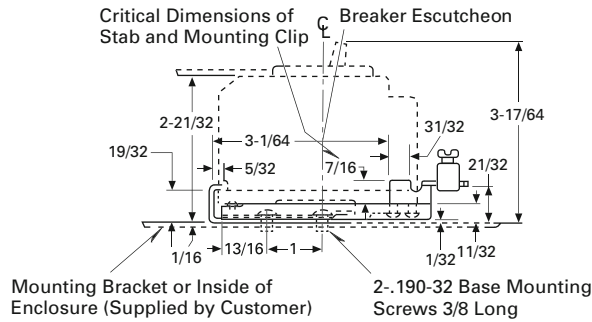

**SIDE VIEW**

**Mounting of Front Panel  
Supported Bases**

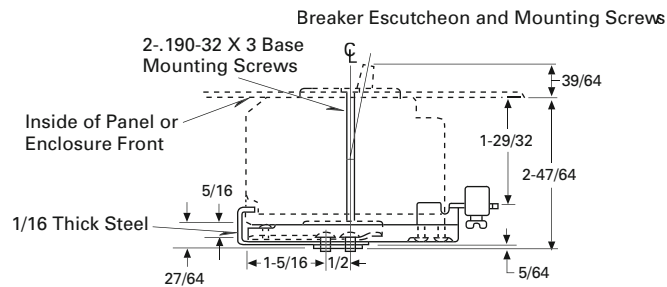

**SIDE VIEW**

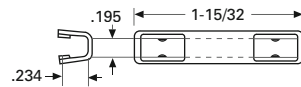

**2-POLE HANDLE YOKE  
(207B508H01)**

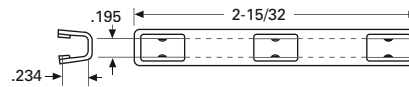

**3-POLE HANDLE YOKE  
(207B508H02)**

# Types ALB-1 and NLB-1

## Outline Dimensions ALB-1 Breaker and Mounting Bases — Dimensions in Inches, Continued

### Application in dc and Single-Phase Panels

(Two Separate Bases shown. Basic Pattern is One Molded Base Accommodating Four Single-Pole Breakers)

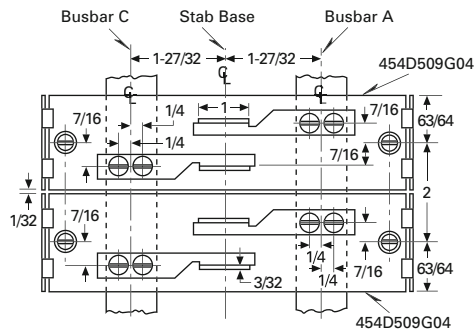

**FRONT VIEW**

### 3-Phase Panel Application for Two Breakers Per Load Circuit

(Basic Pattern of Three Separate Molded Bases can be Repeated for Longer Panel Boards)

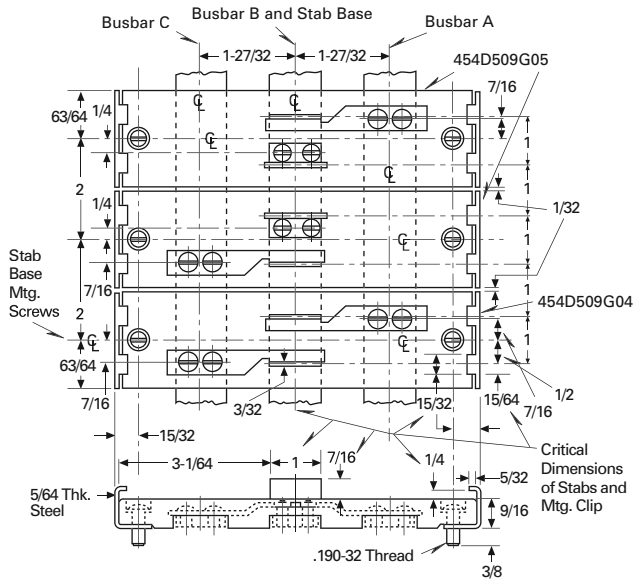

**SIDE VIEW**

### Outline Dimensions for Mounting Bases 454D509G04 or 454D509G05

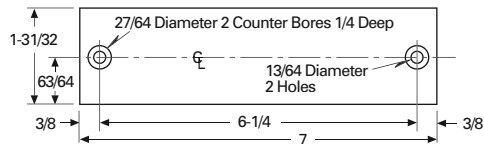

**Bus Bar Drilling for dc and Single-Phase Panels**

(1/4 x 1 Copper Bus not Supplied)

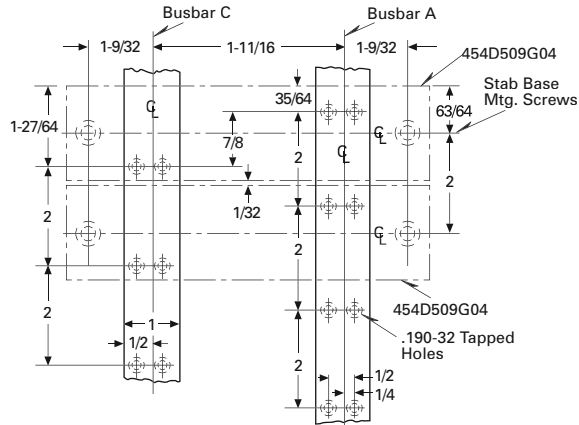

**Bus Bar Drilling for 3-Phase Panels**

For Two Breakers per Load Circuit (1/4 x 1 Copper Bus not Supplied)

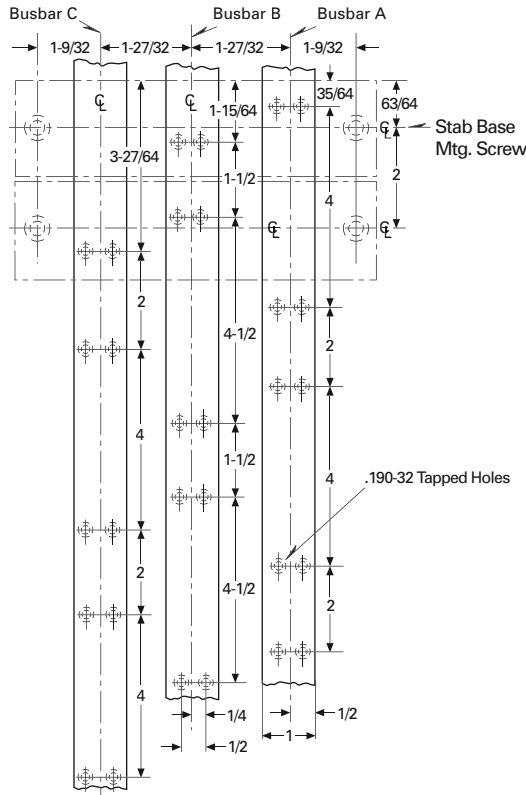

**FRONT VIEW**

# Types ALB-1 and NLB-1

## Outline Dimensions ALB-1 Breaker and Mounting Bases — Dimensions in Inches, Continued

### Application in dc and Single-Phase Panels

(Two Separate Bases shown. Basic Pattern is One Molded Base Accommodating Four Single-Pole Breakers)

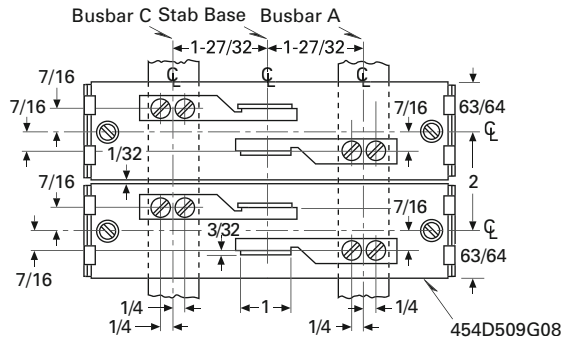

**FRONT VIEW**

### 3-Phase Panel Application for Two Breakers Per Load Circuit

(Basic Pattern of Three Separate Molded Bases can be Repeated for Longer Panel Boards)

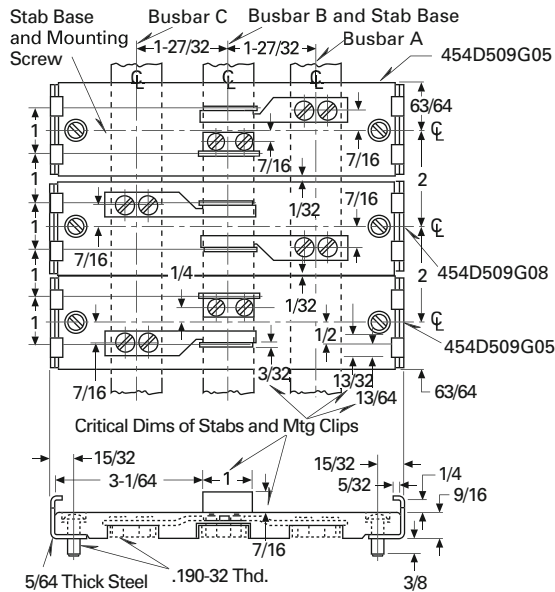

**SIDE VIEW**

### Outline Dimensions for Mounting Bases 454D509G05 or 454D509G08

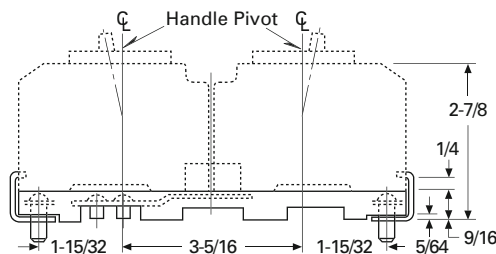

**SIDE VIEW**

### Bus Bar Drilling for dc and Single-Phase Panels

(1/4 x 1 Copper Bus not Supplied)

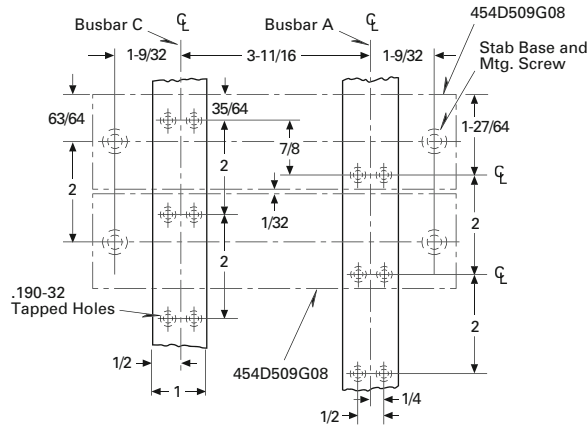

### Bus Bar Drilling for 3-Phase Panels

For Two Breakers per Load Circuit (1/4 x 1 Copper Bus not Supplied)

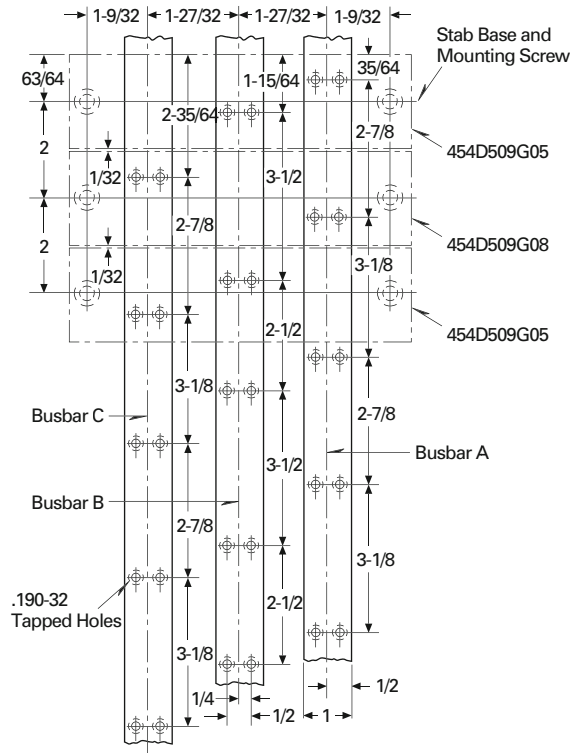

### Outline Dimensions for Mounting Bases 454D509G05 or 454D509G08

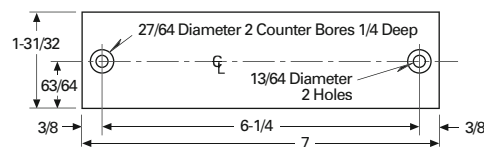

# Types ALB-1 and NLB-1

## Outline Dimensions ALB-1 Breaker and Mounting Bases — Dimensions in Inches, Continued

### 3-Phase Panel Application

(For One or Three Breakers per  
Load Circuit)

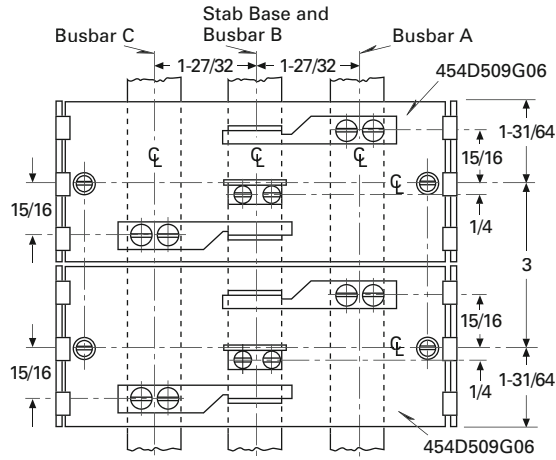

## Outline Dimensions for Mounting Base 454D509G06

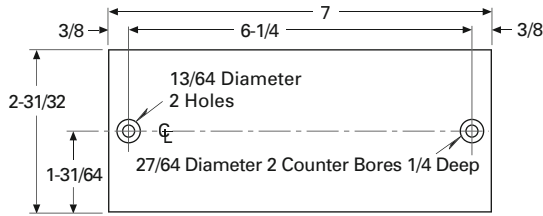

## Outline Dimensions for Mounting Bases 454D509G04, 454D509G05, 454D509G06, 454D509G08

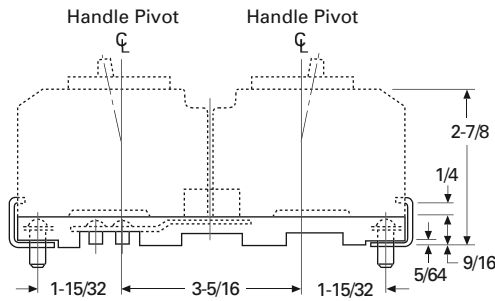

**SIDE VIEW**

### Bus Bar Drilling for 3-Phase Panel Application

For One or Three Breakers per Load Circuit (1/4 x 1 Copper Bus not Supplied)

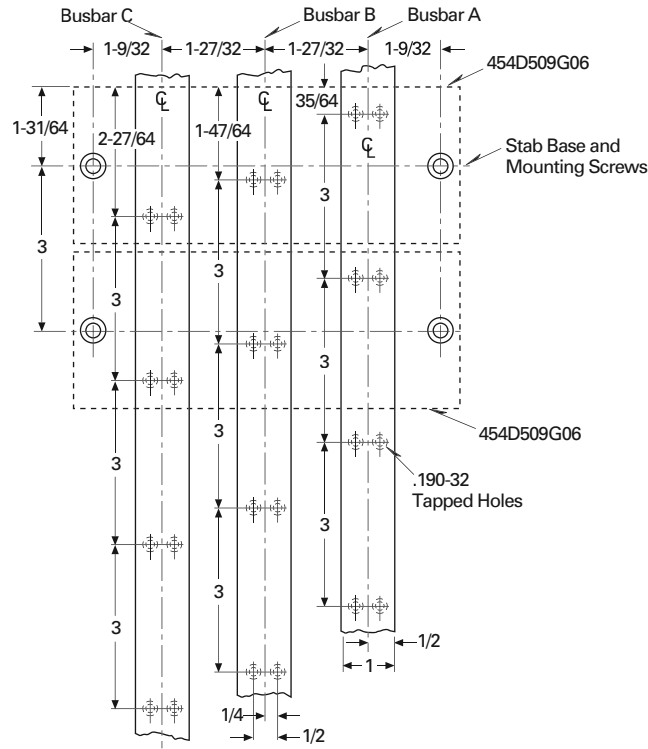

**FRONT VIEW**

### Front Panel Cutout

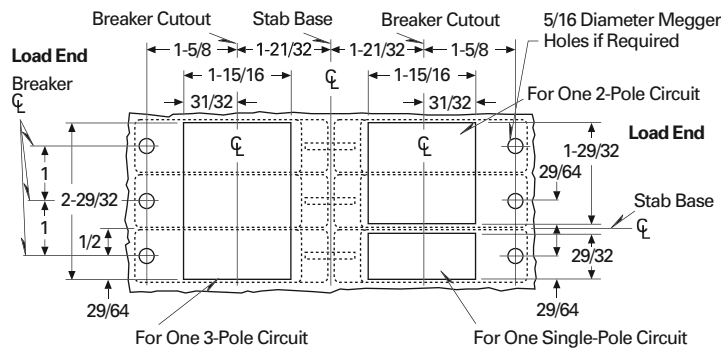



# Types ALB-1 and NLB-1

## Characteristic Time-Current Curve ALB-1 Breaker

### MIL-C-17588

This specification includes the ALB-1 type circuit breaker. It requires that this breaker carry 115% of current ratings for more than one hour and that the primary elements initiate tripping at 138% rated current within one hour and at 200% in 10 to 100 seconds. A tripping characteristic of the primary element is based on the current flowing through all poles in series and in an ambient of 50°C. The minimum instantaneous trip setting shall be 320 amperes or 20 times the element rating, whichever is less, and trip at not less than 0.5 cycles. At 800 amperes, the breaker must trip at 0.400 second or less.

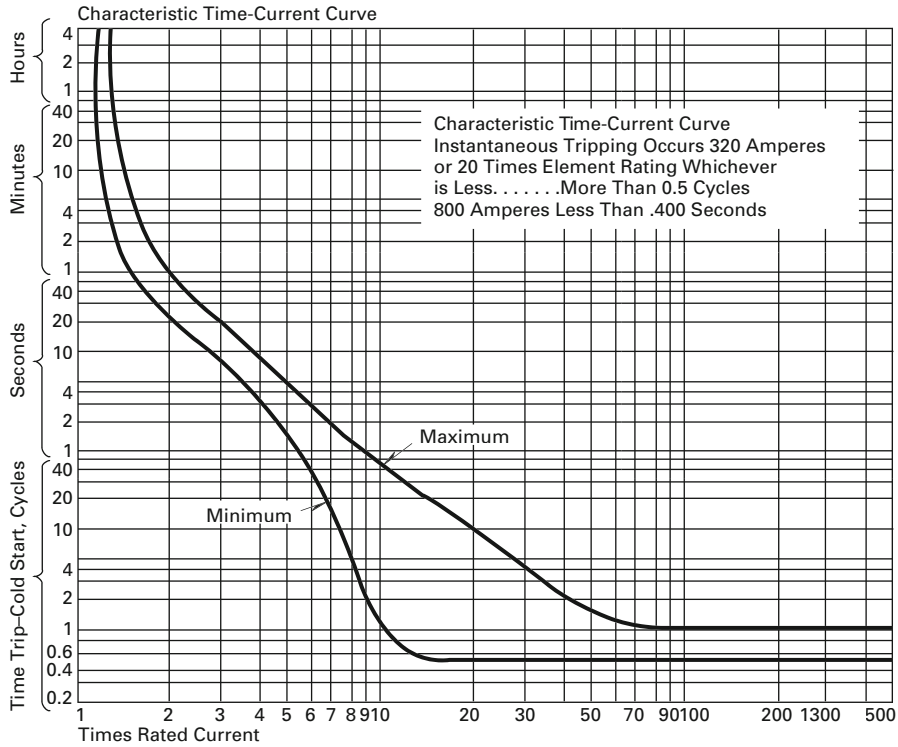

## Characteristic Temperature-Rating Curve

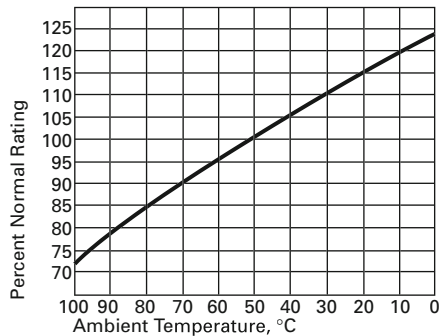

## Wiring Diagram

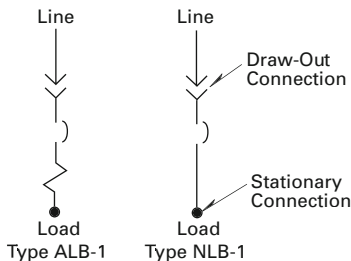

# Types AQB-A50, NQB-A50

## Circuit Breakers for Naval Shipboard Use — Types AQB-A50, NQB-A50 Breakers

500 Vac, 50 Amperes Maximum,  
5000 Amperes I.C.



### Specification: MIL-C-17361

- 10 – 50 amperes, 60 and 400 cycle.
- 500 volts ac.
- 3-pole.

### Interrupting Rating

- 5,000 amperes ac.
- Non-interchangeable trip unit.
- Class Hi-Shock MIL-S-901, 50°C ambient.

The AQB-A50 is a factory calibrated non-adjustable thermal-magnetic circuit breaker. The circuit breaker is assembled as

a 3-pole device with circuit protecting trip elements in the two outside poles. The unit can be installed in 2-pole applications by connecting the 2-wire circuit to the outside protected poles.

The NQB-A50 breaker is a non-automatic design of the AQB-A50. Since the tripping elements are omitted, it is used as a manual

disconnect. The NQB-A50 has a maximum continuous current rating of 50 amperes.

### Drawings Available

1244C62 – Master drawing for breaker and mounting bases.

### AQB-A50 AND NQB-A50 CIRCUIT BREAKER PRODUCT SELECTION ①

TYPE ②③	TRIP UNIT RATING	STYLE NUMBER	NATIONAL STOCK NUMBER
<b>60 Cycles</b>			
AQB-A50	10	<b>1244C52G01</b>	5925-01-188-4302
AQB-A50	15	<b>1244C52G02</b>	5925-01-188-6298
AQB-A50	20	<b>1244C52G03</b>	5925-00-799-5669
AQB-A50	25	<b>1244C52G04</b>	5925-00-797-9693
AQB-A50	30	<b>1244C52G05</b>	5925-01-225-1962
AQB-A50	35	<b>1244C52G06</b>	5925-01-251-3455
AQB-A50	40	<b>1244C52G07</b>	5925-01-234-7187
AQB-A50	50	<b>1244C52G08</b>	5925-01-331-8636
<b>400 Cycles</b>			
AQB-A50	10H	<b>1244C52G09</b>	5925-01-242-7456
AQB-A50	15H	<b>1244C52G10</b>	5925-01-240-9180
AQB-A50	20H	<b>1244C52G11</b>	5925-01-246-0471
AQB-A50	25H	<b>1244C52G12</b>	5925-01-234-6910
AQB-A50	30H	<b>1244C52G13</b>	5925-00-199-9518
AQB-A50	35H	<b>1244C52G14</b>	5925-01-234-6911
AQB-A50	40H	<b>1244C52G15</b>	5925-00-817-7860
AQB-A50	50H	<b>1244C52G16</b>	5925-01-234-6912
NQB-A50	Non-Automatic	<b>1244C52G25</b>	5925-00-948-3296

① For list prices, see Price and Availability Digest (PAD).

② Complete breaker does not include mounting bases. Type required must be ordered separately. Mounting bases include cable lugs.

③ Only 3-pole breakers furnished; for 2-pole application make connections to outside poles.

Refer to Eaton for dc Part Numbers and Information.

### Note:

These breakers are non-repairable per NAVSEA letter, serial number 9077 Ser 03/03 EI-48, paragraph 3 Policy, sub-paragraph 2, dated 25 October 1994.

# Types AQB-A50, NQB-A50

## PANELBOARD MOUNTING AND ACCESSORIES

TYPE	STYLE NUMBER	NATIONAL STOCK NUMBER
Single Base — Line and Load Stabs, Front Connected	<b>1244C44G01</b>	5925-00-270-4004
Single Base — Line and Load Stabs, Rear Connected	<b>1244C44G02</b>	5925-00-270-4005
Single Base — Line Rear, Load Front Connected	<b>1244C44G03</b>	5925-00-270-4006
Double Base Assembly — Line, Bus Connected; Load, Front Connected	<b>1244C45G01</b>	5925-01-246-0569
Handle Lock	<b>5080A95G01</b>	—
Handle Boot	<b>752B729H01</b>	5340-01-091-9432
Technical Manual	<b>1244C59H01</b>	—

## NET WEIGHT

DESCRIPTION	NET WEIGHT, LBS. (KG)
AQB-A50 Breaker	2.3 (1.0)
NQB-A50 Breaker	1.9 (0.9)
Single Mounting Base	0.7 (0.3)
Double Mounting Base	1.5 (0.7)
Handle Lock	.03 (0.01)

For ordering information, see **Page 5**.



**AQB-A50 SINGLE MOUNTING BASE — FRONT CONNECTED**



**AQB-A50 SINGLE MOUNTING BASE — REAR CONNECTED**



**SINGLE BASE LINE STABS REAR CONNECTED — LOAD STABS FRONT CONNECTED**



**HANDLE LOCK**



**DOUBLE MOUNTING BASE — FRONT CONNECTED**

**Outline Dimensions AQB-A50 and NQB-A50 Breakers**  
**— Dimensions in Inches**

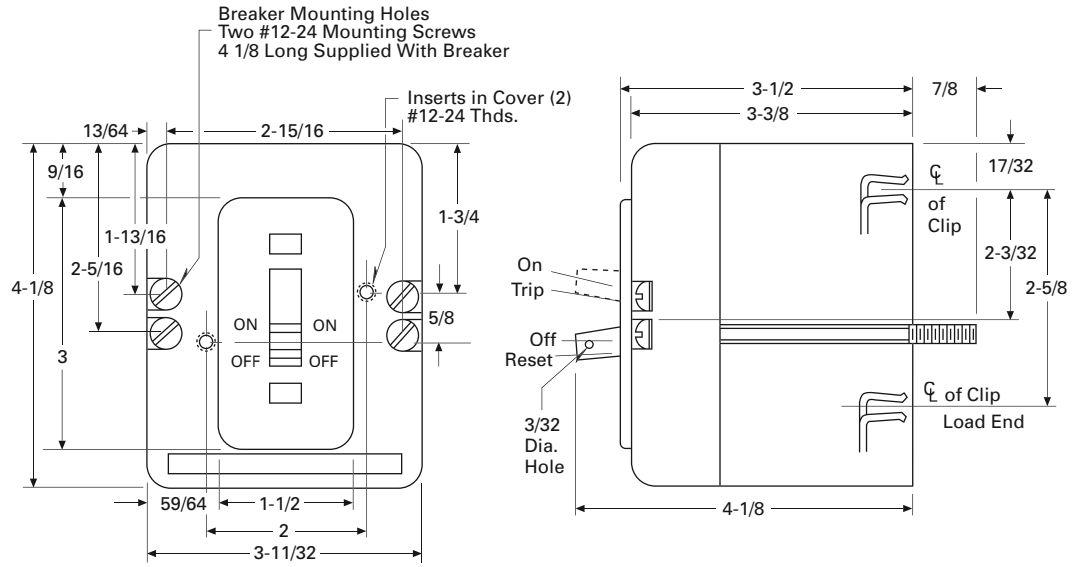

**Front Panel Cutout**

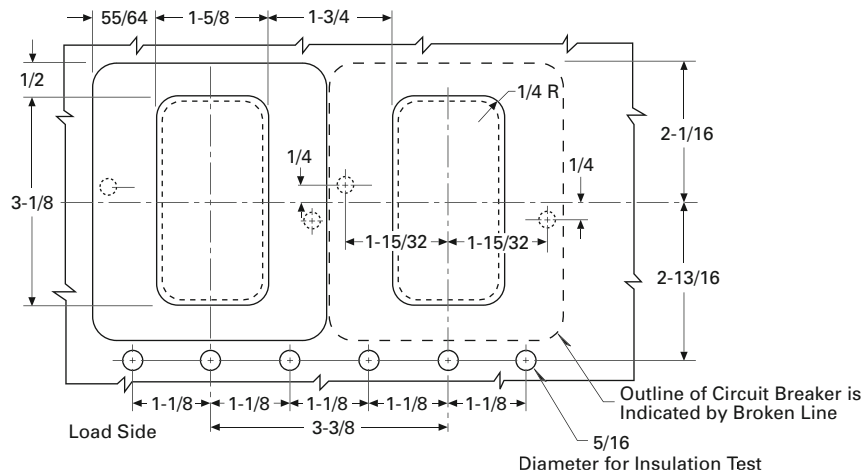

**Wiring Diagram**

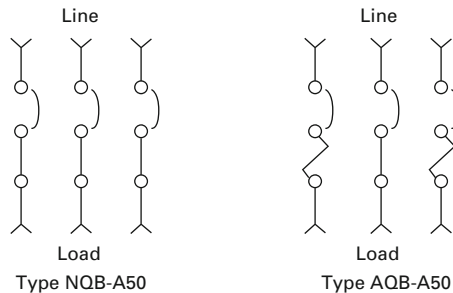

# Types AQB-A50, NQB-A50

## Outline Dimensions Single Base Units — Dimensions in Inches

### Line and Load Stabs Front Connected

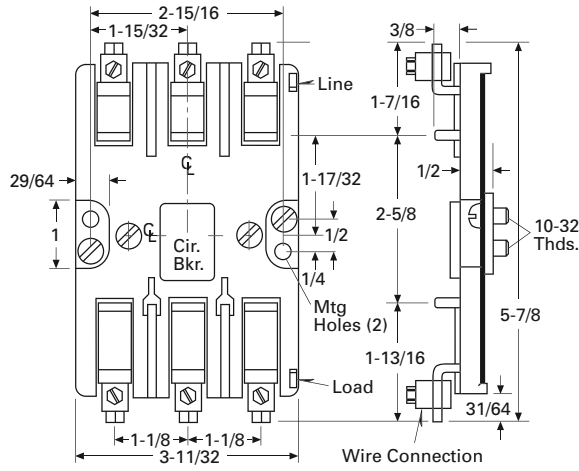

### Line and Load Stabs Back Connected

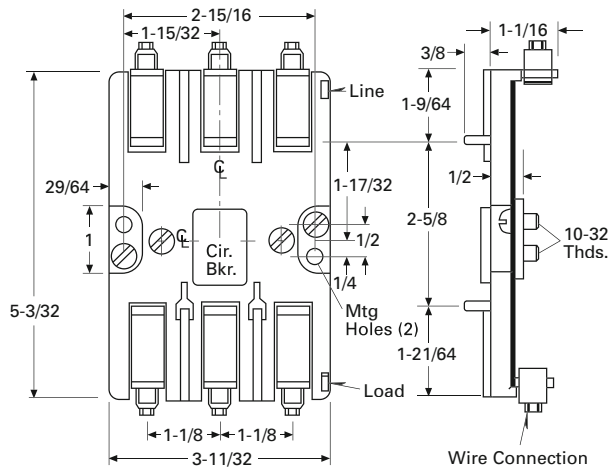

### Line Stabs Back Connected, Load Sides Front Connected

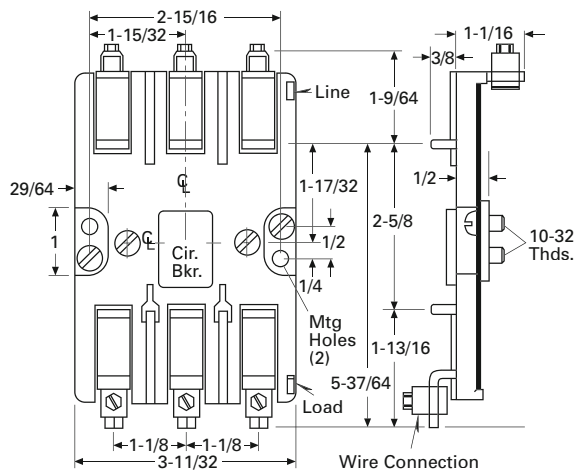

**Outline Dimensions  
Double Base Assembly —  
Panelboard — Dimensions  
in Inches**

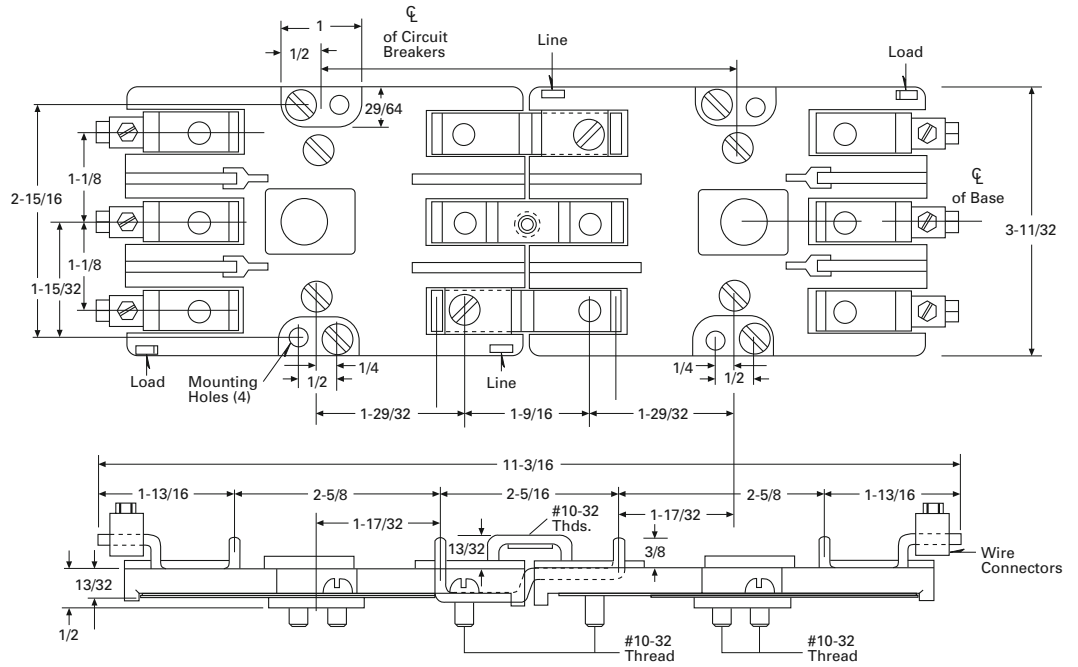

**LINE BUS CONNECTED, LOAD FRONT CONNECTED**

# Types AQB-A50, NQB-A50

## Characteristic Time-Current Curve Navy Type AQB-A50 Circuit Breaker

Time-Current Curves for  
AQB-A50 Circuit Breaker  
(60 Hz and 400 Hz — 10, 15,  
20, 25, 30, 35, 40 and 50  
Ampere Ratings)

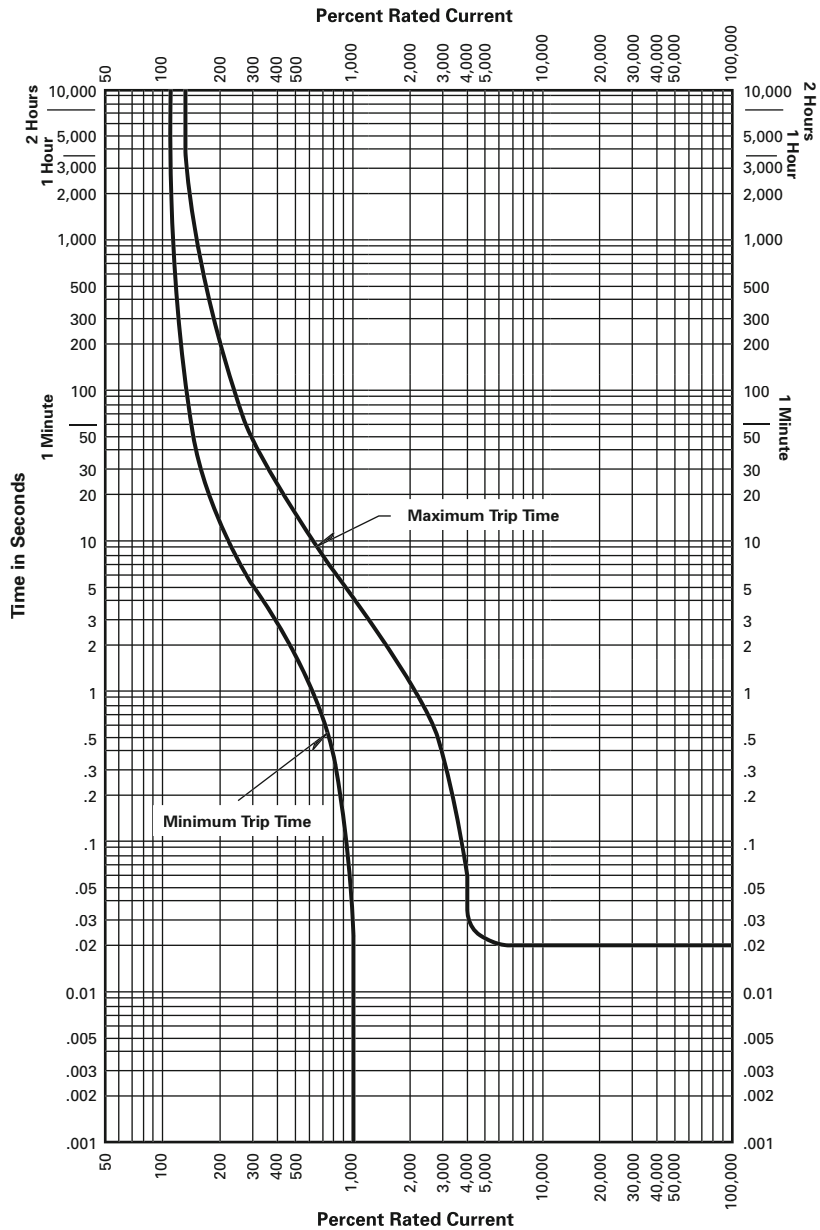

# Types AQB-A51, NQB-A51

## Circuit Breakers for Naval Shipboard Use — Types AQB-A51, NQB-A51 Breakers

500 Vac, 50 Amperes Maximum, 5000 Amperes I.C.



### Specification: MIL-C-17361

- 10 – 50 amperes, 60 cycles.
- 500 volts ac.
- 3-pole.

### Interrupting Rating

- 5,000 amperes I.C.
- Non-Interchangeable trip unit.
- Class Hi-Shock MIL-S-901, 50°C ambient.

The Type AQB-A51 molded case circuit breaker is a 500 Vac maximum rated device with 50 ampere maximum continuous current at 60 Hz. The AQB-A51 is a form, fit and function replacement for the AQB-A50 circuit breaker with enhanced overcurrent protection features. In the

AQB-A51, overcurrent protection is provided in all three poles. This not only makes the breaker suitable for use in “grounded” three-phase systems, but offers enhanced performance of the instantaneous trip feature when used in ungrounded systems. In three phase distribution systems with either a solidly or “effectively” grounded neutral, fault currents can occur that will be evident in only one pole, so protection is needed in all three poles. The enhanced instantane-

ous trip feature is valuable in the selective coordination of the AQB-A51 with upstream AQB breakers. The AQB-A51 circuit breaker has an interruption rating of 5000 amperes asymmetric.

The NQB-A51 breaker is a non-automatic design of the AQB-A51. Since the tripping elements are omitted, it is used as a manual disconnect. The NQB-A51 has a maximum continuous current rating of 50 amperes.

### AQB-A51 AND NQB-A51 CIRCUIT BREAKER PRODUCT SELECTION ①

TYPE ②	TRIP UNIT RATING	STYLE NUMBER	NATIONAL STOCK NUMBER
<b>60 Cycles</b>			
AQB-A51	10	<b>1244C56G01</b>	5925-01-511-0205
AQB-A51	15	<b>1244C56G02</b>	5925-01-458-3739
AQB-A51	20	<b>1244C56G03</b>	5925-01-461-1628
AQB-A51	25	<b>1244C56G04</b>	5925-01-511-0208
AQB-A51	30	<b>1244C56G05</b>	5925-01-511-1210
AQB-A51	35	<b>1244C56G06</b>	5925-01-511-0214
AQB-A51	40	<b>1244C56G07</b>	5925-01-511-0217
AQB-A51	50	<b>1244C56G08</b>	5925-01-511-0220
NQB-A51	Non-Automatic	<b>1244C56G25</b>	—

① For list prices, see Price and Availability Digest (PAD).

② Complete breaker does not include mounting bases. Type required must be ordered separately. Mounting bases include cable lugs.

### Note:

These breakers are non-repairable per NAVSEA letter, serial number 9077 Ser 03/03 EI-48, paragraph 3 Policy, sub-paragraph 2, dated 25 October 1994.



# Types AQB-A51, NQB-A51

## PANELBOARD MOUNTING AND ACCESSORIES

TYPE	STYLE NUMBER	NATIONAL STOCK NUMBER
Single Base — Line and Load Stabs, Front Connected	<b>1244C44G01</b>	5925-00-270-4004
Single Base — Line and Load Stabs, Rear Connected	<b>1244C44G02</b>	5925-00-270-4005
Single Base — Line Rear, Load Front Connected	<b>1244C44G03</b>	5925-00-270-4006
Double Base Assembly — Line, Bus Connected; Load, Front Connected	<b>1244C45G01</b>	5925-01-246-0569
Handle Lock	<b>5080A95G01</b>	—
Handle Boot	<b>752B729H01</b>	5340-01-091-9432
Technical Manual	<b>1244C59H01</b>	—

## NET WEIGHT

DESCRIPTION	NET WEIGHT, LBS. (KG)
AQB-A51 Breaker	2.4 (1.1)
NQB-A51 Breaker	1.9 (0.9)
Single Mounting Base	0.7 (0.3)
Double Mounting Base	1.5 (0.7)
Handle Lock	.03 (0.01)

For ordering information, see **Page 5**.



**AQB-A51 SINGLE MOUNTING BASE — FRONT CONNECTED**



**AQB-A51 SINGLE MOUNTING BASE — REAR CONNECTED**



**SINGLE BASE LINE STABS REAR CONNECTED — LOAD STABS FRONT CONNECTED**



**HANDLE LOCK**



**DOUBLE MOUNTING BASE — FRONT CONNECTED**

**Outline Dimensions AQB-A51 and NOB-A51 Breakers**  
**— Dimensions in Inches**

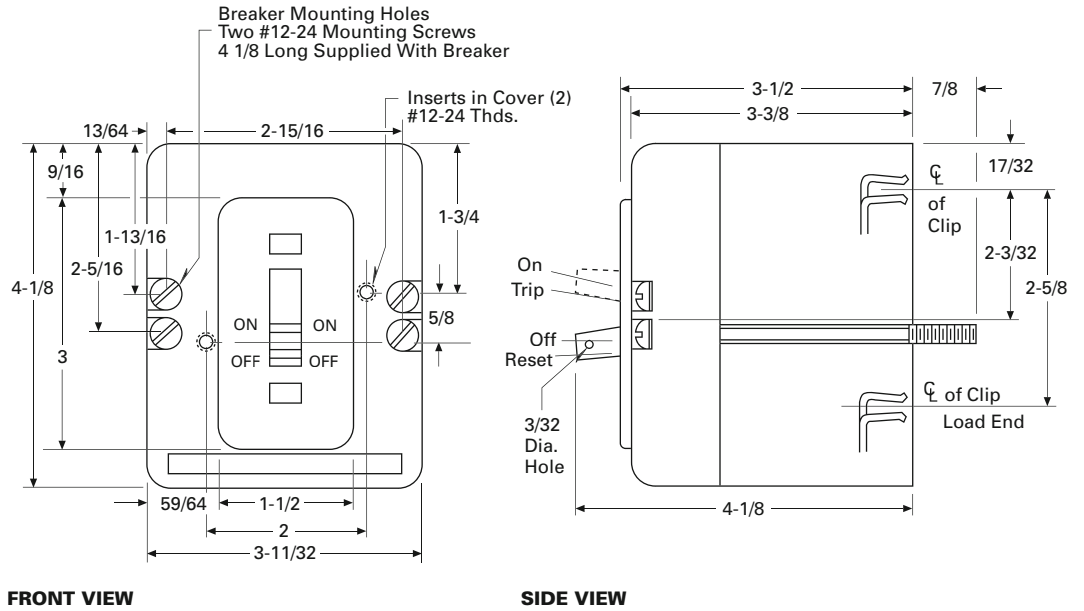

**Front Panel Cutout**

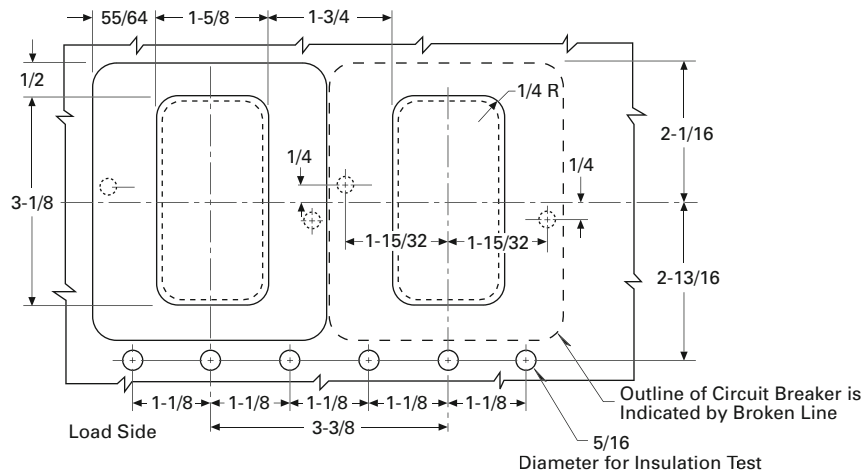

**Wiring Diagram**

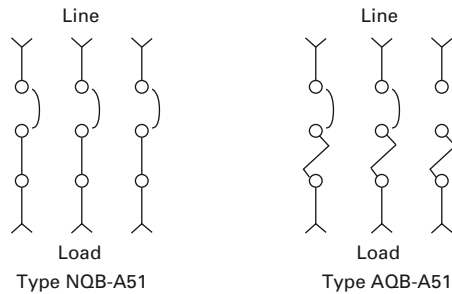

# Types AQB-A51, NQB-A51

## Outline Dimensions Single Base Units — Dimensions in Inches

### Line and Load Stabs Front Connected

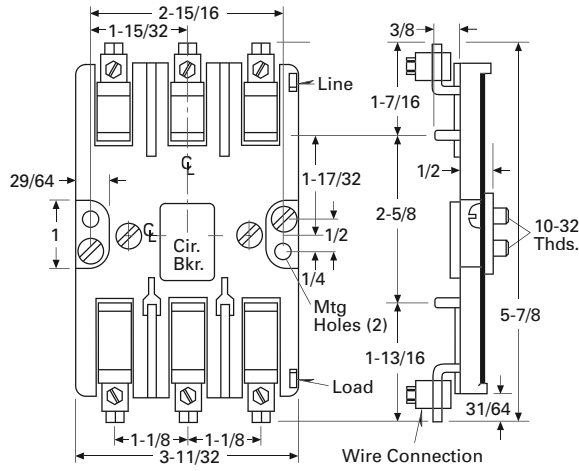

### Line and Load Stabs Back Connected

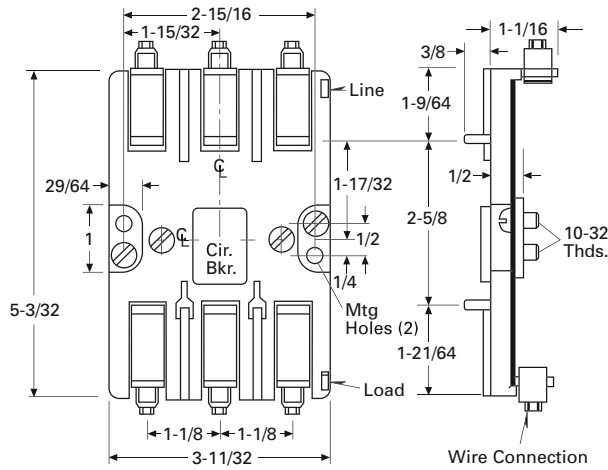

### Line Stabs Back Connected, Load Sides Front Connected

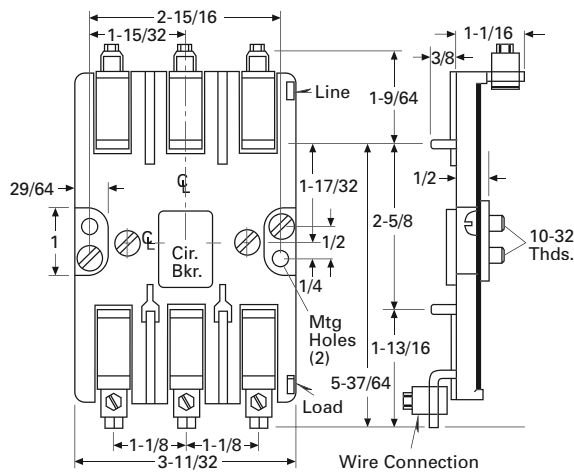

**Outline Dimensions Double  
Base Assembly — Panelboard  
— Dimensions in Inches**

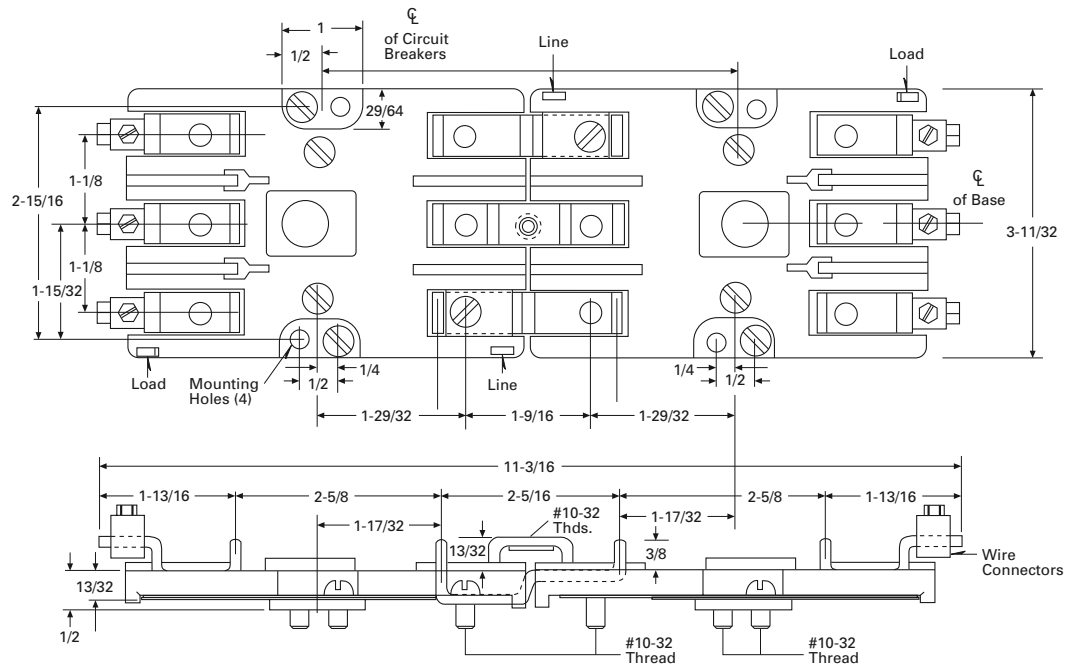

**LINE BUS CONNECTED, LOAD FRONT CONNECTED**

# Types AQB-A51, NQB-A51

## Characteristic Time-Current Curve Navy Type AQB-A51 Circuit Breaker

### Time-Current Curves for AQB-A51 Circuit Breaker (60 Hz)

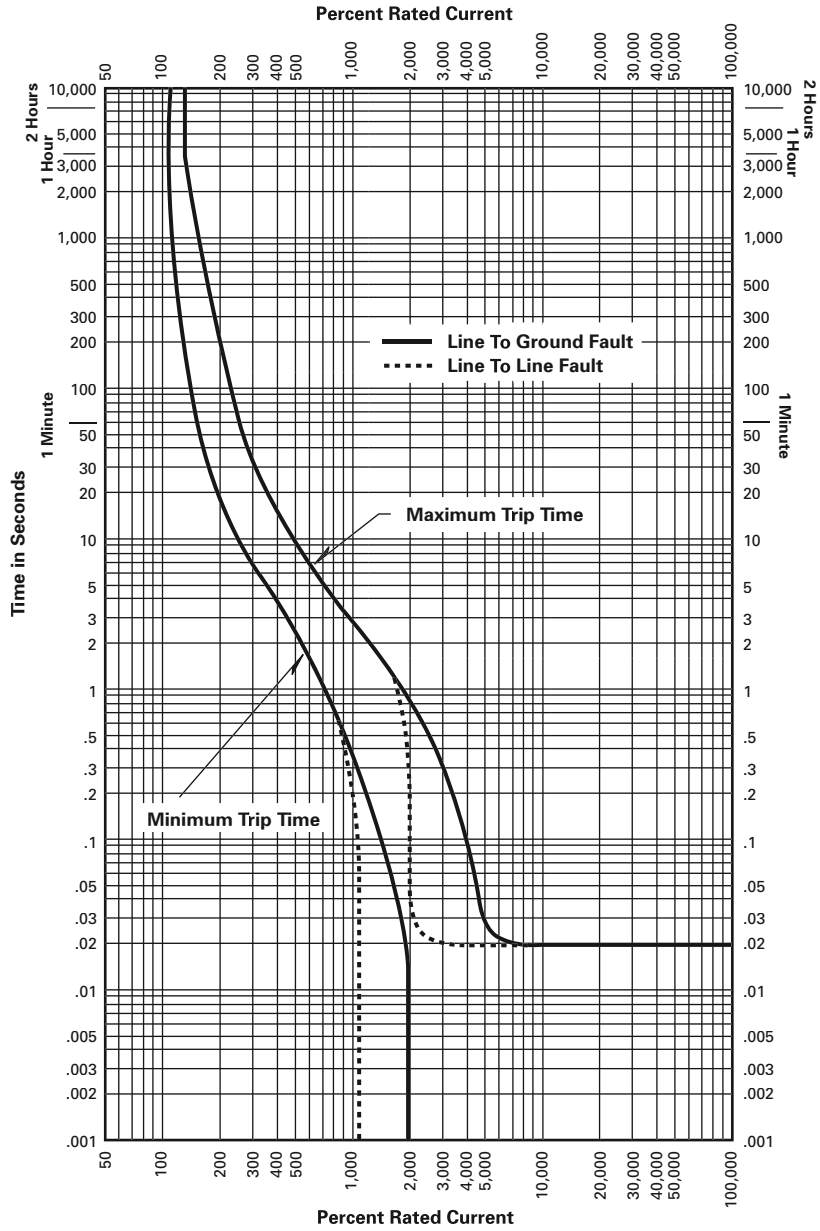

**Note:** Line to Ground fault is single-phase. Line to Line fault is three-phase.

# Types AQB-A100, NQB-A100

## Circuit Breakers for Naval Shipboard Use — Types AQB-A100, NQB-A100 Breakers

250 Volts dc, 500 Volts ac, 100 Amperes Maximum, 15,000 Amperes ac, 10,000 Amperes dc I.C.

### Note:

AQB-A100 and NQB-A100 breakers are sold for replacement only. They are no longer on the Navy Qualified Product List.



**AQB-A100**

### Specification: MIL-C-17361

- 15 – 100 amperes.
- 500 volts ac and 250 volts dc.
- 2- or 3-pole.

### Interrupting Rating

- 15,000 amperes ac and 10,000 amperes dc.

AQB-A100 circuit breakers are designed for use in lighting and distribution panelboards and switchboards for the protection of feeder and motor branch circuits.

Trip units with current ratings of 15, 25, 50, 75 and 100 can be quickly interchanged and a conversion kit is available to change a 3-pole, 500 volt AQB-A100 to a nonautomatic NQB-A100 circuit interrupter. NQB-A100 breakers have a maximum continuous

current rating of 100 amperes, but they are used only as disconnects since there is no automatic opening device.

Those breakers (and interrupters) designed for dc motor circuits and for ac feeder circuits (designated with a “BF” in amp rating column of price table) have fixed instantaneous settings of 600% – 700% continuous current ratings. Those having a magnetic element set to trip at 1200% – 1400% are applied on ac motor circuits (designated with a “B”). Breakers designated with “BE” are calibrated for dc application.

## AQB-A100 AND NQB-A100 CIRCUIT BREAKER PRODUCT SELECTION ①

CONTINUOUS AMPERE RATING	INSTANTANEOUS TRIP SETTING IN AMPERES		COMPLETE BREAKER ②		BREAKER FRAME ONLY ②		TRIP UNIT ONLY	
	LOW	HIGH	STYLE NUMBER	NATIONAL STOCK NUMBER	STYLE NUMBER	NATIONAL STOCK NUMBER	STYLE NUMBER	NATIONAL STOCK NUMBER
<b>2-Pole, 250 Volts dc</b>								
15-BE	90	105	<b>1764 676</b>	—	<b>1764 638</b>	—	<b>1764 640</b>	—
25-BE	150	175	<b>1764 677</b>	5925-01-221-1765	<b>1764 638</b>	—	<b>1764 641</b>	5925-00-248-1104
50-BE	300	350	<b>1764 678</b>	—	<b>1764 638</b>	—	<b>1764 642</b>	—
75-BE	450	525	<b>1764 679</b>	—	<b>1764 638</b>	—	<b>1764 643</b>	5925-00-248-1108
100-BE	600	700	<b>1764 680</b>	—	<b>1764 638</b>	—	<b>1764 644</b>	—
<b>2-Pole, 500 Volts ac</b>								
15-BF	90	105	<b>1764 681</b>	—	<b>1764 638</b>	—	<b>1764 645</b>	—
15-B	180	210	<b>1764 682</b>	5925-00-396-2283	<b>1764 638</b>	—	<b>1764 646</b>	5925-00-629-0975
25-BF	150	175	<b>1764 683</b>	—	<b>1764 638</b>	—	<b>1764 647</b>	—
25-B	300	350	<b>1764 684</b>	—	<b>1764 638</b>	—	<b>1764 648</b>	5925-00-628-0695
50-B	600	700	<b>1764 685</b>	—	<b>1764 638</b>	—	<b>1764 649</b>	5925-00-248-1078
75-B	900	1050	<b>1764 686</b>	—	<b>1764 638</b>	—	<b>1764 650</b>	5925-00-248-1082
100-B	1200	1400	<b>1764 687</b>	—	<b>1764 638</b>	—	<b>1764 651</b>	—
100 ③	Non-Automatic		<b>1764 688</b>	5925-00-699-1111	<b>1764 638</b>	—	<b>1764 652</b>	5925-00-772-0646
<b>3-Pole, 250 Volts dc</b>								
15-BE	90	105	<b>1764 689</b>	—	<b>1764 639</b>	5925-00-258-2945	<b>1764 653</b>	5925-00-608-0972
25-BE	150	175	<b>1764 690</b>	5925-00-399-8120	<b>1764 639</b>	5925-00-258-2945	<b>1764 654</b>	5925-00-553-9745
50-BE	300	350	<b>1764 691</b>	—	<b>1764 639</b>	5925-00-258-2945	<b>1764 655</b>	5925-00-383-3814
75-BE	450	525	<b>1764 692</b>	—	<b>1764 639</b>	5925-00-258-2945	<b>1764 656</b>	5925-00-248-1371
100-BE	600	700	<b>1764 693</b>	5925-00-399-8127	<b>1764 639</b>	5925-00-258-2945	<b>1764 657</b>	5925-00-608-0973

① For list prices, see Price and Availability Digest (PAD).

② Styles listed include slip-type connectors for rear connections. Order front terminal connectors separately if required. No additional charges for front connectors ordered with breakers or frames.

③ Type NQB-A100 non-automatic. To convert 3-pole AQB breaker, order style 1764 668 only.

### Note:

Breakers with ratings other than those given on this page are considered special and full description data must be provided.

# Types AQB-A100, NQB-A100

## AQB-A100 AND NQB-A100 CIRCUIT BREAKER PRODUCT SELECTION, CONTINUED <sup>①</sup>

CONTINUOUS AMPERE RATING	INSTANTANEOUS TRIP SETTING IN AMPERES		COMPLETE BREAKER		BREAKER FRAME ONLY <sup>②</sup>		TRIP UNIT ONLY	
	LOW	HIGH	STYLE NUMBER	NATIONAL STOCK NUMBER	STYLE NUMBER	NATIONAL STOCK NUMBER	STYLE NUMBER	NATIONAL STOCK NUMBER
<b>3-Pole, 500 Volts ac</b>								
15-BF	90	105	<b>1764 694</b>	5925-00-113-5066	<b>1764 639</b>	5925-00-258-2945	<b>1764 658</b>	5925-00-502-6719
15-B	180	210	<b>1764 695</b>	—	<b>1764 639</b>	5925-00-258-2945	<b>1764 659</b>	5925-00-248-1453
25-BF	150	175	<b>1764 696</b>	5925-00-658-9609	<b>1764 639</b>	5925-00-258-2945	<b>1764 660</b>	5925-00-215-3758
25-B	300	350	<b>1764 697</b>	5925-00-265-9474	<b>1764 639</b>	5925-00-258-2945	<b>1764 661</b>	5925-00-248-1449
50-BF	300	350	<b>1764 698</b>	5925-00-988-5474	<b>1764 639</b>	5925-00-258-2945	<b>1764 662</b>	5925-00-248-1442
50-B	600	700	<b>1764 699</b>	5925-00-396-2339	<b>1764 639</b>	5925-00-258-2945	<b>1764 663</b>	5925-00-248-1443
75-BF	450	525	<b>1764 700</b>	—	<b>1764 639</b>	5925-00-258-2945	<b>1764 664</b>	5925-00-248-1436
75-B	900	1050	<b>1764 701</b>	5925-00-396-2345	<b>1764 639</b>	5925-00-258-2945	<b>1764 665</b>	5925-00-248-1437
100-BF	600	700	<b>1764 702</b>	5925-01-265-0190	<b>1764 639</b>	5925-00-258-2945	<b>1764 666</b>	5925-00-248-1429
100-B	1200	1400	<b>1764 703</b>	5925-00-450-6275	<b>1764 639</b>	5925-00-258-2945	<b>1764 667</b>	5925-00-248-1431
100 <sup>③</sup>	Non-Automatic		<b>1764 704</b>	5930-01-300-1107	<b>1764 639</b>	5925-00-258-2945	<b>1764 668</b>	5925-00-699-1111

<sup>①</sup> For list prices, see Price and Availability Digest (PAD).

<sup>②</sup> Styles listed include slip-type connectors for rear connections. Order front terminal connectors separately if required. No additional charges for front connectors ordered with breakers or frames.

<sup>③</sup> Type NQB-A100 non-automatic. To convert 3-pole AQB breaker, order style 1764 668 only.

### Note:

Breakers with ratings other than those given on this page are considered special and full description data must be provided.

### Front Connected Breakers

For the load ends of panelboard breakers and for other front terminal applications, pressure connectors should be ordered.

When breakers and the required lugs are ordered simultaneously, these lugs will be supplied without charge.

CABLE RANGE	NAVY CABLE SIZE, MAXIMUM ①	DESCRIPTION	STYLE NUMBER	NATIONAL STOCK NUMBER
N3-N14	14,340	One Pressure Connector	1763 660	—
N23-N40	38,910	One Pressure Connector	1763 661	—
N50-N75	75,780	One Pressure Connector	1763 662	—

① Circular MILs area.

### Switchboard Mounting

Complete breakers and frames include mounting hardware. Female slip connectors are mounted in the breaker base for

plugging onto stud projections of terminal mounting block assemblies. Order one mounting block assembly for each end of the breaker.

NUMBER OF POLES	DESCRIPTION	STYLE NUMBER	NATIONAL STOCK NUMBER
2	Mounting Block Assembly	1764 675	—
3	Mounting Block Assembly	1764 674	—
2 or 3	Mounting Block Only	1764 240	5940-00-643-7194
—	One Stud Assembly — Complete with 4 Nuts	1631 442	5940-00-501-9120

### NET WEIGHT, TERMINAL MOUNTING SUPPORTS (SET OF TWO)

MOUNTING BLOCK ASSEMBLY	NET WEIGHT, LBS. (KG)	FRAME	NET WEIGHT, LBS. (KG)
2-Pole	2.75 (1.2)	2-Pole AQB	7.38 (3.4)
		2-Pole NQB	7.38 (3.4)
3-Pole	3.25 (1.5)	3-Pole AQB	7.88 (3.6)
		3-Pole NQB	7.88 (3.6)

COMPLETE BREAKER	NET WEIGHT, LBS. (KG)	TRIP UNIT	NET WEIGHT, LBS. (KG)
2-Pole AQB	10.00 (4.5)	2-Pole AQB	2.63 (1.2)
2-Pole NQB	8.75 (4.0)	2-Pole NQB	1.38 (0.6)
3-Pole AQB	10.75 (4.9)	3-Pole AQB	2.88 (1.3)
3-Pole NQB	9.50 (4.3)	3-Pole NQB	1.63 (0.7)

For ordering information, see **Page 5**.

### Additions

#### Handle Lock

When specified, order style 1614 485. One furnished without charge per every 10 breakers, when requested.

NSN: 5930-00-669-7524

#### Fungus-Moisture Resistant Treatments

(JAN-T-152, JAN-C-173 or MIL-V-173) if specified, contact Eaton. External parts are coated; trip units are not treated.

#### Technical Manual Navships 362-0819- per MIL-M-15071

When required, specify IB-29-062-CIA.

### Individual Reproductions

When required, reproductions of master drawings, outline drawings and certification sheets can be ordered as follows:

ITEM	DESCRIPTION
1	Full size photolithographic tracing of master drawing on vellum
2	Outline and drilling plan on vellum
3	Certification data on vellum
4	Reproductions of Items 1, 2 or 3

### Drawings Available

Master drawing 1-JF-630; rear connected breaker outline, drilling and wiring diagram 20-B-2881; front connected breaker outline, drilling and wiring diagram 30-B-3837.

### 400 Cycle Breakers

Refer to Eaton.



# Types AQB-A100, NQB-A100

## Outline Dimensions AQB-A100 and NQB-A100 Breakers — Dimensions in Inches

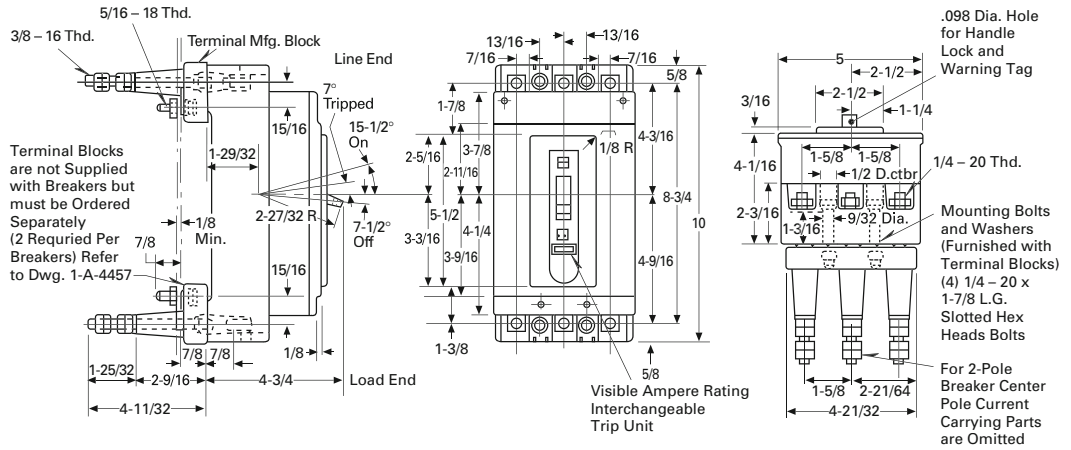

## Slip Contact Assembly

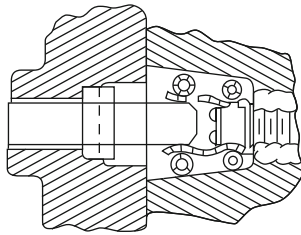

## Drilling Plan

For Mounting Panel (Front View)

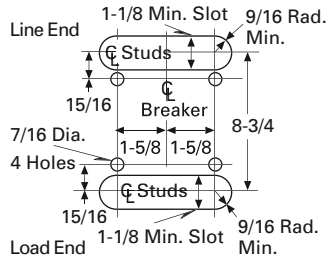

## Front Cover Cutout

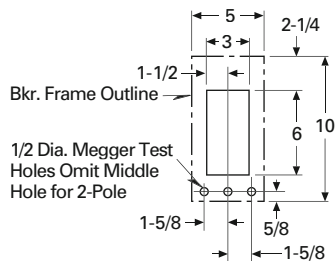

## Characteristic Time-Current Curves

### AQB-A100 Breakers

#### Operating Characteristics

Trip Unit Rating 15 – 100 Amperes  
50°C Ambient — Cold Start,  
60 Cycle, ac or dc.

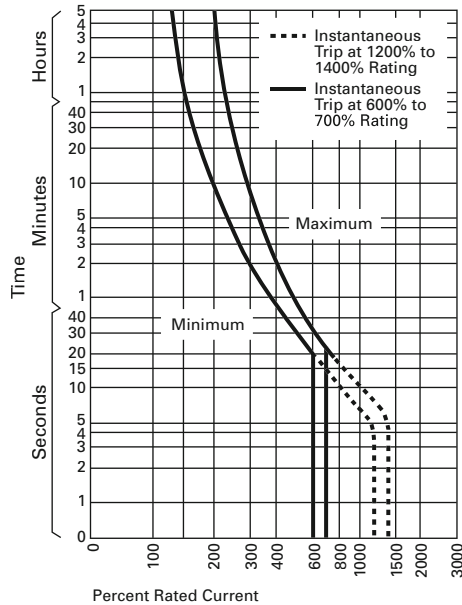

### 400 Cycle Breakers

#### Operating Characteristics

Trip Unit Rating 15 – 100 Amperes  
50°C Ambient — Cold Start  
400 Cycle ac.

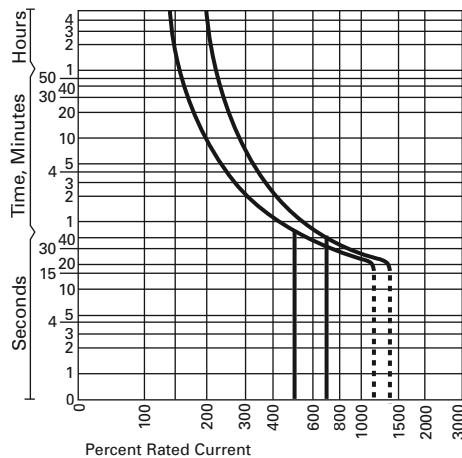

## Trip Unit Rating

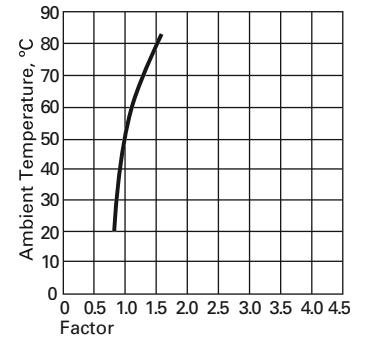

To determine the trip unit rating to be used, when the load current and ambient are known, multiply the load current by the factor obtained from this curve for the known ambient. The result will be the ideal trip unit rating. However, since trip units are furnished only with standard ratings as per Navy spec., select the standard trip unit whose rating is equal to or one rating higher than the ideal rating.

### Specification MIL-C-17361

This specification covers all thermal-magnetic AQB breakers. It requires that they carry 150% of current ratings for at least one hour and that thermal elements initiate tripping at 225% rated current within one hour and at 600% in 25 seconds plus or minus 25%. The instantaneous magnetic settings for each continuous ratings are based on intended applications. (Thermal tripping tests are conducted with all poles in series in 50°C ambient; each pole is tested individually to check magnetic settings.)

# Types AQB-A101, NQB-A101

## Circuit Breakers for Naval Shipboard Use — Types AQB-A101, NQB-A101 Breakers

250 Volts dc, 500 Volts ac, 100  
Amperes Maximum, 15,000  
Amperes ac, 10,000 Amperes  
dc I.C.



### Specification: MIL-C-17361

- 15 – 100 amperes.
- 500 volts ac and 250 volts dc.
- 3-pole.

### Interrupting Rating

- 15,000 amperes ac and 10,000 amperes dc.
- Non-Interchangeable Trip Unit.
- Class: Hi Shock MIL-S-901: 50°C Ambient.

AQB-A101 circuit breakers are designated for use in lighting and distribution panelboards and for switchboards in the protection of feeder and motor branch circuits.

These breakers have adjustable instantaneous trip settings of “LO,” “Intermediate,” and “HI.” The “LO” setting is 500% — 700% of continuous current rating. It is designed for dc motor circuits and ac feeder circuits.

The “HI” setting is 1200% — 1400% of continuous current rating and is designed for application on ac motor circuits. The intermediate setting may be used to increase LO setting trip amperes or decrease HI setting trip amperes as may be required.

NQB-A101 circuit breakers have a maximum continuous current rating of 100 amperes. They are used only as disconnects, since they do not include an automatic opening device.

### Generator Breakers

(Designated with a “G”) are also available in other configurations. Consult Eaton.

## AQB-A101 AND NQB-A101 CIRCUIT BREAKER PRODUCT SELECTION ①

TYPE ②③④	TRIP UNIT AMPERE RATING	INSTANTANEOUS TRIP SETTING ⑤ AC 60 CYCLES		THERMAL MAGNETIC STYLE NUMBER	NATIONAL STOCK NUMBER	MAGNETIC ONLY STYLE	NATIONAL STOCK NUMBER
		HI	LO				
AQB-A101	15	180 – 210	75 – 105	458D509G11	5925-00-876-9216	458D511G11	5925-00-397-8258
AQB-A101	25	300 – 350	125 – 175	458D509G12	5925-00-876-9217	458D511G12	—
AQB-A101	50	600 – 700	250 – 350	458D509G13	5925-00-876-9218	458D511G13	5925-00-546-3258
AQB-A101	75	900 – 1050	375 – 525	458D509G14	5925-01-136-5633	458D511G14	—
AQB-A101	100	1200 – 1400	500 – 700	458D509G15	5925-00-876-9220	458D511G15	5925-01-022-5086
AQB-A101 ⑥	100G ⑦	1200 – 1400	500 – 700	458D509G16	5925-00-619-0412	—	—
NQB-A101	100	Non-Automatic	—	458D509G20	5930-00-969-2477	—	—
<b>400 Cycle</b>							
AQB-A101	15H	180 – 210	75 – 105	458D510G11	5925-00-867-7328	458D512G11	—
AQB-A101	25H	300 – 350	125 – 175	458D510G12	5925-00-867-7329	458D512G12	—
AQB-A101	50H	600 – 700	250 – 350	458D510G13	5925-00-986-7313	458D512G13	—
AQB-A101	75H	900 – 1050	375 – 525	458D510G14	5925-00-986-7314	458D512G14	—
AQB-A101	100H	1200 – 1400	500 – 700	458D510G15	5925-00-972-3000	458D512G15	—
AQB-A101	100GH ⑦	1200 – 1400	500 – 700	458D510G16	5925-01-200-7813	—	—

① For list prices, see Price and Availability Digest (PAD).

② Complete breaker does not include mounting bases. Type required must be ordered separately.

③ Front connected bases include cable lugs. Cover cable sizes 2828CM to 100,000CM.

④ Only 3-pole breakers are furnished, for 2-pole applications make connections to outside poles.

⑤ Instantaneous trip setting at 1200 – 1400% HI or 500 – 700% LO. Set at LO position at factory.

⑥ Manufactured to meet MIL-C 17361 D or prior revisions only.

⑦ “G” indicates generator breakers. Refer to Eaton for further information.

### Note:

These breakers are non-repairable per NAVSEA letter, serial number 9077 Ser 03/03 EI-48, paragraph 3 Policy, sub-paragraph 2, dated 25 October 1994.

**AQB-A101 AND NQB-A101 CIRCUIT BREAKER PRODUCT SELECTION — BREAKERS WITH ATTACHMENTS ①②**

TYPE ③④⑤	TRIP UNIT RATING	INSTANTANEOUS TRIP SETTING ⑥ AC 60 CYCLE		STYLE NUMBER	ATTACHMENT ⑦	NATIONAL STOCK NUMBER
		HIGH	LOW			
<b>60 Hz</b>						
AQB-A101	15	180 – 210	75 – 105	<b>5682D24G13</b>	120 Vac Shunt Trip	5925-00-813-2470
AQB-A101	25	300 – 350	125 – 175	<b>5682D24G14</b>	120 Vac Shunt Trip	5925-01-028-6500
AQB-A101	50	600 – 700	250 – 350	<b>5682D24G15</b>	120 Vac Shunt Trip	5925-01-241-3396
AQB-A101	75	900 – 1050	375 – 525	<b>5682D24G16</b>	120 Vac Shunt Trip	5925-00-167-7513
AQB-A101	100	1200 – 1400	500 – 700	<b>5682D24G17</b>	120 Vac Shunt Trip	5925-00-938-3446
NQB-A101	100	Non-Automatic	—	<b>5682D24G19</b>	120 Vac Shunt Trip	5930-01-197-4752
<b>400 Hz</b>						
AQB-A101	15H	180 – 210	75 – 105	<b>5682D24G36</b>	120 Vac Shunt Trip	5925-01-359-1968
AQB-A101	25H	300 – 350	125 – 175	<b>5682D24G37</b>	120 Vac Shunt Trip	5925-01-339-4840
AQB-A101	50H	600 – 700	250 – 350	<b>5682D24G38</b>	120 Vac Shunt Trip	5925-01-339-4839
AQB-A101	75H	900 – 1050	375 – 525	<b>5682D24G39</b>	120 Vac Shunt Trip	5925-01-359-1969
AQB-A101	100H	1200 – 1400	500 – 700	<b>5682D24G40</b>	120 Vac Shunt Trip	5925-01-293-9163

① For list prices, see Price and Availability Digest (PAD).

② For other configurations, call Eaton.

③ Complete breaker does not include mounting bases. Type required must be ordered separately.

④ Front connected bases include cable lugs. Cover cable sizes 2828CM to 100,000CM.

⑤ Only 3-pole breakers are furnished, for 2-pole applications make connections to outside poles.

⑥ Instantaneous trip setting at 1200 – 1400% HI or 500 – 700% LO. Set at LO position at factory.

⑦ Shunt trip with IAIB Auxiliary Switch.

**Note:**

These breakers are non-repairable per NAVSEA letter, serial number 9077 Ser 03/03 EI-48, paragraph 3 Policy, sub-paragraph 2, dated 25 October 1994.

# Types AQB-A101, NQB-A101

## SWITCHBOARD/PANELBOARD MOUNTING

TYPE	STYLE NUMBER	NET WEIGHT, LBS. (KG)	NATIONAL STOCK NUMBER
Single Base — Front Connected	<b>315C364G03</b>	2.75 (1.2)	5925-00-832-6143
Single Base — Rear Connected	<b>315C364G02</b>	3.00 (1.4)	5925-00-521-2526
Single Base — Rear Connected, Line Front Connected, Load for Use with Rear Connected Fuse Base	<b>315C364G07</b>	3.00 (1.4)	—
Double Base Front Connected	<b>458D569G02</b>	3.50 (1.6)	5925-00-728-5217
Double Base Rear Connected	<b>458D569G03</b>	4.00 (1.8)	5925-01-221-8617

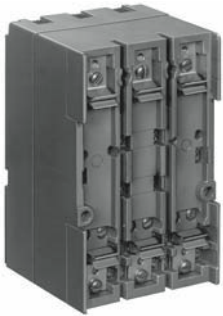

**AQB-A101 Breaker with Single Front Connected Base**



**AQB-A101 Breaker with Single Front Connected Base**



**AQB-A101 Single Mounting Base — Rear Connected**



**AQB-A101 Double Mounting Base — Front Connected**

## Fuse Unit Assemblies

AQB-F101A and AQB-F101B fuse units are designed for use in conjunction with standard AQB-A101 circuit breakers on circuits where a fault potential of up to 100,000 amperes exists.

For ordering information, see **Page 5**.

## NET WEIGHT

DESCRIPTION	NET WEIGHT, LBS. (KG)
AQB-A101 Breaker	6.00 (2.7)
NQB-A101 Breaker	5.75 (2.6)
AQB-F101A Fuse Unit	2.00 (0.9)
AQB-F101B Fuse Unit	2.00 (0.9)
Fuse Unit Mounting Base	3.00 (1.4)



## COMPLETE FUSE UNIT ASSEMBLY

## SHIPPED AS:

### FUSE UNIT ①

### FUSE UNIT MOUNTING BASE

STYLE NUMBER	AMPERE RATING	CONNECTION	TYPE	STYLE NUMBER	NATIONAL STOCK NUMBER	STYLE NUMBER	NATIONAL STOCK NUMBER
<b>372B155G01</b>	15 – 25	Front	AQB-F101A	<b>504C010H01</b>	5920-00-215-4727	<b>655D258G01</b> ②	5925-00-998-1965
<b>372B155G02</b>	15 – 25	Rear	AQB-F101A	<b>504C010H01</b>	5920-00-215-4727	<b>655D258G05</b> ②	5920-01-216-6127
<b>372B155G03</b>	50, 75 and 100	Front	AQB-F101B	<b>504C010H02</b>	5920-01-281-4158	<b>655D258G03</b>	5920-01-138-0548
<b>372B155G04</b>	50, 75 and 100	Rear	AQB-F101B	<b>504C010H02</b>	5920-01-281-4158	<b>655D258G06</b>	5920-01-216-6128

① Individual fuses are not replaceable; replace with complete unit.

② To convert for use with high rating unit (AQB-F101B) in field, remove rejection pin per instructions on fuse unit mounting base nameplate.

## Additions

### Shunt Trip

Breakers can be equipped with a shunt trip attachment for tripping the breaker from a remote point, and can be supplied with coils for 120 volts, 60 cycle or for 120 volts dc. These shunt trips have momentary rated coils and are supplied with an auxiliary switch to be wired in series for protection (Auxiliary switch included with the shunt trip. Do not order separately). Shunt trips are always mounted in the right pole. Leads extend 36 inches outside of breaker. For 400 Hz shunt trip contact Eaton.

To order, specify style number of standard breaker required plus shunt trip voltage and frequency. Must be factory installed. Net weight .3 lbs.

### Auxiliary Switch

Breakers can be supplied with internally mounted auxiliary switch to open or close control circuits as breaker operates. Each switch provides one "A" contact and one "B" contact. "A" contact is closed when breaker is closed, open when breaker is open. "B" contact is open when breaker is closed and closed when breaker is open. When ordered with one switch it is normally mounted in right pole, may be specified mounted in left pole. A maximum of 2 switches can be supplied: one in left and one in right pole. Order by description. Must be factory installed. Net weight .3 lbs.

#### Note:

One auxiliary switch normally supplied with shunt trip attachments for cut-off switch and additional switches cannot be supplied on breakers with shunt trips.

### Handle Lock

When specified, order style 1614485.

NSN 5930-00-669-7524.

### Handle Boot

When specified, order style number 752B729H01.

### Rear Stud

Complete with 4 nuts, style number 208B801G01.

### Fungus-Moisture Resistant Treatment

(JAN-T-152, JAN-C-173 or MIL-V-173). If specified, contact Eaton. External parts are coated.

### Technical Manual

Navships No. 362-2314. This booklet per MIL-M-15071. When required, order BVR-TM-475C.

## Drawings Available

900J429 — Master drawing for breaker and mounting bases.

900J439 — Master drawing for breaker with fuse unit and mounting bases.

459D448 — Outline and wiring diagram for breaker on single base.

654D255 — Outline and wiring diagram for breaker with fuse unit on single base.

459D449 — Outline and wiring diagram for breaker on double base.

654D256 — Outline and wiring diagram for breaker with fuse unit on double base.

657D205 — For fuse unit mounting base only.

### Individual Reproductions

When required, reproduction of master drawings, outline drawings and certification sheets can be ordered as follows:

ITEM	DESCRIPTION
1	Full size photolithographic tracing of master drawing on vellum
2	Outline and drilling plan on vellum
3	Certification data on vellum
4	Reproductions of Items 1, 2 or 3

# Types AQB-A101, NOB-A101, AQB-A103, NOB-A103

## Outline Dimensions AQB-A101 and AQB-A103 Breakers — Dimensions in Inches

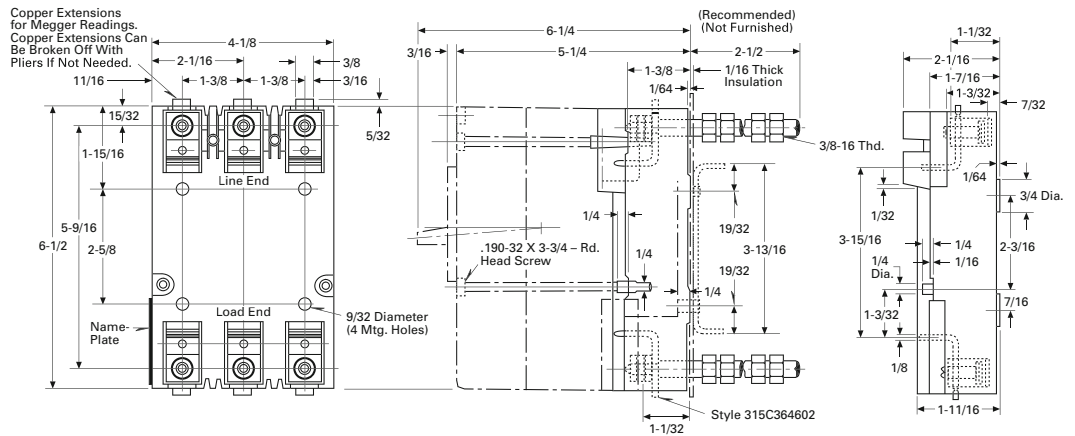

## For Single Breaker Mounted Base

## Single Breaker (Rear Mounted)

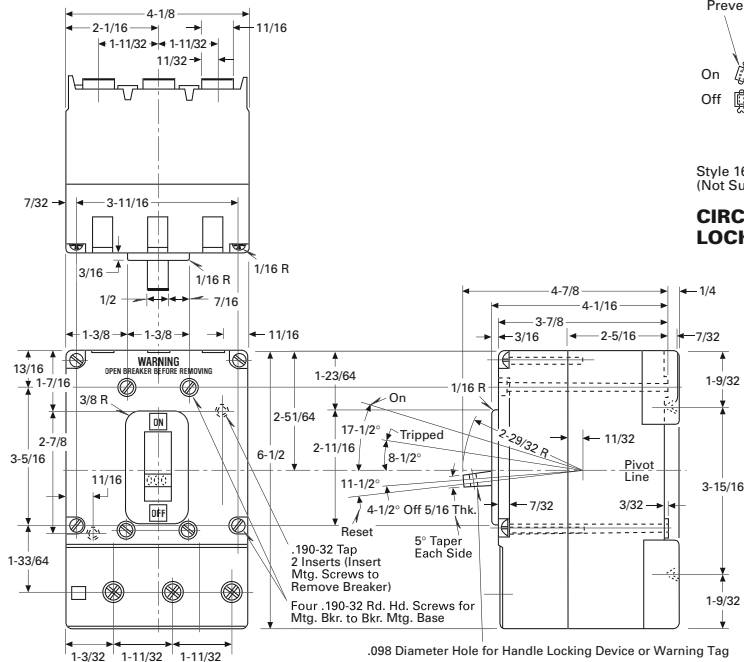

## Drilling Plan

For Single Mounted Base

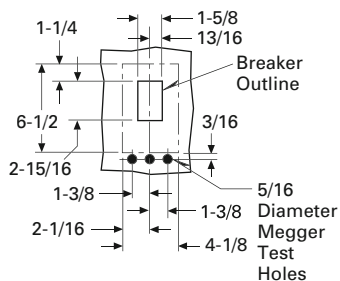

**Outline Dimensions  
AQB-A101 and AQB-A103  
Breaker Mounting Bases —  
Dimensions in Inches**

**For Two Breaker  
Mounting Base**

**For Double Mounting Base  
Front Connected**

**For Double Mounting Base  
Rear Connected**

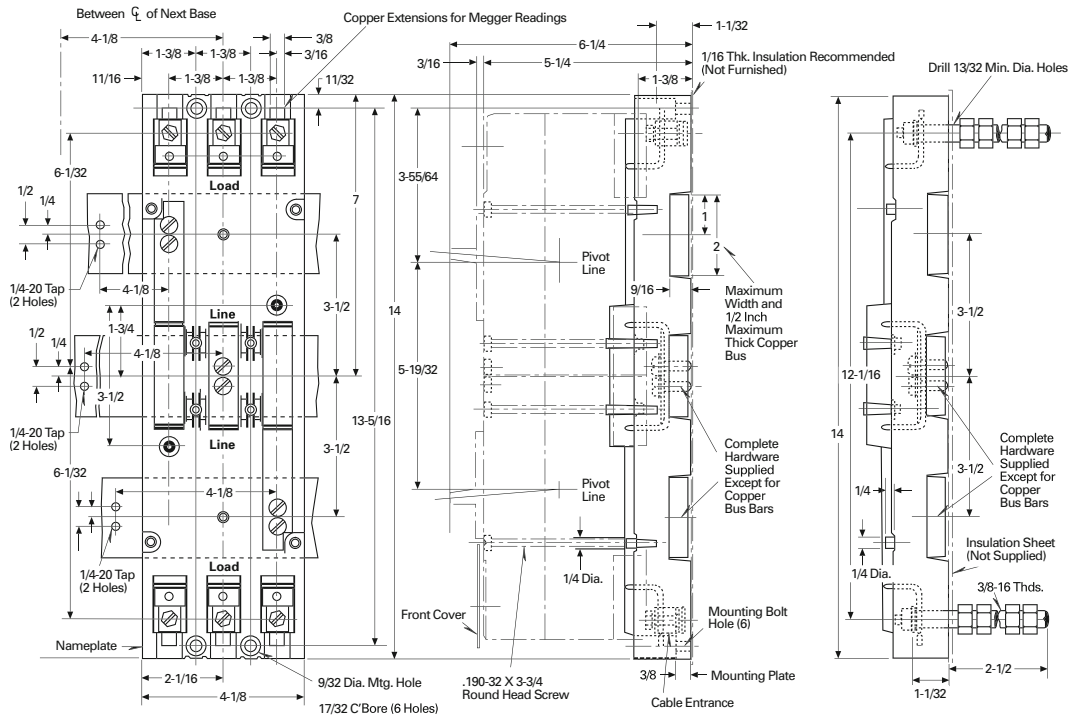

**Front Cover Cutouts for  
Double Mounting Base**

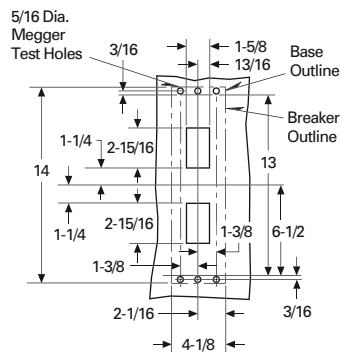



# Types AQB-A101, NOB-A101, AQB-A103, NOB-A103

## For Mounting of Breaker (Front Connected)

## For Mounting of Breaker (Rear Connected)

For Dimensions of Breaker and Mounting Base, See Drawing Number 459D448.

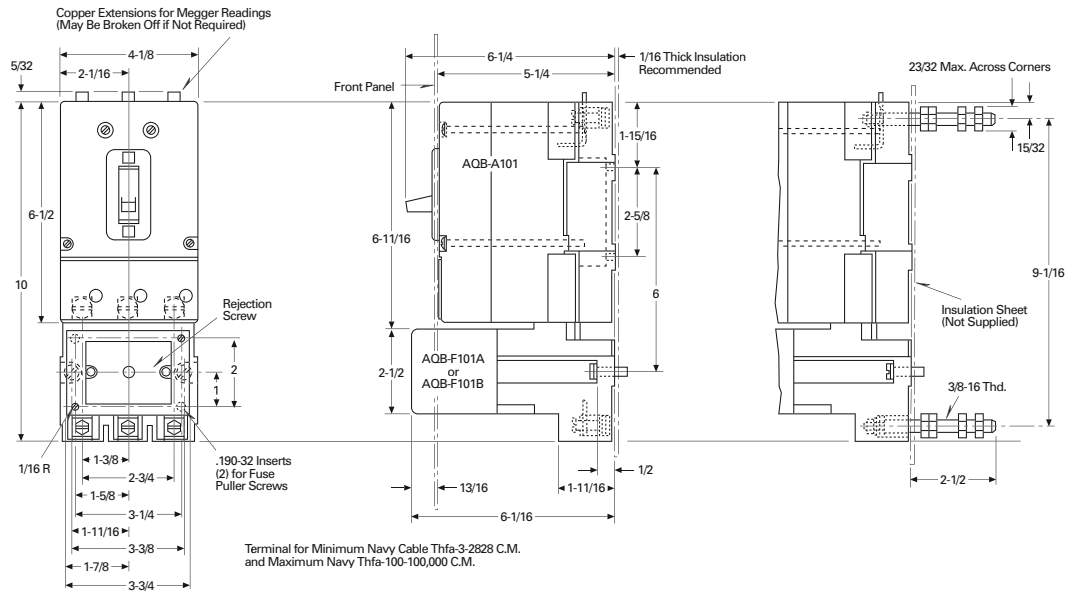

## Drilling Plan

For Rear Connected Studs  
and Mounting Bases.

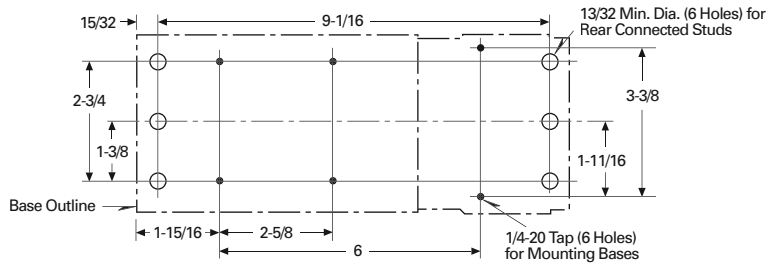

## Front Panel Cutout

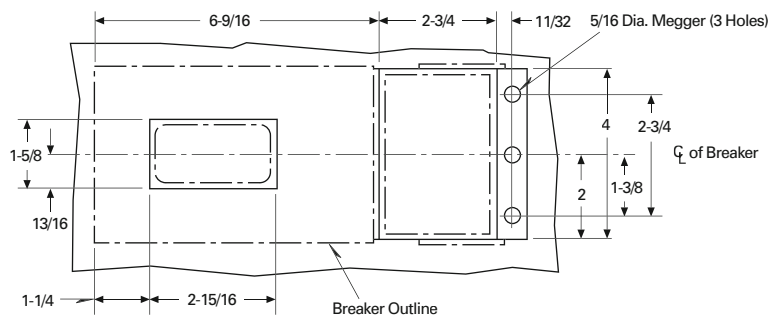

**Outline Dimensions  
AQB-A101 and AQB-A103  
Breakers, Double Base with  
Fuse Units — Dimensions in  
Inches**

**For Mounting of Two  
Breakers (Front Connected)**

**For Mounting of Two  
Breakers (Rear Connected)**

For Dimensions of Breaker and  
Mounting Base, See Drawing  
Number 459D449.

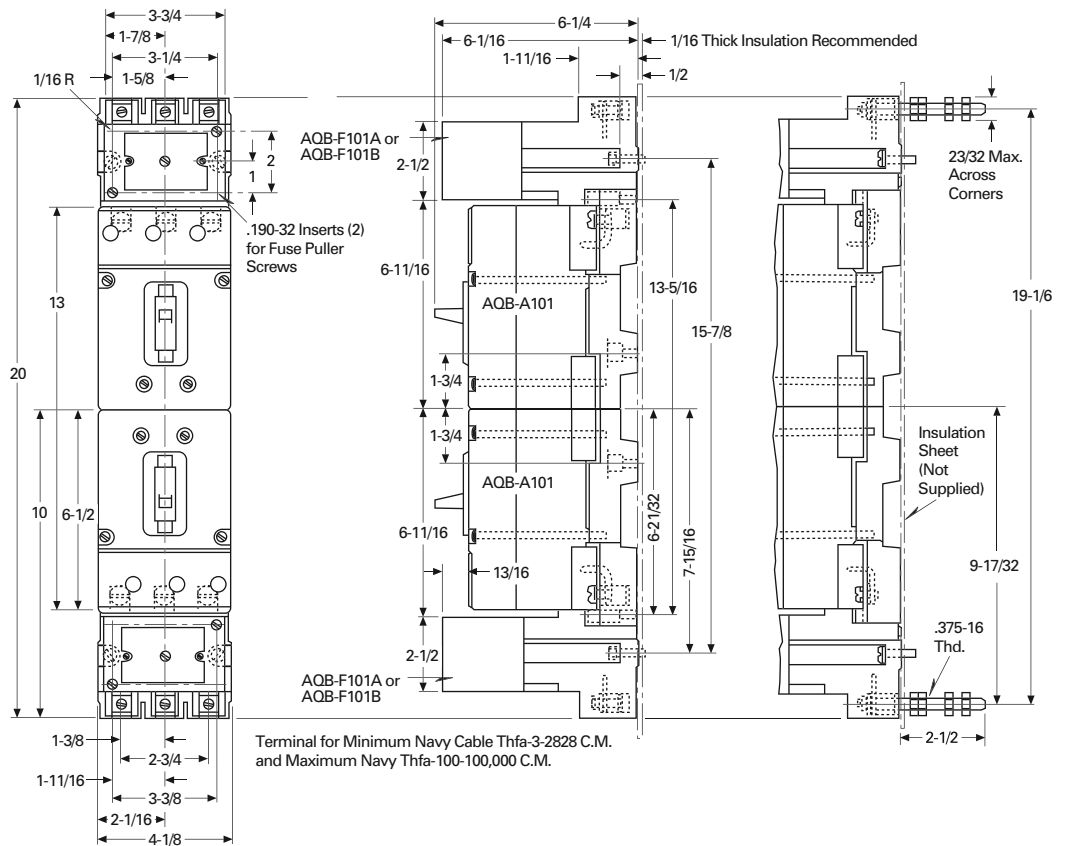

**Drilling Plan**

For Rear Connected Studs  
and Mounting Bases.

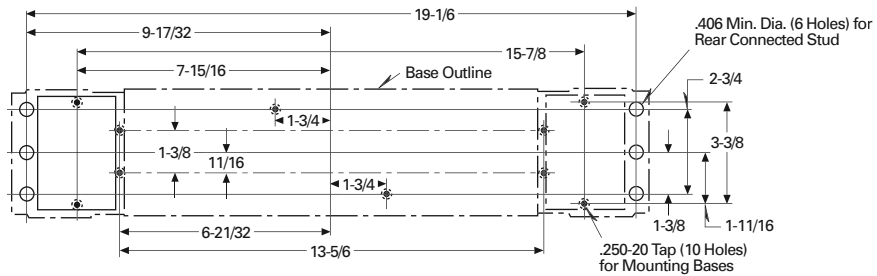

**Front Panel Cutout**

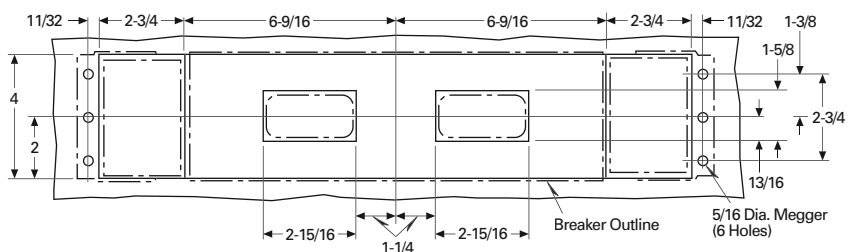

# Types AQB-A101, NQB-A101, AQB-A103, NQB-A103

## Characteristic Time-Current Curves

### AQB-A101 Breakers

#### Operating Characteristics

Trip Unit Rating 15 – 100  
Amperes 50°C Ambient —  
Cold Start, 60 Cycle, ac or dc,  
Thermal-Magnetic.

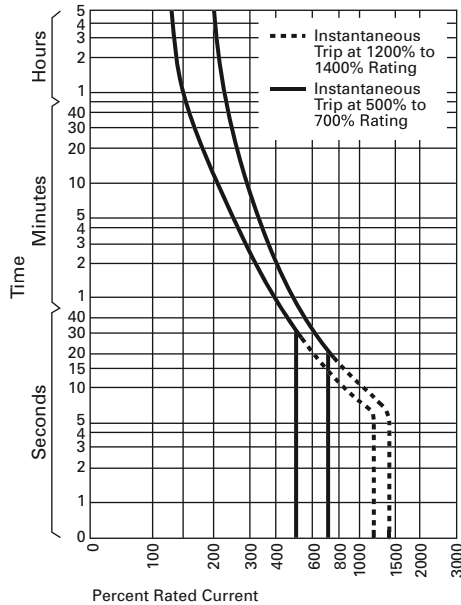

### 400 Cycle Breakers

#### Operating Characteristics

Trip Unit Rating 15 – 100  
Amperes 50°C Ambient —  
Cold Start 400 Cycle ac, Thermal-  
Magnetic Trip Unit Rating.

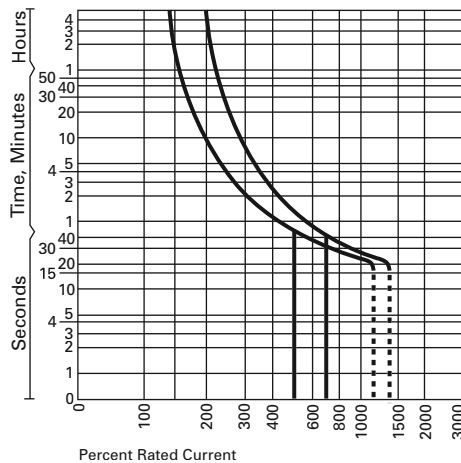

## Trip Unit Rating

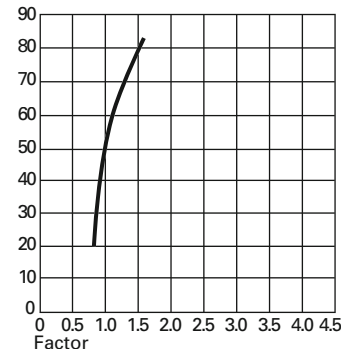

To determine the trip unit rating to be used, when the load current and ambient are known, multiply the load current by the factor obtained from this curve for the known ambient. The result will be the ideal trip unit rating. However, since trip units are furnished only with standard ratings as per Navy spec., select the standard trip unit whose rating is equal to or one rating higher than the ideal rating.

### Specification MIL-C-17361

This specification covers all thermal-magnetic AQB breakers. It requires that they carry 150% of current ratings for at least one hour and that thermal elements initiate tripping at 225% rated current within one hour and at 600% in 25 seconds plus or minus 25%. The instantaneous magnetic settings for each continuous ratings are based on intended applications. (Thermal tripping tests are conducted with all poles in series in 50°C ambient; each pole is tested individually to check magnetic settings.)

## Characteristic Time-Current Curves

### Generator Breakers

50°C Ambient — Cold Start "G" rating, 60 or 400 Cycle ac or dc, Thermal-Magnetic.

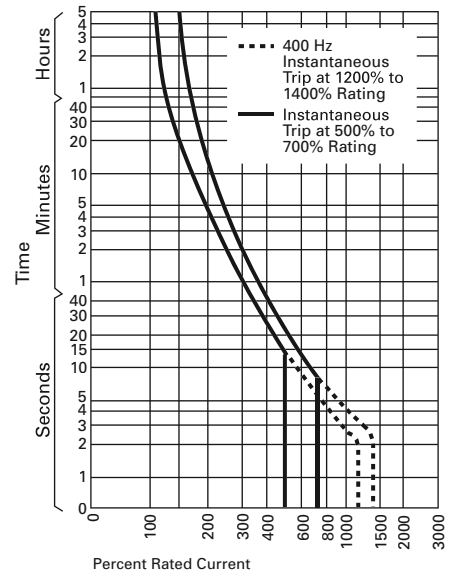
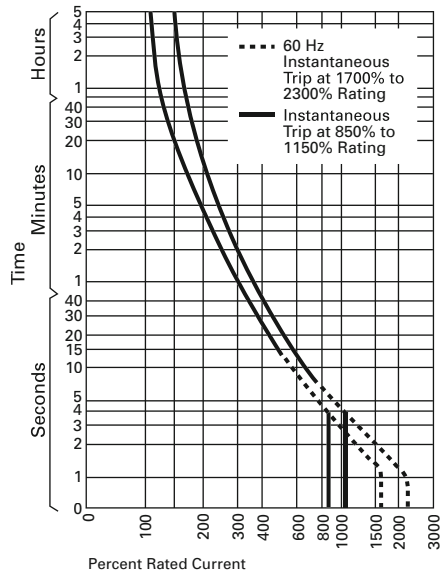

# Types AQB-A103RMS, NQB-A103

## Circuit Breakers for Naval Shipboard Use — Types AQB-A103 RMS, NQB-A103 Breakers

500 Volts ac, 100 Amperes  
Maximum, 15,000 Amperes I.C.



### Specifications: MIL-C-17361

- 10 – 100 amperes.
- 500 volts ac (No dc).
- 60/400 Hz (Universal).
- 3-pole.

### Interrupting Rating

- 15,000 amperes, 60 Hz ac.
- 7,500 amperes, 400 Hz ac.
- 100 kA with fuse kit units.
- Class: Hi shock MIL-S-901: 50°C ambient.

AQB-A103 RMS circuit breakers are designated for use in lighting and distribution panelboards and for switchboards in the protection of feeder and motor branch circuits.

The AQB-A103 RMS now features true rms sensing, which works on any waveform shape, is more accurate and is less sensitive to nuisance tripping. AQB-A103 RMS circuit breakers are form fit and function interchangeable with A101 circuit breakers. The electronic trip unit provides better shock immunity, enhanced trip curve shaping capabilities, improved selectivity and system coordination, and dramatic logistical savings.

NQB-A103 circuit breakers have a maximum continuous current rating of 100 amperes. They are used only as disconnects, since they do not include an automatic opening device.

### AQB-A103RMS Characteristics

Continuous Current Setting (6-Position Selector Switch)

10 – 25 Amperes (10, 12.5, 15, 18.75, 20, 25)

40 – 100 Amperes (40, 50, 60, 75, 80, 100)

Instantaneous Pickup — Adjustable in multiples of 25 or 100 ampere frame rating (6x, 8x, 10x, 12x, 15x, 20x, 30x, 40x)

Short Delay Pickup — Adjustable in multiples of continuous current setting (2x, 3x, 5x, 7x, 9x, 10x, 13x, 14x)

Short Delay Time — Adjustable with bands Min., 1, 2, 3, Max., plus 3 new flat response curves at 100 ms, 200 ms and 300 ms. (See trip curve.)

### Net Weight

AQB — 6.0 lbs. (2.7 kg.)

NQB — 5.75 lbs. (2.6 kg.)

### Drawings Available

1376D98 Master

1376D60 Outline

### Technical Manual

1244C68H01

### STK-2 Portable Test Kit

For switchboards and panelboard mounting and other accessories see **Pages 36** and **37**.

For outline dimensions see **Pages 38 – 41**.

### AQB-A103 RMS AND NQB-A103 CIRCUIT BREAKER PRODUCT SELECTION <sup>①</sup>

AMPERES	STYLE NUMBER <sup>②③④⑤</sup>	NATIONAL STOCK NUMBER
10 – 25	<b>1376D96G01</b>	5925-01-455-8639
40 – 100	<b>1376D96G02</b>	5925-01-455-8635
10 – 25	<b>1376D96G07</b> with 115 Vac ST	5925-01-482-1112
40 – 100	<b>1376D96G08</b> with 115 Vac ST	5925-01-482-1134
100	<b>1376D96G51</b> NQB-A103	5925-01-456-0004

<sup>①</sup> For list prices, See Price and Availability Digest (PAD).

<sup>②</sup> Complete breaker does not include mounting bases. Type required must be ordered separately.

<sup>③</sup> Front connected bases include cable lugs. Cover cable sizes 2828CM to 100,000CM.

<sup>④</sup> Only 3-pole breakers are furnished, for 2-pole applications make connections to outside poles.

<sup>⑤</sup> ST is shunt trip which has its own built-in cutoff switch and always left pole.

# Types AQB-A103, NQB-A103

## Characteristic Time-Current Curve Navy Type AQB-A103 RMS Circuit Breaker

### Time-Current Curve for AQB-A103 RMS Circuit Breaker (Long Delay and Short Delay with Flat Response)

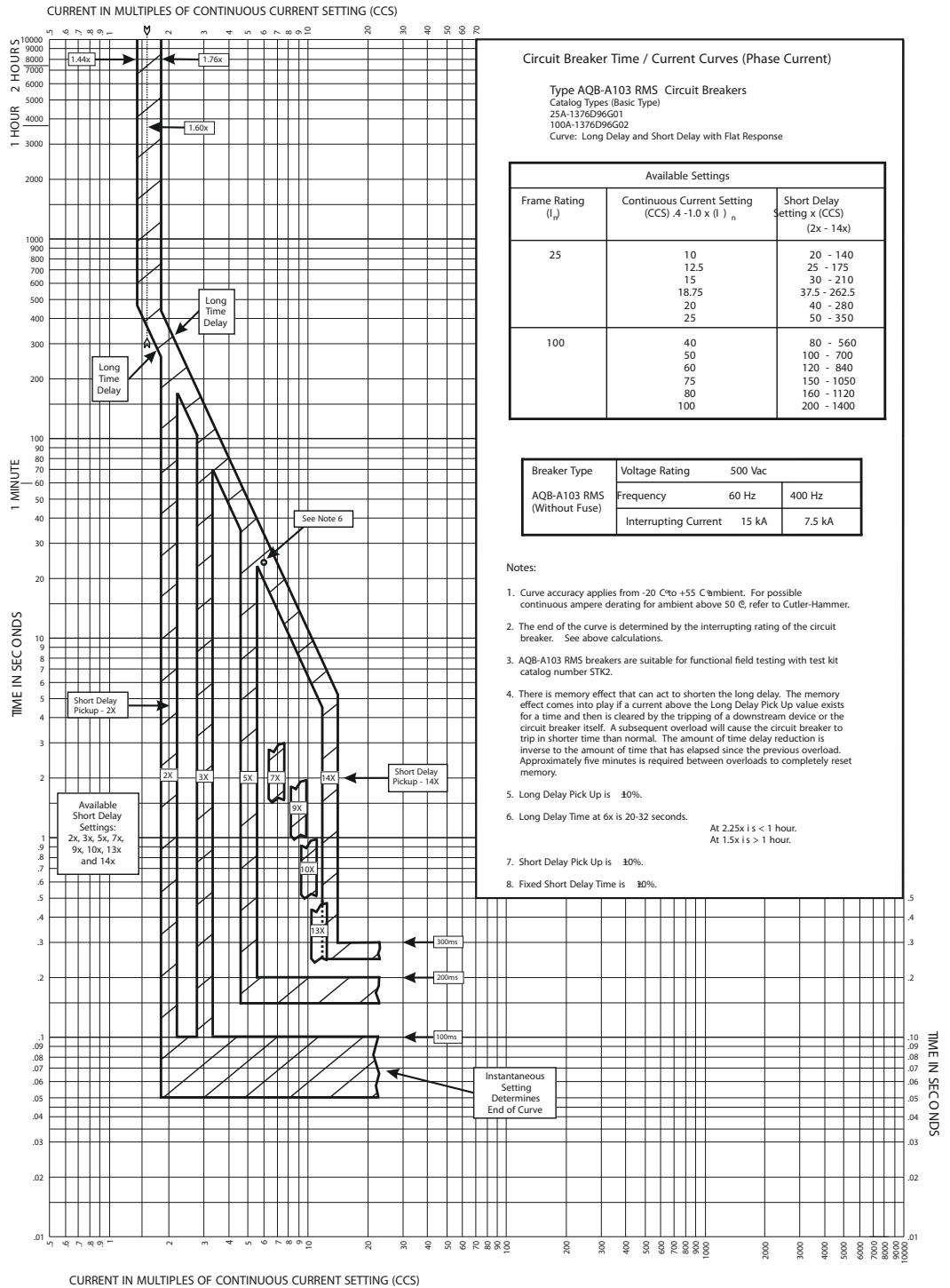

**CURVE NO. SC-7238-02**

# Types AQB-A103, NQB-A103

## Characteristic Time-Current Curve Navy Type AQB-A103 RMS Circuit Breaker

### Time-Current Curve for AQB-A103 RMS Circuit Breaker (Long Delay and Short Delay with I<sup>2</sup>t Response)

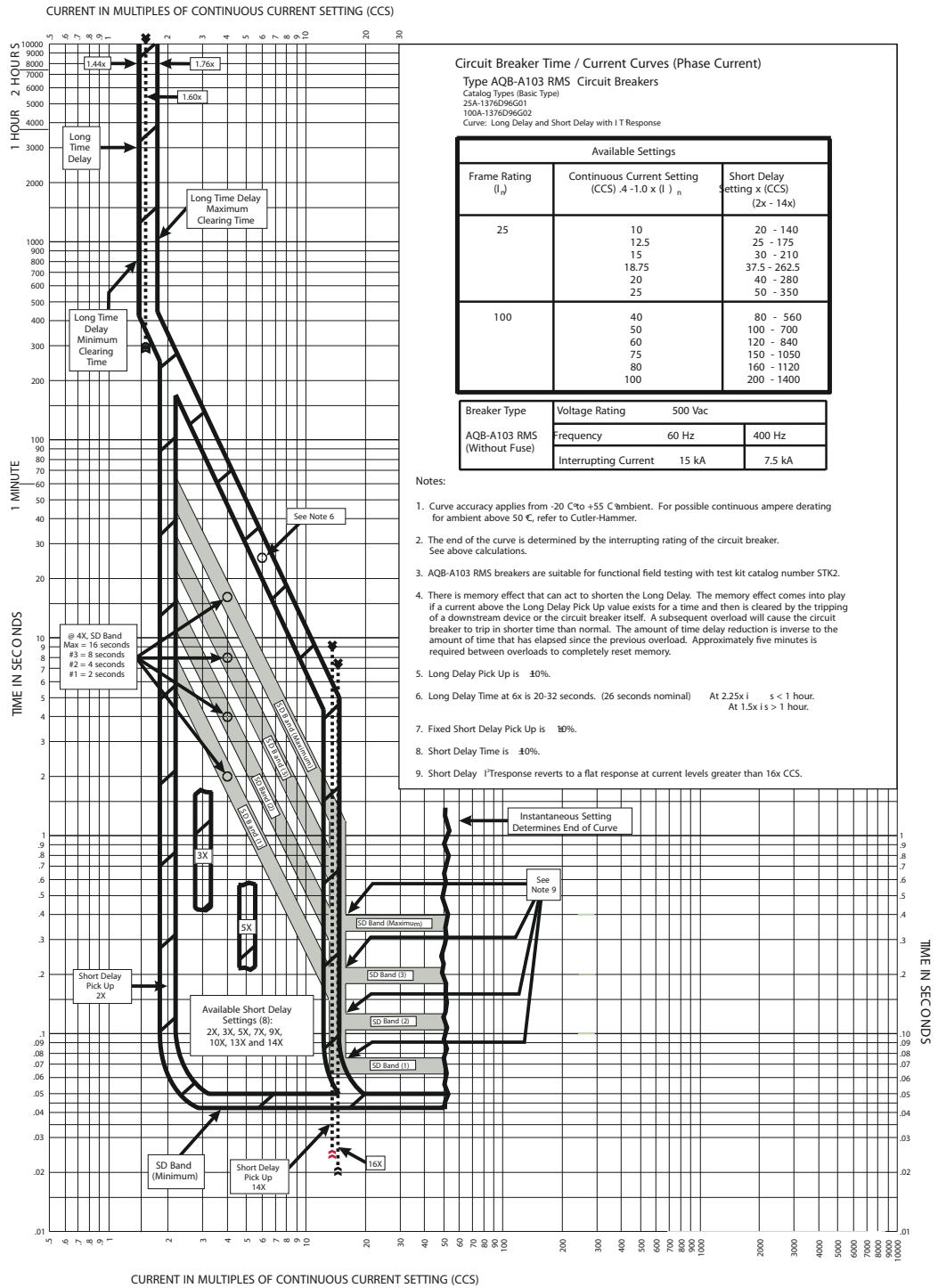

**Characteristic Time-Current Curve Navy Type AQB-A103 RMS Circuit Breaker**

**Time-Current Curve for AQB-A103 RMS Circuit Breaker (Instantaneous Response)**

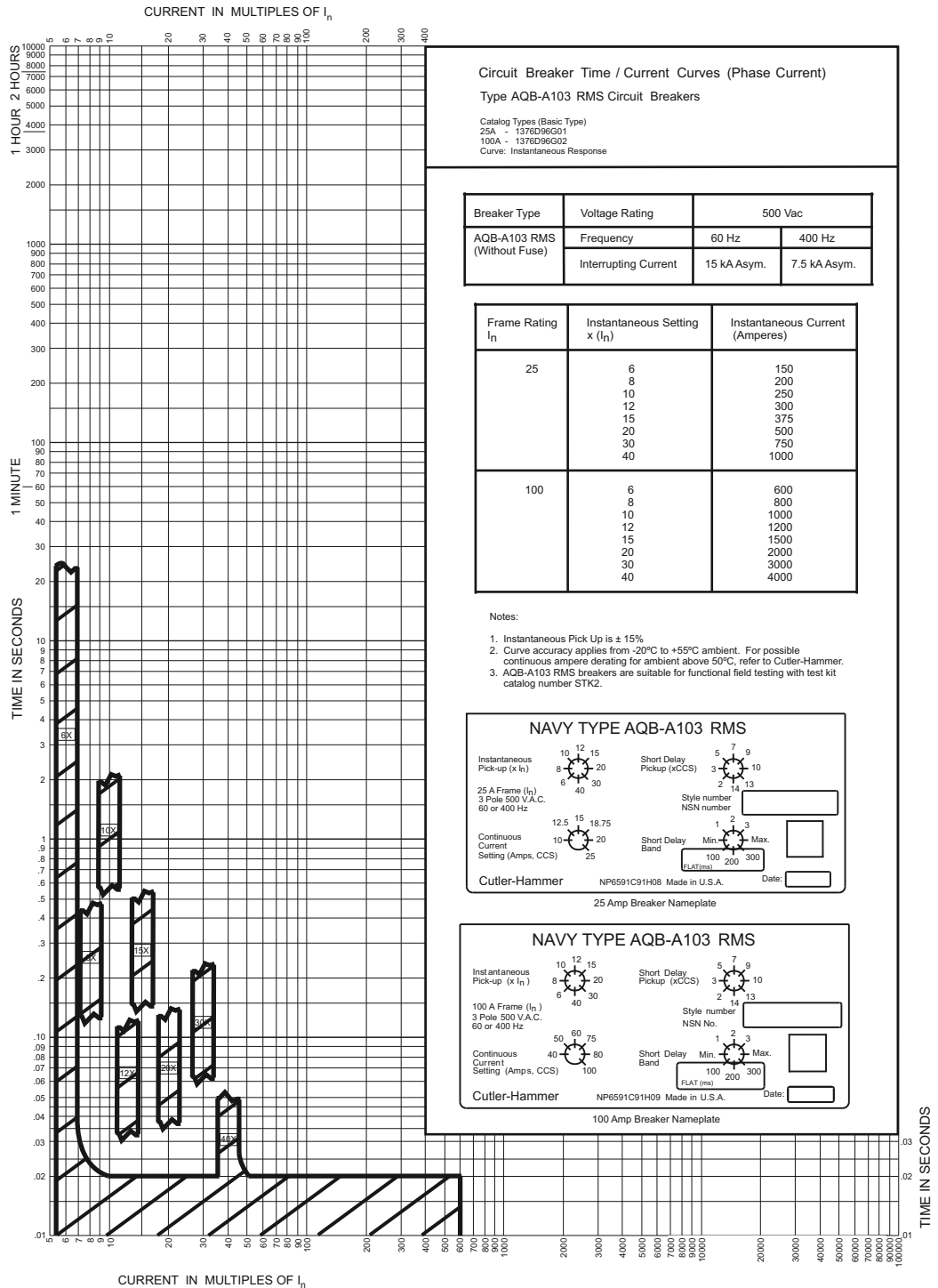

Circuit Breaker Time / Current Curves (Phase Current)  
 Type AQB-A103 RMS Circuit Breakers  
 Catalog Types (Basic Type)  
 25A - 1376D96G01  
 100A - 1376D96G02  
 Curve: Instantaneous Response

Breaker Type	Voltage Rating	500 Vac	
AQB-A103 RMS (Without Fuse)	Frequency	60 Hz	400 Hz
	Interrupting Current	15 kA Asym.	7.5 kA Asym.

Frame Rating In	Instantaneous Setting x (In)	Instantaneous Current (Amperes)
25	6	150
	8	200
	10	250
	12	300
	15	375
	20	500
	30	750
100	6	600
	8	800
	10	1000
	12	1200
	15	1500
	20	2000
	30	3000
40	4000	

- Notes:
1. Instantaneous Pick Up is ± 15%
  2. Curve accuracy applies from -20°C to +55°C ambient. For possible continuous ampere derating for ambient above 50°C, refer to Cutler-Hammer.
  3. AQB-A103 RMS breakers are suitable for functional field testing with test kit catalog number STK2.

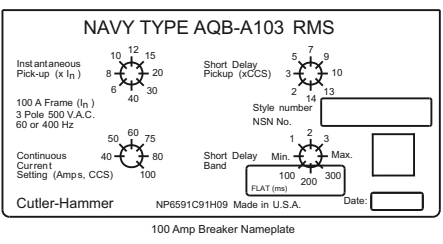
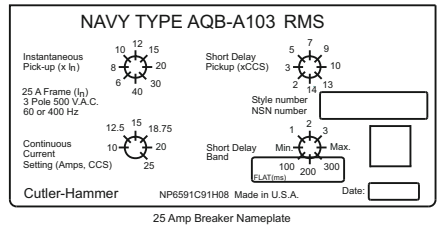

**CURVE NO. SC-7238-02**



# Types AQB-A250, NQB-A250

## Circuit Breakers for Naval Shipboard Use — Types AQB-A250, NQB-A250 Breakers

250 Volts dc, 500 Volts ac,  
250 Amperes Maximum, 20,000  
Amperes ac, 15,000 Amperes  
dc I.C.



### Specification: MIL-C-17361

- 100 – 250 amperes.
- 500 volts ac and 250 volts dc.
- 2- and 3-pole.

### Interrupting Ratings

- 20,000 amperes ac and  
15,000 amperes dc.

AQB-A250 circuit breakers are used primarily to protect feeder circuits, however, those followed by “NM” in the table have higher magnetic settings to allow for motor starting. Breakers with settings specifically for use with generators are designated “NG” in the table.

These breakers are available with interchangeable trip units in ratings of 125, 150, 175, 225 and 250 amperes. The nonautomatic NQB-A250 carries a 250 ampere rating and has copper conductors replacing the trip unit. Special generator breakers have trip units rated at 100, 160 and 250 amperes.

AQB-A250 breakers can be ordered with undervoltage release devices, auxiliary switches and shunt trip attachments complete with auxiliary switch. These attachments are also easily installed in the field.

### AQB-A250 AND NQB-A250 CIRCUIT BREAKER PRODUCT SELECTION ①

CONTINUOUS AMPERE RATING	INSTANTANEOUS TRIP SETTING — AMPERES				COMPLETE BREAKER ②		BREAKER FRAME ONLY ②		TRIP UNIT ONLY	
	AC LOW	AC HIGH	DC LOW	DC HIGH	STYLE NUMBER	NATIONAL STOCK NUMBER	STYLE NUMBER	NATIONAL STOCK NUMBER	STYLE NUMBER	NATIONAL STOCK NUMBER
<b>2-Pole 500 Volts ac, 250 Volts dc</b>										
125-N	650	1300	650	1300	<b>313C682G03</b>	5925-01-233-6525	<b>452D370G01</b>	5925-00-796-4371	<b>452D371G03</b>	—
125-NM	1950	3900	2250	4100	<b>313C682G04</b>	—	<b>452D370G01</b>	5925-00-796-4371	<b>452D371G04</b>	—
150-N	650	1300	650	1300	<b>313C682G05</b>	—	<b>452D370G01</b>	5925-00-796-4371	<b>452D371G05</b>	5925-00-793-6865
150-NM	1950	3900	2250	4100	<b>313C682G06</b>	—	<b>452D370G01</b>	5925-00-796-4371	<b>452D371G06</b>	—
175-N	650	1300	650	1300	<b>313C682G07</b>	—	<b>452D370G01</b>	5925-00-796-4371	<b>452D371G07</b>	5925-00-175-5058
175-NM	1950	3900	2250	4100	<b>313C682G08</b>	—	<b>452D370G01</b>	5925-00-796-4371	<b>452D371G08</b>	—
225-N	650	1300	650	1300	<b>313C682G09</b>	—	<b>452D370G01</b>	5925-00-796-4371	<b>452D371G09</b>	5925-00-064-7834
225-NM	1500	3000	1770	3550	<b>313C682G10</b>	—	<b>452D370G01</b>	5925-00-796-4371	<b>452D371G10</b>	—
250-N	650	1300	650	1300	<b>313C682G11</b>	—	<b>452D370G01</b>	5925-00-796-4371	<b>452D371G11</b>	—
250-NM	1700	3400	1850	3800	<b>313C682G12</b>	—	<b>452D370G01</b>	5925-00-796-4371	<b>452D371G12</b>	—
250 ③	Non-Auto	Non-Auto	Non-Auto	Non-Auto	<b>313C682G31</b>	—	<b>452D370G03</b>	—	<b>29B2710G05 ④</b>	—
<b>2-Pole 500 Volts ac, 250 Volts dc Generator Circuit Breaker Applications</b>										
100-NG	1175	2350	—	—	<b>313C682G13</b>	—	<b>452D370G01</b>	5925-00-796-4371	<b>452D371G13</b>	—
160-NG	1950	3900	—	—	<b>313C682G14</b>	—	<b>452D370G01</b>	5925-00-796-4371	<b>452D371G14</b>	—
250-NG	—	—	650	1300	<b>313C682G15</b>	—	<b>452D370G01</b>	5925-00-796-4371	<b>452D371G15</b>	—

① For list prices, see Price and Availability Digest (PAD).

② Styles listed include slip-type connectors for rear connections. Order front terminal connectors separately if required; see Page 50. No additional charges for front connectors ordered with breakers or frames.

③ Type NQB-A250 non-automatic.

④ Not to be used with attachments; if required, order dummy trip unit 452D371G31 for 3-pole and 452D371G16 for 2-pole.

### Note:

Breakers with ratings other than those given on this page are considered as special and full description data must be provided.

**AQB-A250 AND NQB-A250 CIRCUIT BREAKER PRODUCT SELECTION (CONTINUED) ①**

CONTINUOUS AMPERE RATING	INSTANTANEOUS TRIP SETTING — AMPERES				COMPLETE BREAKER ②		BREAKER FRAME ONLY ②		TRIP UNIT ONLY	
	AC		DC		STYLE NUMBER	NATIONAL STOCK NUMBER	STYLE NUMBER	NATIONAL STOCK NUMBER	STYLE NUMBER	NATIONAL STOCK NUMBER
	LOW	HIGH	LOW	HIGH						
<b>3-Pole 500 Volts ac, 250 Volts dc</b>										
125-N	650	1300	650	1300	<b>313C682G18</b>	5925-01-173-1114	<b>452D370G02</b>	5925-00-789-3718	<b>452D371G18</b>	5925-00-795-4958
125-NM	1950	3900	2250	4100	<b>313C682G19</b>	5925-01-031-9909	<b>452D370G02</b>	5925-00-789-3718	<b>452D371G19</b>	5925-00-839-0289
150-N	650	1300	650	1300	<b>313C682G20</b>	5925-01-229-4448	<b>452D370G02</b>	5925-00-789-3718	<b>452D371G20</b>	5925-00-795-4957
150-NM	1950	3900	2250	4100	<b>313C682G21</b>	5925-01-303-8381	<b>452D370G02</b>	5925-00-789-3718	<b>452D371G21</b>	5925-00-839-0290
175-N	650	1300	650	1300	<b>313C682G22</b>	5925-00-499-0088	<b>452D370G02</b>	5925-00-789-3718	<b>452D371G22</b>	5925-00-796-4439
175-NM	1950	3900	2250	4100	<b>313C682G23</b>	5925-01-305-6194	<b>452D370G02</b>	5925-00-789-3718	<b>452D371G23</b>	—
225-N	650	1300	650	1300	<b>313C682G24</b>	5925-01-306-0120	<b>452D370G02</b>	5925-00-789-3718	<b>452D371G24</b>	5925-00-839-0291
225-NM	1500	3000	1770	3550	<b>313C682G25</b>	5925-01-210-5267	<b>452D370G02</b>	5925-00-789-3718	<b>452D371G25</b>	5925-00-839-0292
250-N	650	1300	650	1300	<b>313C682G26</b>	5925-01-452-0162	<b>452D370G02</b>	5925-00-789-3718	<b>452D371G26</b>	5925-00-839-0293
250-NM	1700	3400	1850	3800	<b>313C682G27</b>	5925-01-272-3805	<b>452D370G02</b>	5925-00-789-3718	<b>452D371G27</b>	5925-00-690-7568
250 ③	Non-Auto		Non-Auto		<b>313C682G36</b>	5930-00-900-0247	<b>452D370G04</b>	5925-00-831-8801	<b>29B2710G06 ④</b>	5925-00-831-8800
<b>3-Pole 500 Volts ac, 250 Volts dc Generator Circuit Breaker Applications</b>										
100-NG	1175	2350	—	—	<b>313C682G28</b>	5925-01-080-2226	<b>452D370G02</b>	5925-00-789-3718	<b>452D371G28</b>	5925-00-852-7809
160-NG	1950	3900	—	—	<b>313C682G29</b>	5925-01-104-4625	<b>452D370G02</b>	5925-00-789-3718	<b>452D371G29</b>	5925-00-795-4956
250-NG	—	—	650	1300	<b>313C682G30</b>	—	<b>452D370G02</b>	5925-00-789-3718	<b>452D371G30</b>	—

① For list prices, see Price and Availability Digest (PAD).

② Styles listed include slip-type connectors for rear connections. Order front terminal connectors separately if required; see Page 50. No additional charges for front connectors ordered with breakers or frames.

③ Type NQB-A250 non-automatic.

④ Not to be used with attachments; if required, order dummy trip unit 452D371G31 for 3-pole and 452D371G16 for 2-pole.

**Note:**

Breakers with ratings other than those given on this page are considered as special and full description data must be provided.

# Types AQB-A250, NQB-A250

## AQB-A250, NQB-A250 CIRCUIT BREAKER PRODUCT SELECTION (CONTINUED) ①

CONTINUOUS AMPERE RATING	INSTANTANEOUS TRIP SETTING IN AMPERES ②				COMPLETE BREAKER ③		BREAKER FRAME ONLY ③		TRIP UNIT ONLY	
	AC		DC		STYLE NUMBER	NATIONAL STOCK NUMBER	STYLE NUMBER	NATIONAL STOCK NUMBER	STYLE NUMBER	NATIONAL STOCK NUMBER
	LOW	HIGH	LOW	HIGH						
<b>400 Cycle, 2-Pole, 500 Volts ac</b>										
125-NH	910	1560	—	—	315C574G03	—	452D370G01	5925-00-796-4371	457D446G03	—
150-NH	910	1560	—	—	315C574G05	—	452D370G01	5925-00-796-4371	457D446G05	—
175-NH	910	1560	—	—	315C574G07	—	452D370G01	5925-00-796-4371	457D446G07	—
225-NH	910	1560	—	—	315C574G09	—	452D370G01	5925-00-796-4371	457D446G09	—
250-NH	910	1560	—	—	315C574G11	—	452D370G01	5925-00-796-4371	457D446G11	—
<b>400 Cycle, 2-Pole, 500 Volts ac Generator Circuit Breaker Applications</b>										
100-NGH	2020	3420	—	—	315C574G13	—	452D370G01	5925-00-796-4371	457D446G13	—
160-NGH	2020	3420	—	—	315C574G14	—	452D370G01	5925-00-796-4371	457D446G14	5925-00-758-6227
250-NGH	2520	4200	—	—	315C574G15	—	452D370G01	5925-00-796-4371	457D446G15	—
<b>400 Cycle, 3-Pole, 500 Volts ac</b>										
125-NH	910	1560	—	—	315C574G18	—	452D370G02	5925-00-789-3718	457D446G18	5925-00-803-5491
150-NH	910	1560	—	—	315C574G20	5925-01-075-8931	452D370G02	5925-00-789-3718	457D446G20	5925-00-803-5488
175-NH	910	1560	—	—	315C574G22	5925-01-100-4027	452D370G02	5925-00-789-3718	457D446G22	5925-00-899-9904
225-NH	910	1560	—	—	315C574G24	5925-01-193-6055	452D370G02	5925-00-789-3718	457D446G24	5925-01-193-6056
250-NH	910	1560	—	—	315C574G26	5925-01-050-9032	452D370G02	5925-00-789-3718	457D446G26	5925-01-149-4269
<b>400 Cycle, Three-Pole, 500 Volts ac Generator Circuit Breaker Applications</b>										
100-NGH	2020	3420	—	—	315C574G28	—	452D370G02	5925-00-789-3718	457D446G28	5925-00-238-5198
160-NGH	2020	3420	—	—	315C574G29	5925-01-330-7615	452D370G02	5925-00-789-3718	457D446G29	5925-00-803-5489
250-NGH	2520	4200	—	—	315C574G30	5925-01-238-5706	452D370G02	5925-00-789-3718	457D446G30	5925-00-906-7803
<b>3-Pole, 500 Volts ac, 250 Volts dc Front Connect With Lugs</b>										
125-N	650	1300	650	1300	504C191G18	—	452D370G06	5925-01-178-8962	452D371G18	5925-00-795-4958
125-NM	1950	3900	2250	4100	504C191G19	5925-01-415-4641	452D370G06	5925-01-178-8962	452D371G19	5925-00-839-0289
150-N	650	1300	650	1300	504C191G20	—	452D370G06	5925-01-178-8962	452D371G20	5925-00-795-4957
150-NM	1950	3900	2250	4100	504C191G21	5925-01-437-4675	452D370G06	5925-01-178-8962	452D371G21	5925-00-839-0290
175-N	650	1300	650	1300	504C191G22	—	452D370G06	5925-01-178-8962	452D371G22	5925-00-796-4439
175-NM	1950	3900	2250	4100	504C191G23	—	452D370G06	5925-01-178-8962	452D371G23	5925-01-305-8589
225-N	650	1300	650	1300	504C191G24	5925-01-415-4638	452D370G06	5925-01-178-8962	452D371G24	5925-00-839-0291
225-NM	1500	3000	1770	3550	504C191G25	—	452D370G06	5925-01-178-8962	452D371G25	5925-00-839-0292
250-N	650	1300	650	1300	504C191G26	5925-01-415-4639	452D370G06	5925-01-178-8962	452D371G26	5925-00-839-0293
250-NM	1700	3400	1850	3800	504C191G27	—	452D370G06	5925-01-178-8962	452D371G27	5925-00-690-7568
250	Non-Auto	Non-Auto	—	—	504C191G36	5925-01-345-3653	452D370G08	5925-01-413-1629	29B2710G06 ④	5925-00-831-8800

① For list prices, see Price and Availability Digest (PAD).

② For 400 cycle breakers with higher instantaneous trip ratings, refer to Eaton.

③ Styles listed include slip-type connectors for rear connections. Order front terminal connectors separately if required. No additional charges for front connectors ordered with breakers or frames.

④ Not to be used with attachments; see prior Page 48.

### Note:

Breakers with ratings other than those given on this page are considered as special and full description data must be provided.

### Switchboard Mounting

Complete breakers and frames include mounting hardware. Female slip connectors are mounted in breaker base to plug onto stud projections of terminal mounting block assemblies. Order one mounting block assembly for each end of breaker.

DESCRIPTION	STYLE NUMBER	NET WEIGHT, LBS. (KG)	NATIONAL STOCK NUMBER
One Stud Assembly Complete with 4 Nuts	1631 443	1 (0.5)	—
Terminal Mounting Block (No Studs)	313C681G01	1 (0.5)	2920-01-354-4811
Mounting Block and Stud Set (3 Studs)	313C680G02	1.50 (0.7)	5940-01-146-6806

### Front Connected Breakers

For connections made at front terminals, pressure-type lugs required. If specified on same order, connectors furnished no charge. One connector per terminal. Select from the table to the right.

CABLE RANGE	AMPERES	DESCRIPTION	STYLE NUMBER	NATIONAL STOCK NUMBER
N40-N74	125	—	20B3055H14	5925-01-414-2467
N100-N125	150 – 175	Solderless	20B3055H15	5940-01-429-4972
N150-N200	250	Connector	20B3055H16	5999-01-413-1588

### NET WEIGHT

DESCRIPTION	NET WEIGHT, LBS. (KG)
AQB Complete, 3-Pole A250	20.50 (9.3)
NQB Complete, 3-Pole N250	17.50 (7.9)
3-Pole AQB, NQB Frame	17.00 (7.7)
AQB Trip Unit, 3-Pole	3.50 (1.6)
Motor Operator	18.00 (8.2)

### KIT TO CONVERT AQB FRAME TO NQB BREAKER

POLES	STYLE NUMBER ①	NATIONAL STOCK NUMBER	NET WEIGHT, LBS. (KG)
3	29B2710G06	5925-00-831-8800	.50 (0.2)
2	29B2710G05	—	.50 (0.2)

① Not to be used with attachments; see Page 48.

### Note:

Breaker with ratings other than those given on this page are considered as special and full description data must be provided.

# Types AQB-A250, NQB-A250

## Additions

### Handle Lock

If required, order style 28B4596G01. One furnished no charge per 10 breakers ordered, when requested. Net weight 0.15 lbs. (0.07 kg).

### Mechanical Interlock

If mechanical interlock (switch-board use) is desired for a pair of breakers, order by description. (Not submitted for Navy approval.)

### Auxiliary Switch

The most commonly used, standard mounting is left pole with leads exiting rear when required, is style 452D379G02, national stock number 5930-00-732-8401. Internally mounted switch is used to open or close control circuits as breaker operates and is provided with "A" and "B" contacts. "A" contact is normally closed when breaker is closed and open when breaker is open; "B" is normally open when breaker is closed and closed with breaker open. It has the following rating at given voltages: 15 ampere — 125, 250 or 460 volts ac; 1/2 amperes — 125 volts dc; 1/4 ampere — 250 volts dc. Net weight, 0.17 lb. (0.08 kg).

If 2A/2B auxiliary switch is required, order Style 452D379G04, NSN 5930-00-509-2483.

Contact Eaton for other ratings or types of mounting.

## Fungus — Moisture — Resistant Treatments

(JAN-T-152; JAN-C-173 or MIL-V-173): If specified, contact Eaton. External parts are coated; trip units are not treated.

## Technical Manual — NAVSHIPS No. 362-2164

This booklet per MIL-M-15071. When required, order BVR-TM-379A.

## Motor Operator

6590C87G01 — 115 Vac, 60 Hz

## Shunt Trip

Shunt trip attachments for tripping the breaker electrically from a remote point are listed in table below. Shunt trips have momentary rating only and for protection must be connected in series with auxiliary switch. Net weight, 0.70 lb. (0.3 kg) Contact Eaton for 400 Hz. shunt trips.

## SHUNT TRIP ATTACHMENT PRODUCT SELECTION

NOMINAL VOLTAGE	VOLTAGE RANGE	STYLE NUMBER	NATIONAL STOCK NUMBER (NSN)
28 Vdc	26 – 36	452D377G01 ①②	5925-00-831-8802
115 Vac	90 – 130	452D377G01 ①②	5925-00-831-8802
28 Vdc	26 – 36	452D377G02 ①③	5925-00-831-8806
115 Vac	90 – 130	452D377G02 ①③	5925-00-831-8806
120 Vdc	70 – 140	452D377G03 ①②	5925-00-840-1790
450 Vac	360 – 500	452D377G03 ①②	5925-00-840-1790
120 Vdc	70 – 140	452D377G04 ①③	5925-00-831-8807
450 Vac	360 – 500	452D377G04 ①③	5925-00-831-8807
28 Vdc	26 – 36	452D377G05 ②④	5925-00-831-8808
115 Vac	90 – 130	452D377G05 ②④	5925-00-831-8808
28 Vdc	26 – 36	452D377G06 ③④	5925-00-831-8809
115 Vac	90 – 130	452D377G06 ③④	5925-00-831-8809
120 Vdc	70 – 140	452D377G07 ②④	5925-01-007-5836
450 Vac	360 – 500	452D377G07 ②④	5925-01-007-5836
120 Vdc	70 – 140	452D377G08 ③④	5925-00-831-8812
450 Vac	360 – 500	452D377G08 ③④	5925-00-831-8812

- ① These shunt trips require a separate auxiliary switch be ordered.  
 ② These shunt trips are mounted standard right pole with rear leads.

- ③ These shunt trips are mounted left pole with rear leads.  
 ④ These shunt trips already include the required auxiliary switch.

### Undervoltage Device

Automatically trips breaker when line voltage drops below 40 to 60% of normal. After undervoltage coil has dropped out and tripped breaker on reduced voltage, it automatically resets by breaker action. (If undervoltage coil is energized to 80% of normal). Select device from table to the right. Net weight, 1.12 lbs. (0.5 kg).

### UNDERVOLTAGE DEVICE PRODUCT SELECTION

NOMINAL VOLTAGE	VOLTAGE RANGE	PICKUP AND SEAL VOLTS (MINIMUM)	DROPCUT VOLTAGE	STYLE NUMBER ①	NATIONAL STOCK NUMBER
450 ac, 60 Cycle	360 – 500	360	290 Maximum	<b>452D837G01</b>	5925-00-920-3099
450 ac, 60 Cycle	360 – 500	360	45 Minimum	<b>452D837G01</b>	5925-00-920-3099
250 dc	175 – 355	150	25 Minimum	<b>452D837G02</b>	5950-00-501-2065
33 dc	30 – 36	22	5 Minimum	<b>452D837G03</b>	5950-00-790-4869
115 Vac	90 – 135	90	80 Maximum	<b>452D837G04</b>	5925-01-385-2027

① You can't mount a UVR and shunt trip in same breaker; UVR right pole only.

### Individual Reproductions

When required, reproduction of master drawings, outline drawings and certification sheets can be ordered as follows:

### INDIVIDUAL REPRODUCTIONS PRODUCT SELECTION

ITEM	DESCRIPTION
1	Full Size Photolith Tracing of Master Drawing on Vellum
2	Outline and Drilling Plan on Vellum
3	Certification Data on Vellum
4	Reproductions of Items 1, 2 or 3

### Drawings Available

Master drawing 900-J-376; front and rear connected breaker outline, drilling and wiring diagram 452-D-834.

For ordering information, see **Page 5**.

# Types AQB-A250, NQB-A250

## Outline Dimensions AQB-A250 Breaker — Dimensions in Inches

### Note:

The auxiliary switch must be used with each shunt trip. Connect one side of shunt trip in series with "A" contact (Closed when breaker is closed) of auxiliary switch when connecting to power supply.

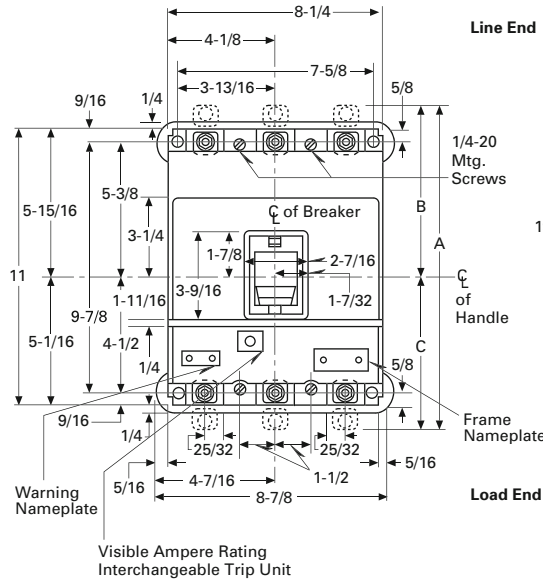

Support Blocks Are Not Supplied With Breaker,  
But Must Be Ordered Separately. Refer to Drawing 313C680.  
All Parts Necessary to Convert a Breaker Are Included

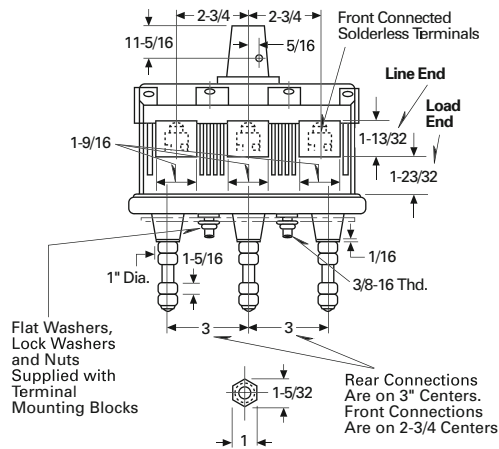
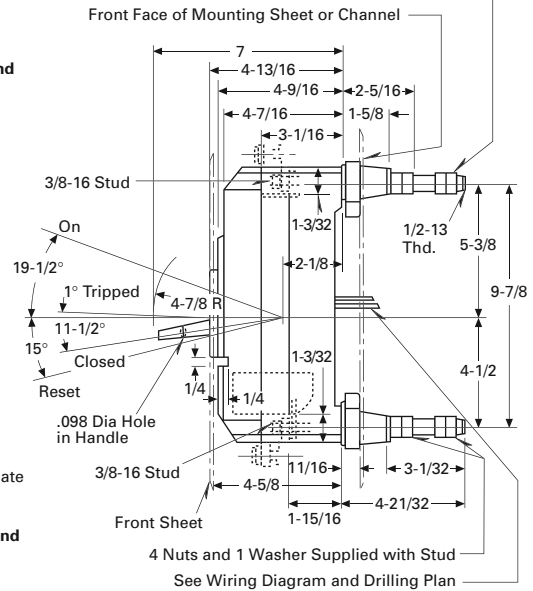

### FRONT CONNECTED SOLDERLESS TERMINALS IDENTIFICATION

CABLE RANGE MCM		A	B	C	STYLE NUMBER
MAXIMUM	MINIMUM				
75	50	12-11/16	6-25/32	5-29/32	20B3055H14
125	100	13	6-15/16	6-1/16	20B3055H15
200	150	13-5/16	7-3/32	6-7/32	20B3055H16

**Note:** Front Connected Terminals are not Supplied with Circuit Breaker.

**Outline Dimensions  
AQB-A250 Breaker —  
Dimensions in Inches**

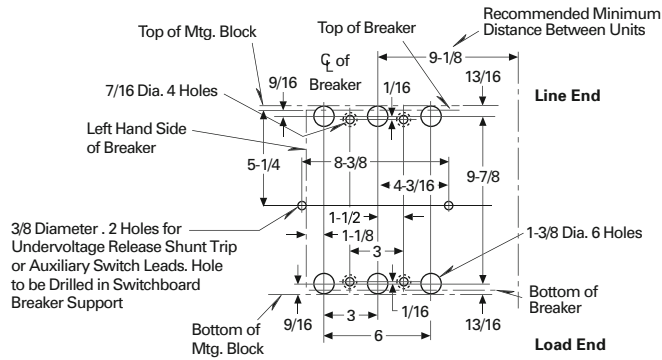

**DRILLING PLAN FOR TERMINAL MOUNTING BLOCKS**

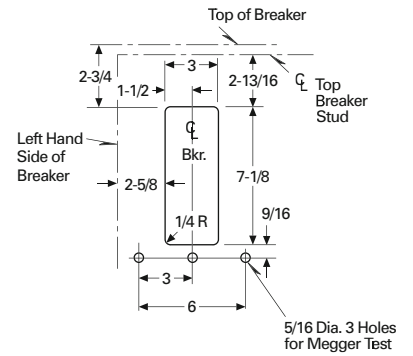

**FRONT SHEET DRILLING TEMPLATE**

**Handle Locking Device  
(Not Supplied with Circuit  
Breaker)**

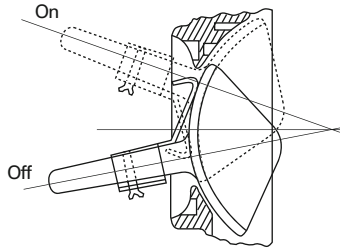

**Wiring Diagrams**

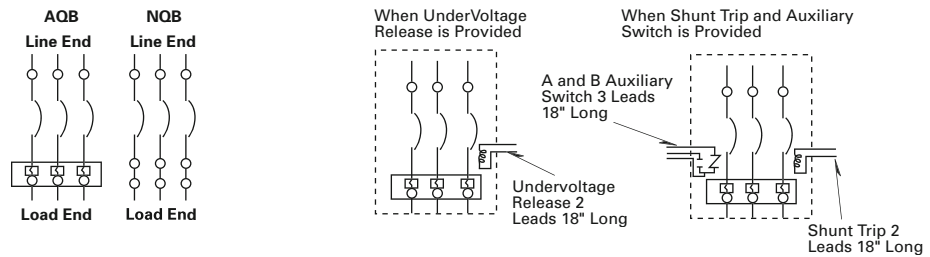

**Note:**  
The auxiliary switch must be used with each shunt trip. Connect one side of shunt trip in series with "A" contact (Closed when breaker is closed) of auxiliary switch when connecting to power supply.



# Types AQB-A250, NQB-A250

## Motor Operator On Navy — Type AQB-A250 and NQB- A250 Molded Case Circuit Breakers



**AQB-A250 on Left With Handle  
Extension and Unmounted Motor  
Operator on Right**

The motor operator is a mechanism for remote circuit breaker ON and OFF switching. The motor operator is mounted to the circuit breaker and provides high speed switching with operating times of approximately 14 cycles (235 milliseconds).

Motor operators for use on the AQB-A250 and NQB-A250 circuit breakers are rated at 115 Vac, 60 Hz, and require a minimum 1 kVA power source. In addition, all motor operators are equipped with an Auto-Reset feature as standard.

The motor operator is designed to remotely switch a circuit breaker to its ON, OFF and relatch positions. The relatch (Auto-Reset) function will occur automatically after a circuit breaker trip operation. The motor operator is self contained and assembled in its own mounting frame which mounts on the front of the circuit breaker. When the ON or OFF remote control button is pressed, current flows to the electric motor which turns a

ball bearing and screw assembly driving the carrier and roller assembly. Two rollers fit over the circuit breaker handle and move with the handle through its range of movement. Limit switches control the travel of the carrier assembly. A terminal block is provided in the mounting frame for control connections. A “b” contact auxiliary switch is provided for installation in the breaker for the Auto-Reset function.

VOLTAGE	STYLE NUMBER	NATIONAL STOCK NUMBER
115 Vac	6590C87G01 ①	6105-01-431-5680

① If 450 Vac required, then customer should supply own minimum 1 kVA step-down transformer per motor operator.

### Net Weight, Lbs. (kg)

Motor Operator 18.00 (8.2).

**Outline Dimensions  
AQB-A250 or NQB-A250  
Circuit Breaker and Motor  
Operator — Dimensions  
in Inches**

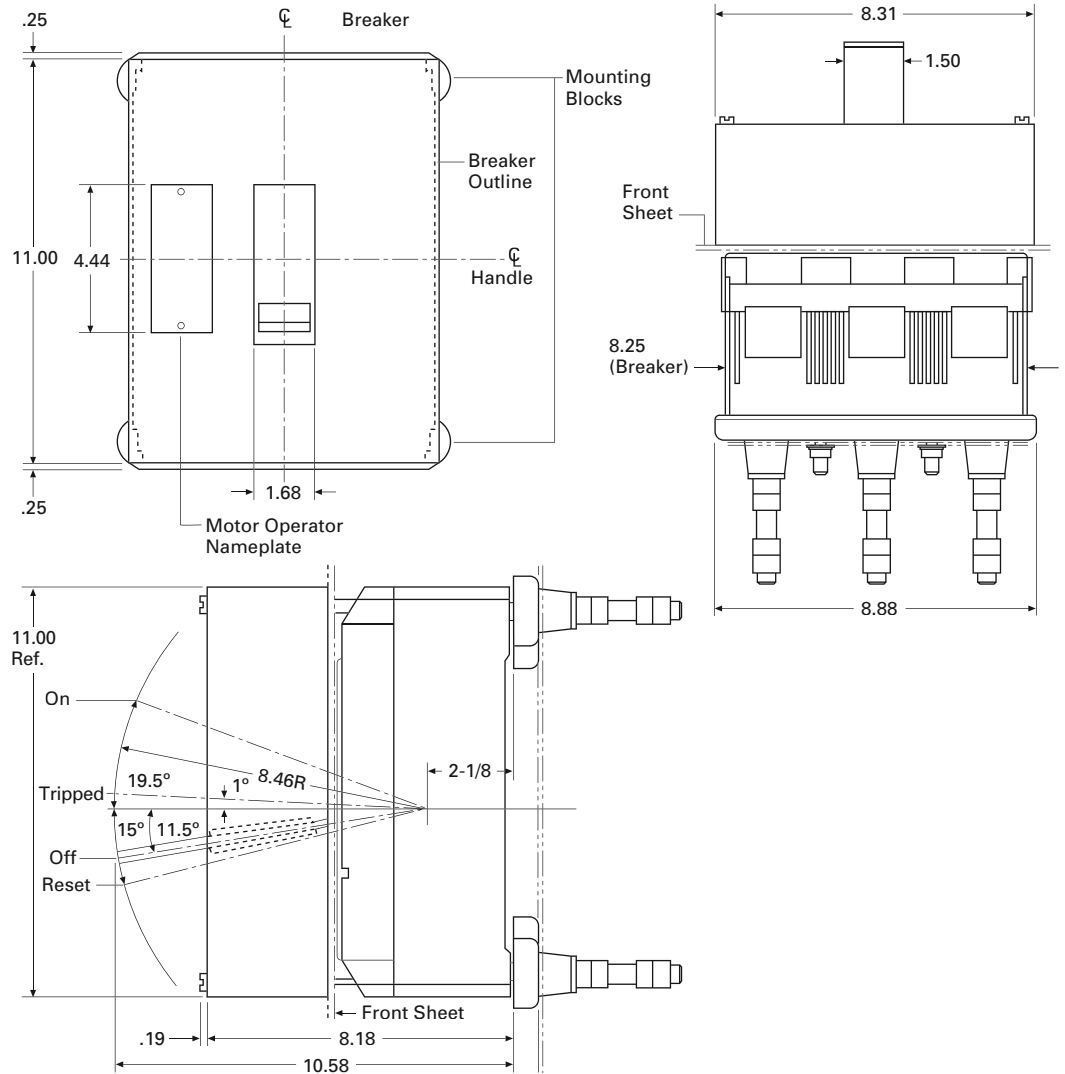

# Types AQB-A250, NQB-A250

## Motor Operator Identification

115 Vac Motor Operator:  
6590C87G01.

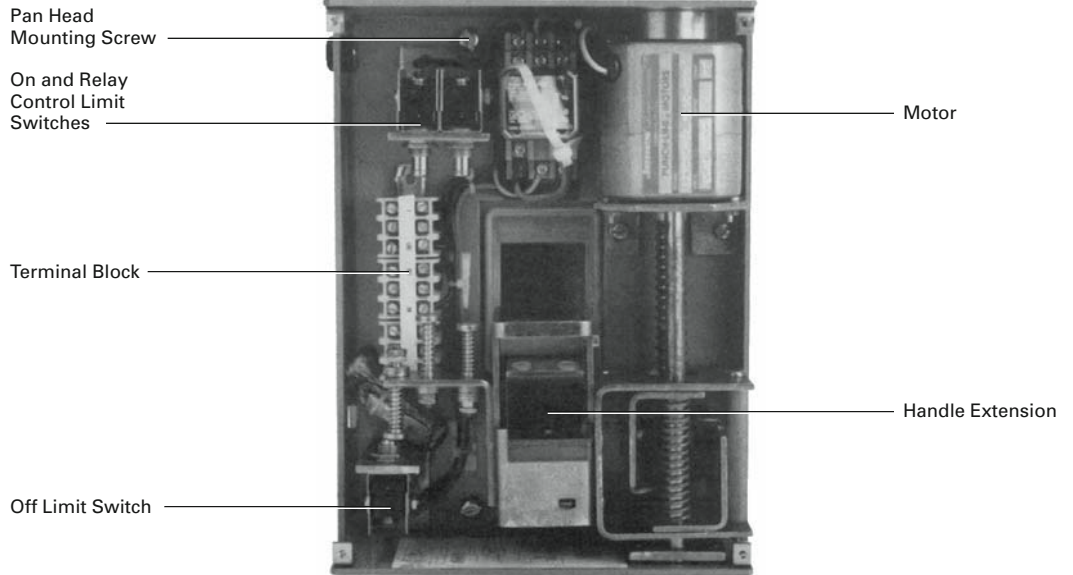

## MOTOR OPERATOR INSTALLED WITH FRONT COVER REMOVED

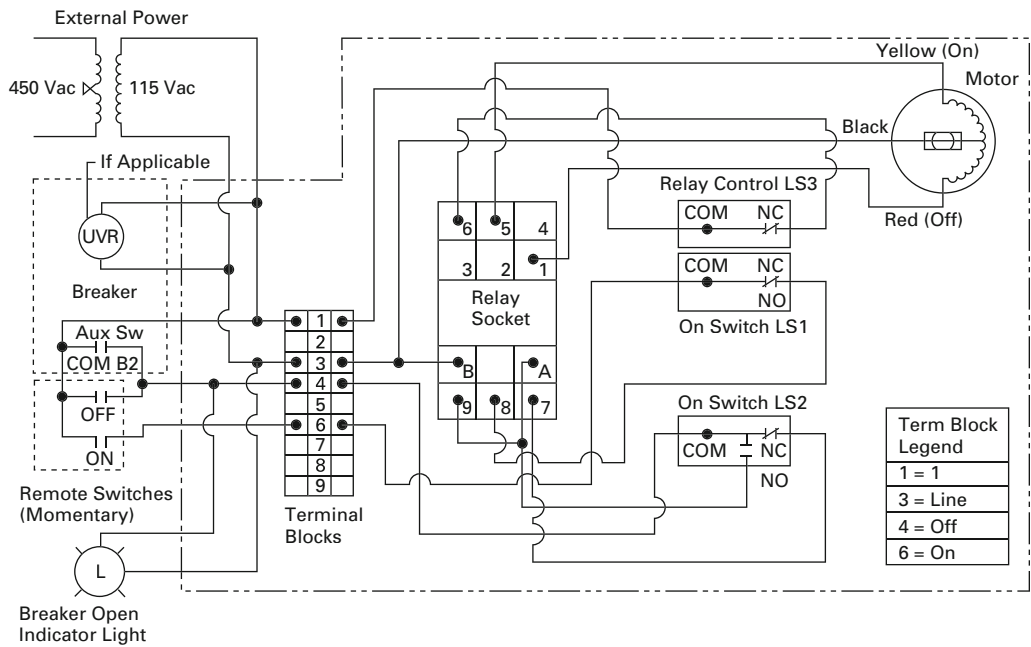

## MOTOR OPERATOR WIRING DIAGRAM

## Characteristic Time-Current Curves

### Specification MIL-C-17361

This specification covers all thermal-magnetic AQB breakers. It requires that they carry 150% of current ratings for at least one hour and that thermal elements initiate tripping at 225% rated current within one hour and at 600% in 25 seconds plus or minus 25%. The instantaneous magnetic settings for each continuous ratings are based on intended applications. (Thermal tripping tests are conducted with all poles in series in 50°C ambient; each pole is tested individually to check magnetic settings.)

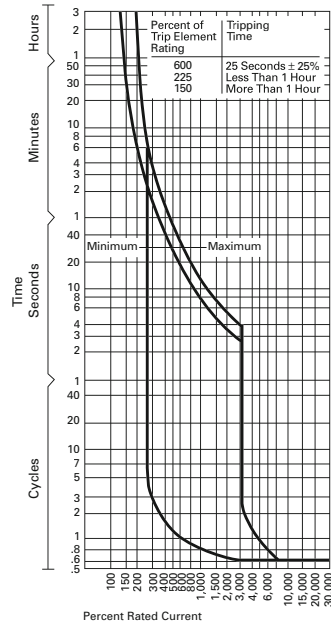

#### AQB-A250

#### Operating Characteristics

Trip Unit Rating 125 – 250  
Amperes 50°C Ambient —  
Cold Start, 60 Cycle, ac or dc.

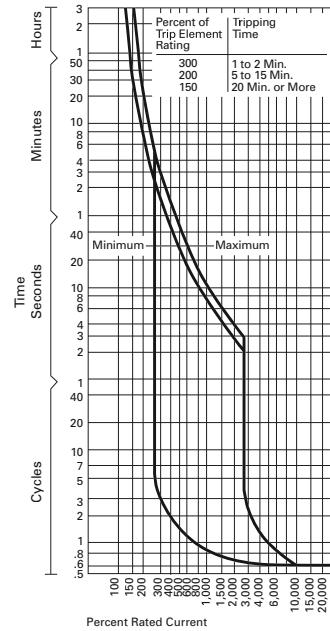

#### AQB-A250 GENERATOR BREAKER

#### Operating Characteristics

Trip Units, Types 100NGH,  
160NGH, 250NGH, 100NG,  
160NG and 250NG for use with  
generator circuit breakers 50°C  
ambient — Cold Start, ac or dc.

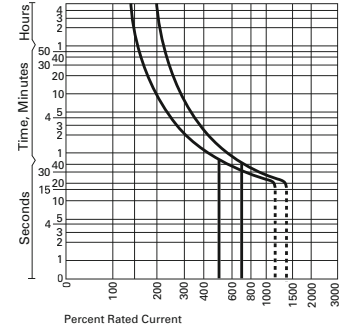

#### 400 CYCLE BREAKERS

#### Operating Characteristics

Trip Unit Rating 125 – 250  
Amperes 50°C Ambient —  
Cold Start, 400 Cycle ac.

#### Trip Unit Rating

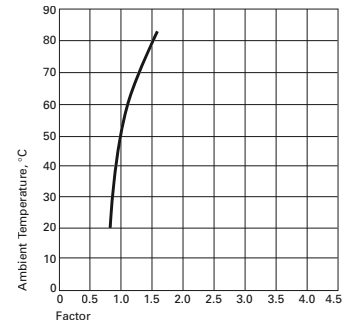

To determine the trip unit rating to be used, when the load current and ambient are known, multiply the load current by the factor obtained from this curve for the known ambient. The result will be the ideal trip unit rating. However, since trip units are furnished only with standard ratings as per Navy spec., select the standard trip unit whose rating is equal to or one rating higher than the ideal rating.

# Types AQB-LF100, AQB-LF250

## Circuit Breakers for Naval Shipboard Use Types AQB-LF100, AQB-LF250 Breakers

Type AQB-LF100, 100 Amperes Maximum, Type AQB-LF250, 250 Amperes Maximum, 500 Volts ac, 100,000 Amperes I.C.



**AQB-LF100 Fused Navy Circuit Breaker**



**AQB-LF250 Fused Navy Circuit Breaker**

### Note:

AQB-LF100 breakers are sold for replacement only. They are no longer on the Navy Qualified Product List.

### Application

AQB-LF100 and AQB-LF250 circuit breakers are for use in low-voltage distribution systems where available fault current exceeds the interrupting ratings of standard molded case breakers but does not exceed 100,000 amperes.

Like standard Navy breakers, they are designed for use in switchboards, loadcenters and panelboards.

AQB-LF circuit breakers are available in three-pole design and for rear connection only.

### Description

These breakers are essentially standard Navy circuit breakers incorporating current limiting fuses in one compact device. The fuses are mounted in a removable molded housing which plugs into and becomes an integral part of the breaker. Fuses are easily replaced from the front simply by loosening four screws and pulling out the fuse housing.

An interlock prevents the breaker from being closed if any of the three fuses are blown and the fuse housing is designed so that all three fuses must be unblown before the housing can be mounted in its correct position on the breaker. Removal of the fuse housing automatically opens breaker and provides visual assurance that the circuit is disconnected.

### Operation

The thermal-magnetic trip unit of the standard breaker provides protection on overloads and short circuits below a predetermined value without affecting the fuses. However, these specially coordinated fuses assume the fault clearing duty on high magnitude short circuits and extend the interrupting capacity to 100,000 amperes.

The common trip feature of the circuit breaker is retained so that all poles open when any fuse blows. Fast acting current limiting fuses clear short circuits in less than one-half cycle. Consequently, peak let-through currents are greatly reduced and bus-supporting members or current carrying parts do not have to be designed to meet maximum peak current.

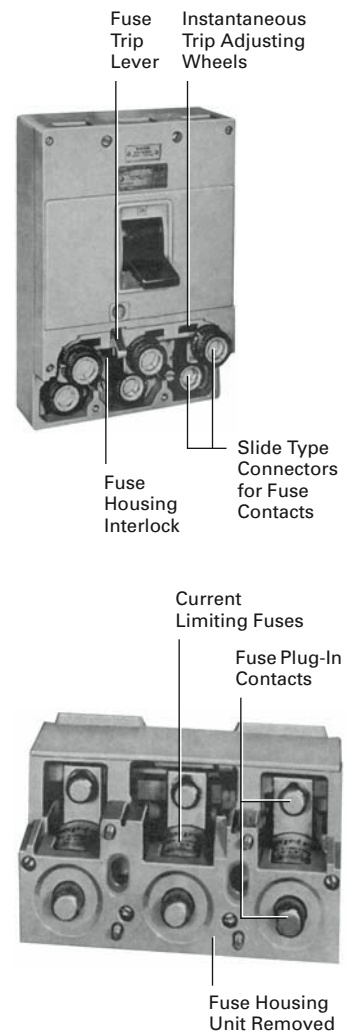

## AQB-LF100 Fused Breaker

### Specification: MIL-C-17361

- 15 – 100 Amperes, 500 Volts ac, 60 Cycles, 3-Pole

### Interrupting Rating

- 100,000 Amperes

### Note:

AQB-LF100 breakers are sold for replacement only. They are no longer on Navy Qualified Product List.

AQB-LF100 breakers are designed for the same application as the AQB-A100 (non-fused) circuit breaker except that they may be applied on circuits where fault currents up to 100,000 amperes are available. Breakers designated by the

suffix “DF” in the table have settings designed for the protection of feeder circuits and those followed by “D” have higher magnetic settings to allow for motor starting.

## AQB-LF100 FUSED BREAKER PRODUCT SELECTION <sup>①</sup>

CONTINUOUS AMPERE RATING	INSTANTANEOUS TRIP SETTING — AMPERES		BREAKER COMPLETE	BREAKER FRAME <sup>②</sup>	NATIONAL STOCK NUMBER	TRIP UNIT	NATIONAL STOCK NUMBER	FUSES	QUANTITY REQUIRED
	LOW	HIGH	STYLE NUMBER <sup>③</sup>	STYLE NUMBER		STYLE NUMBER		STYLE NUMBER <sup>③</sup>	
<b>3-Pole 500 Volts ac</b>									
15-DF	90	105	<b>452D391G16</b>	<b>452D390G02</b>	5925-00-617-8312	<b>452D385G13</b>	5925-00-849-8481	<b>313C743H02</b>	3
15-D	180	210	<b>452D391G17</b>	<b>452D390G02</b>	5925-00-617-8312	<b>452D384G13</b>	5925-00-655-1156	<b>313C743H02</b>	3
25-DF	180	210	<b>452D391G18</b>	<b>452D390G02</b>	5925-00-617-8312	<b>452D385G15</b>	5925-00-655-1157	<b>313C743H02</b>	3
25-D	300	350	<b>452D391G19</b>	<b>452D390G02</b>	5925-00-617-8312	<b>452D384G15</b>	5925-00-655-1158	<b>313C743H02</b>	3
50-DF	300	350	<b>452D391G20</b>	<b>452D390G02</b>	5925-00-617-8312	<b>452D385G17</b>	5925-00-655-1159	<b>313C743H03</b>	3
50-D	600	700	<b>452D391G21</b>	<b>452D390G02</b>	5925-00-617-8312	<b>452D384G17</b>	5925-00-655-1160	<b>313C743H03</b>	3
75-DF	450	525	<b>452D391G22</b>	<b>452D390G02</b>	5925-00-617-8312	<b>452D385G20</b>	5925-00-655-1161	<b>313C743H03</b>	3
75-D	900	1050	<b>452D391G23</b>	<b>452D390G02</b>	5925-00-617-8312	<b>452D384G20</b>	5925-00-655-1162	<b>313C743H03</b>	3
100-DF	600	700	<b>452D391G24</b>	<b>452D390G02</b>	5925-00-617-8312	<b>452D385G23</b>	5925-00-655-1163	<b>313C743H03</b>	3
100-D	1200	1400	<b>452D391G25</b>	<b>452D390G02</b>	5925-00-617-8312	<b>452D384G23</b>	5925-00-655-1164	<b>313C743H03</b>	3

<sup>①</sup> For list prices, see Price and Availability Digest (PAD).

<sup>②</sup> Breaker frame consists of frame with its fuse housing unit and slip-type connectors for back connection, but does not include trip unit, fuses or mounting blocks. Order these separately, trip units and fuses from table above and mounting blocks from listings below.

<sup>③</sup> National stock number as follows:  
313C743H02 = 5920-00-628-7792  
313C743H03 = 5920-00-628-7793

## Switchboard Mounting

Breaker frame includes mounting hardware. Female slip connectors are mounted on the rear for plugging onto stud projections of terminal mounting block assemblies. Order one for each end of the breaker.

DESCRIPTION	STYLE NUMBER	NATIONAL STOCK NUMBER
One Stud Assembly Complete with 4 Nuts	<b>1631 442</b>	5940-00-501-9120
Terminal Mounting Block (No Studs)	<b>1764 240</b>	—
Mounting Block and Stud Set (3 Studs)	<b>01A4457G23</b>	—

# Types AQB-LF100, AQB-LF250

## AQB-LF100 Fused Breaker

### Additions

#### Individual Reproductions

When required, reproductions of master drawings, outline drawings and certification sheets can be ordered as follows:

ITEM	DESCRIPTION
1	Full Size Photolithographic Tracing of Master Drawing on Vellum
2	Outline and Drilling Plan on Vellum
3	Certification Data on Vellum
4	Reproduction of Items 1, 2 or 3

### Drawings Available

Master drawing 900J377; outline drilling plan and wiring diagram 451D711.

### Handle Lock (For Shipboard Maintenance Use Only)

Order style number 1614 485.

### Fungus-Moisture-Resistant Treatments (JAN-T-152; JAN-C-173 or MIL-V-173)

If specified, contact Eaton. External parts are coated; trip units are not treated.

### Technical Manual

Cutler-Hammer NAVSHIPS number 362-2166. This booklet per MIL-M-15071. When required, order BVR-TM-380.

### FUSE HOUSING UNIT (NO FUSES)

STYLE NUMBER	NATIONAL STOCK NUMBER
313C742G01	6605-00-799-3521

### NET WEIGHT

DESCRIPTION	NET WEIGHT, LBS. (KG)
AQB Breaker Complete 3-Pole	13.62 (6.2)
AQB Breaker Frame Only Complete With Fuse Unit Assembly Without Fuses	9.68 (4.4)
Trip Unit 3-Pole	2.62 (1.2)
Fuse Unit Assembly Without Fuses	1.62 (0.7)
One Mounting Block With 3 Studs	1.62 (0.7)
Current Limiting Fuse	0.45 (0.2)
Circuit Breaker Handle Locking Device	0.25 (0.1)

## AQB-LF250 Fused Breaker

### Specification: MIL-C-17361

- 125 – 250 amperes, 500 volts ac, 60 cycles, 3-pole.

### Interrupting Rating

- 100,000 amperes.

These fused breakers are designed for applications similar to those for AQB-A250 (non-fused). However, because of their current limiting fuses, they can be applied on circuits with available fault currents up to 100,000 amperes.

Undervoltage release devices, shunt trips and/or auxiliary switches are available for the AQB-LF250 and can be easily installed in the field.

Those breakers identified by the suffix "LM" in the table have higher magnetic settings for motor starting while those carrying the suffix "L" are set for the protection of feeder circuits

## AQB-LF100 AND AQB-LF250 CIRCUIT BREAKER PRODUCTION SELECTION ①

CONTINUOUS AMPERE RATING	INSTANTANEOUS TRIP SETTING — AMPERES		BREAKER COMPLETE		BREAKER FRAME ②		TRIP UNIT		FUSES	
	LOW	HIGH	STYLE NUMBER	NATIONAL STOCK NUMBER	STYLE NUMBER	NATIONAL STOCK NUMBER	STYLE NUMBER	NATIONAL STOCK NUMBER	STYLE NUMBER ①	QUANTITY REQUIRED
<b>3-Pole 500 Volts ac (Refer to Eaton for 2-Pole Styles and Prices)</b>										
125-L	650	1300	<b>313C748G18</b>	5925-01-360-8673	<b>452D820G02</b>	5925-00-617-8313	<b>452D821G18</b>	5925-00-655-1165	<b>313C743H04</b>	3
125-LM	1500	3000	<b>313C748G19</b>	5925-01-233-5623	<b>452D820G02</b>	5925-00-617-8313	<b>452D821G19</b>	5925-00-655-1166	<b>313C743H04</b>	3
150-L	650	1300	<b>313C748G20</b>	5925-00-998-1960	<b>452D820G02</b>	5925-00-617-8313	<b>452D821G20</b>	5925-00-655-1167	<b>313C743H04</b>	3
150-LM	1500	3000	<b>313C748G21</b>	5925-01-229-4444	<b>452D820G02</b>	5925-00-617-8313	<b>452D821G21</b>	5925-00-655-1168	<b>313C743H04</b>	3
175-L	650	1300	<b>313C748G22</b>	5925-01-189-9250	<b>452D820G02</b>	5925-00-617-8313	<b>452D821G22</b>	5925-00-655-1169	<b>313C743H04</b>	3
175-LM	1500	3000	<b>313C748G23</b>	5925-01-507-2391	<b>452D820G02</b>	5925-00-617-8313	<b>452D821G23</b>	5925-00-655-1170	<b>313C743H04</b>	3
225-L	650	1300	<b>313C748G24</b>	5925-01-233-5173	<b>452D820G02</b>	5925-00-617-8313	<b>452D821G24</b>	5925-00-655-1171	<b>313C743H04</b>	3
225-LM	1500	3000	<b>313C748G25</b>	5925-01-378-1838	<b>452D820G02</b>	5925-00-617-8313	<b>452D821G25</b>	5925-00-655-1172	<b>313C743H04</b>	3
250-L	650	1300	<b>313C748G26</b>	5925-01-243-1611	<b>452D820G02</b>	5925-00-617-8313	<b>452D821G26</b>	5925-00-655-1174	<b>313C743H04</b>	3
250-LM	1500	3000	<b>313C748G27</b>	5925-01-434-3687	<b>452D820G02</b>	5925-00-617-8313	<b>452D821G27</b>	5925-00-655-1173	<b>313C743H04</b>	3
			<b>Net Weight 32.00 Lbs. (14.5 kg)</b>		<b>Net Weight 24.50 Lbs. (11.1 kg)</b>		<b>Net Weight 3.00 Lbs. (1.4 kg)</b>		<b>Net Weight 1.50 Lbs. (0.7 kg)</b>	

① For list prices, see Price and Availability Digest (PAD).

② Breaker frame consists of frame with its fuse housing unit and slip-type connector for back connection, but does not include trip unit, fuses or mounting blocks. Order these separately, trip units from table above and mounting blocks from listings above.

① National stock number 5920-01-295-0107.

## Switchboard Mounting

Breaker frame includes mounting hardware. Female slip connectors are mounted on the rear for plugging onto stud projections of terminal mounting block assemblies. Order one for each end of the breaker.

DESCRIPTION	STYLE NUMBER	NATIONAL STOCK NUMBER
One Stud Assembly Complete with 4 Nuts	<b>1631 443</b>	5940-00-501-9119
Terminal Mounting Block (No Studs)	<b>313C681G01</b>	2920-01-354-4811
Mounting Block and Stud Set (3 Studs)	<b>313C680G02</b>	5940-01-146-6806



# Types AQB-LF100, AQB-LF250

## Additions

### Individual Reproductions

When required, reproductions of master drawings, outline drawings and certification sheets can be ordered as follows:

ITEM	DESCRIPTION
1	Full Size Photolith Tracing of Master Drawing on Vellum
2	Outline and Drilling Plan on Vellum
3	Certification Data on Vellum
4	Reproduction of Items 1, 2 or 3

### Drawings Available

Master drawing 900-J-379; breaker outline, drilling plan and wiring diagram 451D250.

### Handle Lock (For Shipboard Maintenance Use Only)

Order style number 28B4596G01.

### Auxiliary Switch

For description, see AQB-A250 breaker **Page 52**. Style number 452D379G02 same as for AQB-A250. Net weight .17 lbs. (0.08 kg).

### Shunt Trip Attachment

To order refer to AQB-A250 breaker on **Page 52**. Style numbers and net prices are same as those for AQB-A250. Net weight .70 lbs. (0.3 kg).

### Undervoltage Device

To order, refer to AQB-A250 breaker on **Page 52**. Style numbers and list prices are same as those for AQB-A250. Net weight 1.12 lbs. (0.5 kg).

### Technical Manual

NAVSHIPS number 362-2165. This booklet per MIL-M-15071. When required, order BVR-TM-381.

### FUSE HOUSING UNIT (NO FUSES)

STYLE NUMBER	NATIONAL STOCK NUMBER	NET WEIGHT, LBS. (KG)
452D832G01	5920-01-218-3803	4.50 (2.0)

### Ordering Information

See **Page 5**.

### Net Weights

See table above.

**Outline Dimensions  
AQB-LF100 Breakers —  
Dimensions in Inches**

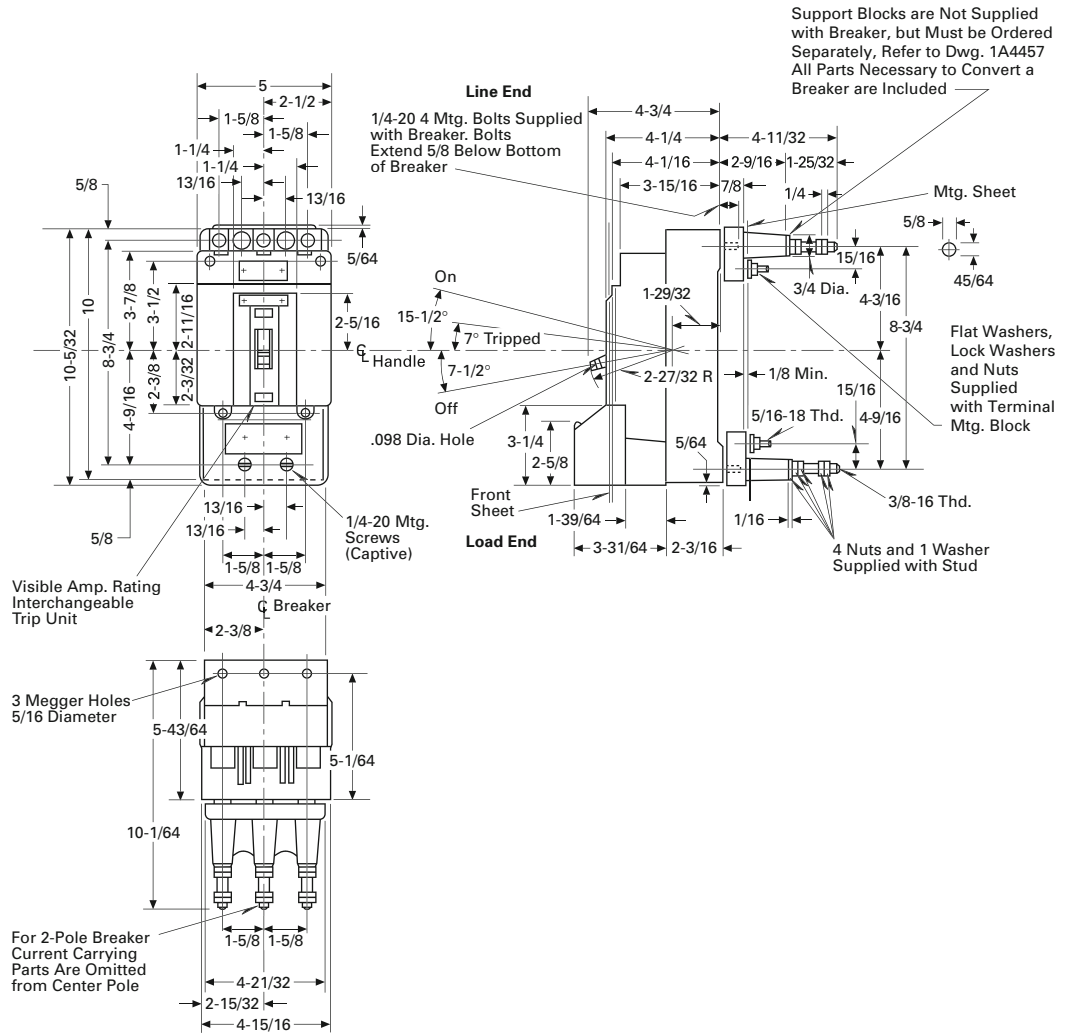

**Slip Contact Assembly**

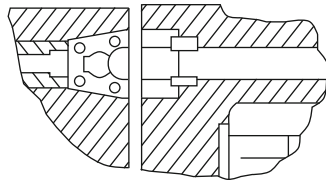

# Types AQB-LF100, AQB-LF250

## Typical Wiring Diagram

Wiring as Shown for 3-Pole Breaker. For 2-Pole Breaker Omit Middle Pole.

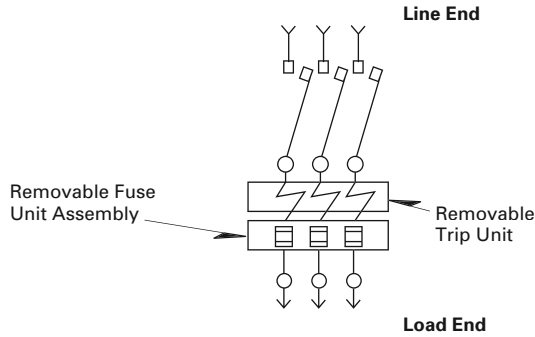

## Drilling Plans and Cutout

For Terminal Mounting Blocks Front Sheet Drilling Template.

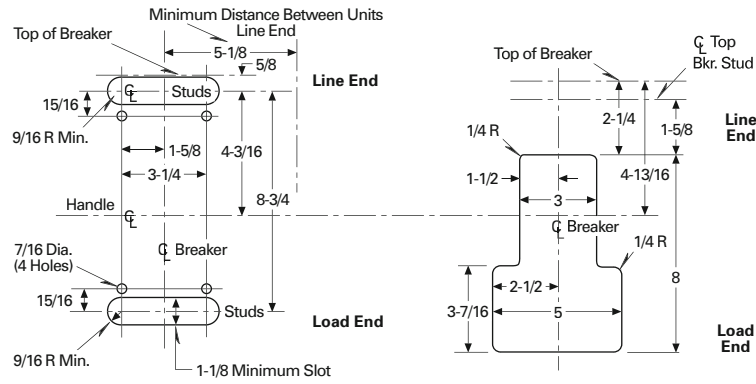

**DRILLING PLANS**

**FRONT COVER CUTOUT**

## Circuit Breaker Handle Locking Device

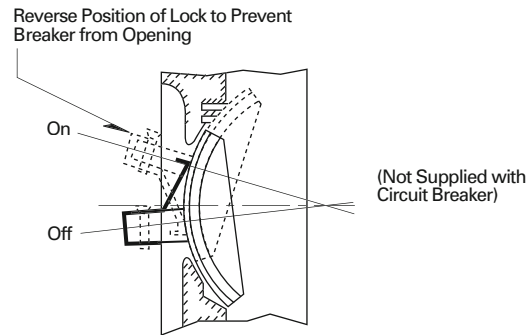

**Outline Dimensions  
AQB-LF250 Breakers —  
Dimensions in Inches**

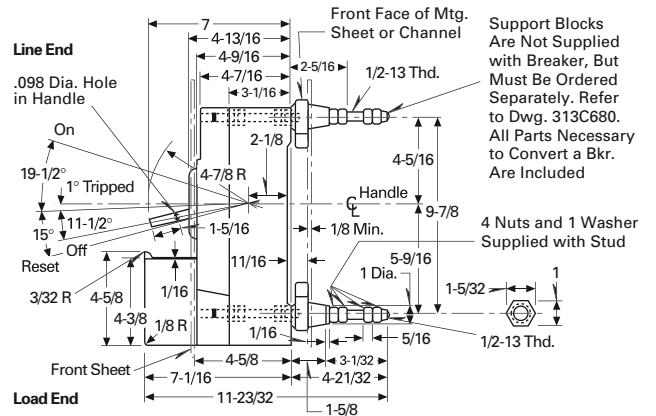
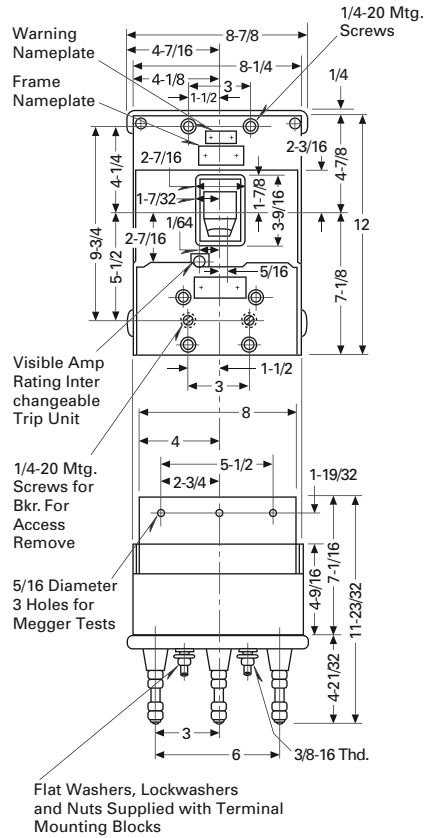

**Typical Wiring Diagram**

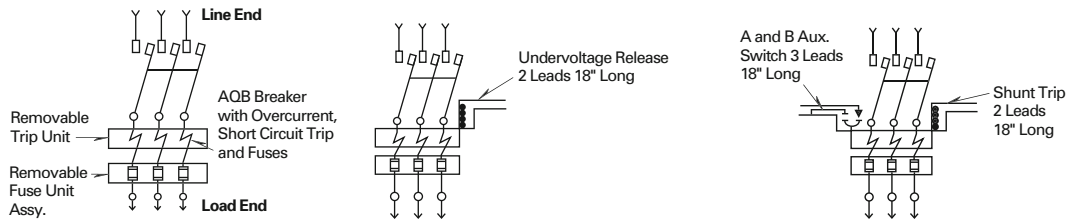

**WIRING AS SHOWN FOR 3-POLE BREAKER; FOR 2-POLE BREAKER, OMIT MIDDLE POLE**

**WHEN UNDERVOLTAGE RELEASE IS PROVIDED**

**WHEN SHUNT TRIP AND AUXILIARY SWITCH IS PROVIDED**

# Types AQB-LF100, AQB-LF250

## Outline Dimensions AQB-LF250 Breakers — Dimensions in Inches

### Drilling Plans

For Terminal Mounting Blocks  
Front Sheet Drilling Template.

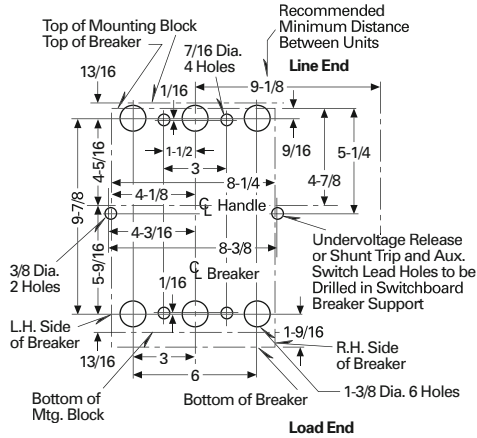

FOR TERMINAL MOUNTING BLOCKS

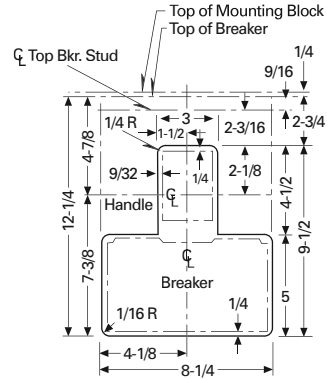

FRONT SHEET DRILLING TEMPLATE

### Handle Locking Device

(Not Supplied With Circuit  
Breaker.)

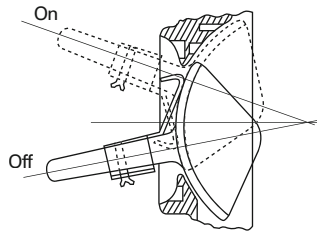

### Note:

The auxiliary switch must be used with each shunt trip, connect one side of shunt trip in series with "A" contact (closed when breaker is closed) of auxiliary switch when connecting to power supply.

## Characteristic Time-Current Curves AQB-LF100 and AQB-LF250 Breakers

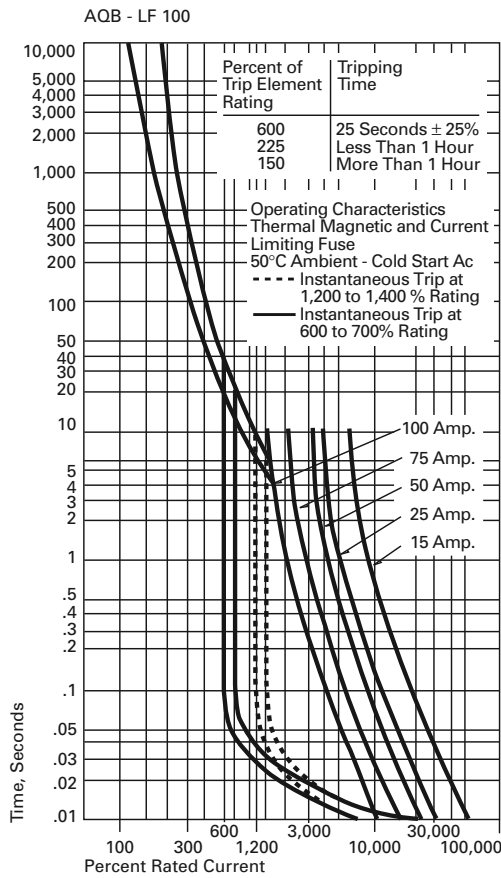

**AQB-LF100 BREAKERS**

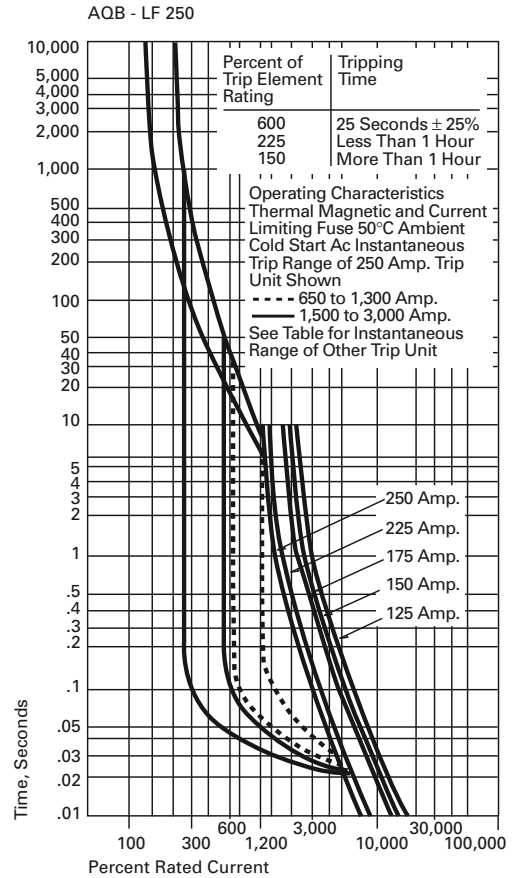

**AQB-LF250 BREAKERS**

### Trip Unit Rating

To determine the trip unit rating to be used, when the load current and ambient are known, multiply the load current by the factor obtained from the curve to the right for the known ambient. The result will be the ideal trip unit rating. However, since trip units are furnished only with standard ratings as per Navy spec., select the standard unit trip whose rating is equal to or one rating higher than the ideal rating.

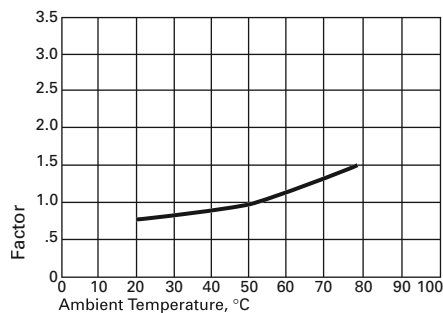

# Types AQB-A253, AQB-L253 and NQB-A253

## Circuit Breakers for Naval Shipboard Use — Types AQB-A253, AQB-L253, NQB-A253

500 Volts ac, 250 Amperes  
Maximum, A253 — 30,000  
Amperes I.C. and L253 —  
100,000 Amperes I.C. Breakers



### Specifications: MIL-C-17361

- 100 – 250 amperes, 100% Rated.
- AQB-A253: 500 volts ac, 60/400 Hz.
- AQB-L253: 500 volts ac, 60 Hz.
- NQB-A253: 500 volts ac, 60/400 Hz.
- No dc.
- Interchangeable Electronic Trip with rms sensing.
- 3-pole.

### Interrupting Rating

- AQB-A253: 30,000 amperes, 60 Hz ac.
- 10,000 amperes, 400 Hz ac.
- AQB-L253: 100,000 amperes, 60 Hz ac.
- NQB-A253: Non Overcurrent Protection.
- Class: Hi shock MIL-S-901D, 50°C ambient.

### Description

The AQB-A253, 250 ampere circuit breaker, is form and fit interchangeable with the AQB-A250 but has an electronic trip unit and higher interrupting capacity. It is available in a 3-pole, ac current version only. If used to protect two ac poles, connect only the outer poles. It is a universal style with a common trip unit and 60 Hz and 400 Hz ratings.

The AQB-L253 is a high interruption version of the AQB-A253 in the same external package. It uses fuseless current-limiting technology to achieve 100 kA interrupting capacity so it can be used to replace the AQB-LF250 without the logistic concerns of fuse replacement. The AQB-L253 utilizes a smaller package and offers a significant weight reduction compared to the LF250. The -L253 is available in only a 60 Hz version.

The NQB-A253 circuit breaker has a maximum continuous current rating of 250 amperes. They are used only as disconnects, since they do not include an automatic opening device.

The AQB-A253 and L253 are supplied with a universal trip unit that is used in all AQB versions. The trip unit must be equipped with an adjustable rating plug (ordered separately) that determines the continuous current rating of the complete circuit breaker. Two adjustable rating plugs are available. One covers the continuous current settings of 250, 225, 200 and 175 amperes and the other covers the current settings of 160, 150, 125 and 100 amperes.

The interchangeable electronic trip unit (ETU) has an adjustable time-current curve with selectable values of Short Time Delay Pickup (STDPU) (scaled to the CCS) and Short Time Delay (STD) for improved coordination with upstream or downstream devices. The trip unit also has an instantaneous override trip fixed at 7500 A (30 x frame rating). The ETU can emulate the trip curve of the AQB-A250 by setting the STD to INST and using the STDPU to emulate an adjustable INST setting.

### Principle of Operation

These circuit breakers are designed to provide the most modern form of low voltage circuit protection technology available, providing high interruption ratings and flexible coordination without the need for current limiting fuses. The breakers use modern electromagnetic design principles to increase the interrupting capacity (IC) to significantly higher levels than comparable AQB-A250 breakers. The AQB-L253 uses a “reverse loop” conductor design and “magnetically unlatched” contact arms to provide very high interrupting capacity while limiting the let-through current and limiting the fault duration to a few milliseconds.

### Ordering

The circuit breaker is available in three styles, an AQB-A253 (standard IC), an AQB-L253 (high IC) and an NQB-A253 (non-automatic) switch. The breaker is completed by adding one of two styles of rating plugs, one which covers the continuous current range from 250 – 175 amperes and another which covers the range from 160 – 100 amperes. An internally mounted auxiliary switch, a shunt trip and an under-voltage release are also available.

### AQB-A253, AQB-L253 Characteristics

#### Continuous Current Setting (4-Position Selector Switch) —

100 – 160 amperes (100, 125, 150, 160) rating plug

175 – 250 amperes (175, 200, 225, 250) rating plug

**Instantaneous Pickup** — Fixed at 30 X Frame rating (7500 A).

**Short Delay Pickup** — Adjustable in multiples of continuous current settings (2x, 3x, 4x, 6x, 8x, 10x, 12x, 13x).

**Short Time Delay** — Adjustable flat response with bands:

- INST (.025 – .050 seconds).
- 0.100 seconds (.058 – .083 seconds).
- 0.200 seconds (.158 – .183 seconds).
- 0.300 seconds (.258 – .283 seconds).

**AQB-A253, AQB-L253 AND NQB-A253 CIRCUIT BREAKER PRODUCT SELECTION** ①

BREAKER	COMPLETE BREAKER		FRAME ONLY		TRIP UNIT ONLY	
	STYLE NUMBER	NATIONAL STOCK NUMBER	STYLE NUMBER	NATIONAL STOCK NUMBER	STYLE NUMBER	NATIONAL STOCK NUMBER
<b>Standard LSI</b>						
AQB-A253	<b>1483D82G03</b>	5925-01-493-8105	<b>1483D82G01</b>	5925-01-495-3022	<b>1483D73G04</b>	5925-01-481-5874
AQB-L253	<b>1483D82G04</b>	5925-01-532-5569	<b>1483D82G02</b>	5925-01-481-5876	<b>1483D73G04</b>	5925-01-481-5874
<b>Instantaneous Only</b>						
AQB-A253	<b>1483D82G13</b>	—	<b>1483D82G01</b>	5925-01-495-3022	<b>1483D73G07</b>	—
AQB-L253	<b>1483D82G14</b>	—	<b>1483D82G02</b>	5925-01-483-1953	<b>1483D73G07</b>	—
<b>Non-Automatic</b>						
NQB-A253	<b>1483D82G06</b>	5925-01-548-7748	<b>1483D82G01</b>	5925-01-495-3022	<b>1483D73G06</b>	—

① For list prices, see Price and Availability Digest (PAD).

**FRONT-CONNECTED BREAKER (COMPLETE WITHOUT LUGS)** ②

BREAKER	STYLE NUMBER	NATIONAL STOCK NUMBER
AQB-A253	<b>1483D82G09</b>	5925-01-527-6915
AQB-L253	<b>1483D82G10</b>	5925-01-554-4936
NQB-A253	<b>1483D82G11</b>	5925-01-527-6914

② For list prices, see Price and Availability Digest (PAD).

**FRONT-CONNECTED BREAKER (COMPLETE WITH LUGS)** ③

BREAKER	STYLE NUMBER	NATIONAL STOCK NUMBER
NQB-A253	<b>1483D82G12</b>	—
AQB-L253	<b>1483D82G15</b>	—
AQB-A253	<b>1483D82G16</b>	—

③ For list prices, see Price and Availability Digest (PAD).

**ADJUSTABLE RATING PLUG** ④

AMPERE RATING	STYLE NUMBER	NATIONAL STOCK NUMBER
100 – 160	<b>6603C02G52</b>	5935-01-481-2133
175 – 250	<b>6603C02G51</b>	5935-01-481-2131

④ For list prices, see Price and Availability Digest (PAD).

**Note:**  
Please contact Technical Resource Center for specialty part number with accessories factory installed.

**Note:**  
AIC ratings are based on 3-phase average asymmetrical current.



# Types AQB-A253, AQB-L253 and NQB-A253

## Circuit Breaker Mounting Blocks

Complete circuit breaker includes mounting hardware. Female slip connectors are included in the breaker base to

plug onto stud projections on the front of terminal mounting block assemblies; these mounting blocks must be ordered separately. Order two mounting block assembly for each breaker.

DESCRIPTION	STYLE NUMBER	NATIONAL STOCK NUMBER	NET WEIGHT, LBS. (KG)
Mounting Block and Stud Set (3 Studs)	313C680G02	5940-01-146-6806	1.5 (0.7)
Terminal Mounting Block (No Studs)	313C681G01	2920-01-354-4811	1.0 (0.5)
One Stud Assembly Complete with 4 nuts	1631443	—	1.0 (0.5)

## Front-Connected Circuit Breakers

For cable connections made at front terminals, pressure-type lugs are required. If specified on

order, connectors will be furnished at no charge and "tulips" removed. Use one connector per terminal. Select from the table below.

DESCRIPTION	CABLE RANGE	AMPERES	STYLE NUMBER	NATIONAL STOCK NUMBER
Solderless Connector	N40-N70	125	20B3055H14	5925-01-414-2467
	N100-N125	150 – 175	20B3055H15	5925-01-429-4972
	N150-N200	250	20B3055H16	5925-01-413-1588

## Auxiliary Switch

The auxiliary switch (AS) changes state with the circuit breaker. Auxiliary switches supplied with this breaker are form C (SPDT) with 3 lead wires.

The "a" (normally open) contact mimics the action of the main contacts and the "b" (normally closed) contact is opposite. This switch is mounted in the right pole of the circuit breaker and must be factory installed.

DESCRIPTION	STYLE NUMBER	NATIONAL STOCK NUMBER	NET WEIGHT, LBS. (KG)
Auxiliary Switch, 1a/1b, 115 Vac, 10 Amperes	1483D90G01	5930-01-558-9236	0.5 (0.2)
Auxiliary Switch, 2a/2b, 115 Vac, 10 Amperes	1483D90G02	5930-01-559-4835	0.5 (0.2)

### Shunt Trip

The Shunt Trip (ST) is provided to remotely trip (open) the circuit breaker in response to a remote signal applied to the accessory device. It is available in a variety of voltage ratings (see below).

It is a momentary device that draws power briefly and then is disconnected by an integral cutoff switch (included). It is mounted in the left pole of the breaker and can be installed only in the absence of an undervoltage release.

NOMINAL VOLTAGE	STYLE NUMBER	NATIONAL STOCK NUMBER	NET WEIGHT, LBS. (KG)
115 Vac, 50/60 Hz	1483D92G03	5925-01-481-5863	0.5 (0.2)
115 Vac, 400 Hz	1483D92G04 <sup>①</sup>		0.5 (0.2)
450 Vac, 50/60 Hz	1483D92G05	5925-01-515-6353	0.5 (0.2)
28 Vdc	1483D92G01	5925-01-559-6023	0.5 (0.2)
120 Vdc	1483D92G02	5925-01-558-9230	0.5 (0.2)
250 Vdc	1483D92G06		0.5 (0.2)

<sup>①</sup> Please check with Eaton for availability.

### Undervoltage Release

The undervoltage release (UVR) will trip the circuit breaker and hold it in a tripped condition if the control voltage to the UVR drops below 40% to 60% of nominal. After the UVR has tripped the breaker it will be mechanically reset by the opening action of

the breaker and electromagnetically latched if the applied voltage returns to at least 80% of nominal. It mounts in the left pole of the circuit breaker cover and can only be used in the absence of a shunt trip device.

**FACTORY INSTALL ONLY.**

NOMINAL VOLTAGE	STYLE NUMBER	NATIONAL STOCK NUMBER	NET WEIGHT, LBS. (KG)
115 Vac, 50/60 Hz	1483D91G01	—	0.5 (0.2)
450 Vac, 50/60 Hz	1483D91G02	—	0.5 (0.2)
120 Vdc	1483D91G03	—	0.5 (0.2)
250 Vdc	1483D91G04	—	0.5 (0.2)

### AQB-LF250 Adapter Plate

This close-out plate is required when the AQB-L253 is used to replace an existing AQB-LF250

circuit breaker. The plate closes the hole in the switchboard or panelboard where the fuse pack of the -LF250 protruded.

DESCRIPTION	STYLE NUMBER	NATIONAL STOCK NUMBER	NET WEIGHT, LBS. (KG)
AQB-LF250 Close-out Plate	6603C76G01	5895-01-483-1936	0.14 (0.1)

# Types AQB-A253, AQB-L253 and NQB-A253

Master Drawing 1483D48.

## Motor Operator

An electrical motor operator is available which mounts on the front face of the circuit breaker and can be used for remotely opening or closing the breaker.

It provides high speed actuation with operating times of approximately 10 cycles (0.17 seconds). Motor operators for the -A253 or -L253 are rated at 120 Vac but can be used at 450 Vac with a customer-supplied 1 kVA step-

down transformer. A handle extension is also provided for installation on the circuit breaker handle. Eaton recommends a minimum 1 kVA power source for each motor operator.

NOMINAL VOLTAGE	STYLE NUMBER	NATIONAL STOCK NUMBER	NET WEIGHT, LBS. (KG)
120 Vac/Vdc, 60/400 Hz	1483D93G01	5925-01-542-4620	22.0 (10.0)

## Handle Lock

A handle lock can be furnished to lock the handle in either the ON

or OFF position if required. It consists of a special bracket held in place with a cotter pin.

DESCRIPTION	STYLE NUMBER	NATIONAL STOCK NUMBER	NET WEIGHT, LBS. (KG)
Handle Lock	1720101	—	0.15 (0.07)
Handle Extension	5103A34G01		

## Trip Unit Tester

A portable tester can be used to functionally check the circuit breaker and trip unit for overload

and short circuit trip settings. The test port is located on the front of the trip unit and can be accessed while the circuit breaker is mounted.

This test kit is common to all Navy circuit breakers with electronic trip units.

DESCRIPTION	STYLE NUMBER	NATIONAL STOCK NUMBER	NET WEIGHT, LBS. (KG)
STK-2 Portable Test Kit	1232C50G10	6625-01-419-1910	—

## RECOMMENDED BREAKER AND ACCESSORY HARDWARE TORQUE VALUES

ITEM	THREAD	TORQUE, IN-LBS
Circuit Breaker Mounting Bolts	.250-20	144
Circuit Breaker Cover Screws	.164-32	23
Mounting Block Mounting Stud	.375-16	144
Front Connect Cable Terminal	.312-24	81
Rear Connect Stud Nuts	.500-13	250
Trip Unit Mounting Screws	.375-15	144
Motor Operator Mounting Bolts	.250-20	144
Motor Operator Cover Screws	.164-32	23

## NET WEIGHTS

DESCRIPTION	NET WEIGHT, LBS. (KG)
AQB-A253 Frame	18.31 (8.3)
AQB-L253 Frame	18.96 (8.6)
Single AQB-A253 Breaker with Rating Plug	21.97 (10.0)
Single AQB-L253 Breaker with Rating Plug	21.97 (10.0)
Trip Units	2.82 (1.3)
Rating Plug	0.03 (0.01)

**Outline Dimensions  
AOB-A253, AOB-L253  
and NQB-A253 Breakers —  
Dimensions in Inches**

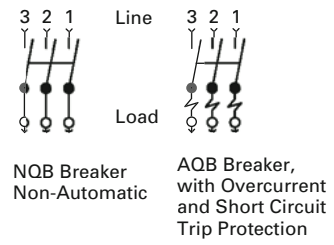
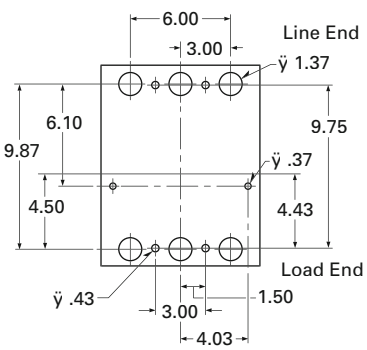
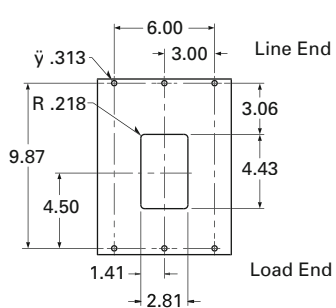
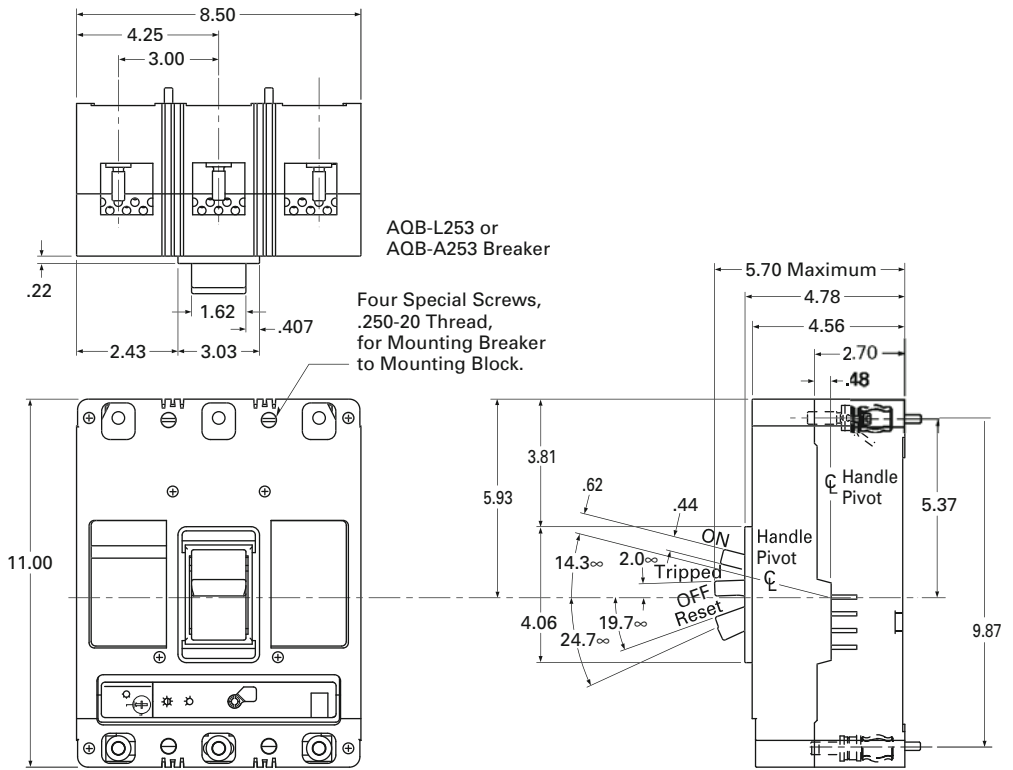

Minimum Front Panel Cutout

Drilling Plan for Terminal Mounting Block

Typical Wiring Diagram

Scale .375 = 1.00

# Types AQB-A253, AQB-L253 and NQB-A253

## Outline Dimensions AQB-A253, AQB-L253 and NQB-A253 Breakers — Dimensions in Inches

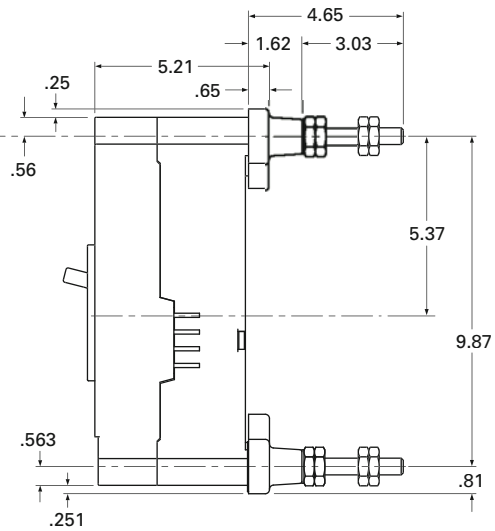
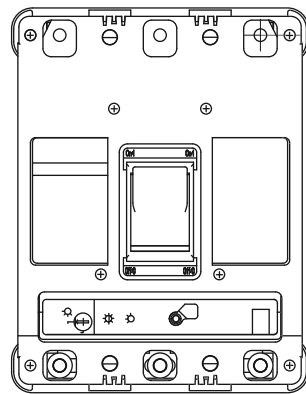
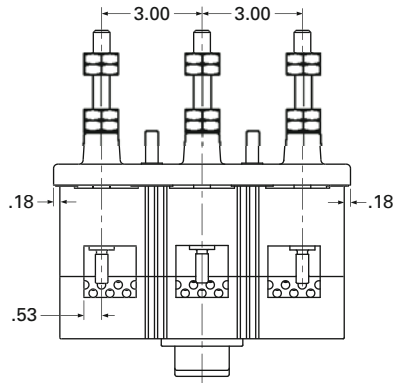

Reverse Position  
of Lock to Prevent  
Breaker from Opening

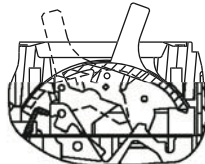

Cross Section

**Circuit Breaker Handle Locking Device  
(Not Supplied with Breaker)**

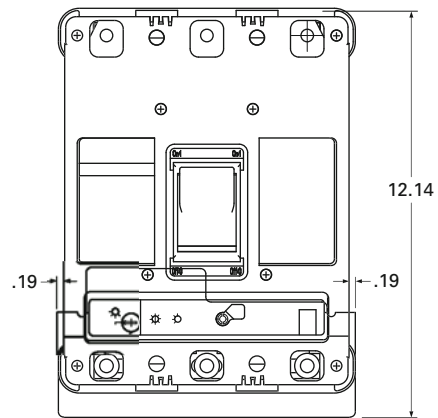

**Closeout Plate Location**

Scale: 1.00

**Time-Current Curve for  
AOB-A253 and AOB-L253  
Equipped with LES Digitrip  
RMS 310 Trip Units**

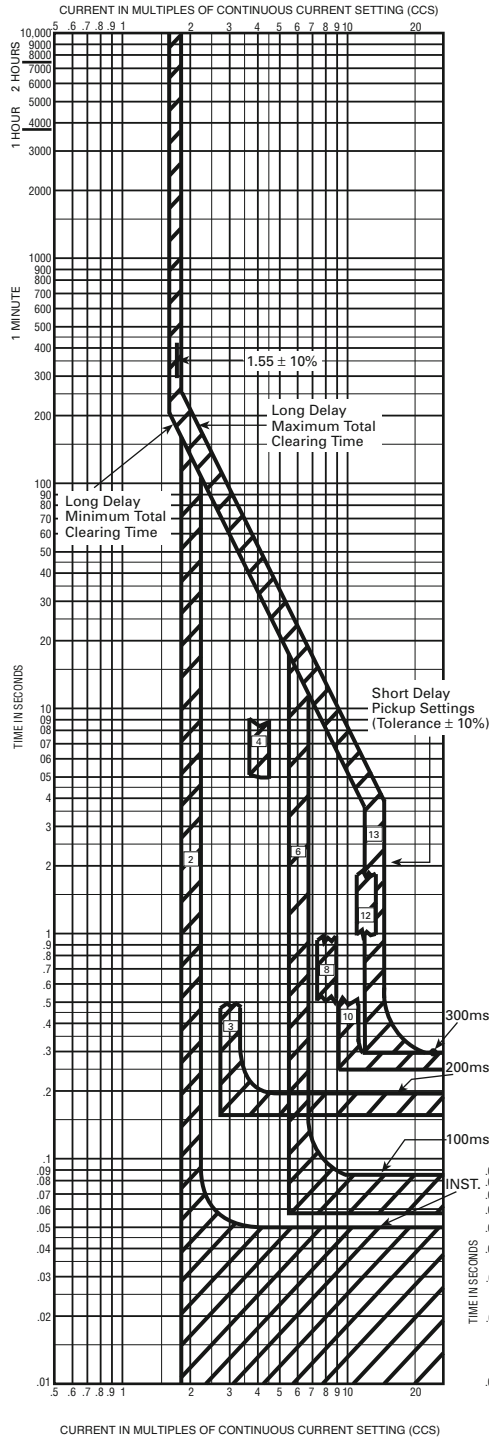

**Circuit Breaker Time/Current Curves (Phase Current)**

Types AOB-A253 and AOB-L253  
Equipped With LES Digitrip RMS 310 Trip Units

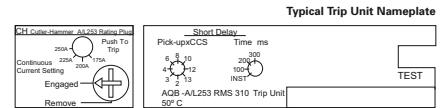

**Available Rating Plugs**

Continuous Current Setting (CCS)	Type	Rating Plug Catalog Number	Short Delay Pickup Range Amperes
100, 125, 150, 160	Adjustable	6603C02G52	200-2080
175, 200, 225, 250	Adjustable	6603C02G51	350-3250

Breaker Type	Voltage Rating	500 VAC	
		Frequency	Current
A253	Interrupting	60 Hz	400 Hz
L253	Current	30 kA	10 kA
		100 kA	-

- Notes**
- Curve accuracy applies from -20°C to +55°C ambient. For possible continuous ampere derating for ambient above 50°C, refer to Cutler-Hammer.
  - For high fault current level a fixed instantaneous override is provided at 7500A. (Tolerance ±20%).
  - The end of the curve is determined by the interrupting rating of the circuit breaker.
  - AOB-A/L253's are suitable for functional field testing with test kit Cat. Number STK2.
  - Calibration response in short delay pickup range is same for 1, 2 or 3 poles in series.
  - There are memory effects that can act to shorten the long delay. The memory effects come into play if a current above the long delay pickup value exists for a time and then is cleared by the tripping of a downstream device or the circuit breaker itself. A subsequent overload will cause the circuit breaker to trip in shorter time than normal. The amount of time delay reduction is inverse to the amount of time that has elapsed since the previous overload. Approximately five minutes are required between overloads to completely reset the memory.

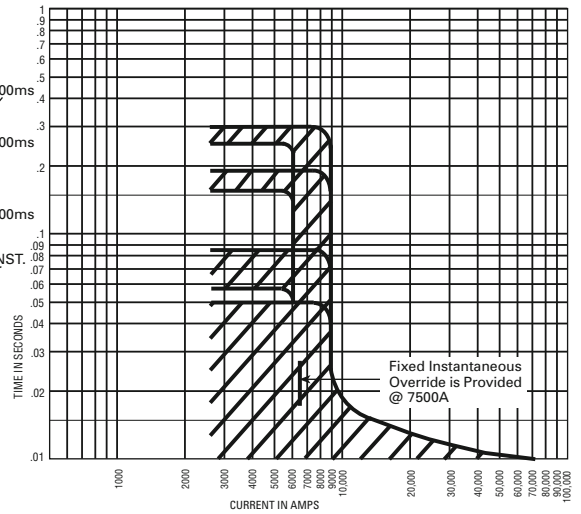

**CURVE NO. SC-7238-99**

# Types AQB-L400, AQB-LL400

## Circuit Breakers for Naval Shipboard Use — Types AQB-L400, AQB-LL400 Breakers

Types AQB-L400QF, AQB-L400QM: 150,000 Amperes I.C. and AQB-LL400QS: 100,000 Amperes I.C. 250 – 400 Amperes; 500 Volts ac, 60 Hz.



*AQB-LL400QS Breaker*



*Motor Operator Mounted on  
Circuit Breaker*

AQB-L400QF, AQB-L400QM and AQB-LL400QS current limiting circuit breakers are designed for installation in switchboards for protection of generators and feeders and branch circuits with available fault currents of 150,000 amperes maximum.

### Description

The Navy Type AQB-L400QF, AQB-L400QM, and AQB-LL400QS molded case circuit breakers are 500 Vac maximum rated devices with electronic trip units rated at 400 amperes maximum continuous current at 60 Hz. The circuit breakers are assembled as 3-pole units which may be used as 2- or 3-pole devices.

The circuit breakers are designed to MIL-C-17361 and meet the requirements of Class HI-shock, MIL-S-901. The circuit breaker electronic trip unit has adjustable short delay time and pickup trip settings which can be readily changed at the operator level to meet the shipboard system trip requirements. Four interchangeable rating-plugs are available to select the continuous current rating of 250, 300, 350 or 400 amperes. Also provided is a non-adjustable inverse time delay tripping action for overload conditions, and instantaneous tripping for protection against short circuit conditions that exceed the preset short delay pickup setting. In open air at 50°C, the circuit breaker will carry continuously a current equal to the ampere rating of the installed rating plug. The calibration of the trip unit is insensitive to ambient temperatures over a range of -20°C to +70°C.

### Operation

The AQB-L400QF, AQB-L400QM, and AQB-LL400QS current limiting circuit breakers (without the need for current limiting fuses) are designed to provide circuit protection for low voltage distribution systems. The circuit breakers will disconnect a load from an electrical supply when the handle is operated, when an overcurrent or short circuit condition develops, or when the push-to-trip button in the trip unit is manually pressed. A complete breaker consists of a breaker, rating plug plus mounting blocks and is available with numerous attachments such as electrical operator, shunt trip, undervoltage release and auxiliary switches to perform varied auxiliary functions.

The circuit breaker has a spring-loaded independent over-toggle operating mechanism that provides a quick-make quick-break trip-free operation.

The operating mechanism also provides the electro-mechanical means to open the contacts when trip conditions occur. When current is flowing through the contacts of the circuit breaker, the positions of the lower contact arms and the moving contact arms induce opposing magnetic fields. The resulting opposing forces along the magnetic flux lines cause rapid contact blow-apart under high current fault conditions. The AQB-L400QF and AQB-L400QM circuit breakers have slot motors for each moving contact arm to intensify the magnetic field and further increase the blow-apart effect.

### Specifications

- AQB-L400QF, AQB-L400QM and AQB-LL400QS Current Limiting Navy Circuit Breakers.
- 250 – 400 Amperes, 500 Volts ac, 60 Hz.

#### Note:

Call Eaton for 400 Hz.

- 3-Pole Only, 50°C Ambient.

### Continuous Current Rating

- 250, 300, 350 and 400 Amperes.

### Current Interruption Ratings

- AQB-L400QF — 150,000 Amperes
- AQB-L400QM — 150,000 Amperes
- AQB-LL400QS — 100,000 Amperes

### Protective Functions

- Long Delay Pickup (Minimum Thermal Trip) (Fixed) 131% to 156% (All Ratings)

### Protective Functions

Short Delay Pickup (Adjustable)

- AQB-L400QF — 650 – 1500 Amperes
- AQB-L400QM — 1700 – 3200 Amperes
- AQB-LL400QS — 3600 – 5800 Amperes

Short Delay Time (Adjustable)

- MIN, 1, 2, 3, MAX. (5 Bands)
- See Trip Curves or MIL-Spec

### Instantaneous Pickup (Fixed)

- AQB-L400QF — 1850 Amperes
- AQB-L400QM — 3280 Amperes
- AQB-LL400QS — 6300 Amperes

This enables these circuit breakers to have an interrupting rating of 150 kA compared with the AQB-LL400QS rating of 100 kA.

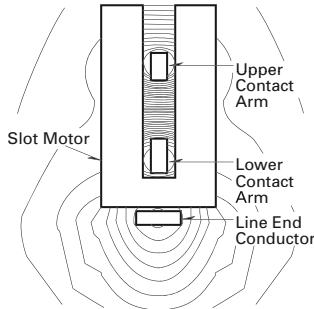

**MAGNETIC FIELD WITH SLOT MOTOR**

A push-to-trip button is provided to manually trip the circuit breaker. When the button is pressed, a plunger rotates the latch lever causing the circuit breaker to trip.

All trip units are built into the circuit breaker frames and use electronic sensing elements. The Types AQB-L400QF, AQB-L400QM, and AQB-LL400QS Seltronic trip units provide protection functions. All trip units are supplied electrically from current sensors mounted on the main conductors in the circuit breaker base. A field-installed rating plug determines the continuous ampere rating of the trip unit. An electrical interlock causes the circuit breaker to trip at current levels of 75% or more if the rating plug is not installed. Under fault conditions, the trip unit will initiate a trip signal and energize the flux shunt trip. When the flux shunt trip operates, the plunger extends and rotates the trip lever. As the trip lever rotates, the latch lever rotates which unlatches the trigger and the circuit breaker trips.

**Overload Trip** — The trip unit initiates an ultimate trip of the circuit breaker within one hour for an overload of 131% to 156%, and in less time for higher overloads.

**Short Delay Trip** — For short circuit conditions that exceed the short delay pickup setting but not the instantaneous (override) pickup, the trip unit initiates a trip after the selected short delay time setting.

**Instantaneous Trip** — For short circuit conditions that exceed the instantaneous (override) pickup value, but not the current-limiting threshold, the trip unit initiates a trip with no intentional delay.

**AQB-L400 AND AQB-LL400 CIRCUIT BREAKER PRODUCT SELECTION** ①

BREAKER TYPE	STYLE NUMBER	NATIONAL STOCK NUMBER
<b>Circuit Breaker, Navy Type (Supplied with male plug-in adapters installed for or rear connection) ②</b>		
AQB-LL400QS	1230C83G01	5925-01-356-4514
AQB-L400QF	1230C83G02	5925-01-440-3934
AQB-L400QM	1230C83G03	5925-01-360-5605
AQB-LL400	1230C83G04	5925-01-512-5100
AQB-LL400QS Mag Only	1230C83G05	—
AQB-L400QM Mag Only	1230C83G06	—
<b>Rating Plug</b>		
250Q, 250 Amperes	1230C84G01	5925-01-356-8864
300Q, 300 Amperes	1230C84G02	5925-01-356-5973
350Q, 350 Amperes	1230C84G03	5925-01-356-5974
400Q, 400 Amperes	1230C84G04	5925-01-356-5975

① For list prices, see Price and Availability Digest (PAD).

② Does not include rating plug.

**Motor Operator**

The motor operator is designed to remotely switch a circuit breaker to its ON, OFF and relatch positions. The relatch function will occur automatically after a circuit breaker trip operation. The motor operator is self-contained and assembled in its own mounting frame which mounts on the front of the circuit breaker. When the ON or OFF remote control button is pressed,

current flows to the electric motor which turns a ball bearing and screw assembly driving the carrier and roller assembly. Two rollers fit over the circuit breaker handle and move with the handle through its range of movement. Limit switches control the travel of the carrier assembly. A terminal block is provided in the mounting frame for control connections.

Bell alarm 752B515G01 is included.

**MOTOR OPERATOR PRODUCT SELECTION**

TYPE	STYLE NUMBER	NATIONAL STOCK NUMBER
Motor Operator 115 Vac, 60 Hz ③	1234C53G01	5925-01-348-9823

③ If 450 Vac required, then customer should supply own minimum 1 kVA step-down transformer per motor operator.



# Types AQB-L400, AQB-LL400



**CIRCUIT BREAKERS, NAVY TYPE, AQB-L400QF, AQB-L400QM, AND AQB-LL400QS (TOP) AND MOTOR OPERATOR (BOTTOM)**

## MOUNTING BLOCK

TYPE	STYLE NUMBER	NATIONAL STOCK NUMBER
Plug-in Mounting Block, Rear Connected, Complete (Required One Per Load or Line End)	1230C81G01	5975-01-457-5094
Mounting Block, Molded Base Only (For Mounting a Front Connected Circuit Breaker, or as a Replacement Part)	1230C81G05	—
Male Slip Connectors (Replacement Part, Three Per Kit)	1230C81G04	—
Front Connected Terminal (Required Three Per Line or Load End)	504C497G01	—

## AUXILIARY SWITCHES

TYPE	STYLE NUMBER	NATIONAL STOCK NUMBER
1a/1b 115-450 Vac	1220C86G01	5930-01-358-5608
2a/2b 115-450 Vac	1220C86G02	5930-01-356-5780
1a/1b 120 Vdc	1220C86G05	—
2a/2b 120 Vdc	1220C86G06	—
1a/1b 115-450 Vac and 1a/1b 120 Vdc Combination	1220C86G07	—

## SHUNT TRIP

TYPE	STYLE NUMBER	NATIONAL STOCK NUMBER
<b>Shunt Trip (Left-Pole only) (Includes Build-in Cutoff Switch)</b>		
115 Vac/28 to 120 Vdc	1220C86G03	6625-01-356-5176
450 Vac Only	1220C86G04	5925-01-368-1501
<b>Combination Shunt Trip and 1a/1b Auxiliary Switch (Left-Pole Only)</b>		
115 Vac/28-120 Vdc Shunt Trip and 115-450 Vac Auxiliary Switch	1220C86G08	5925-01-358-4082
115 Vac/28-120 Vdc Shunt Trip and 120 Vdc Auxiliary Switch	1220C86G09	5925-01-445-7323
450 Vac Shunt Trip and 115-450 Vac Auxiliary Switch	1220C86G10	—
450 Vac Shunt Trip and 120 Vdc Auxiliary Switch	1220C86G11	—

## “SHORE POWER” MOTOR OPERATOR (DDG-51 CLASS)

TYPE	STYLE NUMBER	NATIONAL STOCK NUMBER
Motor Operator 115 Vac (Works with UVR)	1241C42G01	5925-01-407-3083

## “SHORE POWER” BREAKER (DDG-51 CLASS)

TYPE	STYLE NUMBER	NATIONAL STOCK NUMBER
LL400QS with UVR and 2A2B	1241C34G02	5925-01-442-3696

## BREAKER WITH UNDERVOLTAGE RELEASE

(Only Left-Pole) UVR and Circuit Breaker must be ordered as an integral unit.

TYPE	STYLE NUMBER	NATIONAL STOCK NUMBER
<b>Undervoltage Release Mechanism (LH) Factory Installed</b>		
AQB-L400QF with 115 Vac	<b>1230C83G15</b>	—
AQB-L400QF with 450 Vac ①	<b>1230C83G16</b>	—
AQB-L400QF with 120 Vdc	<b>1230C83G17</b>	—
AQB-L400QF with 250 Vdc	<b>1230C83G18</b>	5925-01-521-6181
AQB-L400QM with 115 Vac	<b>1230C83G19</b>	—
AQB-L400QM with 450 Vac ①	<b>1230C83G20</b>	—
AQB-L400QM with 120 Vdc	<b>1230C83G21</b>	—
AQB-L400QM with 250 Vdc	<b>1230C83G22</b>	—
AQB-LL400QS with 115 Vac	<b>1230C83G11</b>	5925-01-514-3469
AQB-LL400QS with 450 Vac ①	<b>1230C83G12</b>	5925-01-356-4518
AQB-LL400QS with 120 Vdc	<b>1230C83G13</b>	—
AQB-LL400QS with 250 Vdc	<b>1230C83G14</b>	—

① Using externally-mounted step-down transformer supplied. Not field mountable.

### Switchboard Mounting

Breaker frame includes mounting hardware. Stud projections are mounted on the rear of the breaker for plugging into female slip connectors of terminal mounting block assemblies.

### Handle Lock

(For shipboard maintenance use only) order style number 1720101.

### Trip Unit Test Port Plug

For extra plugs, order 5091A80H01.

### Fungus-Moisture-Resistance Treatments

(JAN-T-152; JAN-C-173; MIL-V-173)

If specified, contact Eaton. External parts are coated.

### Technical Manual

When required, order 1240C33H01.

### Master Drawing – 1375D92.

### Portable Test Kit

Can be used to functionally test the breaker for overload and short circuit, while breaker is mounted. When required, order catalog number STK2.

## Individual Reproduction

When required, reproduction of outline drawings and certification sheets can be ordered as follows.

ITEM	DESCRIPTION
1	Outline Drawing and Drilling Plan on Vellum
2	Certification Data on Vellum
3	Reproduction of Items 1 and 2

## NET WEIGHT

DESCRIPTION	NET WEIGHT
Circuit Breaker	30 lbs.
Motor Operator	22 lbs.
Mounting Block	10 lbs.
Front Connected Terminals (Set of Three)	1 lb.-10-1/4 ozs.
Portable Test Kit	12 lb.-14-1/4 ozs.
Rating Plug	2 ozs.
Shunt Trip	3 ozs.
Auxiliary Switch	2.5 ozs.

## Adapter Kit

Style Number 6590C82G01/  
National Stock Number 5925-01-452-3858

## LF400 Mtg. Block

6590C82G03

# Types AQB-L400, AQB-LL400

## Eaton Adapter Kit and Navy Type AQB-L400 Molded Case Circuit Breaker Combination in AQB-LF400

The Navy Type AQB-L400 or AQB-LL400 circuit breakers when supplied with a factory installed Eaton AQB-L400 Adapter Kit, can be installed directly into Navy Type AQB-LF400 applications. This combination of an AQB-L400/LL400 circuit breaker and the Eaton Adapter Kit provides a direct one-to-one current limiting type L400 circuit breaker replacement for an already installed fused type LF400 circuit breaker. Existing AQB-L400/LL400 circuit breakers in the field (manufactured prior to August, 1992) may need a factory modification to accept the Adapter Kit. Contact Eaton for details, if there are any questions.

An Eaton AQB-L400 Adapter Kit provides the means for converting the normally male configured primary connections of an AQB-L400/LL400 current limiting circuit breaker to female configured primary connections, normally associated with an AQB-LF400 circuit breaker. A close out plate, attached directly to the front of the AQB-L400 circuit breaker with four mounting screws, provides the deadfront cover required to complete the conversion. This close out plate blanks out the hole in the switchboard door or cover, through which the LF400 fuse pack protruded.

The adapter kit itself is comprised of line and load side adapter blocks, six female spring loaded primary connection adapters, a close out plate, and four mounting screws.

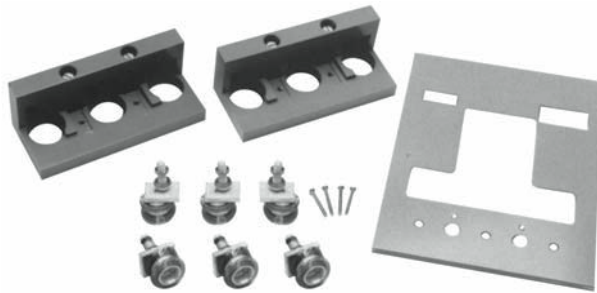

*Eaton Adapter Kit Parts Before Installation*



*Navy Type AQB-L400 Molded Case Circuit Breaker with Adapter Kit Factory Installed*



*Navy Type AQB-L400 Circuit Breaker and Adapter Kit Combination Plugged into AQB-LF400 Mounting Blocks*

### Net Weight

34 Lbs. (15 kg) (Breaker plus adapter).

### L400/LL400 BREAKER WITH ADAPTER KIT (CALL EATON FOR OTHER CONFIGURATIONS)

BREAKER STYLE NUMBER	CONSISTS OF BREAKER FRAME	PLUS PLUG	PLUS ATTACHMENTS	PLUS ADAPTER KIT
1241C54G01	LL400QS	400Q	115 Vac/28 Vdc ST and 115/450 Vac Aux. SW	6590C82G01
1241C54G02	L400QF	250Q	None	6590C82G01
1241C54G03	LL400QS	400Q	450 Vac ST and 1A/1B Aux. SW	6590C82G01
1241C54G04	LL400QS	400Q	1A/1B Aux. SW	6590C82G01
1241C54G05	L400QM	300Q	450 Vac ST and 1A/1B Aux. SW	6590C82G01
1241C54G06	LL400QS	400Q	None	6590C82G01
1241C54G07	LL400QS	300Q	450 Vac ST and 1A/1B Aux. SW	6590C82G01
1241C54G08	L400QM	350Q	450 Vac ST and 1A/1B Aux. SW	6590C82G01
1241C54G09	LL400QS	350Q	None	6590C82G01
1241C54G10	L400QM	400Q	None	6590C82G01
1241C54G11	LL400QS	400Q	450 Vac UVR & 2A/2B Aux. SW	6590C82G01
1241C54G12	L400QM	350Q	115 Vac ST	6590C82G01
1241C54G13	L400QM	300Q	115 Vac/28 Vdc ST and 115/450 Vac Aux. SW (1220C86G08)	6590C82G01
1241C54G14	L400QM	400Q	1A/1B Aux. SW	6590C82G01
1241C54G15	LL400QS	400Q	115 Vac/28 Vdc Shunt Trip (1220C86G08)	6590C82G01
1241C54G16	LL400QS	350Q	450 Vac UVR and 2A/2B Aux. SW	6590C82G01

**Outline Dimensions  
AQB-L400, AQB-LL400 —  
Dimensions in Inches**

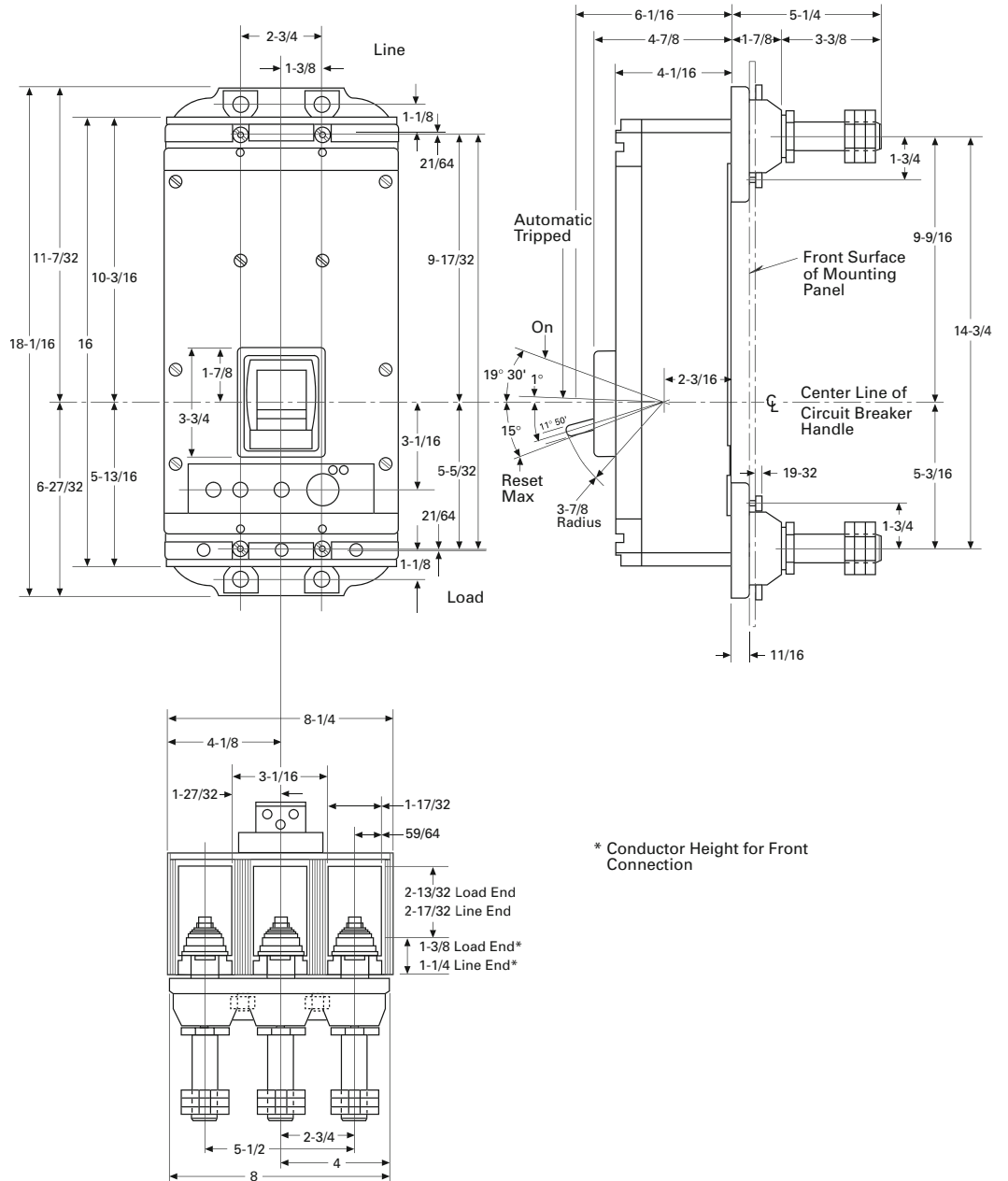

# Types AQB-L400, AQB-LL400

## Outline Dimensions AQB-L400, AQB-LL400 with Motor Operator — Dimensions in Inches

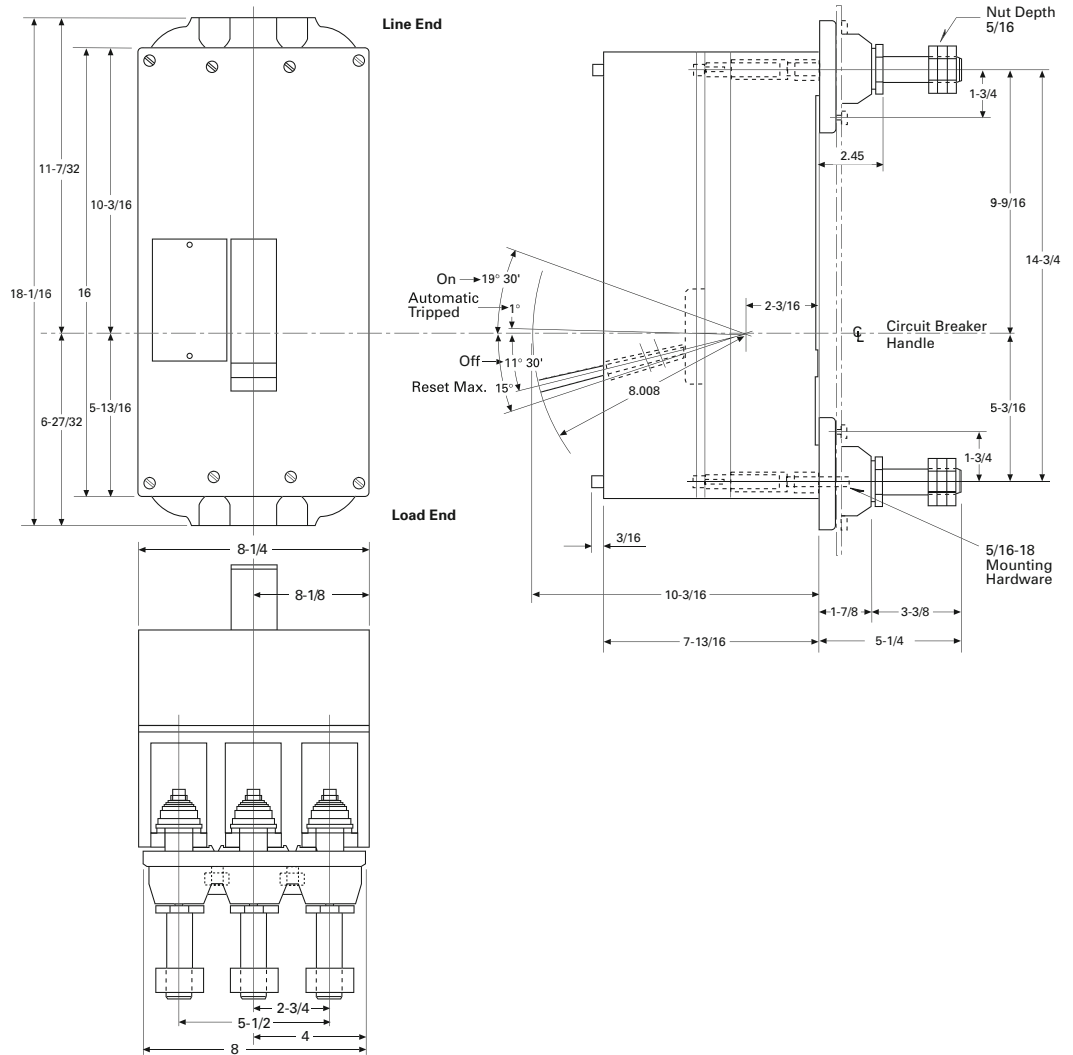

## Wiring Diagrams

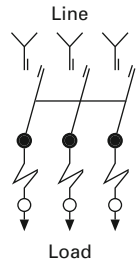

AQB Breaker With Overcurrent  
and Short Circuit Trip Protection

For 2-Pole Breakers  
Use Two Outside Poles

## Front Sheet Template — Dimensions in Inches

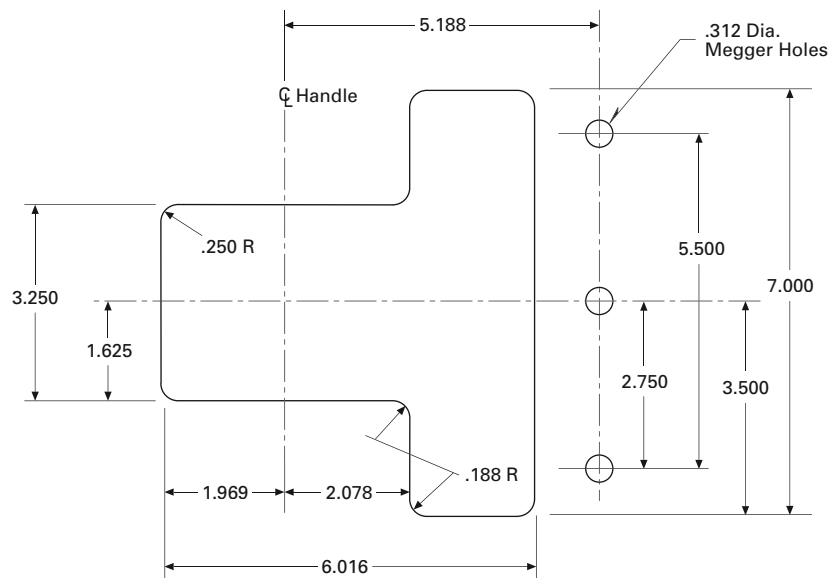

## Drilling Plan for Mounting Panel — Dimensions in Inches

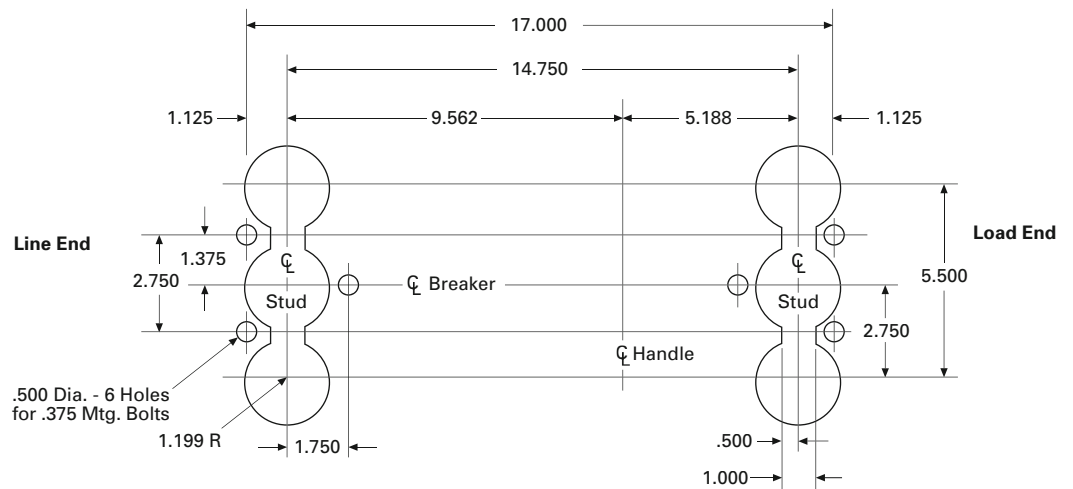

# Types AQB-L400, AQB-LL400

## Characteristic Time-Current Curves

Navy Type AQB-L400QF  
Circuit Breaker

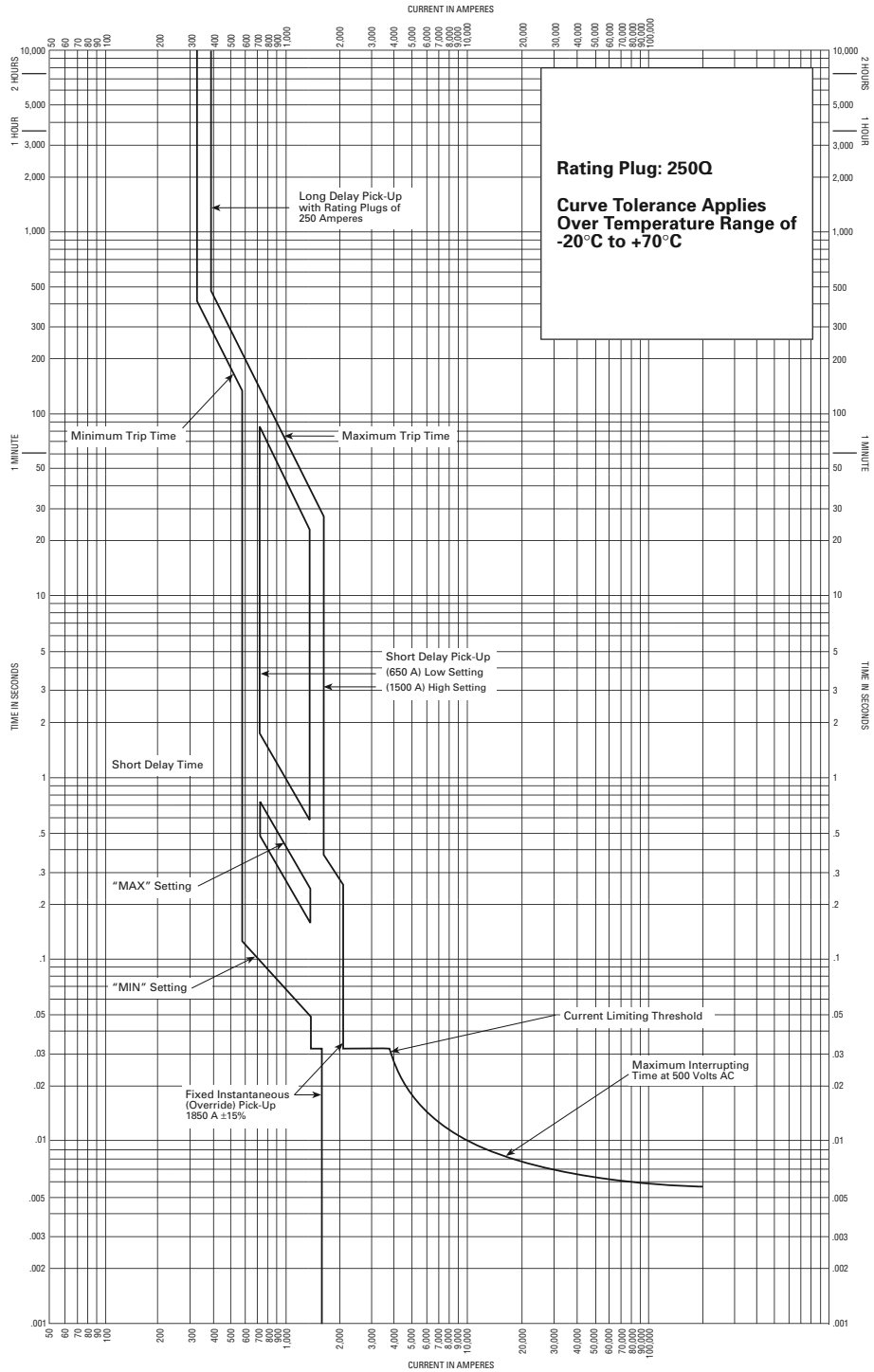

**TIME-CURRENT CURVES FOR AQB-L400QF CIRCUIT BREAKER WITH 250 AMPERE RATING PLUG**

# Characteristic Time-Current Curves

Navy Type AQB-L400QF  
Circuit Breaker

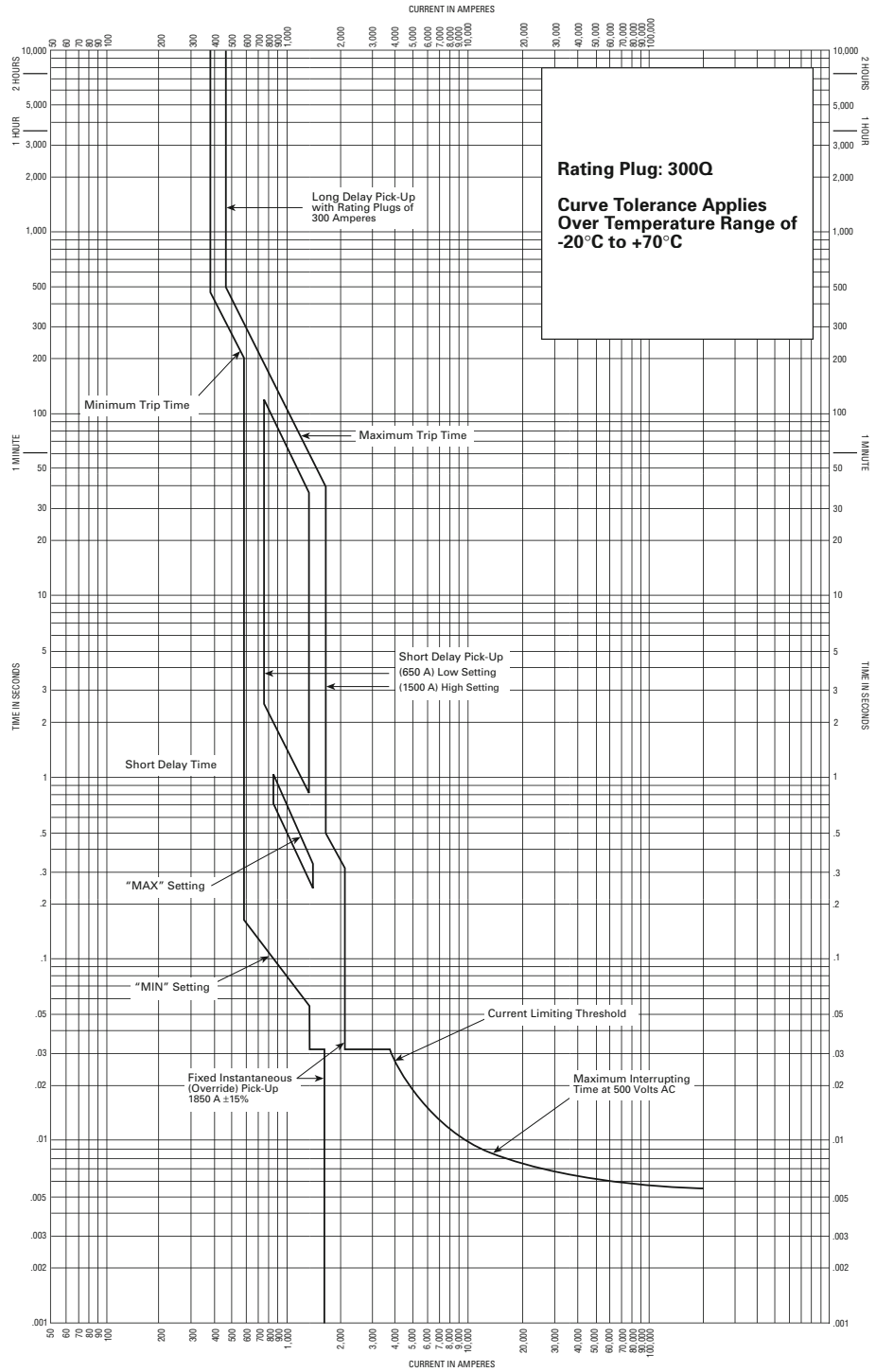

**TIME-CURRENT CURVES FOR AQB-L400QF CIRCUIT BREAKER WITH 300 AMPERE RATING PLUG**



# Types AQB-L400, AQB-LL400

## Characteristic Time-Current Curves

Navy Type AQB-L400QF  
Circuit Breaker

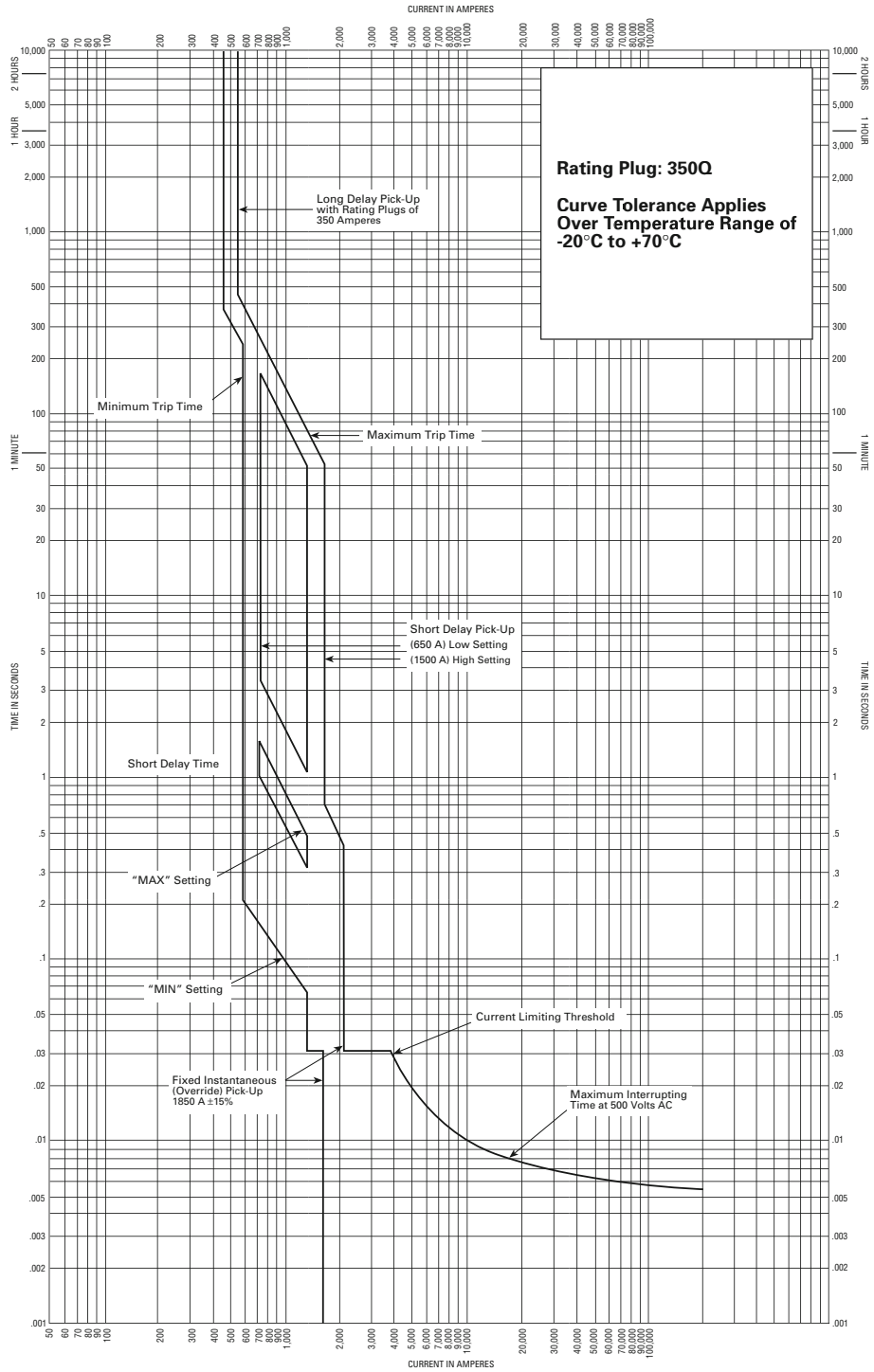

**TIME-CURRENT CURVES FOR AQB-L400QF CIRCUIT BREAKER WITH 350 AMPERE RATING PLUG**

# Characteristic Time-Current Curves

Navy Type AQB-L400QF  
Circuit Breaker

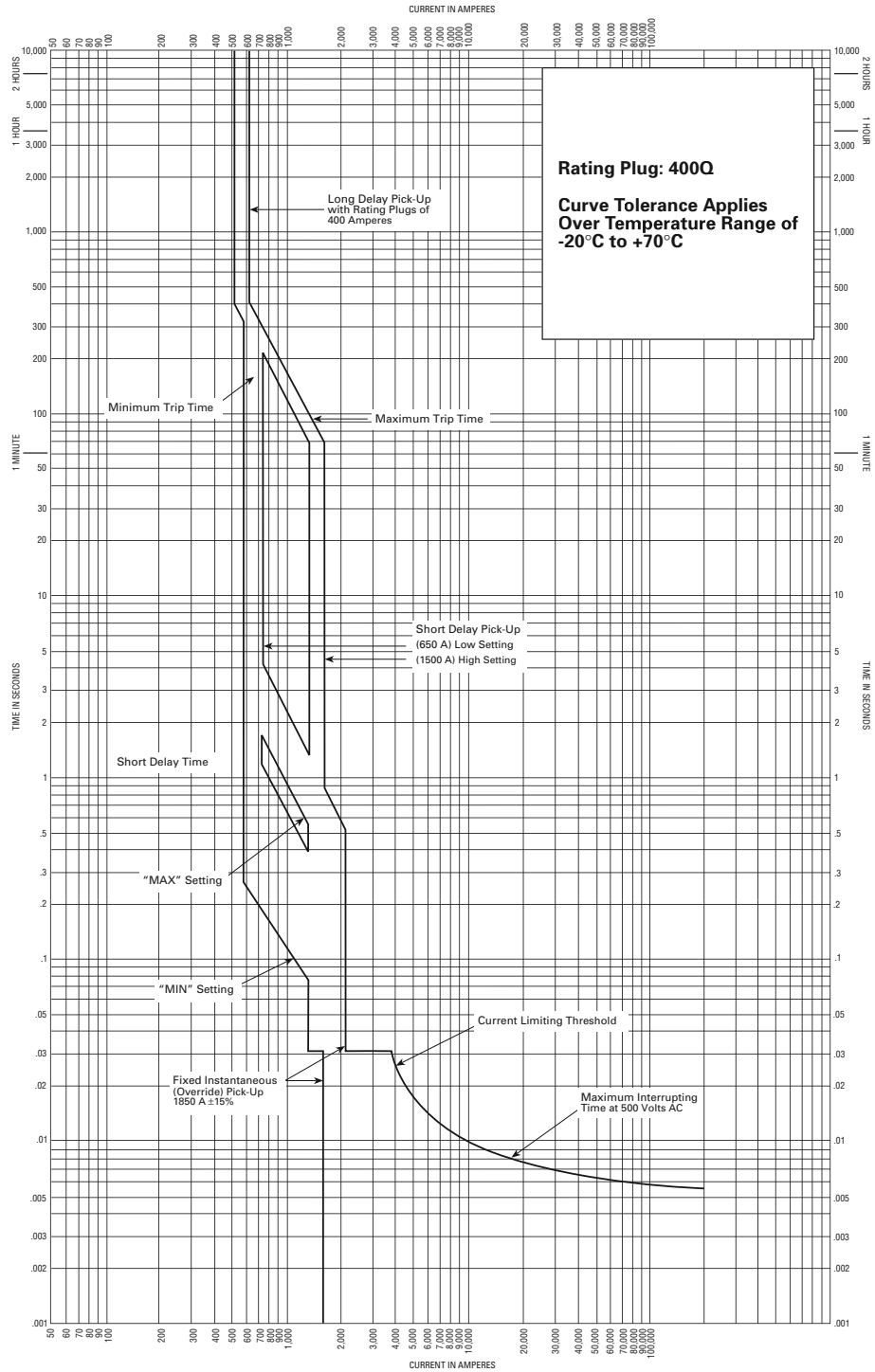

**TIME-CURRENT CURVES FOR AQB-L400QF CIRCUIT BREAKER WITH 400 AMPERE RATING PLUG**

# Types AQB-L400, AQB-LL400

## Characteristic Time-Current Curves

Navy Type AQB-L400QM  
Circuit Breaker

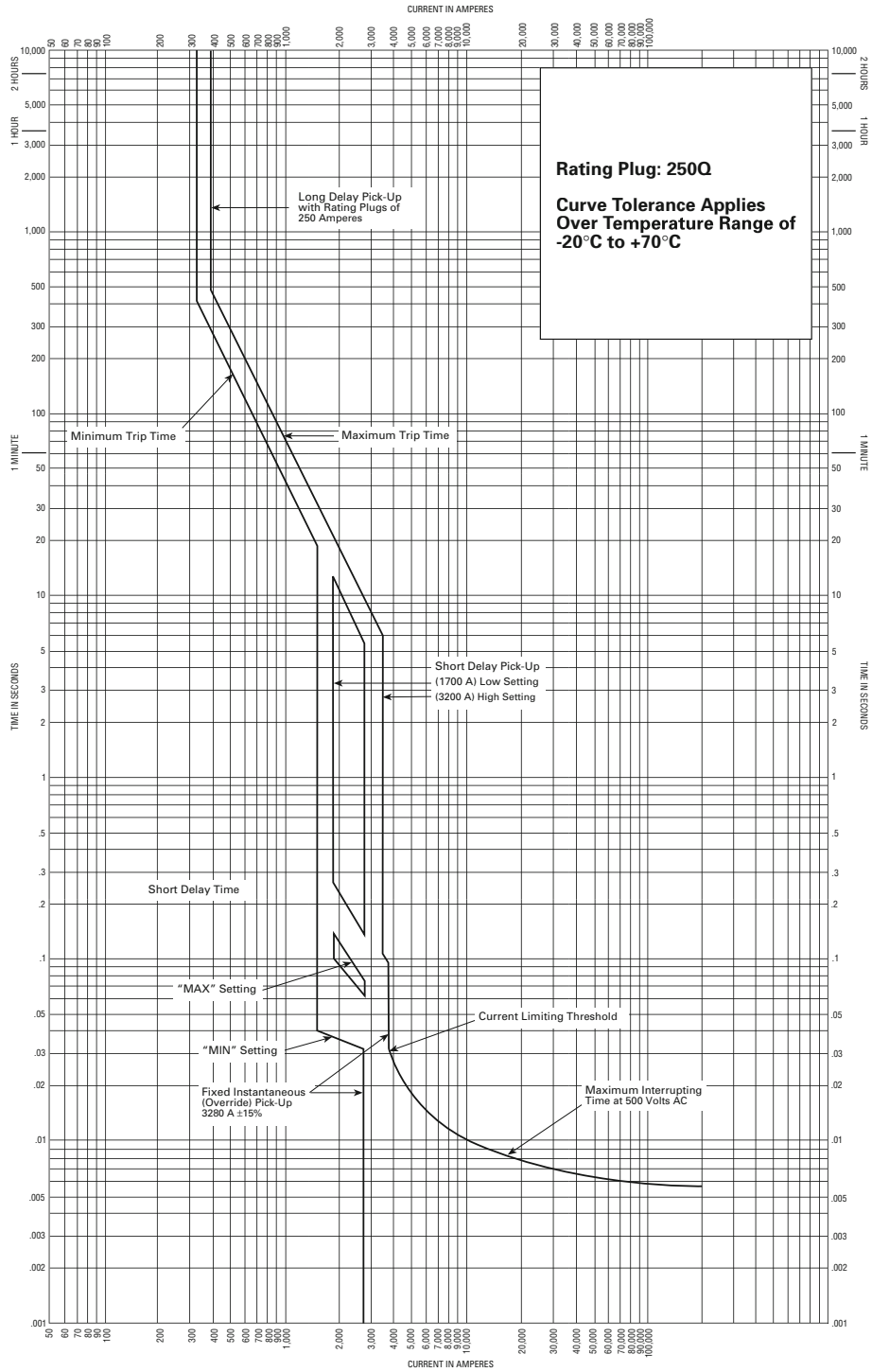

**TIME-CURRENT CURVES FOR AQB-L400QM CIRCUIT BREAKER WITH 250 AMPERE RATING PLUG**

# Characteristic Time-Current Curves

Navy Type AQB-L400QM  
Circuit Breaker

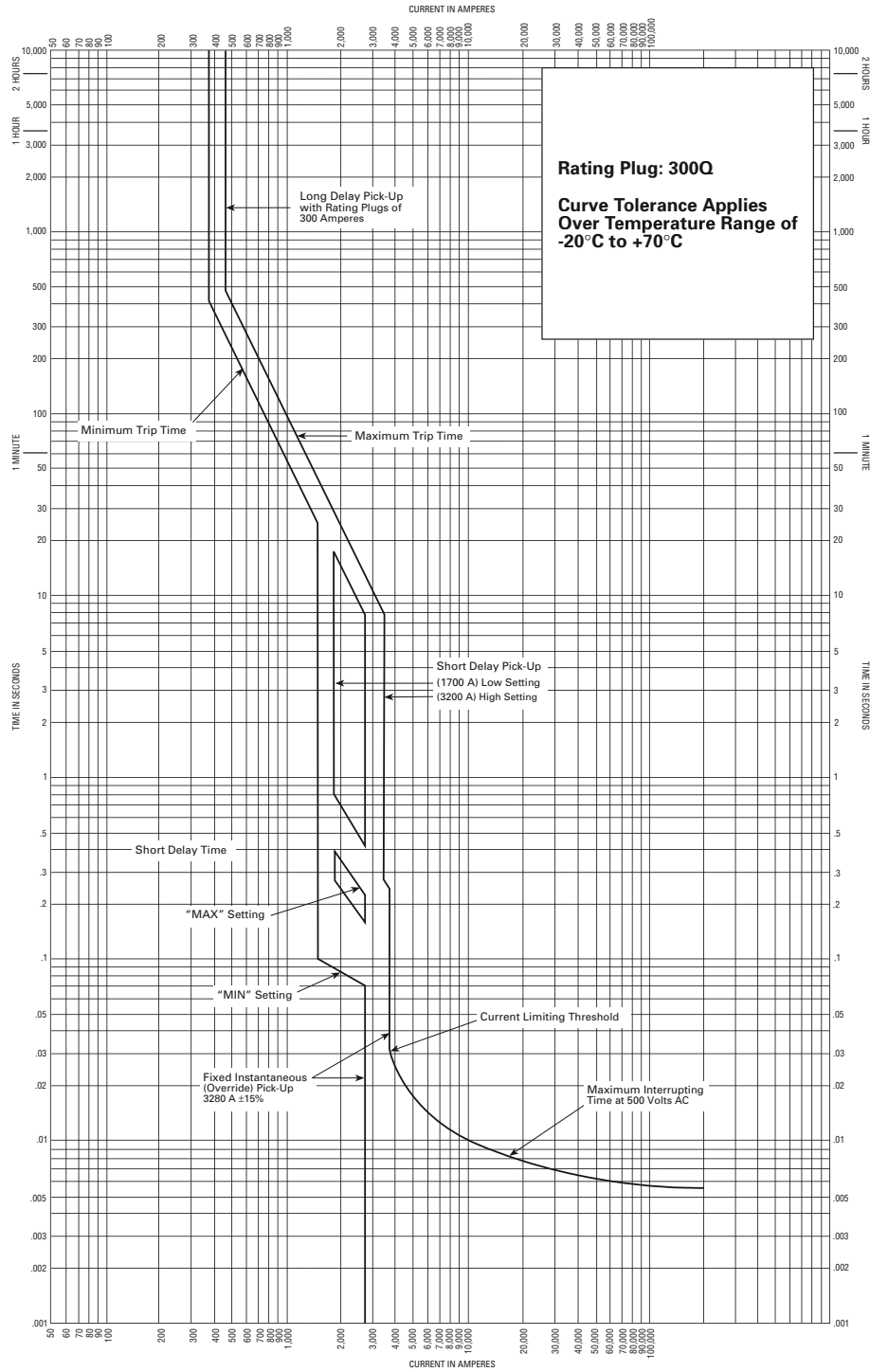

**TIME-CURRENT CURVES FOR AQB-L400QM CIRCUIT BREAKER WITH 300 AMPERE RATING PLUG**

# Types AQB-L400, AQB-LL400

## Characteristic Time-Current Curves

Navy Type AQB-L400QM  
Circuit Breaker

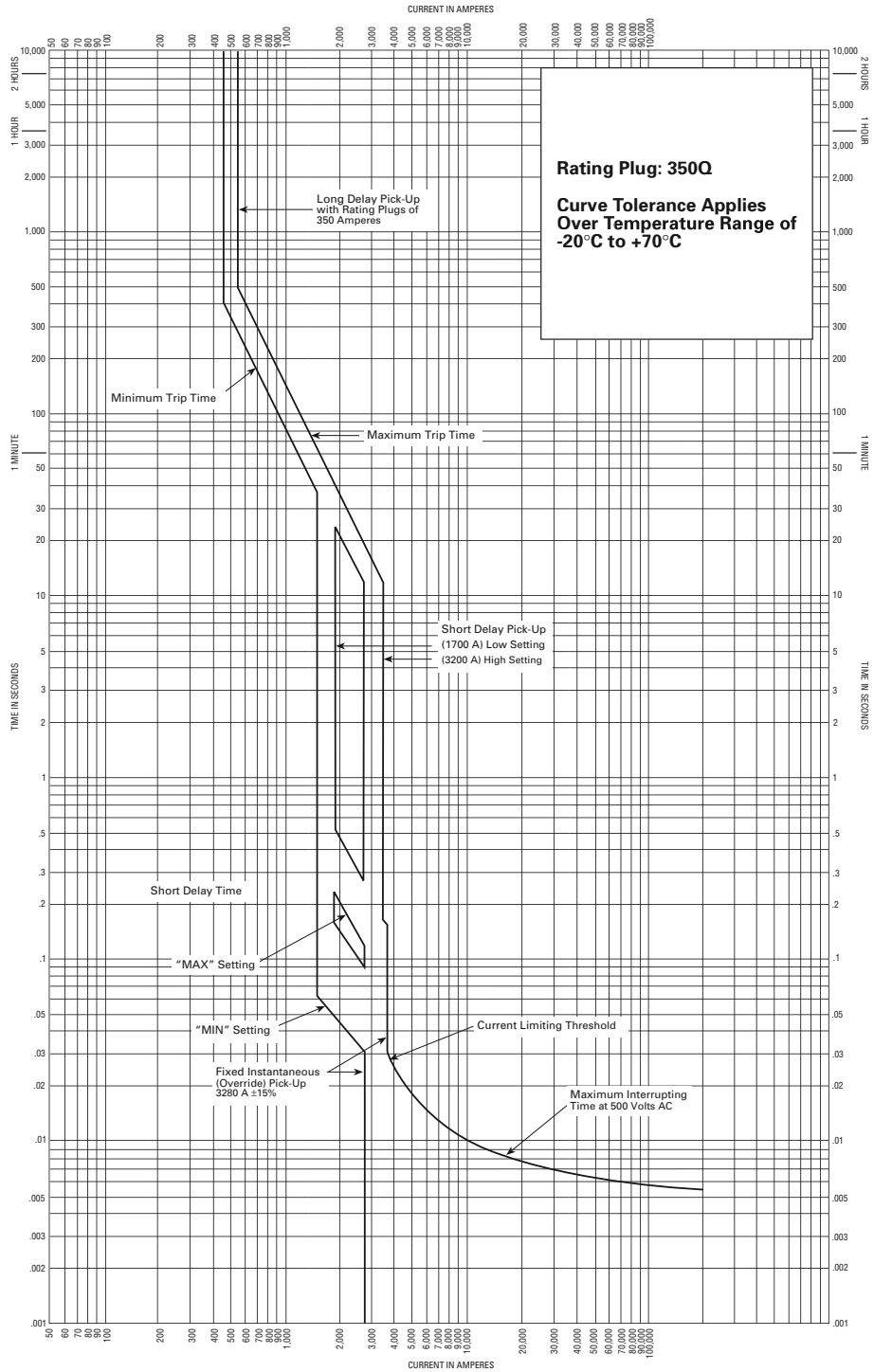

**TIME-CURRENT CURVES FOR AQB-L400QM CIRCUIT BREAKER WITH 350 AMPERE RATING PLUG**

# Characteristic Time-Current Curves

Navy Type AQB-L400QM  
Circuit Breaker

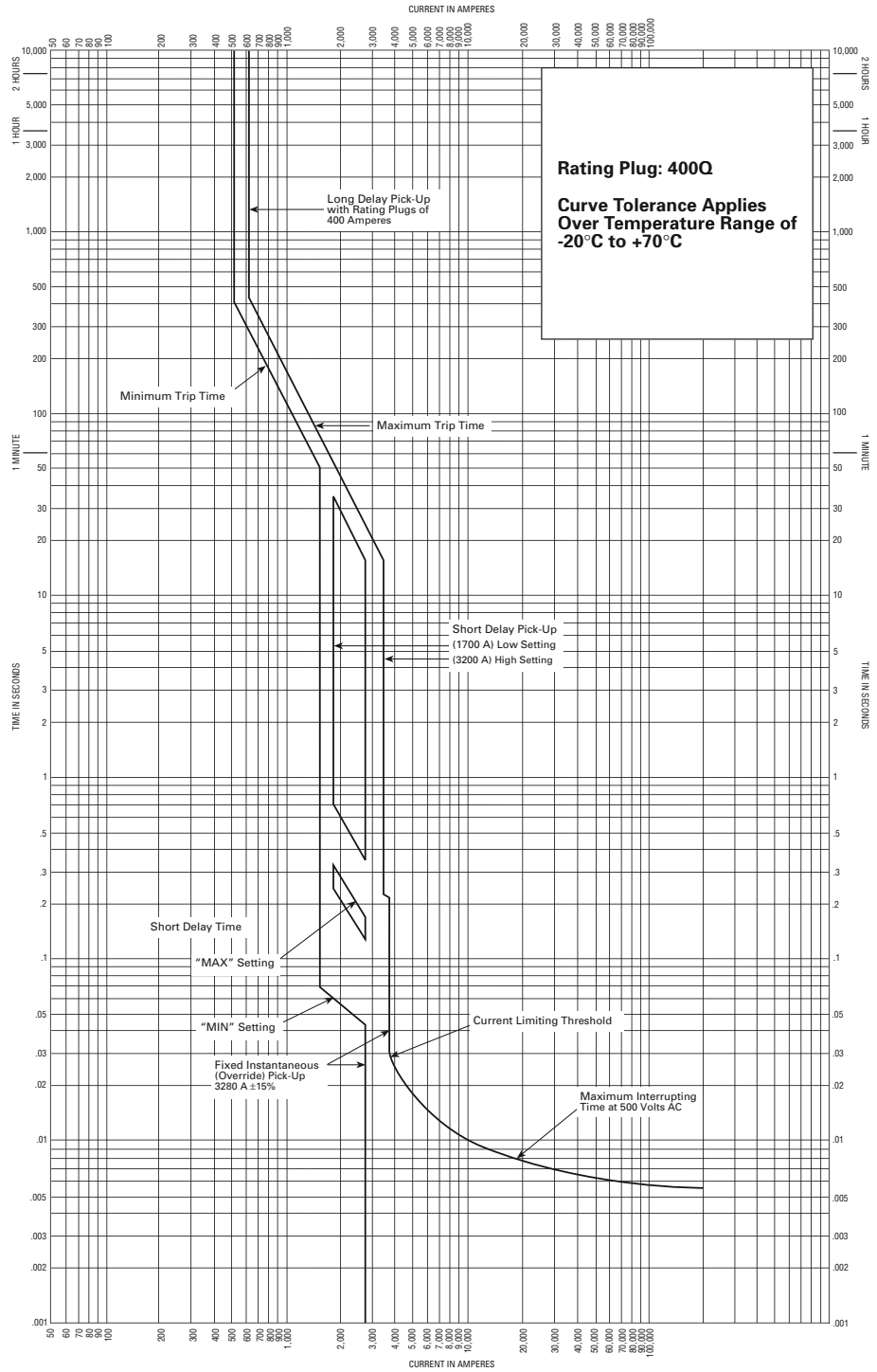

**TIME-CURRENT CURVES FOR AQB-L400QM CIRCUIT BREAKER WITH 400 AMPERE RATING PLUG**

# Types AQB-L400, AQB-LL400

## Characteristic Time-Current Curves

Navy Type AQB-LL400QS  
Circuit Breaker

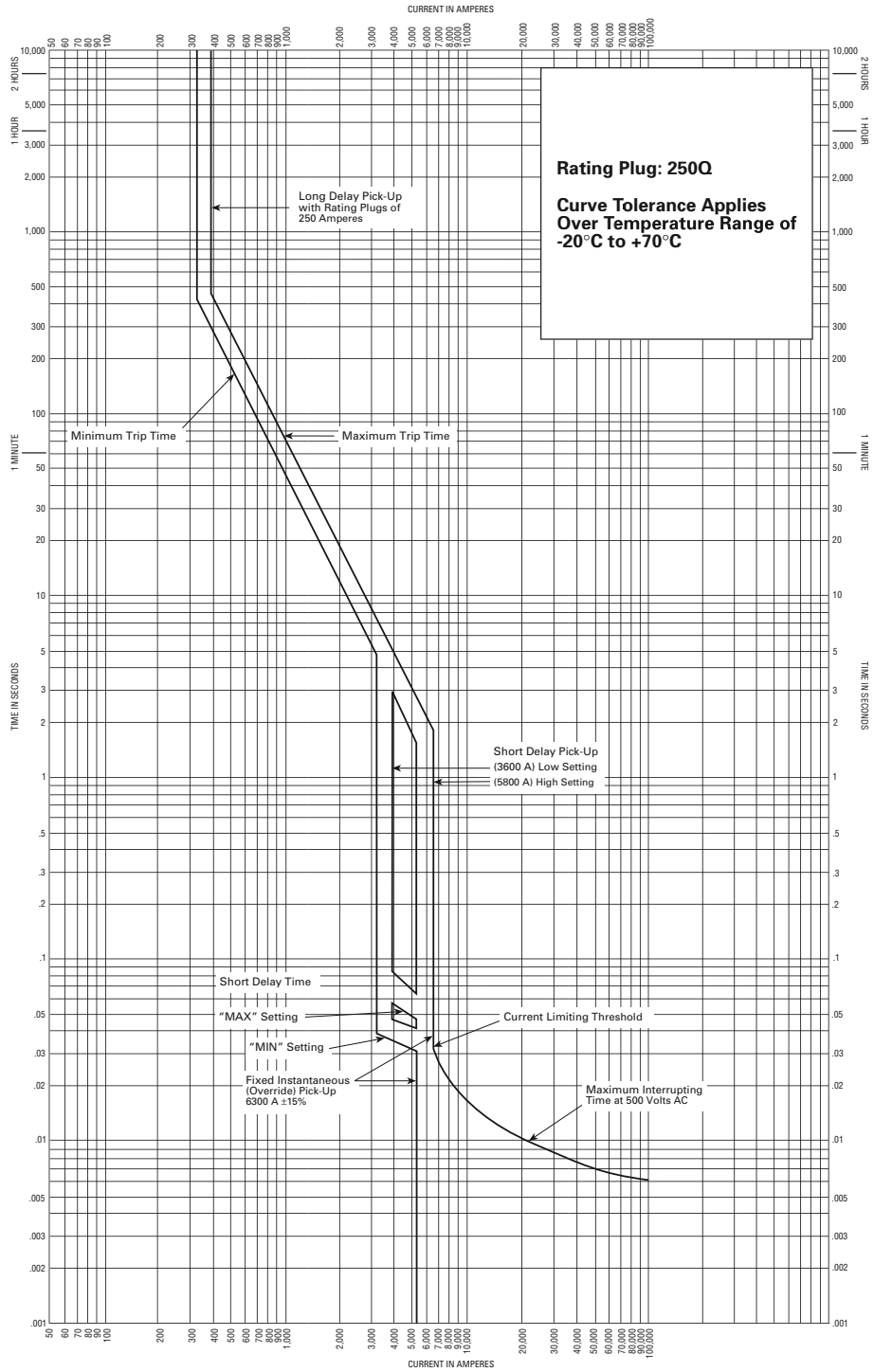

**TIME-CURRENT CURVES FOR AQB-LL400QS CIRCUIT BREAKER WITH 250 AMPERE RATING PLUG**

# Characteristic Time-Current Curves

Navy Type AQB-LL400QS  
Circuit Breaker

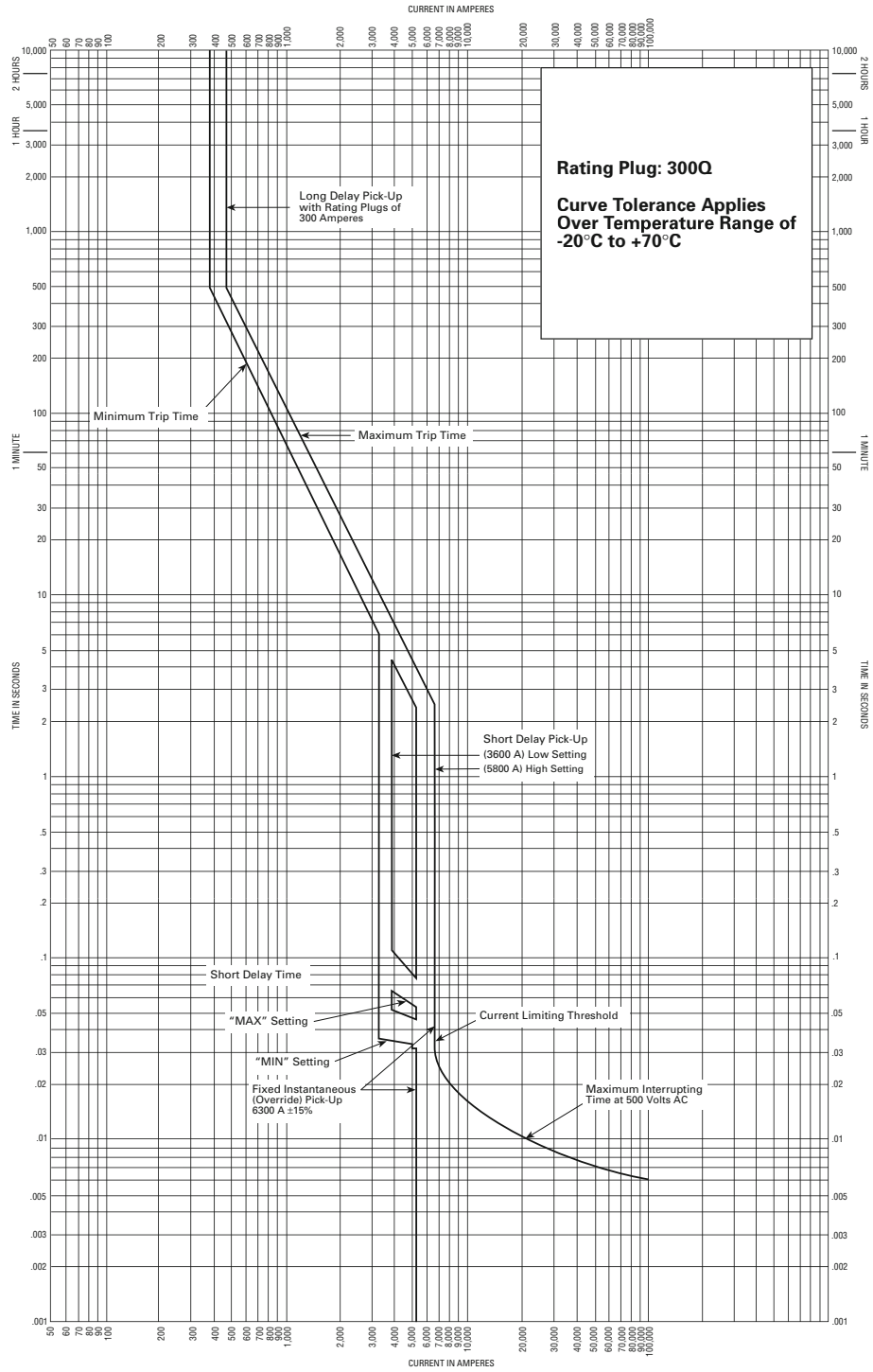

**TIME-CURRENT CURVES FOR AQB-LL400QS CIRCUIT BREAKER WITH 300 AMPERE RATING PLUG**



# Types AQB-L400, AQB-LL400

## Characteristic Time-Current Curves

Navy Type AQB-LL400QS  
Circuit Breaker

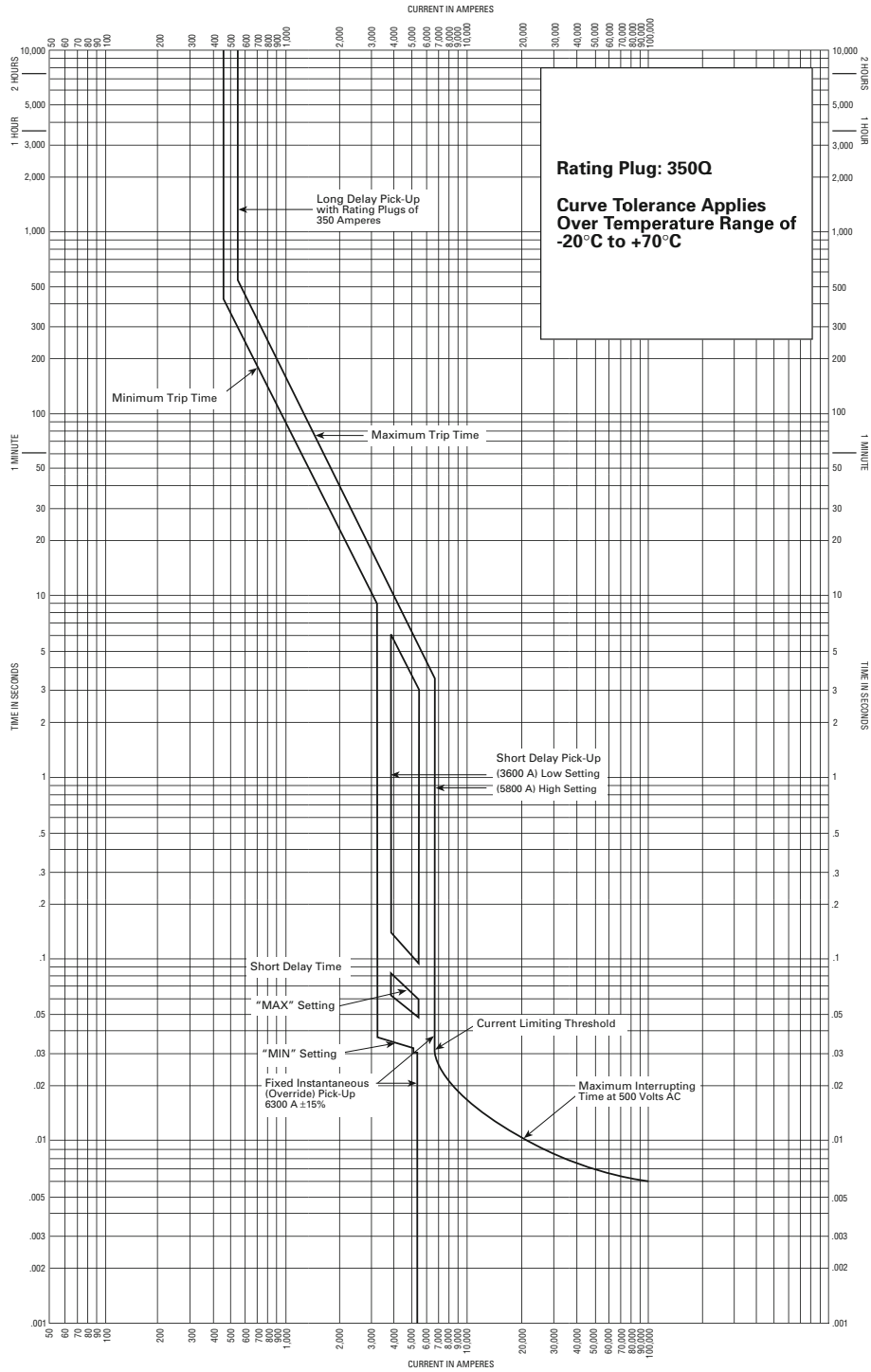

**TIME-CURRENT CURVES FOR AQB-LL400QS CIRCUIT BREAKER WITH 350 AMPERE RATING PLUG**

# Characteristic Time-Current Curves

Navy Type AQB-LL400QS  
Circuit Breaker

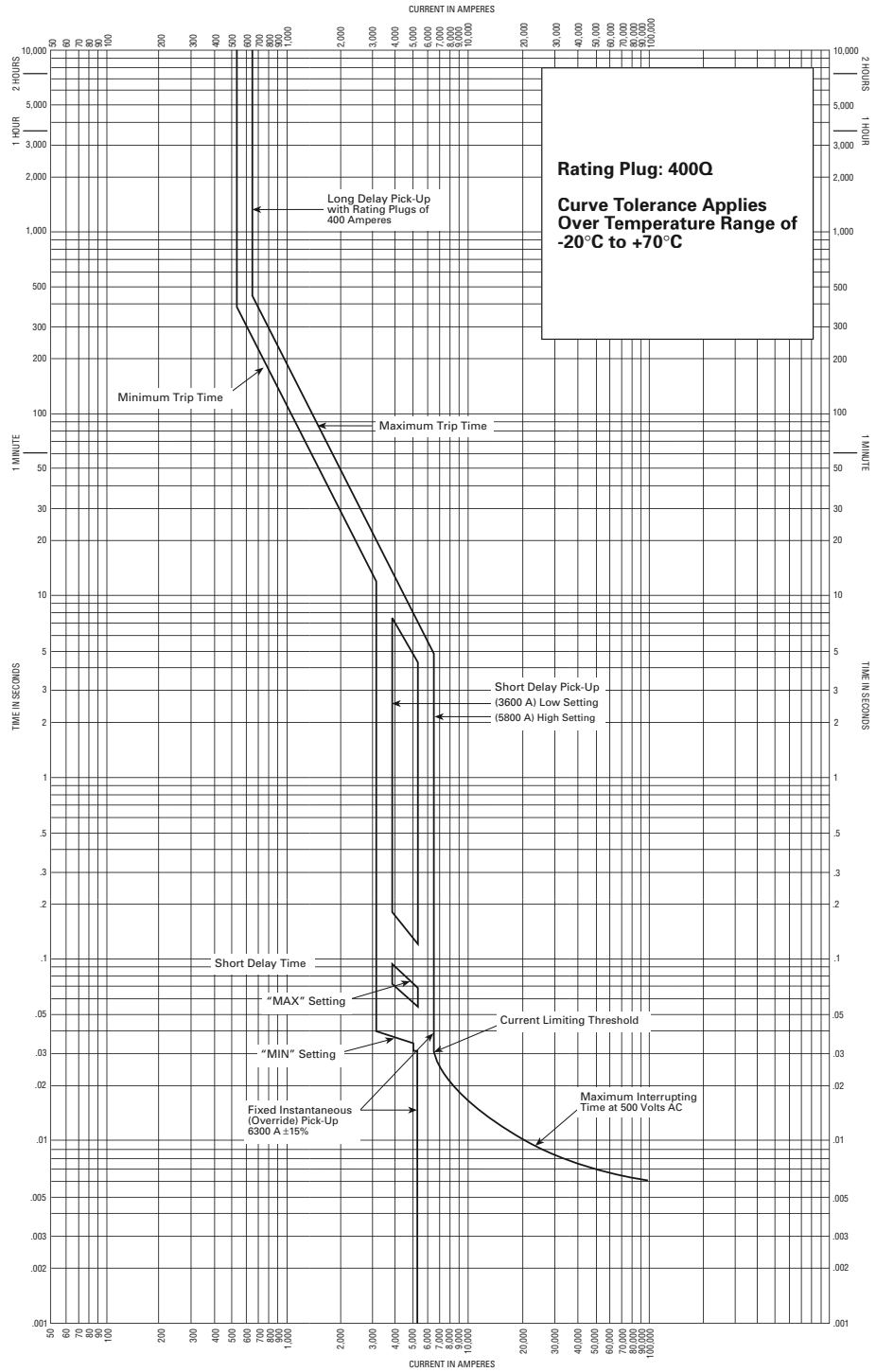

**TIME-CURRENT CURVES FOR AQB-LL400QS CIRCUIT BREAKER WITH 400 AMPERE RATING PLUG**

# Type NQB-A803

## Circuit Breakers for Naval Shipboard Use — Type NQB-A803

500 Volts ac, 800 Amperes at 60 Hz, 650 Amperes at 400 Hz



### Specifications: MIL-C-17361

- 800 amperes at 60 Hz, 650 amperes at 400 Hz.
- 500 volts ac, 60/400 Hz.
- 3-Pole.

### Interrupting Rating

- Non-overcurrent protection.
- Class: Hi Shock MIL-S-901D, 50°C ambient.

## NQB-A803 CIRCUIT BREAKER PRODUCT SELECTION ①

TYPE NQB-A803	COMPLETE BREAKER	
	STYLE NUMBER	NATIONAL STOCK NUMBER
Rear Connect	1488D90G10	—
Front Connect	1488D90G20	—
Front Connect with 1A1B Aux. Contact	1488D90G30	—
Front Connect with 1A1B Aux. Contact and Long Studs (BIW Style)	1488D90G31	—

① For list prices, see Price and Availability Digest (PAD).

## ACCESSORIES

DESCRIPTION	STYLE NUMBER
Block Assembly, 3-Pole	2614D53G07
Auxiliary Switch, <b>FACTORY INSTALL ONLY</b>	4214B63G01

### Note:

AIC ratings are based on 3-phase average asymmetrical current.

**Outline Dimensions  
 NQB-A803 — Dimensions  
 in Inches**

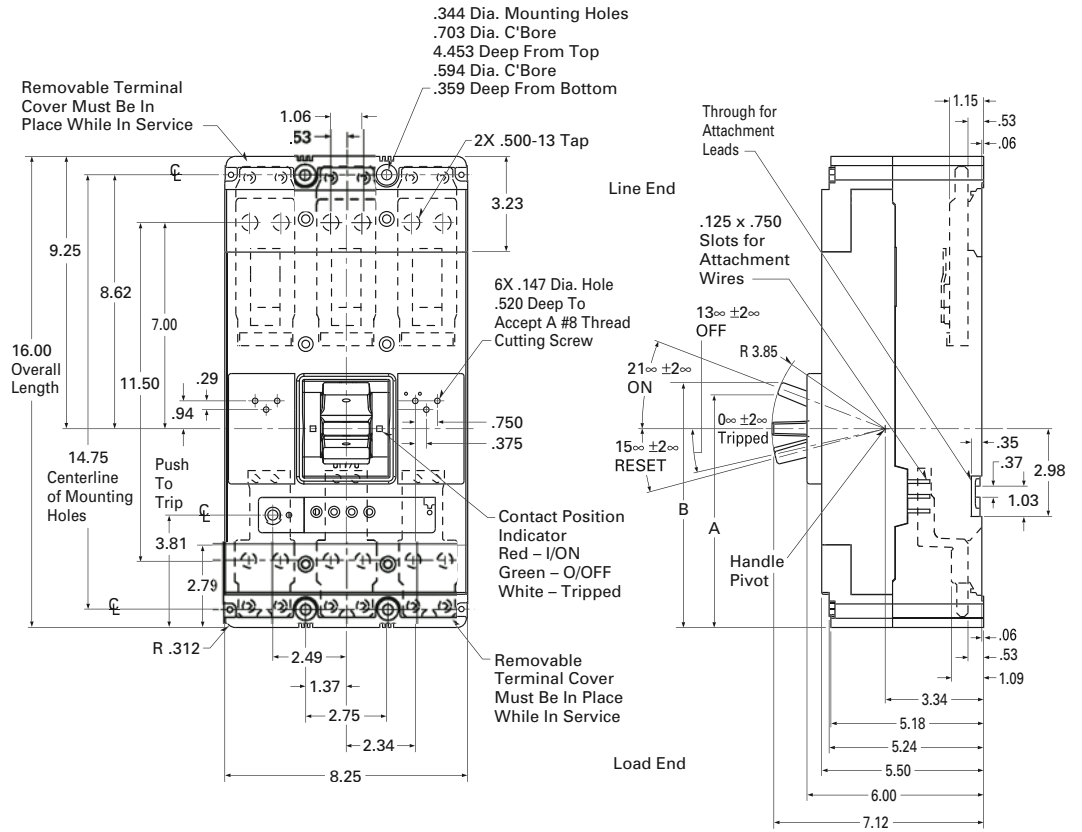

Breaker Status	Dimension	
	A	B
On	7.9	8.3
Off	6.5	6.9
Tripped	5.7	6.1
Reset	5.6	6.0

Handle Forces In Handle at Center Line Hole	
Off - On	130 Lb.
On - Off	105 Lb.
Trip - Reset	160 Lb.

# Types AQB-A1601, NQB-A1601

**Note:** A1601 PRODUCTS ARE NO LONGER AVAILABLE.

## Circuit Breakers for Naval Shipboard Use — Types AQB-A1601, NQB-A1601 Breakers

500 – 1600 Amperes; 500 Volts,  
60 Hz ac, 75,000 Amperes I.C.



Breaker Only



Breaker and Mounting Base

**Note:**  
AQB-A1601 are sold for replacement only. They are no longer on the Navy Qualified Products List.

### Specification: MIL-C-17361

- 500 – 1600 Amperes.
- 500 Volts ac, 60 Cycles Only, 3-Pole, 50°C Ambient.

### Interrupting Rating

- 75,000 Amperes ac (Without Delayed Instantaneous).
- 50,000 Amperes ac (With Delayed Instantaneous).

Class: Hi Shock MIL-S-901  
Vibration: MIL-STD-167-1  
Material and Workmanship: MIL-E-917

AQB-A1601 circuit breakers are designed for installation in switchboards for protection of generators and feeder and branch circuits.

A complete breaker consists of a breaker plus mounting base and is available with numerous attachments such as electrical operator, shunt trip, undervoltage release and auxiliary switches to perform varied auxiliary functions.

Trip units for these breakers have an adjustable instantaneous trip and are listed with and without delayed instantaneous trip for system coordination.

NQB-A1601 Breakers have a continuous rating of 1600 amperes. They are used only as disconnects since they do not have an automatic trip device.

**Note:**  
Breakers with ratings other than those listed above are considered as special and full descriptive data must be provided.

**400 cycle breakers are not available.**

## AQB-A1601 AND NQB-A1601 3-POLE, 500 VOLTS, 60 CYCLES AC CIRCUIT BREAKER PRODUCT SELECTION ①

### INSTANTANEOUS BREAKER ONLY, CONSISTS OF:

TYPE	CONT. AMPERE RATING	TRIP SETTING AC AMPERES		FRAME (INCLUDES STABS)		TRIP UNIT	
		LOW	HIGH	STYLE NUMBER	NATIONAL STOCK NUMBER	STYLE NUMBER	NATIONAL STOCK NUMBER
<b>Without Delayed Instantaneous Trip</b>							
AQB	600X	2000	6000	372D522G02	5925-01-105-4401	372D523G01	—
AQB	600XM	4000	12000	372D522G02	5925-01-105-4401	372D523G03	—
AQB	800X	2000	6000	372D522G02	5925-01-105-4401	372D523G07	—
AQB	1000X	2000	6000	372D522G02	5925-01-105-4401	372D524G03	5925-00-520-4743
AQB	1200X	2000	6000	372D522G02	5925-01-105-4401	372D524G05	—
AQB	1400X	4000	12000	372D522G02	5925-01-105-4401	372D524G07	—
AQB	1600X	4000	12000	372D522G02	5925-01-105-4401	372D524G09	5925-00-406-6131
NQB	1600	—	—	372D522G02	5925-01-105-4401	372D524G10	—
<b>With Delayed Instantaneous Trip (XT1 — Minimum Time Delay .0417 – .0458 Seconds)</b>							
AQB	500XT1	2000	6000	372D522G02	5925-01-105-4401	374D211G01	—
AQB	800XT1	2000	6000	372D522G02	5925-01-105-4401	374D211G07	—
AQB	1000XT1	2000	6000	372D522G02	5925-01-105-4401	374D212G03	—
AQB	1200XT1	2000	6000	372D522G02	5925-01-105-4401	374D212G05	5925-00-102-6086
AQB	1600XT1	4000	12000	372D522G02	5925-01-105-4401	374D212G09	5925-00-727-7574
<b>With Delayed Instantaneous Trip (XT2 — Maximum Time Delay .0750 – .0708 Seconds)</b>							
AQB	500XT2	2000	6000	372D522G02	5925-01-105-4401	374D221G01	—
AQB	800XT2	2000	6000	372D522G02	5925-01-105-4401	374D221G07	—
AQB	1200XT2	2000	6000	372D522G02	5925-01-105-4401	374D222G05	5925-00-727-7555
AQB	1600XT2	4000	12000	372D522G02	5925-01-105-4401	374D222G09	5925-00-103-4248

① For list prices, see Price and Availability Digest (PAD).

**Note:** A1601 PRODUCTS ARE NO LONGER AVAILABLE.

### Mounting Base



For switchboard mounting. Includes back connectors for switchboard bus and male stabs to engage breaker. Matching stabs are supplied with breaker frame.

**Note:**  
Can be field mounted. Consult factory for information.

Style Number: 373D307G02

National Stock Number:  
6110-01-178-5434

### Electrical Operator



Mounts to front of breaker for remote operation. 450 volt ac rating utilizes a transformer in conjunction with a 120 volt motor. If automatic reset is desired, order the circuit breaker with optional Automatic Reset Switch (See Optional Additions).

**Note:**  
Can be field mounted. Consult factory for information.

RATING	STYLE NUMBER	NATIONAL STOCK NUMBER
120 Vac	<b>1371D38G06</b>	None
450 Vac	<b>1371D38G08</b>	Assigned

### Optional Additions

**Note:**  
Can be field mounted. Consult factory for information.

#### Shunt Trip

Mounts in right pole only. Has momentary rating only; coil leads must be wired in series with 1A contact of auxiliary switch. (28 Vdc/120 Vac or 120 Vdc/450 Vac.)

**Note:**  
Breaker can be supplied with either shunt trip or undervoltage release, but not both.

### Undervoltage Release

Mounts in right pole only.

**Note:**  
Breaker can be supplied with either shunt trip or undervoltage release, but not both.

### Auxiliary Switch

Mounts in left pole only. 4 contacts, any combination of A's and B's, (supplied as 2A and 2B unless specified) 8 contacts, any combination of A's and B's, (supplied as 4A and 4B unless specified).

### Automatic Reset Switch

For use with motor operator when an automatic reset function is required. Factory installed only.

### Cable Connector

Mounts to bus connector for cable connection. Each lug accepts four cables, 600 kcmil maximum 1 lug required per bus connector.

Style Number: 505C706G03

### Fungus, Moisture-Resistant Treatment

(JAN-C-173 or MIL-V-173):  
If specified, contact Eaton. External parts are coated; trip units are not treated.

### Drawings

Master plan: 900J442

- Sheet 1 of 4: Breaker Only and Wiring diagrams.
- Sheet 2 of 4: Trip Unit, Curves and Attachments.
- Sheet 3 of 4: Mounting Base and Cable Connectors.
- Sheet 4 of 4: Motor Operator.

### Individual Reproductions

When required, reproductions of sheets 1 through 4 of master plan 900J442 can be ordered as follows:

#### TYPE REPRODUCTION

Vellum  
Prints (Paper)

### Technical Manual

NAVSHIPS No. 0962-014-5000. This booklet per MIL-M-15071. When required, order BVR-TM-576.

**Dimensions: Pages 102, 103, 104, 105 and 106.**

**Characteristic Curves: Pages 107 and 108.**

### NET WEIGHT, LBS.

DESCRIPTION	WEIGHT
Breaker Only	
AQB	151
NQB	148
Breaker Frame (AQB and NQB)	128
Trip Unit	
AQB	23
NQB	20
Mounting Base Only	75
Electrical Operator, 115 Volt	27
Electrical Operator, 450 Volt	35
Shunt Trip	3/4
Undervoltage Release	1-1/4
Auxiliary Switch	1-3/4
Cable Connector	3

For ordering information, see **Page 5**.

# Types AQB-A1601, NQB-A1601

## Outline Dimensions AQB and NQB Circuit Breaker Frame — Dimensions in Inches

NQB — Same except for trip unit  
nameplate.

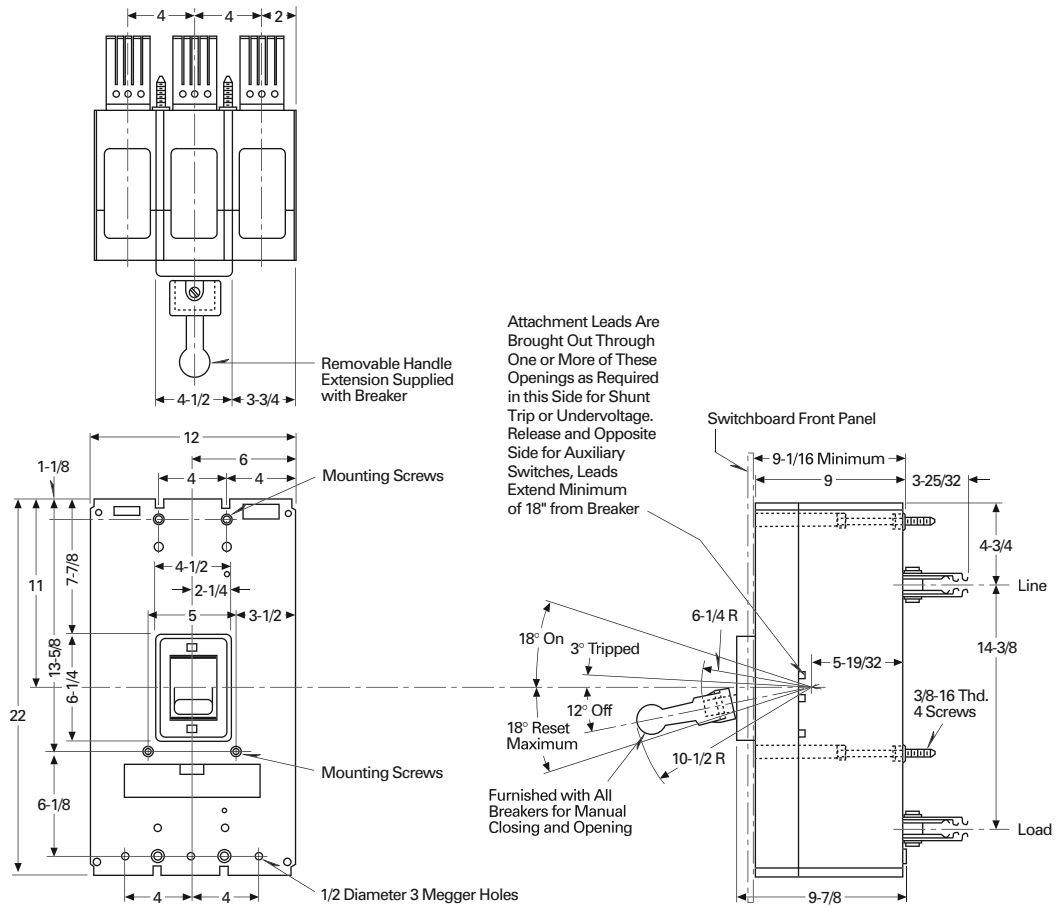

## Front Panel Cutout

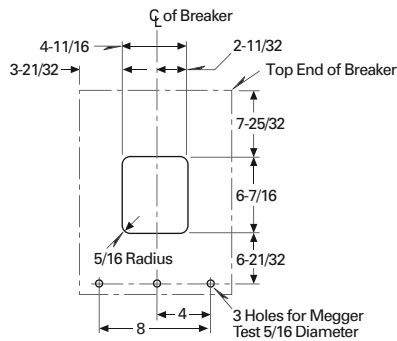

## Wiring Diagrams

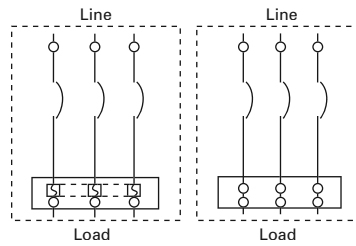

**AQB**

**NQB**

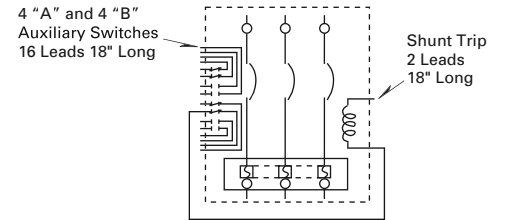
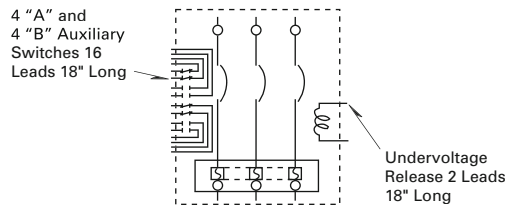

When undervoltage release and  
When shunt trip and auxiliary  
auxiliary switches are provided.  
switch are provided.

### Note:

The auxiliary switch must be used with each shunt trip. Connect one side of shunt trip in series with "A" contact (closed when breaker is closed) of auxiliary switch when connecting to power supply.



# Types AQB-A1601, NQB-A1601

## Outline Dimensions Mounting Base — Dimensions in Inches

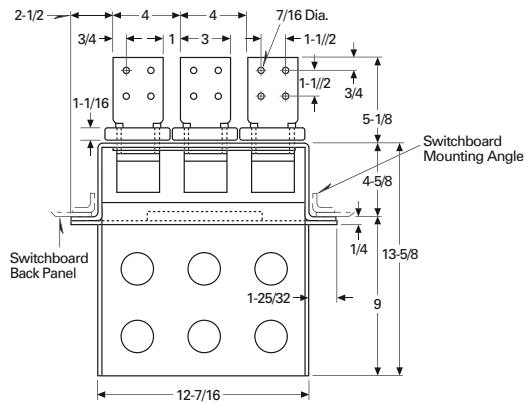

**TOP VIEW**

### MOUNTING BASE

With cable connections style 505C706G03 lug capacity — four 600 MCM cables per lug.

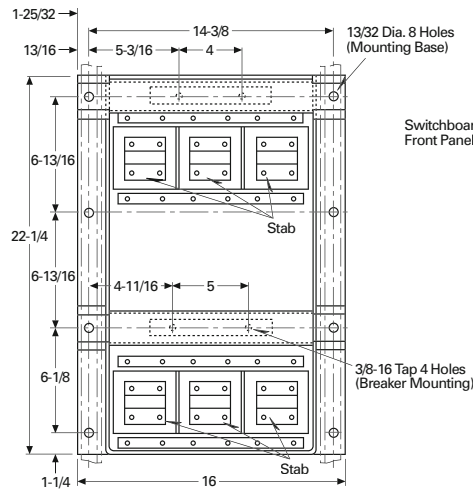

**FRONT VIEW**

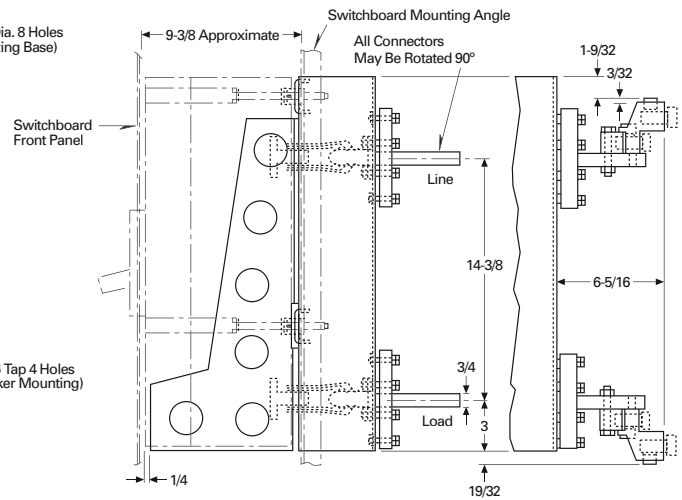

**SIDE VIEW**

## Cutout for Switchboard

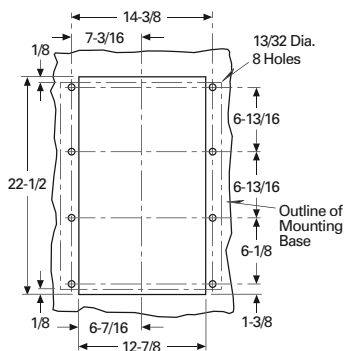

**BACK PANEL**

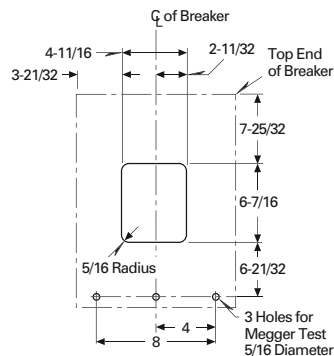

**FRONT PANEL CUTOUT**

**Outline Dimensions  
Electrical Operator —  
Dimensions in Inches**

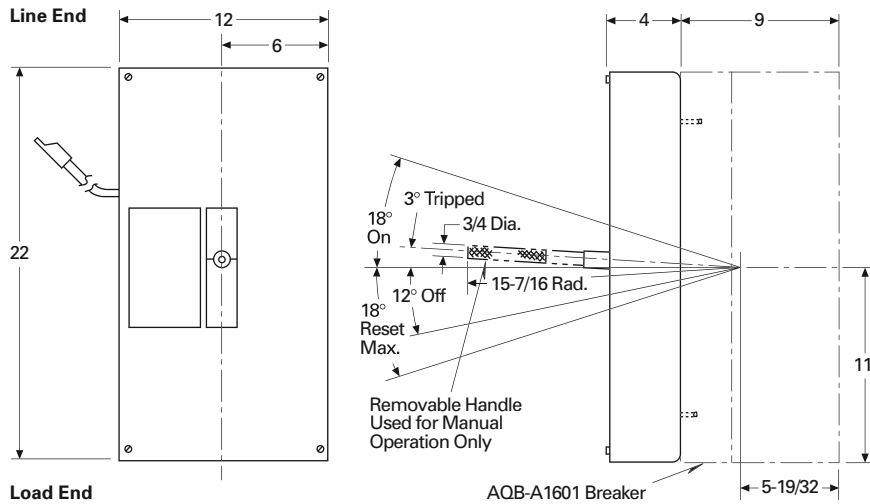

**Wiring Diagrams**

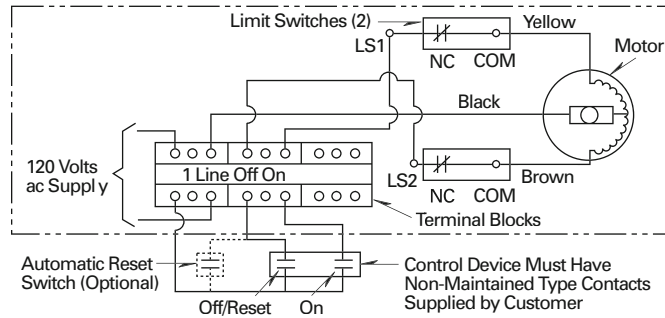

**WIRING DIAGRAM FOR 120-VOLT AC ELECTRICAL OPERATOR**

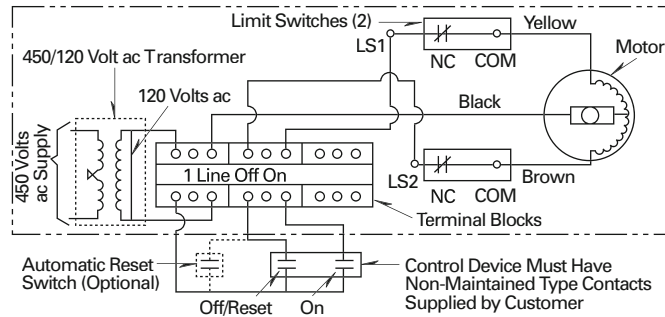

**WIRING DIAGRAM FOR 450-VOLT AC ELECTRICAL OPERATOR**

# Types AQB-A1601, NQB-A1601

## Switchboard Door Cutout — Dimensions in Inches

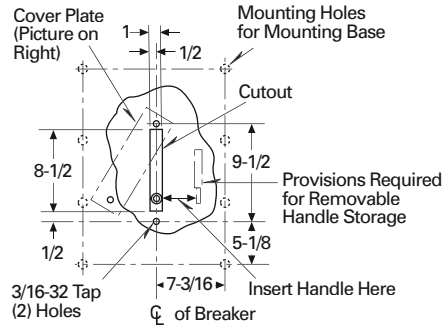

### SWITCHBOARD DOOR CUTOUT FOR ELECTRICALLY OPERATED BREAKER

## Gasketed Cover

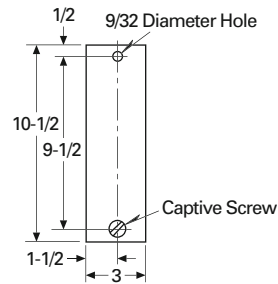

### GASKETED COVER FOR SWITCHBOARD DOOR CUTOUT (GASKET CEMENTED TO COVER)

## Electrical Operator

NOMINAL VOLTAGE	VOLTAGE RANGE	STYLE NUMBER
120 Volts ac	90 – 130	<b>1371D38G06</b>
450 Volts ac ①	360 – 500	<b>1371D38G08</b>

① A transformer is provided in the operator frame.

## Characteristic Time-Current Curves

### Operating Characteristics

- Trip unit rating 500 – 1600 amperes 50°C ambient.
- Cold start.
- 60 cycles.

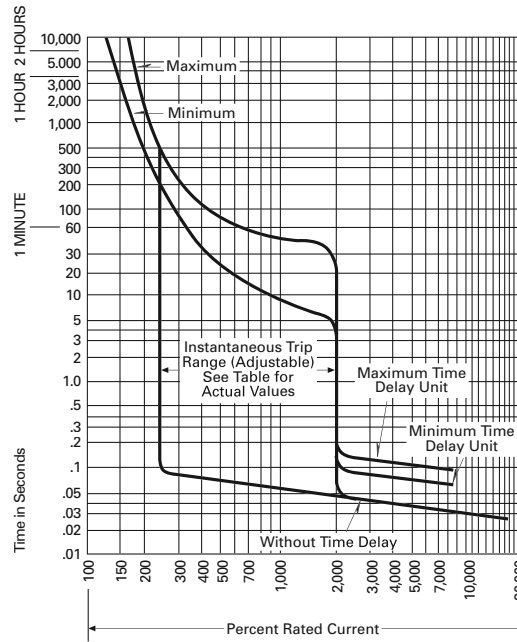

**AQB-A1601 STANDARD BREAKER**

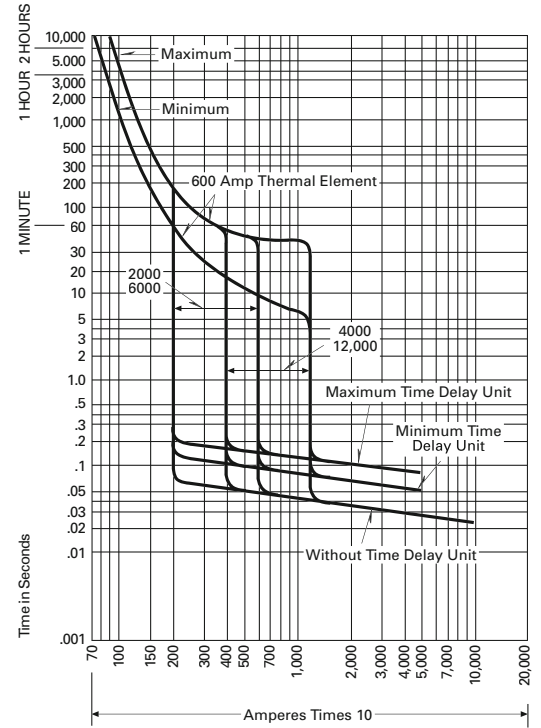

**EXPANDED TIME DELAY CURVE**

PERCENT OF TRIP ELEMENT RATING	TRIPPING TIME
600	20 to 60 Seconds
225	Less Than 1 Hour
150	1 Hour or More

### INSTANTANEOUS TRIP SETTING IN AMPERES ± 10%

AMPERE RATING	LOW	2	3	4	HIGH
500XT1	2000	3600	4000	4800	6000
500XT2	2000	3600	4000	4800	6000
600X	2000	3600	4000	4800	6000
600XM	4000	7500	8000	10,000	12,000
800X	2000	3600	4000	4800	6000
800XT1	2000	3600	4000	4800	6000
800XT2	2000	3600	4000	4800	6000
1000X	2000	3600	4000	4800	6000
1000XT1	2000	3600	4000	4800	6000
1200X	2000	3600	4000	4800	6000
1200XT1	2000	3600	4000	4800	6000
1200XT2	2000	3600	4000	4800	6000
1400X	4000	7500	8000	10,000	12,000
1600X	4000	7500	8000	10,000	12,000
1600XT1	4000	7500	8000	10,000	12,000
1600XT2	4000	7500	8000	10,000	12,000

**Characteristic Time-Current  
Curves, Continued**

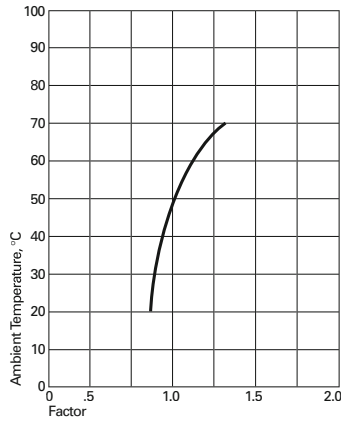

**DERATING CURVE**

Factor for change in current rating of circuit breaker with change in ambient temperature.

**Application**

1. Known Conditions:  
(A) Ambient  
(B) Load Current

To determine trip unit rating to be used when the load current and ambient are known, multiply the load current by the factor obtained from this curve for the known ambient. The result will be the ideal trip unit rating, however, since trip units are furnished with only standard ratings as per Navy Specs, select the standard trip unit whose rating is equal to or one rating higher than the ideal rating.

2. Known Conditions:  
(A) Ambient  
(B) Load Current

To determine the load current on which a trip unit may be used when ambient is known, divide the trip unit rating by the value obtained from this curve for the known ambient. The result will be the maximum load current on which the trip unit should be used.

# Types AQB-A1602, NQB-A1602

## Circuit Breakers for Naval Shipboard Use — Types AQB-A1602, NQB-A1602 Breakers

Type AQB-A1602 85,000  
Amperes Symmetrical I.C.  
400 – 1600 Amperes; 500 Volts  
ac, 60 Hz

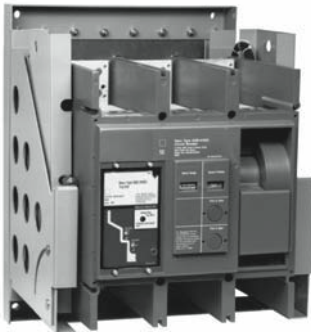

**AQB-A1602 Navy Breaker with  
Cassette**

The AQB-A1602 is a compact, low maintenance, low voltage circuit breaker in an insulated case providing high interrupting capability and a short-time withstand rating in a drawout frame.

It is a militarized version of the Cutler-Hammer Systems Power Breaker (SPB) and it meets the requirements of MIL-C-17361/15, MIL-S-901 Shock and MIL-STD-167-1 vibration.

The AQB-A1602 has protection features which are identical to those provided by Navy type air circuit breakers as per MIL-C-17587.

### Master Drawing

1376D08

### Outline Drawing

1377D30

### Technical Manual

6591C33H01

### Applications

- Main generator and tie breaker on small combatant ships.
- Load center feeder breaker on larger ships.
- Bus transfer switch breaker.

### Ratings

- AQB-A1602, NQB-A1602.
- 500 Vac, 60 Hz.
- 400 to 1600 Ampere via field replaceable rating plugs.
- 1600 ampere frame — 800 to 1600 amperes.
- 800 ampere frame — 400 to 800 amperes.
- 85 kA symmetrical rms interrupting rating or 100 kA asymmetrical rms.
- 50 kA symmetrical rms, 0.3 seconds short-time withstand rating.

### Trip Unit Characteristics

- Long time pickup — fixed at 150% of rating plug.
- Long time delay — see trip curve.
- Short time pickup — adjustable at 2, 2.5, 3, 4, 5, 6, 7 or 8 times rating plug.
- Short time delay — adjustable at 1 (instantaneous), 0.10, 0.20 or 0.30 seconds.
- Instantaneous pickup (override) factory selectable at 10, 15 or 20 times frame rating.

### Features

- Affordable.
- Compact and lightweight.
- Full line of field installable attachments.
- Secondary contacts automatically disconnect.
- “T” connector on drawout cassette allows switchboard bus runs to be vertical or horizontal.
- Cassette has self-contained rail extensions for withdrawing the breaker
- Integral spring stored energy electric operator or manual operation.
- Solid-state electronic trip unit with adjustable short-time protection.
- Portable Test Kit for field testing Catalog number STK2.

# Types AQB-A1602, NQB-A1602

## AQB-A1602 AND NQB-A1602 CIRCUIT BREAKER PRODUCT SELECTION

TYPE	STYLE NUMBER	NATIONAL STOCK NUMBER
AQB-A1602 Circuit Breaker (800 Ampere Frame) ①	6649C53G01	—
AQB-A1602 Circuit Breaker (1600 Ampere Frame) ①	6649C53G02	—
NQB-A1602 Circuit Breaker ②	6649C53G03	—
Stationary Drawout Cassette	1377D26G01	5925-01-437-3920
Electronic Trip Unit	6605C06G02	—
Rating Plug, 400 Ampere ③	6635C58G12	—
Rating Plug, 480 Ampere ③	6635C58G11	—
Rating Plug, 560 Ampere ③	6635C58G10	—
Rating Plug, 640 Ampere ③	6635C58G09	—
Rating Plug, 700 Ampere ③	6635C58G08	—
Rating Plug, 800 Ampere ③	6635C58G07	—
Rating Plug, 800 Ampere ④	6635C58G06	—
Rating Plug, 900 Ampere ④	6635C58G05	—
Rating Plug, 1000 Ampere ④	6635C58G04	—
Rating Plug, 1200 Ampere ④	6635C58G03	—
Rating Plug, 1400 Ampere ④	6635C58G02	—
Rating Plug, 1600 Ampere ④	6635C58G01	—
Shunt Trip (with Cutoff Switch), 115 Vac	6591C53G01	—
Shunt Trip (with Cutoff Switch), 450 Vac	6591C53G02	—
Undervoltage Release, 115 Vac	6591C54G01	—
Auxiliary Switch, 4A/4B ⑤⑥	6591C25G51	—
Auxiliary Switch, 8A/8B ⑤ Qty. 2	6591C25G51	—
Cell Switch, 115 Vac ⑥	5075A33H01	—
Electrical Operator, 115 Vac	6591C55G01	—
Spring Release, 115 Vac ⑥	6591C56G01	—
Lifting Beam	1375D91G01	—

① Instantaneous override factory set at 20x as standard.

② NQB-A1602 does not provide over-current protection; switch only.

③ Rating plugs for use with 800 ampere frame only.

④ Rating plugs for use with 1600 ampere frame only.

⑤ Auxiliary switches rated 115 – 450 Vac, 10 amperes.

⑥ Comes standard with breaker or cassette.

**Outline and Mounting Dimensions AQB-A1602 and NQB-A1602 Circuit Breakers and Stationary Element — Dimensions in Inches**

Contact Eaton for additional details.

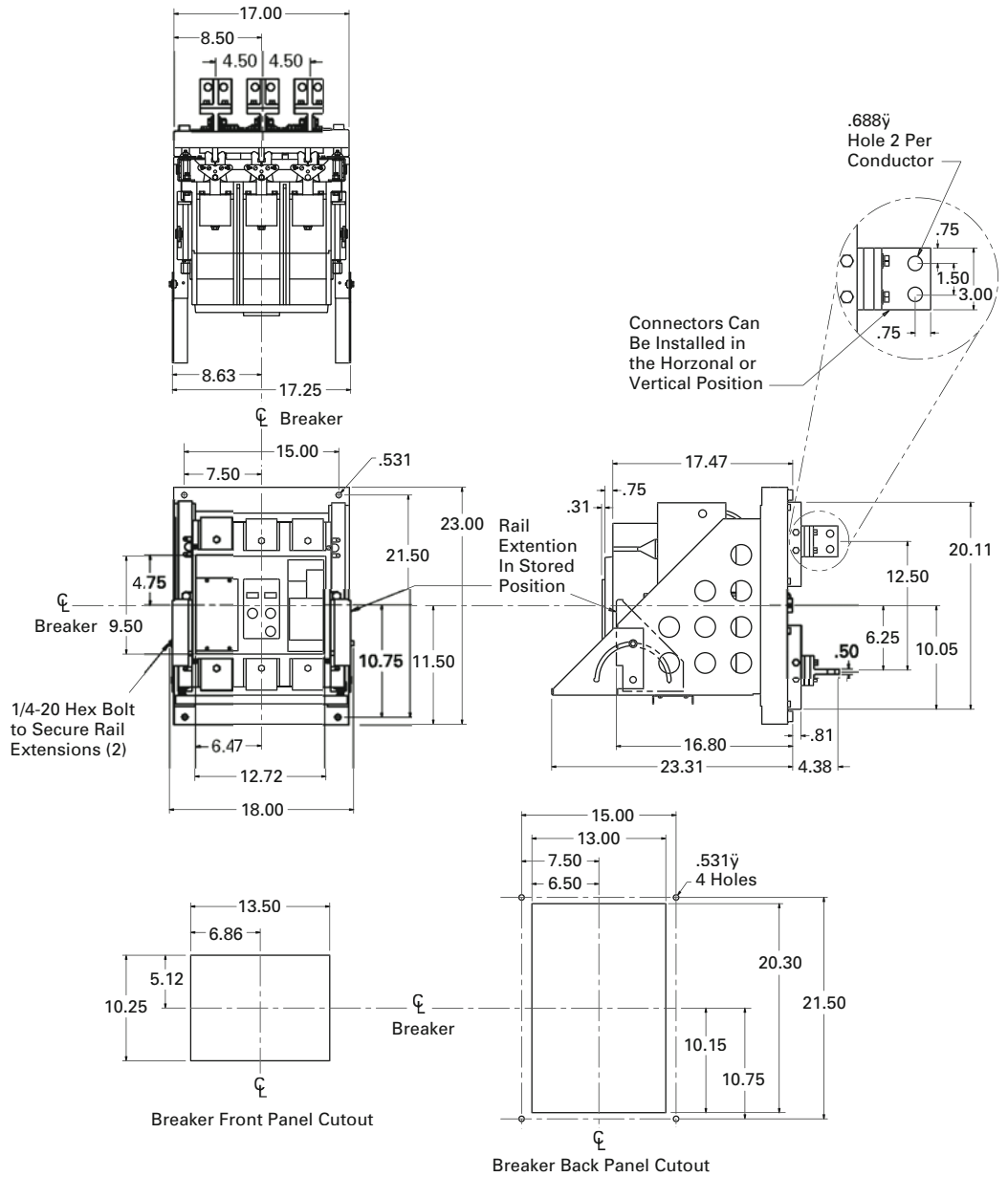

**NET WEIGHT**

DESCRIPTION	NET WEIGHT, LBS. (KG)
Circuit Breaker	159 (72)
Motor Operator	145 (66)
Mounting Block	80 (36)
Front Connected Terminals (Set of Three)	5 (2)



## Characteristic Time-Current Curves

Navy Type AQB-A1602  
Circuit Breaker

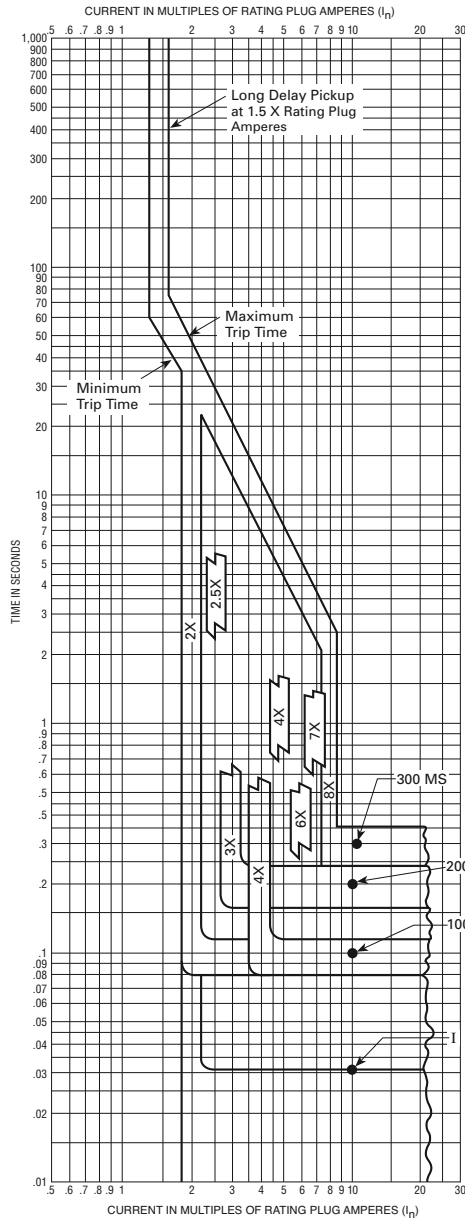

**CURVE NO. SC-7212-99**

## Circuit Breaker Time/Current Curves

### Type AQB-A1602 Circuit Breakers

Available Rating Plugs Frame Rating (amperes)	Style No.	Plug Rating (amperes)
1600	6635C58G01	1600
1600	6635C58G02	1400
1600	6635C58G03	1200
1600	6635C58G04	1000
1600	6635C58G05	900
1600	6635C58G06	800
800	6635C58G07	800
800	6635C58G08	700
800	6635C58G09	640
800	6635C58G10	560
800	6635C58G11	480
800	6635C58G12	400

**Short Time Current Rating** – 50kA, rms, symmetrical amperes  
**Interrupting Rating @ 500 Vac, 60 Hz** – 85 kA, rms, symmetrical (100 kA, rms, asymmetrical)

**Note**  
Trip units are suitable for functional field testing with Test Kit Cat. No. STK2. For field testing using primarily injection method follow NEMA publication AB-2-1984.

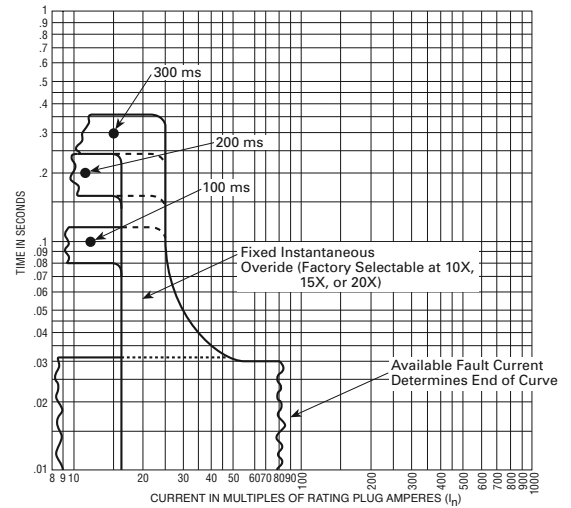

# Types ACB 1600/2000HR – 3200/4000HR

**Note:** COMPLETE NEW BREAKERS ARE NO LONGER AVAILABLE.

## Circuit Breakers for Naval Shipboard Use — Types ACB 1600/ 2000HR — 3200/ 4000HR Breakers

500 Volts ac, 4,000 Amperes  
Maximum, 85,000 Amperes  
Symmetrical I.C.



**ACB3200/4000HR Air Circuit Breaker  
Shown Mounted in its Stationary  
Drawout Cassette**

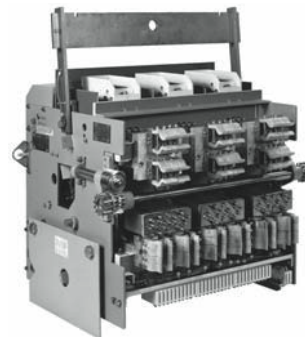

**ACB3200/4000HR Air Circuit Breaker  
Removable Element, Rear View, with  
Lifting Beam**

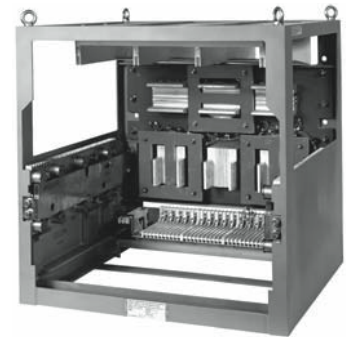

**ACB3200/4000HR Air Circuit Breaker  
Stationary Drawout Cassette**

The circuit breaker is a device for interrupting, in air, a circuit between separable contacts under normal and abnormal conditions. It is supplied as a complete removable assembly including drawout, stationary frame and secondary control contacts in a three-pole construction.

The main power circuit consists of butt type main and arcing contacts. The function of the main contacts is to carry full-rated current and short circuit current when the circuit breaker is closed. The arcing contacts transfer the current from the main contacts to the arc chutes when breaking currents.

Each contact assembly is fastened to a common driveshaft via an insulated drive link. By rotating this driveshaft, the operating mechanism actuates the contacts of all poles simultaneously. These contacts are quick make and break, under all conditions.

The circuit breaker is of the trip free design in any position of the closing stroke and may be tripped before the contacts touch. While an open operation exists, the moving contacts will return and remain in the open position even if a manual or electrical close operation is maintained. The closing mechanism will not reclose the circuit breaker after such tripping until the closing control circuit is opened and then reclosed.

At the top of the circuit breaker, surrounding each contact structure, is the arc chute assembly. It is designed to extinguish the arc that is drawn when the contacts open.

Each contact assembly is mounted on an insulated panel bolted to the back panel of the circuit breaker's removable element.

The moving contact assembly is designed to make or break a main power circuit by moving onto or out from the fixed main contacts.

Three current sensors are installed. Two current sensors are fixed to the stationary element and surround the lower outer main poles. The third current sensor is fixed to the stationary element and surrounds the top center main pole. These ring-type current transformers are designed to monitor the current and to signal the solid state overcurrent trip device to trip the circuit breaker whenever current exceeds its long time delay and short time pickup settings.

Instantaneous overcurrent trip devices are attached to the two lower outer poles of the circuit breaker. These calibrated devices will trip the circuit breaker whenever the current exceeds the predetermined instantaneous setting.

The operating mechanism transmits the closing force to the drive shaft. It is centrally located in the front of the circuit breaker.

The ON/OFF indicator, located in the front of the circuit breaker, is fastened to the drive shaft above the operating mechanism. This device indicates whether the circuit breaker is open (OFF) or closed (ON).

The trip knob located in the front of the operating mechanism provides a means for tripping the circuit breaker manually.

Anti-rebound catches are provided to prevent reclosing of the contacts when the circuit breaker is tripped. These are mounted on the side plates of the breaker. They also function as shock catches preventing contacts of an open breaker from closing.

The shunt trip circuitry, which acts through the magnetic trip device located on the left side of the operating mechanism assembly, provides the means for electrically tripping the circuit breaker from a remote location with out regard to load conditions in the circuit. Customer supplied 120 Vac Power (standard) is converted to 30 Vdc by a control panel for the magnetic trip device.

The auxiliary switch, actuated by the opening and closing of the circuit breaker, is incorporated to open and close certain contacts in protective and control circuits. The auxiliary switch is linked to the driveshaft which is located above the operating mechanism.

# Types ACB 1600/2000HR – 3200/4000HR

## ACB 1600/2000HR – 3200/4000HR Breakers, Continued

Directly beneath the operating mechanism is the solenoid closing coil mechanism which provides the closing force for electrical closing of the circuit breaker.

The closing contactor, attached to the left-hand side of the removable element frame, controls the supply of current to the closing coil (customer supplied 450 Vac).

A rectifier unit permits the use of an alternating current source for closing the circuit breaker.

Primary disconnect assemblies are mounted on each phase of the circuit breaker to provide a separable electrical connection between the supply circuit and the circuit breaker.

A movable secondary disconnect assembly, fastened to a channel structure mounted on the bottom rear of the circuit breaker removable element, permits the withdrawal of the circuit breaker without disconnecting the wiring.

An undervoltage trip device (when supplied) mounted to the right-hand side of the mechanism will trip the circuit breaker when the undervoltage coil is de-energized by loss of voltage.

The lockout mechanism prevents the circuit breaker from being racked in or out while the circuit breaker is closed, and prevents closing of the circuit breaker while the removable element is being reached in or out.

The circuit breaker may be racked into or out from the Connected position from or to the Disconnected position by turning the withdrawal mechanism drive shaft which is located on the right of the operating mechanism.

Provision is provided for two indicating lamps. These lamps are only supplied when specified. A “Tripped on overcurrent” lamp is always provided.

### NET WEIGHT

DESCRIPTION	NET WEIGHT, LBS. (KG)
2000 A Breaker	318 (144)
2000 A Cassette	180 (82)
4000 A Breaker	658 (299)
4000 A Cassette	495 (225)

For ordering information or additional literature, consult Eaton.

**Outline Dimensions  
ACB 1600/2000HR Breaker  
— Dimensions in Inches**

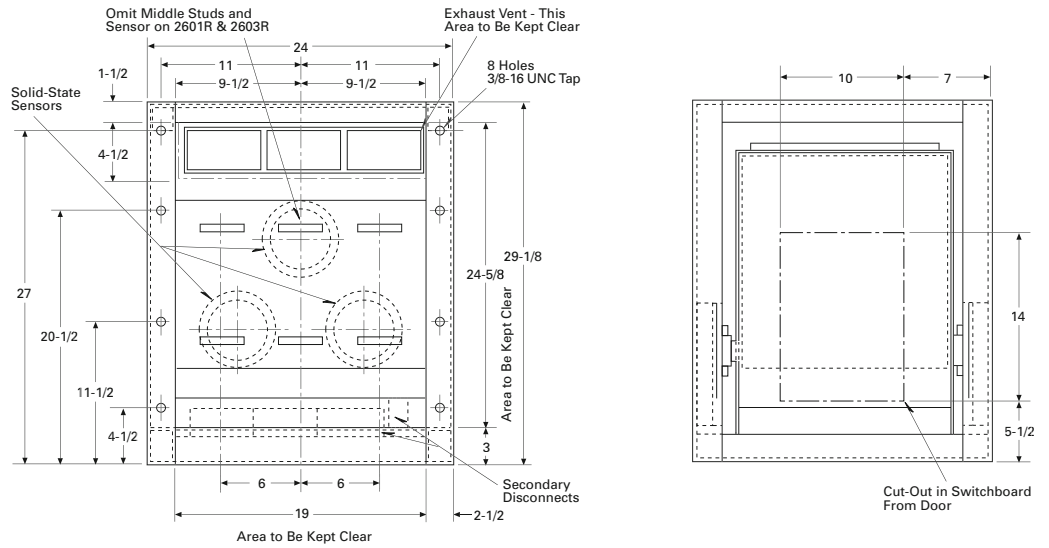

**REAR VIEW**

**FRONT VIEW**

**Outline Dimensions for  
Switchboard Installation  
of Stationary Element  
(Cassette)**

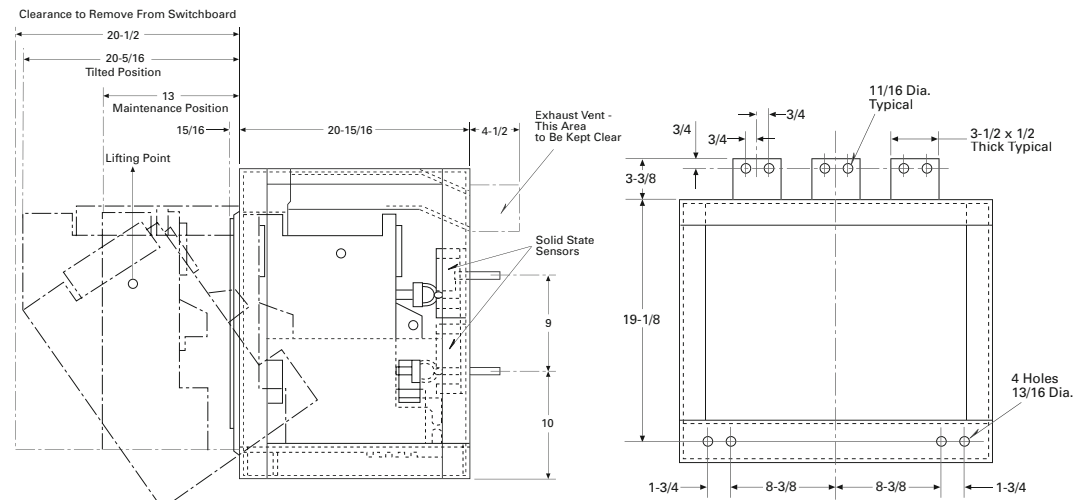

**RIGHT SIDE VIEW**

**BASE VIEW (BASE MOUNTING)**

Types ACB  
1600/2000HR –  
3200/4000HR

Outline Dimensions  
ACB 3200/4000HR Breaker  
— Dimensions in Inches

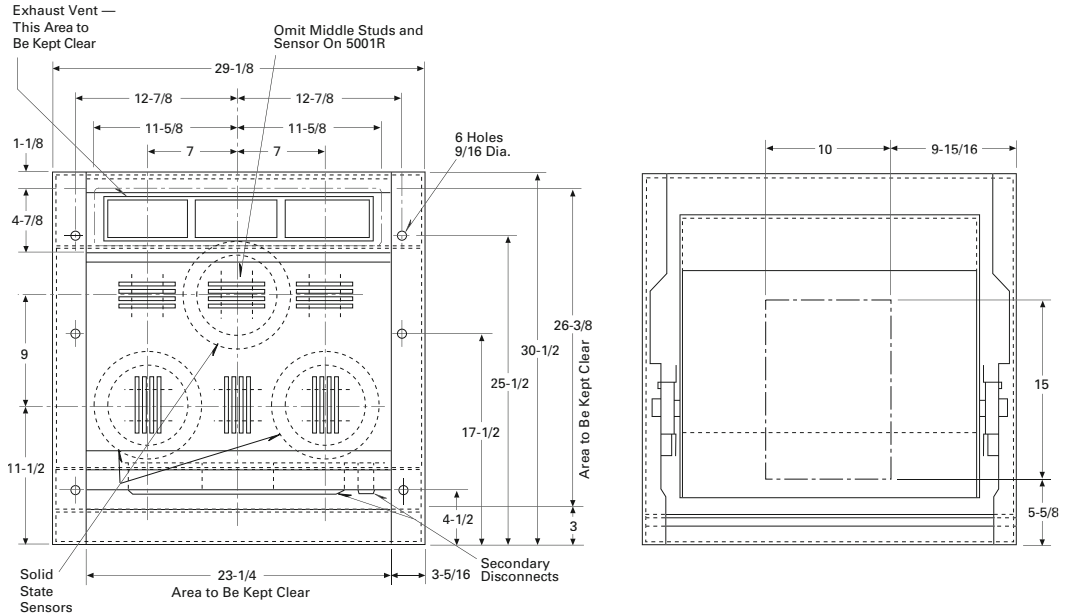

REAR VIEW

FRONT VIEW

Outline Dimensions for  
Switchboard Installation  
of Stationary Element  
(Cassette)

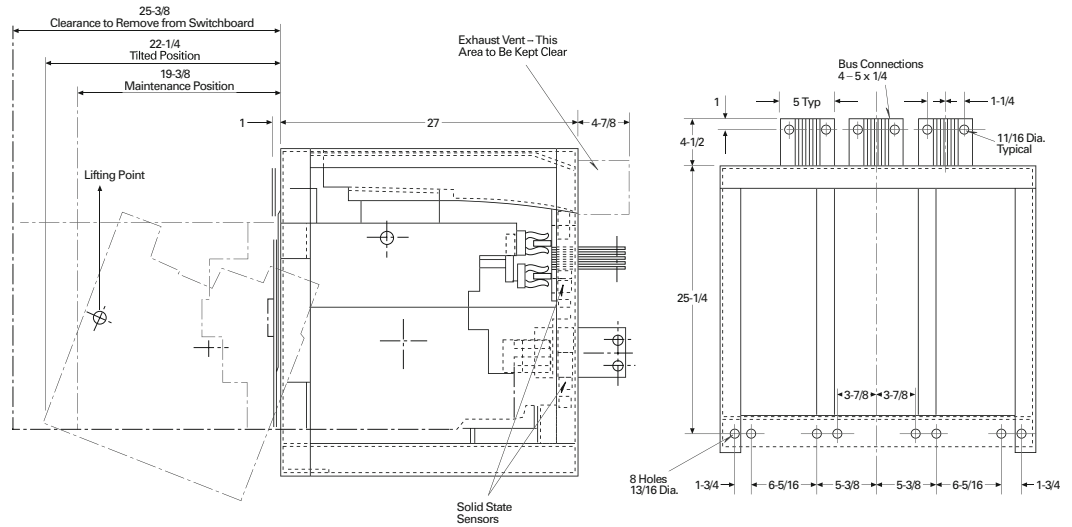

RIGHT SIDE VIEW

BASE VIEW (BASE MOUNTING)

# Characteristic Time-Current Curve

Navy Type ACB1600/2000HR – 3200/4000HR Circuit Breaker.

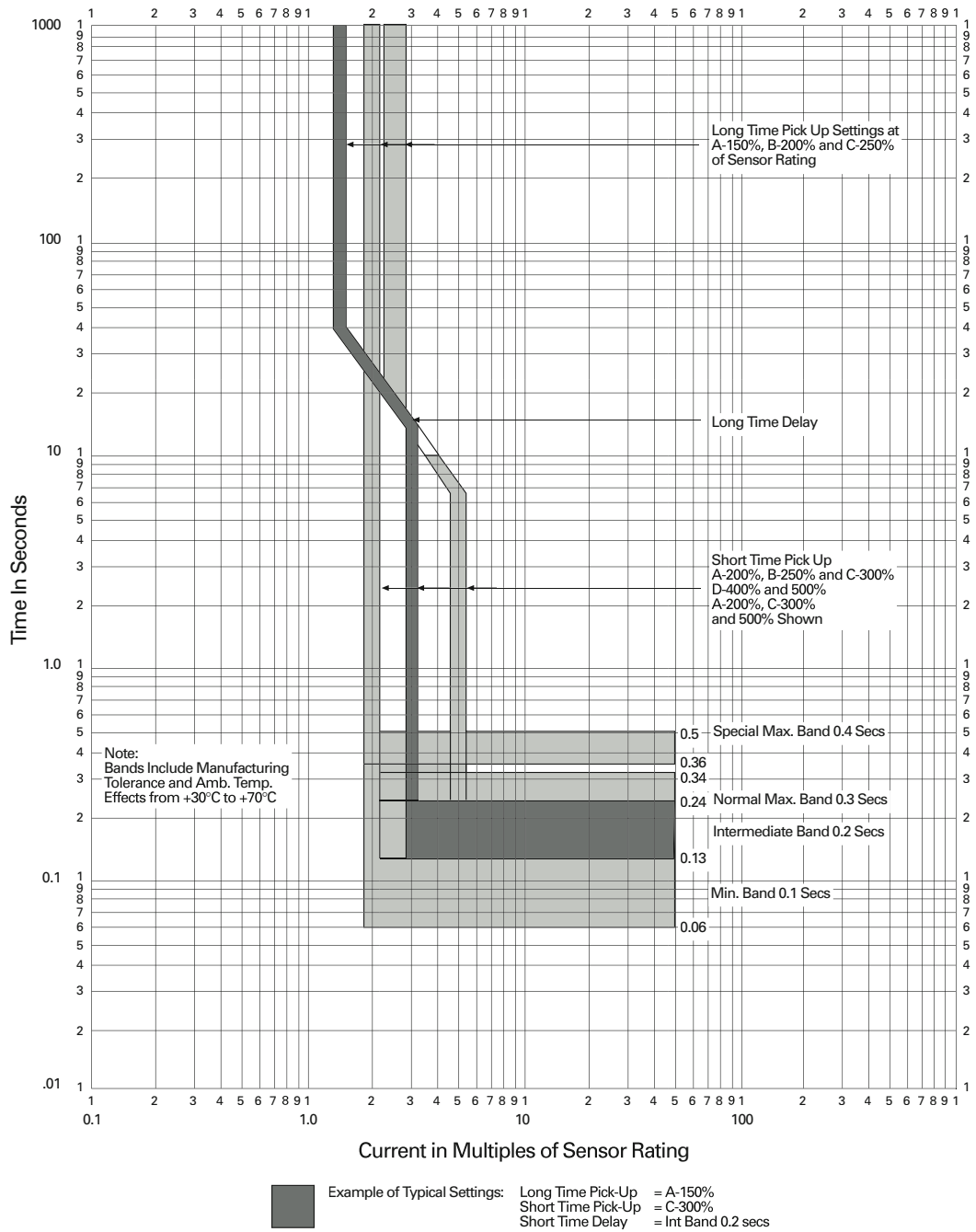

# Notes

Eaton's Electrical Sector is a global leader in power distribution, power quality, control and automation, and monitoring products. When combined with Eaton's full-scale engineering services, these products provide customer-driven PowerChain Management® solutions to serve the power system needs of the data center, industrial, institutional, public sector, utility, commercial, residential, IT, mission critical, alternative energy and OEM markets worldwide.

PowerChain Management solutions help enterprises achieve sustainable and competitive advantages through proactive management of the power system as a strategic, integrated asset throughout its life cycle, resulting in enhanced safety, greater reliability and energy efficiency. For more information, visit [www.eaton.com/electrical](http://www.eaton.com/electrical).

**Eaton Corporation**  
Electrical Sector  
1111 Superior Ave.  
Cleveland, OH 44114  
United States  
877-ETN-CARE (877-386-2273)  
[Eaton.com](http://Eaton.com)

© 2010 Eaton Corporation  
All Rights Reserved  
Printed in USA  
Publication No. PG01218003E / Z9397  
January 2010



PowerChain Management is a registered trademark of Eaton Corporation.

All other trademarks are property of their respective owners.