



*Rugged self-contained emergency lighting unit designed to perform in damp or harsh industrial environments.*

## Spectron® Series

Self-Testing/Self-Diagnostic Electronics System

Catalog Number	
Comments	Type



### Unit Features

- Completely self-contained
- Models operate for up to 4 hours
- Maintenance-free, lead-acid battery
- Fully adjustable dual lighting heads
- Gray finish, sealed and gasketed construction
- Remote fixture capability
- Available in 6- or 12-volt versions
- Temperature range: 10°C to 40°C (50°F to 104°F)
- UL924 Listed (Emergency Lighting)

### Spectron Features

- Meets 1998 UL standards for self-testing/self-diagnostic models
- Provides automatic self-diagnostic monitoring and testing of unit operation
- Automatically performs routine maintenance and assures operational readiness at all times
- Monitors charger and lamp operation
- Emergency lamps and transfer circuit monitored during self-test cycles and power failures
- Routine discharge cycles insure optimum battery performance and maximum useful life
- Automatic 1-minute self-test every 28 days and 30-minute self-test every 6 months
- Automatic battery protection
- Automatic unit transfer in brownout conditions
- Automatic AC lockout circuit
- Temperature compensated charger
- 15-minute retransfer delay
- Flashing LED indication of unit malfunction or test cycle
- All detected malfunctions retained in memory until corrected and retested
- Test switch allows a programmable 1, 5, 30 or 60-minute system check at any time

### Spectron Electronics

The Spectron self-testing/self-diagnostic electronics provide:

- Visual indication of AC power status
- Visual indication of all self-diagnostic test cycles
- Visual indication of unit malfunctions including:
  - Battery fault • Charger fault • Transfer fault • Lamp fault

### LED Indicators

#### Red Status LED

Under normal operating conditions, the red Status LED indicator will remain off. In the event the Spectron Controller detects a malfunction, the red Status LED will indicate the fault per the table at right.

Red Status LED Code	Description
One blink ON/pause	Battery not connected
Two blinks ON/pause	Battery fault
Three blinks ON/pause	Charger fault
Four blinks ON/pause	Transfer circuit fault
Five blinks ON/pause	Lamp head fault

#### Green Status LED

The green Status LED serves as both an AC power and a self-test indicator. During normal operation, the green status LED will be constantly illuminated, indicating the presence of AC power. During all automatic or manual self-test cycles, the green Status LED will blink at a 1 cycle per second rate.

#### Manual Tests

Using the unit test switch, users can initiate 1, 5, 30 or 60-minute diagnostic/discharge cycles per the table at right.

Initiating Action	Test Cycle
Press test switch once	1 minute
Press test switch twice	5 minute
Press test switch 3 times	30 minute
Press test switch 4 times	60 minute

### Product Selector

Fixture Type	Model No.	Voltage	Battery Type	Output Wattage			
				1 1/2 Hrs.	2 Hrs.	3 Hrs.	4 Hrs.
	N4X2	6	Lead-Acid	15	--	--	--
	N4X4	6	Lead-Acid	31	22	15	--
	N4X7	6	Lead-Acid	50	36	29	22
	N4X7-12V	12	Lead-Acid	50	36	29	22
	N4X14	6	Lead-Acid	100	79	61	44
	N4X14-12V	12	Lead-Acid	100	79	61	44
( )	Options (add suffix to model)						
	I	Spectron self-testing/self-diagnostic electronics					
	-0	Unit supplied without lighting heads <sup>(1)</sup>					
	-1	Unit supplied with one lighting head <sup>(1)</sup>					
	-L	Shatter Containment Lamp Option <sup>(2)</sup>					
	-A31	Auxiliary 3-conductor AC line cord - 120VAC					
	-A32	Auxiliary 3-conductor AC line cord - 277VAC					
( )	Accessories (order separately)						
	40G	Wire guard					
	GNXSB	Matching remote head - single <sup>(3)</sup>					
	GNXDB	Matching remote head - twin <sup>(3)</sup>					

(1) Not available on N4X21 unit.

(2) Protective lamp cover safely contains lamp fragments in the event of accidental breakage in sensitive areas such as food preparation or hospitals.

(3) Supplied with mounting plate. Specify voltage and wattage when ordering. Example: GNXSB0618. See "Remote Heads and Fixtures" Data Sheet 0602008 for available lamps.

### Dimensions

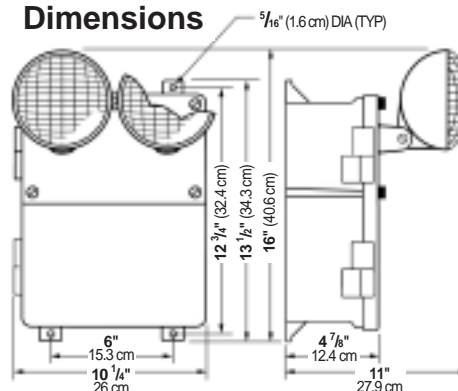

Hubbell Lighting, Inc.

**Construction**

**Unit Housing:** Sealed and gasketed case is constructed of thermoplastic polycarbonate in a gray finish. Hinged front cover is secured by means of stainless steel hardware. Battery compartment vented for safety.

**Lamp Housings:** Lamp housings and swivel assemblies constructed of flame-rated, UV stable thermoplastic in a gray finish. The lamp terminals are coated to resist corrosion and the lamp head swivel is sealed from the environment.

**Illumination**

**Lamp Type:** Incandescent sealed beam type

**Lamp Voltage:** 6 or 12 volts (model dependent)

**Lamp Wattage:** 7.2 watts (6 volt models), 9 watts (12 volt models)

**Rated Lamp Life:** 100 hours

**Photometrics**

SBT lamp (Horizontal Isofootcandle Distribution)

Photometrics measured by independent testing laboratory

6 volt, 7.2 watt SBT Lamp

12 volt, 9 watt SBT Lamp

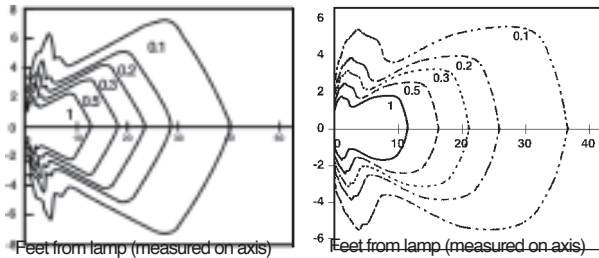

**Installation**

**Unit Mounting:** Units are provided with pre-drilled flanges for wall or beam mounting. The design permits top conduit entry for power and remotes. Drilling templates are provided.

**Wiring:** Connections for remote fixtures are fused. All AC connections made inside unit housing.

**Operating Temperature Range**

**All models:** 10°C to 40°C (50°F to 104°F)

**Electronics**

**Input:** 120/277VAC, 60 Hz. (standard)

**Charger:** Constant voltage, current limited, temperature compensated type

**Transfer:** Solid-state design

**Built-in Protection:** AC lockout, transformer isolation, low battery voltage disconnect, brownout protection and 15-minute retransfer delay

**Battery Recharge Cycle:** Per UL time standards

**Test Means:** Integral test switch

**Self-Diagnostic Operation**

**LED Indicators:** Red "Service Alert" LED indicator and Green "Operating Status" LED indicator

**Visual Fault Indications:** Battery fault, charger fault, transfer fault and lamp fault

**Service Alert Memory:** All detected malfunctions remain in memory until corrected and retested

**Self-Testing Operation**

**Automatic Test Cycles:** 1-minute self-test every 28 days (± 3.5 hours) and a 30 minute self-test every 6 months (± 1 day)

**Manual Tests:** Test switch allows a programmable 1, 5, 30 or 60 minute system check at any time

**Battery**

**Type:** Maintenance-free, lead-acid

**Power Consumption**

**120 or 277VAC:** 20 watts (maximum)

**Compliances**

UL 924

NFPA-101

**Warranty**

**Unit and Electronics:** 5 years full

**Battery:** 10 years (5 years full, 5 years pro-rata)

**Suggested Specifications**

Emergency lighting shall be provided by a Dual-Lite N4X Series I model designed for installation in damp or corrosive

environments. Construction shall be of thermoplastic polycarbonate in gray finish with matching hinged front cover. Unit battery compartment shall be vented for safety. Units shall be provided with pre-drilled mounting flanges for wall or beam mounting. The design will permit top conduit entry for power and remotes. Drilling templates shall be provided. Unit design will allow universal 120/277VAC, 60 Hz operation standard. Total unit output capacity shall be watts. Emergency illumination will be provided by (one)(two) unit mounted (6-volt, 7,2 watt)(12 volt, 9 watt) sealed beam type lighting heads. Lamp housings and swivel assemblies shall be constructed of flame-rated, UV stable thermoplastic in a gray finish. The lamp terminals will be coated to resist corrosion and the lamp head swivel shall be sealed from the environment. Emergency power source shall be a fully rechargeable, maintenance-free, lead-acid battery. Spectron electronics operation shall be fully automatic. Accidental discharge of the unit battery prior to energization will be prevented by an AC lockout circuit. The unit's green Status LED located on the Spectron display panel will illuminate to indicate the presence of AC power. The unit's red Status LED will blink after application of AC power if the battery connection is not completed. During normal operation, the unit's charging circuit will maintain the battery at full capacity and the Spectron Controller shall constantly monitor charger performance. Should the terminal voltage vary from design parameter values, the unit's red Status LED will blink, indicating a malfunction of the battery or charger. Upon interruption of normal AC power, or brownout conditions exceeding a 20% drop from nominal voltage, the Spectron Controller shall automatically switch the emergency lighting load to the battery. Emergency power will be provided for a minimum of 90 minutes. During emergency operation, the battery shall be protected from deep discharge by a low-voltage battery disconnect circuit. Upon return of normal utility power the unit will remain in emergency mode for a period of 15 minutes and the charger shall then begin a recharge cycle. The charger will bring the battery to full capacity within acceptable UL time standards. The Spectron Controller will automatically initiate a one minute discharge/diagnostic test every 28 days ± 3.5 hours and a 30-minute discharge/diagnostic test every 6 months ± 1 day. These tests will be designed to exercise the unit's battery and allow the Spectron Controller to analyze emergency operation performance. Any malfunction of the unit's transfer circuit or emergency lamps will cause the red Status LED on the unit's display panel to blink. Under normal operation, all red Status LED blinking indications of unit malfunction shall remain latched until corrected and retested. A manual test switch will allow a user-programmable 1, 5, 30 or 60-minute diagnostic/discharge test at any time. During all automatic and user initiated self-tests, the unit's green Status LED will blink to indicate a diagnostic cycle in process. User self-tests can be canceled at any time by pressing the test switch.

**NOTE: Self-testing, self-diagnostic models with over 80 watts of capacity require a minimum load of 35 watts for accurate lamp failure indications**