

WIRING INSTRUCTIONS

TITLE

TOP HANDLE JIG SAW

BULLETIN

58-01-1950

MILWAUKEE ELECTRIC TOOL CORP. 13135 WEST LISBON RD. BROOKFIELD,

DATE

June 2005

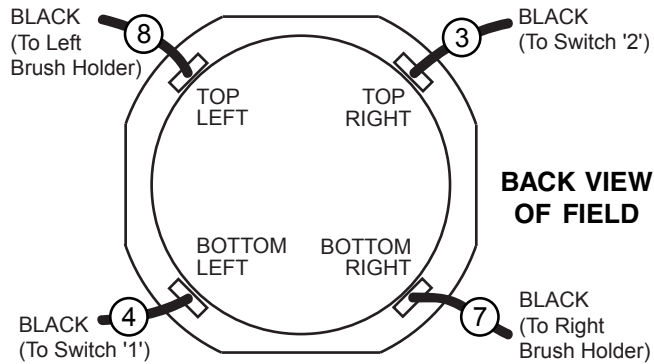
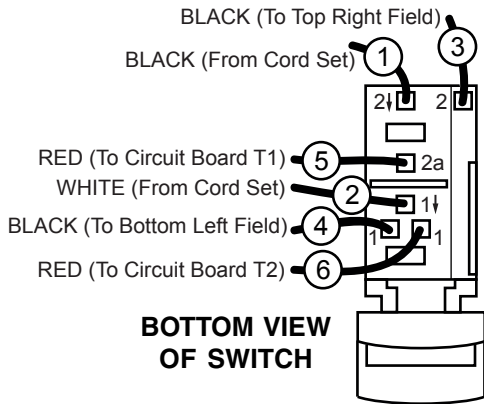

ROUTE GREY AND WHITE LED WIRES THROUGH TRAPS AS SHOWN.

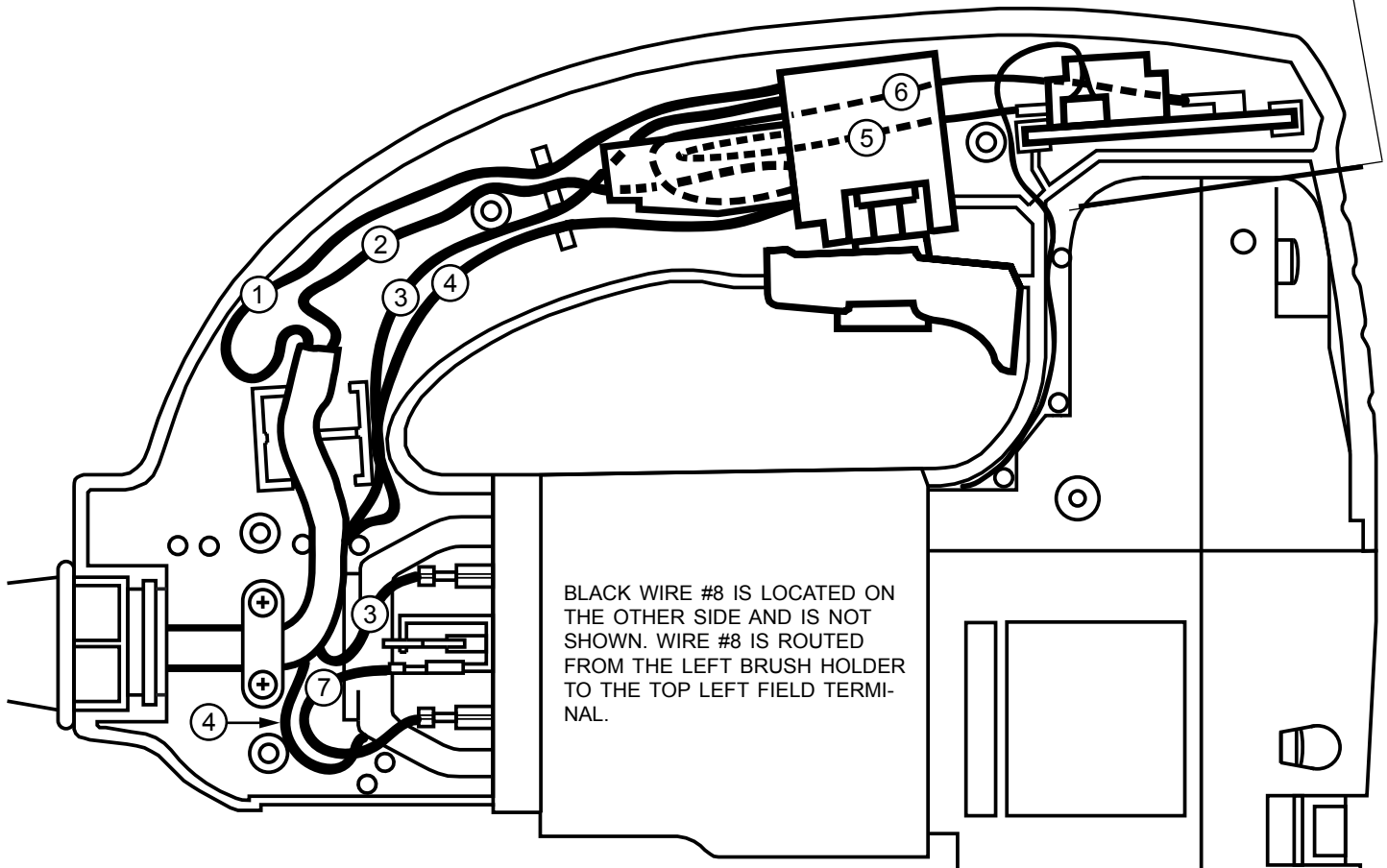

AS AN AID TO REASSEMBLY, TAKE NOTE OF WIRE ROUTING AND POSITION IN WIRE GUIDES AND TRAPS WHILE DISMANTLING TOOL.

WIRING SPECIFICATIONS

Wire No.	Wire Color	Origin or Gauge	Length	Terminals, Connectors and 1 or 2 End Wire Preparation
1	BLACK	--	6"	COMPONENT OF CORD SET.
2	WHITE	--	6"	COMPONENT OF CORD SET.
3	BLACK	--	9"	LEADWIRE ASSEMBLY 23-94-1155.
4	BLACK	--	9"	LEADWIRE ASSEMBLY 23-94-1155.
5	RED	--	5.25"	LEADWIRE ASSEMBLY 23-94-1045.
6	RED	--	5.25"	LEADWIRE ASSEMBLY 23-94-1045.
7	BLACK	--	1.75"	LEADWIRE ASSEMBLY 23-94-6640.
8	BLACK	--	1.75"	LEADWIRE ASSEMBLY 23-94-6640.

NOTE:

All leads must be held to $\pm .125"$.
All lead lengths are before stripping.

TERMINAL DESCRIPTION

Code	Part No.	Qty.

CONNECTOR DESCRIPTION

BULK LEAD WIRE - BULLETIN NO. 58-01-0003