



SelecTone® Standby Battery/Back-up Power Supplies

Models PS250, PS600 and PS1000

FOR PRIMARY AND EMERGENCY POWER

- Supplies 12VDC or 24VDC
- Integrated battery charger
- Choice of 7 or 12 amp-hour capacity
- Meets NFPA standards
- Type 1 enclosure
- UL Listed
- Batteries ordered separately

Federal Signal Power Supplies provide nominal 12VDC or 24VDC power that is switch selectable. The PS250, PS600 and PS1000 are designed for use as standby battery back-up during a power outage.

The steel enclosure is designed to mount on a wall or substantial vertical surface (indoor only). A key lock is provided to discourage unauthorized access – simple lock installation is required.

The power supply sub-assembly, which recharges the batteries, includes solid-state circuitry that provides DC operating voltage to units in a SelecTone® system, while maintaining a charge level on the batteries.

All of the units can also be used as a primary 12V or 24V power source for other devices/systems.

Model PS250

The Model PS250 – which is designed to use two 7 amp-hr, sealed lead-acid, gelled electrolyte batteries connected in series – is rated for 2.5 ampere, and is UL listed.

Model PS600

The Model PS600 – which is designed to use two 12 amp-hr, sealed lead-acid, gelled electrolyte batteries connected in series – is rated for 6 ampere, and is UL listed.

Model PS1000

The Model PS1000 – which is designed to use two 12 amp-hr, sealed lead-acid, gelled electrolyte batteries connected in series – is rated for 10 ampere, and is UL listed.

Model	Voltage	Output Current	Output Voltage
PS250	120/240VAC	2.50 amps	12/24VDC
PS600	120/240VAC	6.00 amps	12/24VDC
PS1000	120VAC	10 amps	24VDC



SELECTONE® BACK-UP POWER SUPPLIES (PS250 / PS600 / PS1000)

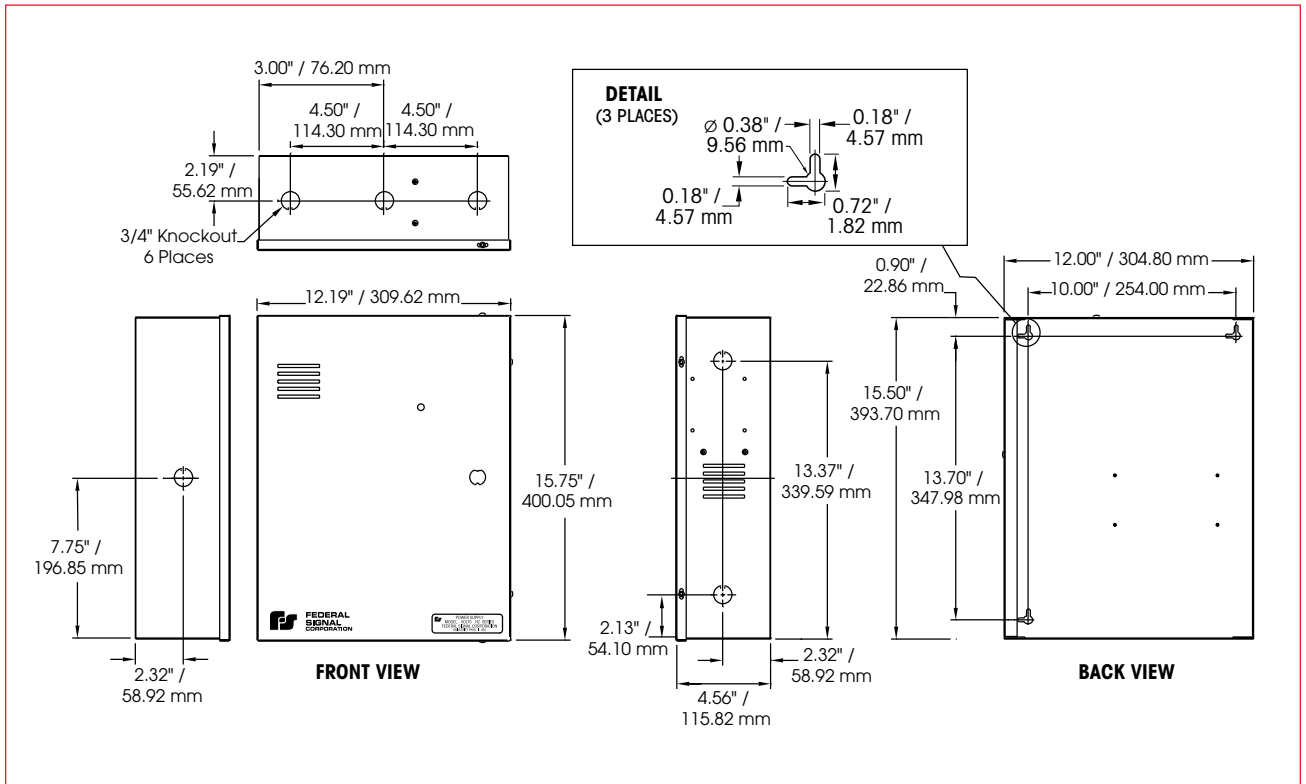

SPECIFICATIONS

Operating Temperature:	32°F to 120°F	0°C to 49°C
Net Weight:		
PS250	10.25 lbs.	4.65 kg
PS600	12.65 lbs.	5.74 kg
PS1000	12.65 lbs.	5.74 kg
Shipping Weight:		
PS250	12.1 lbs.	5.49 kg
PS600	14.5 lbs.	6.58 kg
PS1000	14.5 lbs.	6.58 kg
Height:	15.5"	394.0 mm
Width:	12.5"	318.0 mm
Depth:	4.5"	115.0 mm

HOW TO ORDER

- Specify model number

REPLACEMENT PARTS

<i>Description</i>	<i>Part Number</i>
12V, 7 Amp-Hr battery (Model PS250)*	K155189A
12V, 7 Amp-Hr battery (Model PS600 and 1000)*	K155190A

*Each model requires two batteries