

Hazardous Location Heaters

Thermostat

# INSTRUCTION MANUAL

# TABLE OF CONTENTS

Warranty and Return Policy .....	2
Application .....	3
Control Accuracy .....	3
Technical Data .....	3
Design Data .....	3
HLTSTAT Thermostat Nominal Setpoints .....	3
Explosion Protection .....	4
Installation Instructions .....	4
ROUTINE CHECK TESTS .....	5
Initial Operation .....	5
Wiring Diagram .....	7
Maintenance .....	7
CE Declaration of Conformity .....	8

**NOTE: Some of the information in this manual may not apply if a special unit was ordered. If additional drawings for a special unit are necessary, they have been inserted. Contact Pentair Equipment Protection if further information is required.**

## WARRANTY AND RETURN POLICY

<https://hoffman.nvent.com/en/hoffman/warranty-information>



## APPLICATION

When connected to an electric heater, the thermostat can regulate the temperature in a housing to the pre-set, nominal, setpoint; see HLTSTAT Thermostat Nominal Setpoints table below.

The thermostat closes the circuit when the temperature is below the setpoint and opens it when the temperature is above the setpoint.

## CONTROL ACCURACY

The air temperature in a heated housing is not the same everywhere. Depending on the difference between inside and outside temperature (delta T), insulation, configuration of the heater and the installed equipment etc., the temperature (e.g. between top and bottom) can fluctuate by 18 F [10 C] or more.

For exact temperature control of an instrument, a proportional controller with temperature sensor should be used.

## TECHNICAL DATA

### DESIGN DATA

	HLTSTAT10C, HLTSTAT20C
Rated voltage (VAC or VDC)	0 - 275V
Maximum Rated Current (Amps) (acc. to DIN VDE 0298)	10
Temperature Tolerance	+/- 5 F [3 C]
Temperature class	T6
Ambient temperature	-76 to +140 F (-60 to +60 C)
Maximum permissible operating temperature range at normal rating	-76 to +302 F (-60 to +150 C)
Connection cable	39 (1m) long silicone cable, notch and oil resistant, 3x AWG16; Ø 0.37 (9.4mm)
Conduit connection	½ NPT
Ingress Protection	IP66 / IP68 (1bar/30min)
Material	seawater-proof aluminium, black anodized
Length (in./mm)	3.5 (89)
Width (in./mm)	1.6 (41)
Depth (in./mm)	1.2 (30)
Weight (lb./g)	1.1 (28)

### HLTSTAT THERMOSTAT NOMINAL SETPOINTS

Type	Switch on	Switch off
HLTSTAT10C	50 F / 10 C	64 F / 18 C
HLTSTAT20C	68 F / 20 C	82 F / 28 C

## EXPLOSION PROTECTION

	<b>TAE</b>
Manufacturer	INTERTEC-Hess
CSA Certificate	1655545 (LR43674)
CSA Type of Protection	Cl. I, Grp. ABCD T6 Cl. II Grp. EFG
IEC Scheme Certificate	IECEx PTB 07.0054X
EC Type Examination Certificate	PTB 03 ATEX 1136 X
Marking	II 2 G Ex db IIC T6
	II 2 D Ex tb IIIC T80°C

### INSTALLATION INSTRUCTIONS

The thermostat must be attached to the face of the heater as noted. Pentair DAHHL finned heaters are equipped with slotted mounting rails in the fins. Slightly loosen the mounting bolt included in the thermostat.

Insert the head of the bolt into one of the slotted mounting rails of the finned profile. The PTFE spacer must remain outside, as this provides the right gap from the thermostat to the surface of the heater fins. Carefully tighten the bolt by turning the thermostat. **DO NOT OVERTIGHTEN.**

The thermostat is equipped with a ground terminal. Use a cable gland or a ½ NPT conduit depending on the application.

Be careful not to bend or exert any load on the connection cable during unpacking and transport.

Before entering the customer-supplied Ex junction box, the connection cable must be firmly installed and mechanically protected observing the permissible bending radius of 5 times the outside cable diameter.

If the connection is made in a hazardous area, the connection cable must be connected in a housing that meets the requirements of one of the types of ignition protection mentioned in EN 50014 Section 1.2.

When determining the operating temperature, the maximum permissible ambient temperature, self-heating and, possibly, heat transfer (medium) must be considered.

In dust hazardous areas, the applicable requirements of the EN 60079-14 have to be observed.

**CAUTION!** Remove the RED protection cap only for ½ NPT conduit installation. Never remove the adapter. See Figure 3 on page 6

The components must only be connected and secured by certified technical personnel in accordance with the label specifications rated voltage and rated current. Circuit breakers suitable for up to 16 A can be used for short circuit and line protection.

A ground terminal is provided for the purpose of ensuring potential equalization; see Figure 1 on page 5. The terminal is marked as such.

## ROUTINE CHECK TESTS

The following check tests have to be carried out on the installed heating system:

- Do a Visual inspection to determine if the conditions specified under Installation Instructions are met.
- Conduct an insulation test.

## INITIAL OPERATION

When the routine tests are successfully completed, the device can be switched on.

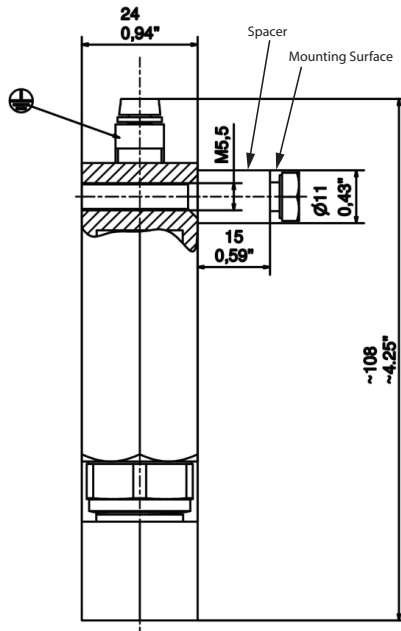

Figure 1

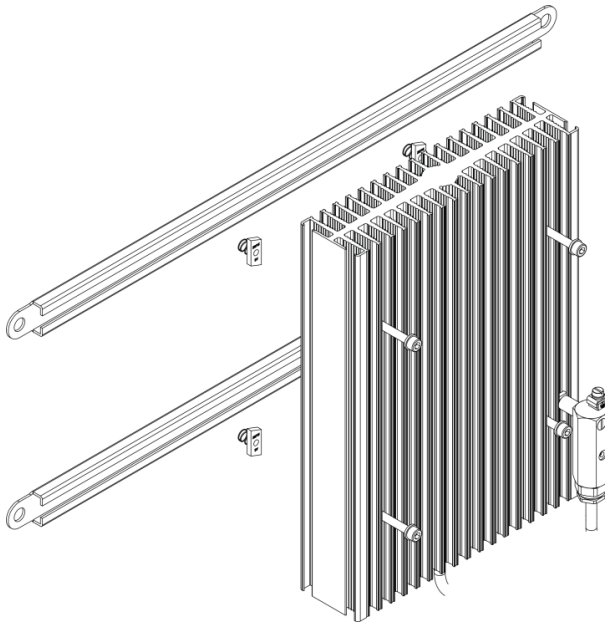

Figure 2

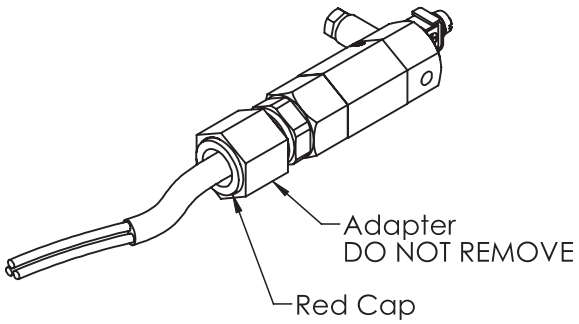

Figure 3

# WIRING DIAGRAM

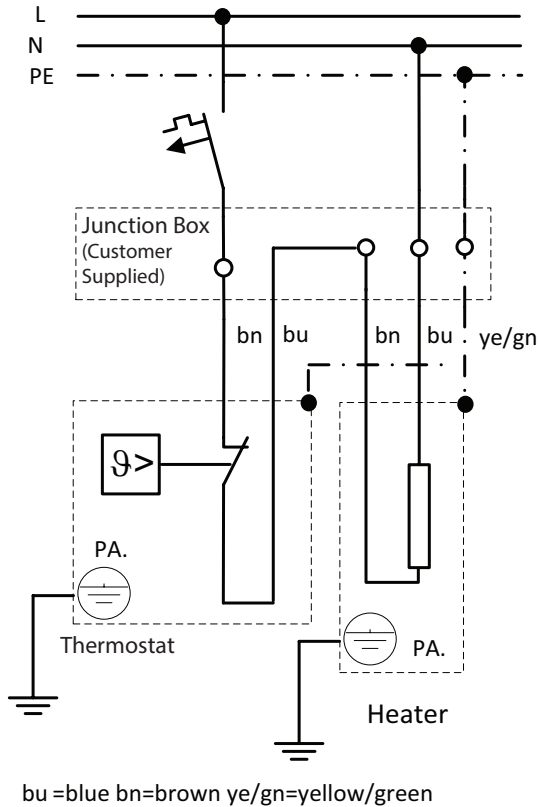

Figure 4

## MAINTENANCE

The thermostat is completely encapsulated in silicone, and requires no maintenance.

Performance and safety tests can be conducted at intervals as determined by the operator in compliance with current regulations.

Repairs must only be done by the manufacturer. In dust hazardous areas, applicable requirements of EN 60079-17 and EN 60079-19 must be observed.

# CE DECLARATION OF CONFORMITY

Erklärung der EG-Konformität  
Declaration of EC-Conformity  
Заявление о соответствии  
директивам ЕС



INTERTEC Hess GmbH  
Raffineriestraße 8  
93 333 Neustadt / Donau

Wir

We

Мы

**INTERTEC Hess GmbH,**

erklären in alleiniger  
Verantwortung, dass das Produkt

declare under our sole  
responsibility that the product

заявляем под свою  
исключительную  
ответственность, что продукция

**TA ...**

auf das sich diese Erklärung  
bezieht den Bestimmungen der  
folgenden Richtlinien entspricht

to which this declaration relates is  
in accordance with the provision of  
the following directives

на которую распространяется  
данное заявление, соответствует  
следующим директивам

**2014/34/EU (ATEX)  
2006/95/EG (LVD)  
2014/30/EU (EMC)  
2011/65/EU (RoHS)  
2012/19/EU (WEEE)**

**2014/34/EU (ATEX)  
2006/95/EC (LVD)  
2014/30/EU (EMC)  
2011/65/EU (RoHS)  
2012/19/EU (WEEE)**

**2014/34/EU (ATEX)  
2006/95/EC (LVD)  
2014/30/EU (EMC)  
2011/65/EU (RoHS)  
2012/19/EU (WEEE)**

und mit folgenden Normen oder  
normativen Dokumenten  
übereinstimmt

and is in conformity with the  
following standards or other  
normative documents

и соответствует следующим  
стандартам или другим норма-  
тивным документам

**EN IEC 60079-0:2012 EN IEC 60079-1:2007 EN IEC 60079-31:2014  
EN IEC 60529:1991+A1:2000+A2:2013 EN IEC 61000-6-4:2007+A1:2011**

Kennzeichnung

Marking

Маркировка

**CE** 0102

**Ex II 2 G Ex db IIC T6**

**Ex II 2 D Ex tb IIIC T80°C**

**Degree of protection IP66/ IP68 <sup>1bar/ 30min</sup>**

**PTB 03 ATEX 1136 X**

Neustadt, den 28.04.2016

Dipl.-Ing. Martin Hess  
Geschäftsführer

BINT040

INTERTEC-Hess GmbH · Raffineriestraße 8 · D-93333 Neustadt/Donau · Tel: +49 (0) 9445/95 32-0 · Fax: +49 (0)9445/95 32 32



# NOTES

# NOTES

# NOTES



**nVent**  
**2100 Hoffman Way**  
**Anoka, MN 55303 USA**  
**☎ +1.763.422.2211**  
**📠 +1.763.576.3200**

**nVent.com**