



# model 3202

## Barrier-Free Steel Pedestal Fountain

### FEATURES & BENEFITS

#### CONSTRUCTION

Heavy-duty 12 gauge galvanized steel with a green powder-coat finish incorporates a recessed push button and welded bubbler guard to provide extra durability, a large access panel for ease of service, and a vandal-resistant bottom plate for added peace of mind.

#### DRAIN FREE

Unique design allows this pedestal fountain to be placed in the harshest of outdoor environments without the worry of a clogged drain. When water is activated, the excess flow runs from its trough basin off the back and onto the ground - perfect for beaches, play grounds, and other areas high in debris.

#### BUBBLER HEAD

Polished chrome-plated brass bubbler head with integral basin shank for added strength. Shielded, angled stream opening provides a steady, sanitary source of drinking water at .45 gpm.

#### PUSH BUTTON VALVE

The push-button activated valve assembly allows for front access stream adjustment as well as cartridge and strainer access. The valve works at an operating pressure range of 30 to 90 psi (2.1 to 6.2 bar).

### OPTIONS

- ❑ Faucet Valve: Model 6250LF, self-closing, plain end, lead-free, brass bib faucet with polished chrome-plated finish. (When used with Haws concrete products, also order part 0004499489; for 3511, use 0004521763)

For more information, visit [www.hawsc.com](http://www.hawsc.com) or call (888) 640-4297.



### SPECIFICATIONS

Model 3202 barrier-free pedestal drinking fountain shall include a 12 gauge galvanized substrate steel pedestal with green powder coating, push-button operated stainless steel valve with front-accessible cartridge and flow adjustment, 100% lead-free waterways, polished chrome-plated brass vandal-resistant bubbler head backed against a pedestal guard, trough design in the pedestal instead of a waste to eliminate clogging, a 1/4" (.6 cm) spacer to raise the pedestal off the ground which reduces the potential for corrosion, integral mounting feet, and an over-size vandal-resistant access plate.

### APPLICATIONS

Perfect for either public or private settings, the trough style fountain is a great fit in areas more prone to drain clogging. Completely eliminating the need for a traditional fountain drain, trough fountains are a nice complement to outdoor environments where a gravel fill can be implemented. Heavy-duty steel and green powder-coated finish make for a solid freestanding design that will hold up and blend in with the environment. More specifically, this fountain is applicable in forest/campground environments as well as parks, schools, and other outdoor areas where drinking facilities are needed. Model meets all current Federal Regulations for the disabled including those in the Americans with Disabilities Act. Haws manufactures drinking fountains and electric water coolers to be lead-free by all known definitions including NSF/ANSI Standard 61, Section 9, NSF/ANSI 372, California Proposition 65, and the Federal Safe Drinking Water Act. Product is compliant to California Health and Safety Code 116875 (AB 1953-2006).



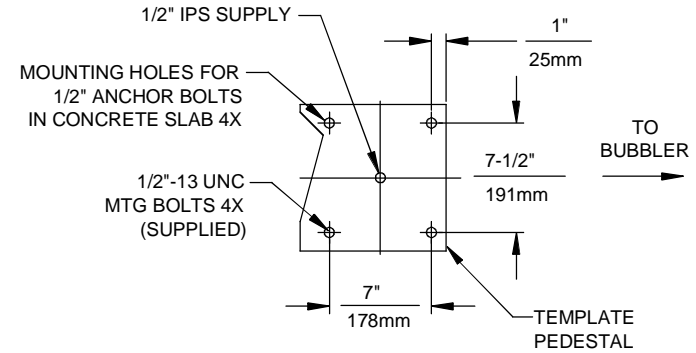
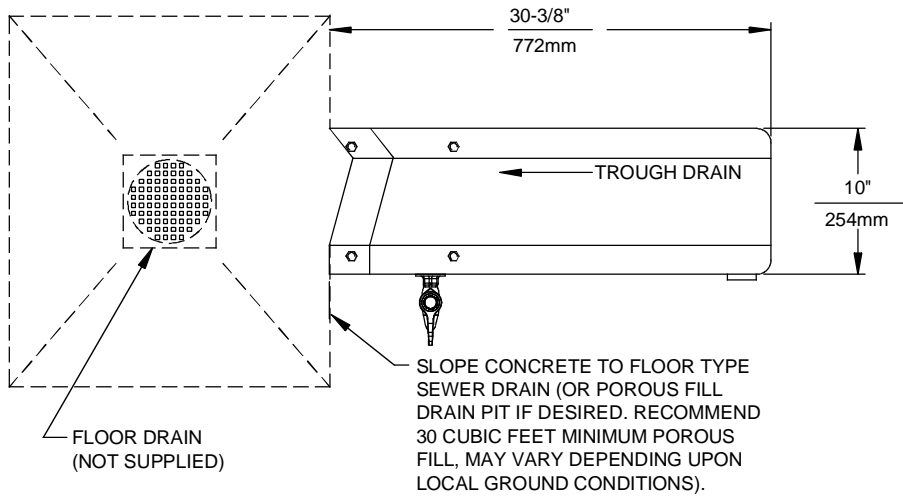

### MOUNTING DETAIL

### IMPORTANT: ATTENTION INSTALLER

USE CARE TO AVOID KINKS WHEN ROUTING SUPPLY LINE TO VALVE AND FROM VALVE TO BUBBLER

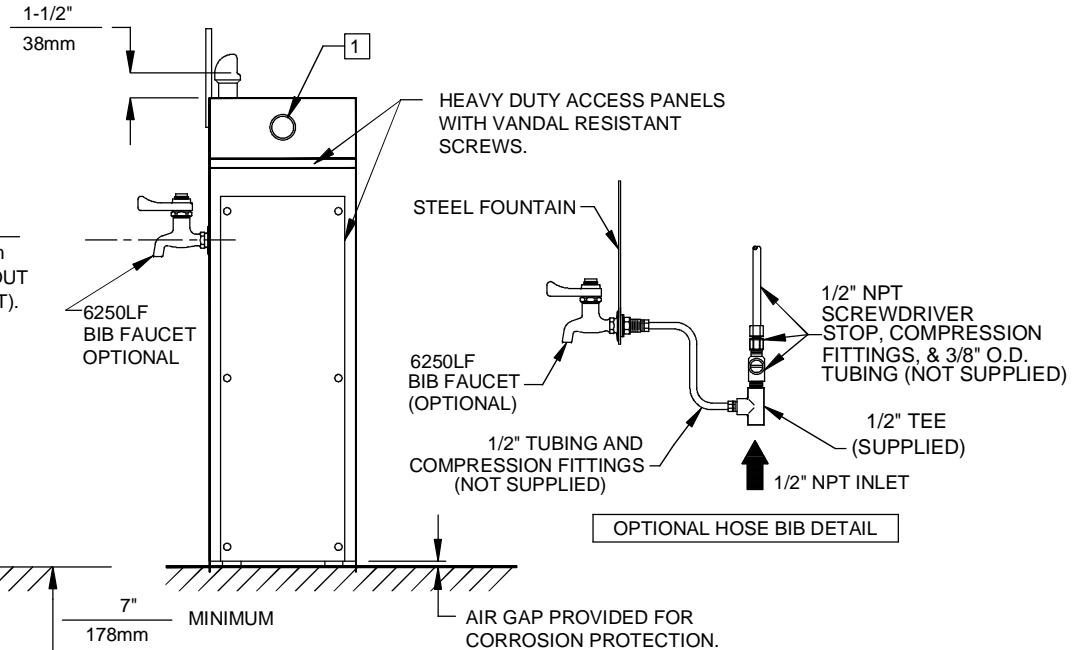
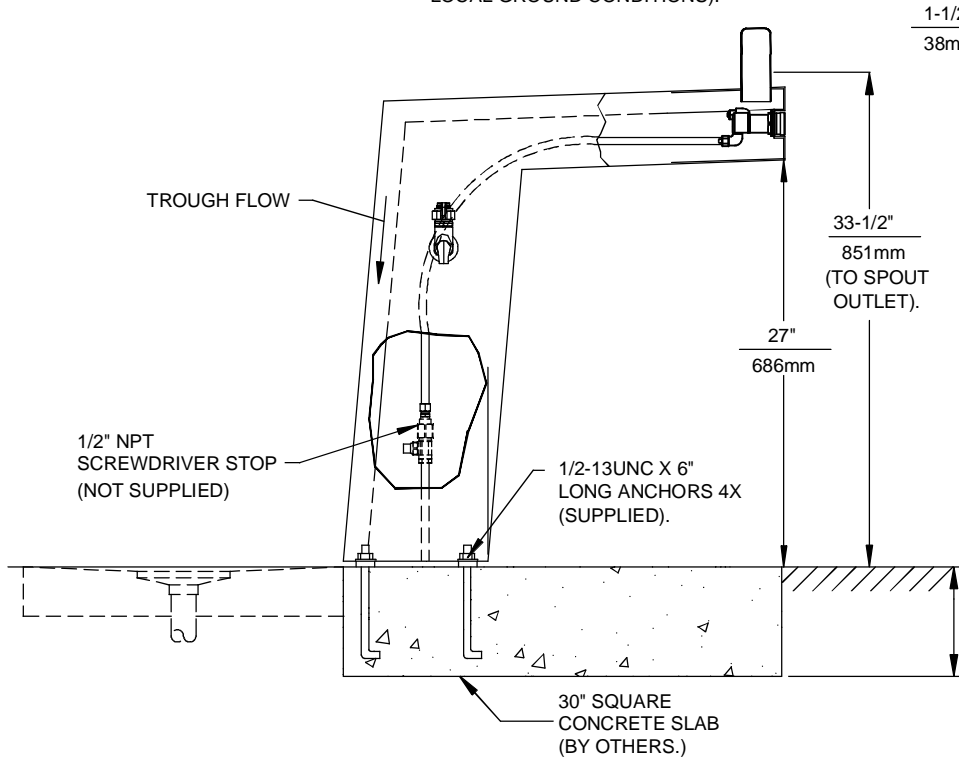

### NOTES:

- REFER TO 5874SS OPERATION AND MAINTENANCE MANUAL FOR PUSH BUTTON AND VALVE INSTALLATION/MAINTENANCE INSTRUCTIONS.

1455 KLEPPE LANE  
SPARKS, NEVADA 89431  
(775) 359-4712 FAX (755) 359-7424  
E-MAIL: HAWS@HAWS.CO.COM  
WEBSITE: WWW.HAWS.CO.COM

ECN NO. REVISED PER BY:	MODEL(S)	PART NUMBER	
ECN: 4828	HM	0002077328.D	
DRAWN: C. HAYES	DATE: 11/91	CHKD:	3202/3202G
APPROVED:	DATE:	DRAWING NO. 09912A00	REV 23
SCALE: 1:14		DRAWING TYPE: INSTALLATION	SIZE: A SHEET 1 OF 1