



# model 3060

## Pedestal Mount Concrete Drinking Fountain

### FEATURES & BENEFITS

#### CONSTRUCTION

Heavy-duty wire reinforced concrete construction with exposed aggregate finish provide a perfect addition to outside environments, along with a vandal-resistant access plate for added peace of mind. Stainless steel basin with a high-polished finish compliments almost any setting, and it also resists stains and corrosion.

#### BUBBLER HEAD

Polished chrome-plated brass bubbler head is equipped with a shielded, anti-squirt orifice that provides a steady sanitary source of water.

#### PUSH BUTTON VALVE

The push-button activated valve assembly allows for front access stream adjustment as well as cartridge and strainer access. The valve works at an operating pressure range of 30 to 90 psi (2.1 to 6.2 bar).



### OPTIONS

- ❑ Faucet Valve: Model 6250LF, self-closing, plain end, lead-free, brass bib faucet with polished chrome-plated finish. (When used with Haws concrete products, also order part 0004499489; for 3511, use 0004521763)
- ❑ Sand Trap: Model 6611, sand trap for installing adjacent to pedestal drinking fountains to help prevent debris and contaminants from clogging waste line.

For more information, visit [www.hawsc.com](http://www.hawsc.com) or call (888) 640-4297.

### SPECIFICATIONS

Model 3060 circular concrete pedestal drinking fountain shall include a polished stainless steel basin, push-button operated stainless steel valve with front-accessible cartridge and flow adjustment, polished chrome-plated brass vandal-resistant bubbler head protected by a hood extension, polished chrome-plated vandal-resistant waste strainer, Portland Gray exposed aggregate concrete finish with wire reinforcement, integral mounting feet, vandal-resistant stainless steel access plate, and 1-1/4" O.D. tailpiece.

### APPLICATIONS

Perfect for either public or private settings, our concrete series is a great fit in "open-air" environments. Suitable in areas where weather conditions may be cause for concern, this series stands strong from the forest to the beach. Wire reinforced concrete design not only protects from corrosion, its Portland Gray color makes it recognizable enough to locate without compromising the outdoor atmosphere. This type of pedestal drinking fountain may also be placed in a variety of settings such as: parks, schools, and other recreational outdoor environments where the temperature remains above freezing. Haws manufactures drinking fountains and electric water coolers to be lead-free by all known definitions including NSF/ANSI Standard 61, Section 9, NSF/ANSI 372, California Proposition 65, and the Federal Safe Drinking Water Act. Product is compliant to California Health and Safety Code 116875 (AB 1953-2006).



THIS DOCUMENT IS TRUE AND CORRECT AT TIME OF PUBLICATION. CONTINUED PRODUCT IMPROVEMENTS MAKE SPECIFICATIONS AND MEASUREMENTS SUBJECT TO CHANGE WITHOUT NOTICE.

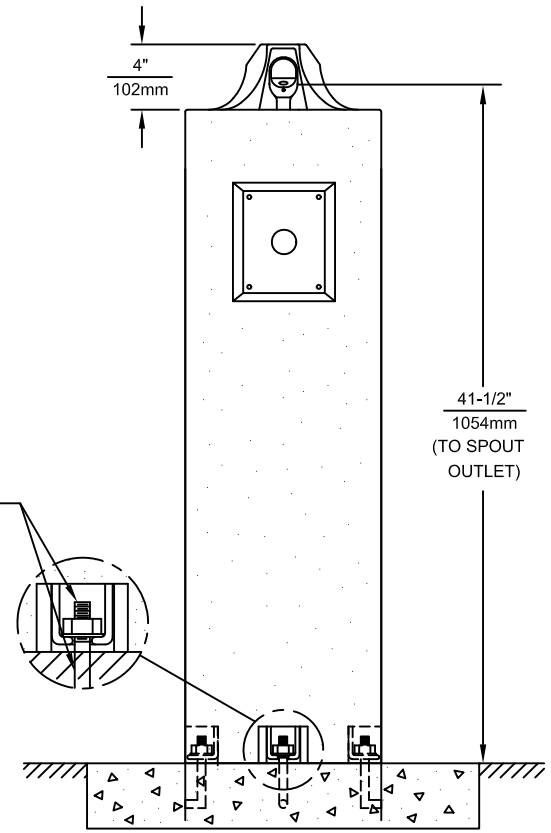
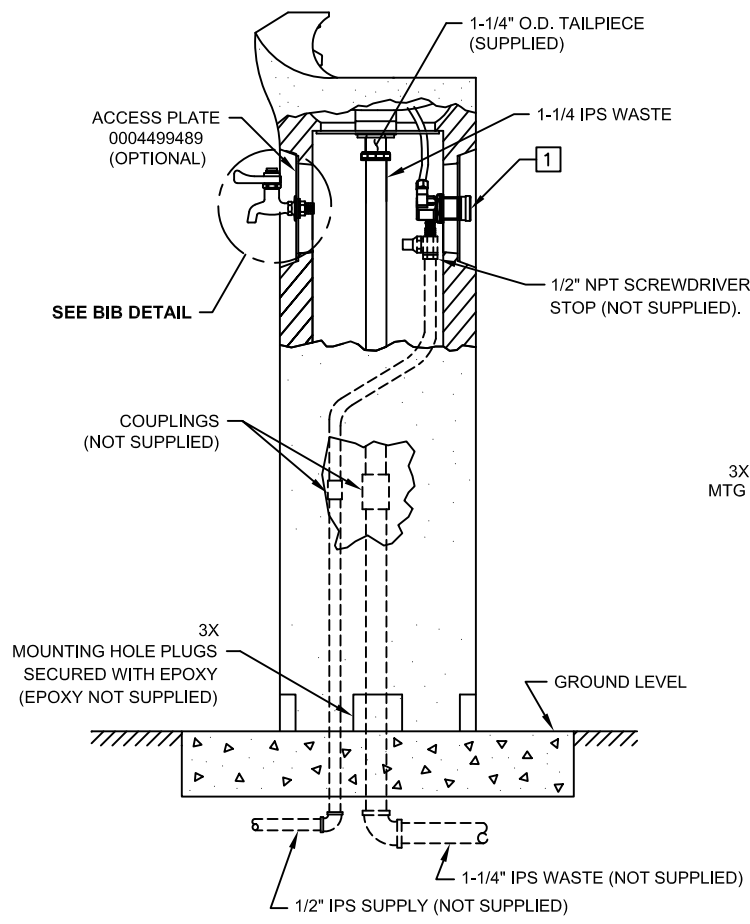
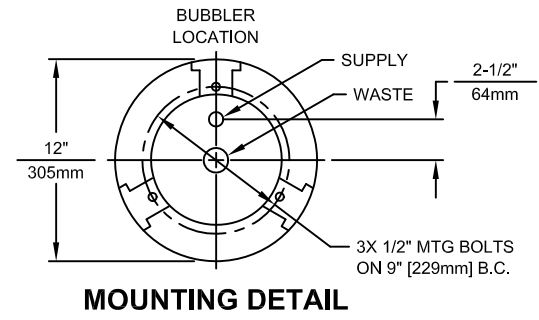
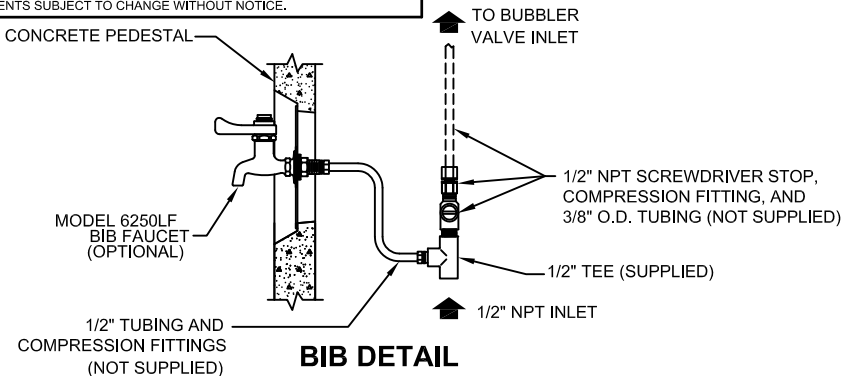

**NOTES:**

1 REFER TO 5874SS OPERATION AND MAINTENANCE MANUAL FOR PUSH BUTTON AND VALVE INSTALLATION/MAINTENANCE INSTRUCTIONS.

		1455 KLEPPE LANE SPARKS, NEVADA 89431 (775) 359-4712 FAX (775) 359-7424 E-MAIL: HAWS@HAWSCO.COM WEBSITE: WWW.HAWSCO.COM	
		ECN NO. REVISED PER BY: ECN:4646 HM	MODEL(S)
DRAWN: RF	DATE: 08/90	CHKD.:	3060
APPROVED:	DATE:	SCALE: 1:12	DRAWING TYPE: INSTALLATION
		SIZE: A	SHEET 1 OF 1
		DRAWING NO. 08935A00	REV 16