

ITEM	DESCRIPTION	PART NO.
1	STRAINER WASTE ASSY, PCP	6461
2	BUBBLER HEAD ASSY, PCP	5701SL
3	BUTTON, PUSH, NON-FLANGED, PCP	5874PB
4	VALVE REPAIR KIT	VRK5874
5	PUSH BUTTON ASSY	PBA7
6	VALVE, BIB FAUCET, PCP	6250LF
7	PLATE, ACCESS, 3060, W/ HOLE	0004499489

* DENOTES OPTIONAL PART.

NOTES:

- 1 5874PB (ITEM 3) INCLUDES VRK5874 CARTRIDGE ASSEMBLY (ITEM 4) AND PBA7 RECESSED PUSH BUTTON (ITEM 5).
- 2 USE MODEL 6250LF WITH ACCESS PLATE, PN 0004499469.
- 3 ENSURE TUBE IS DISCONNECTED FROM PUSH BUTTON VALVE BODY PRIOR TO REMOVAL. APPLY ONE DROP OF LOCTITE 222MS TO NOZZLE THREADS PRIOR TO FASTENING BACK ONTO BUBBLER HEAD. RE-ATTACH TUBE TO VALVE.

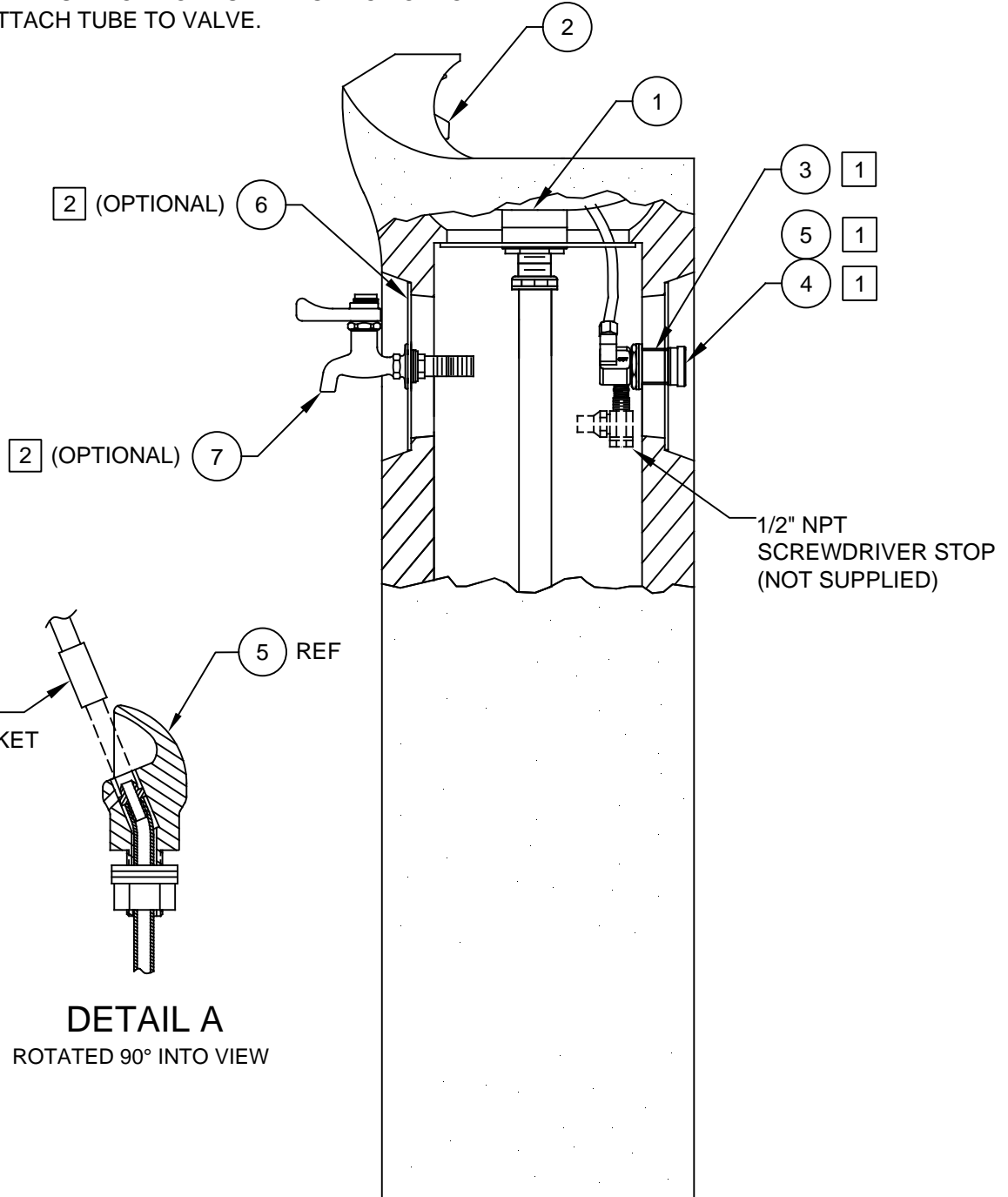

3 REMOVE INSERT WITH 5/16 HEX SOCKET (NOT SUPPLIED)

DETAIL A
ROTATED 90° INTO VIEW

PARTS BREAKDOWN

		1455 KLEPPE LANE SPARKS, NEVADA 89431 (775) 359-4712 FAX (775) 359-7424 E-MAIL: HAWS@HAWSCO.COM WEBSITE: WWW.HAWSCO.COM	
ECN NO.	REVISED PER	BY	MODEL(S)
	ECN: 5187	VWC	3060
DRAWN	DATE	CHKD	PART NUMBER
D> OLLOM	11/25/95	VWC	0002077030
APPROVED	DATE		REVISION
FV	07/06/17		17
WHEN ORDERING PARTS PLEASE SPECIFY MODEL NUMBER.		SCALE: 1:6	DRAWING TYPE: PARTS BREAKDOWN
		SIZE: A	SHEET 1 OF 1