

8501/8503* 1/4"-3"

Bronze Ball Valve
Two Piece
Standard Port (1" - 3") Full Port (1/4" - 3/4")
600 WOG/150 SWP (1)
Threaded Ends
Blow-Out Proof Stem
MSS SP-110

*Not intended for use in potable water.

MATERIALS LIST

ITEM	PART	MATERIALS	ASTM SPEC.
1	Body	Cast Bronze	B584
2	Tailpiece	Brass	B283
		Cast Bronze (1 1/4" & up)	B584
3	Ball	Brass w/Hard Chrome Plating	B16
		316 Stainless Steel (2)	A276
4	Seat	RPTFE, 15% Glass Filled	
5	Stem	Brass	B16
		316 Stainless Steel (2)	A276
6	Thrust Washer	RPTFE, 25% Glass Filled	
7	Packing	PTFE	
8	Packing Nut	Brass	B16
9	Handle	Steel w/Zinc Plating	Commercial
10	Hand Grip	Vinyl	
11	Handle Nut	Steel w/Zinc Plating	Commercial

- (1) Hammond Valve recommends the use of Stainless steel ball and stem for steam applications. Please consult factory for more information.
 (2) Stem is stainless for 8503 and 2-1/2"-3" 8501

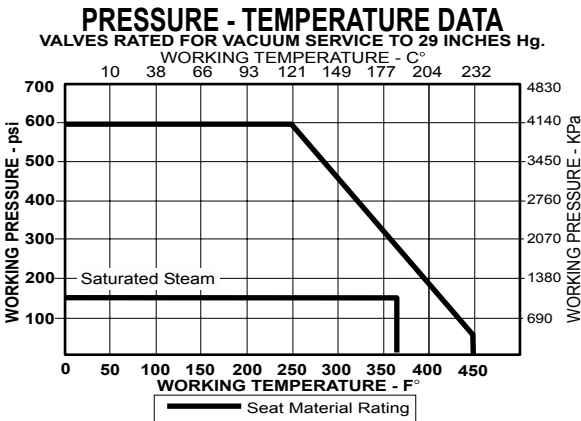
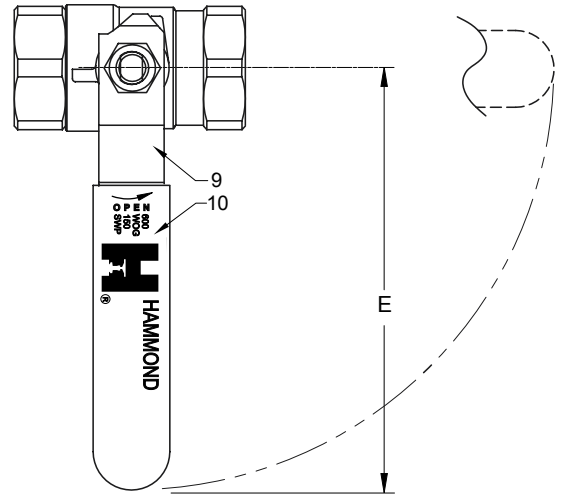
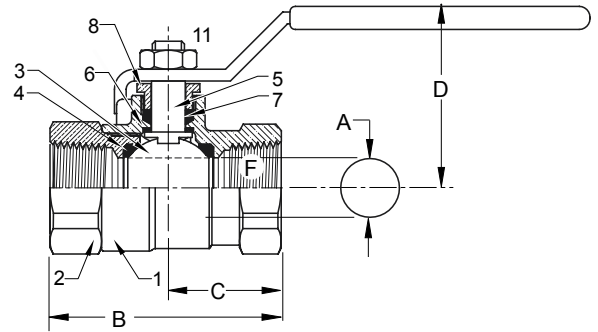

DIMENSIONS

	UNITS	1/4" DN6	3/8" DN10	1/2" DN15	3/4" DN20	1" DN25	1-1/4" DN32	1-1/2" DN40	2" DN50	2-1/2" DN65	3" DN80
A (DIA)	INCHES	0.38	0.38	0.50	0.76	0.88	1.06	1.31	1.56	2.00	2.31
	mm	10	10	13	19	22	27	33	40	51	59
B	INCHES	1.86	1.86	2.19	2.64	3.17	3.50	3.96	4.30	5.56	6.20
	mm	46	46	54	65	78	86	97	105	136	152
C	INCHES	1.00	1.00	1.10	1.30	1.58	1.74	1.97	2.15	2.79	3.10
	mm	25	25	27	32	39	43	48	53	68	76
D	INCHES	1.78	1.81	1.91	2.08	2.25	2.66	2.84	3.00	3.47	3.90
	mm	44	44	47	51	55	65	70	74	85	96
E	INCHES	3.81	3.81	3.81	4.56	4.56	6.31	6.31	7.19	7.19	7.19
	mm	93	93	93	112	112	155	155	176	176	176
F	THREAD SIZE	1/4" NPT	3/8" NPT	1/2" NPT	3/4" NPT	1" NPT	1-1/4" NPT	1-1/2" NPT	2" NPT	2-1/2" NPT	3" NPT
Cv		7	7	13	30	38	61	87	121	228	305

Note: DN (Diameter Nominal) = Metric equivalent size.

The information presented on this sheet is correct at the time of publication. Hammond Valve reserves the right to change design, and/or material specifications without notice. For the Installation, Operation and Maintenance Manual (IOM) see the Technical/Service Information section on our website. For the most current information access www.hammondvalve.com
 Hammond Valve is a registered trademark of Milwaukee Valve Company



HAMMONDVALVE