

# IB904/IB940 1/4"-3"

**Bronze Check Valve**  
**125 SWP - 200 WOG †**  
**Horizontal Swing • Threaded Ends**  
**Conforms to: MSS SP-80**

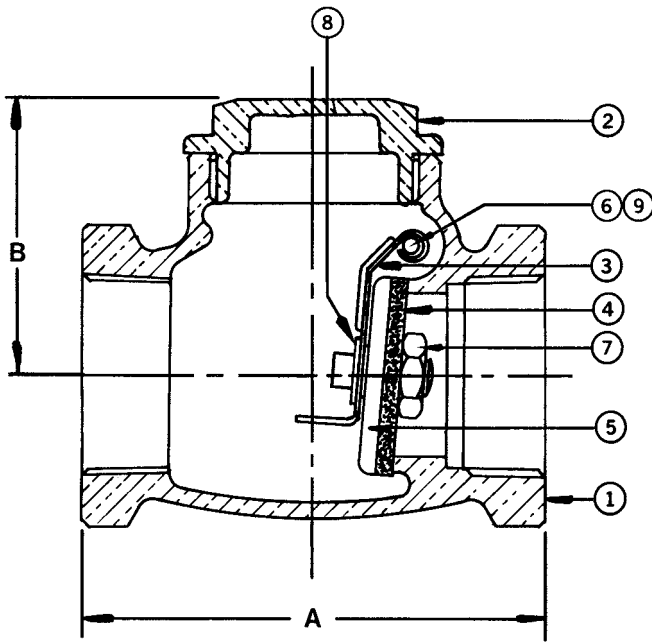

DIMENSIONS - INCHES/MILLIMETERS				
Units	Size	A	B	C <sub>v</sub>
Inches mm	1/4	2.13 54	1.32 34	3.3
Inches mm	3/8	2.13 54	1.32 34	6.0
Inches mm	1/2	2.31 59	1.32 34	10.0
Inches mm	3/4	2.63 67	1.69 43	18.0
Inches mm	1	3.25 83	2.00 51	31.0
Inches mm	1 1/4	3.56 91	2.13 54	54.0
Inches mm	1 1/2	4.00 102	2.38 60	76.0
Inches mm	2	4.75 121	2.81 71	131.0
Inches mm	*2 1/2	6.00 152	3.63 92	233.8
Inches mm	*3	6.88 175	4.19 106	286.4

† Non-Shock

\*2 1/2" and 3" not available in the IB940.

MATERIAL LIST			
No.	PART	MATERIAL	SPECIFICATION
1	Body	Bronze	ASTM B62
2	Cap	Bronze	ASTM B62
3	Lever	St. Steel-IB904	Commercial 1/4" to 2"
		Bronze-IB904	ASTM B584 2 1/2" and 3"
		Brass-IB940	ASTM B16 1/4" to 2"
4	Disc	Brass-IB904	ASTM B16 1/4" to 3/4"
			ASTM B453 1" to 1 1/2"
		Bronze-IB904	ASTM B62 2" to 3"
5	Disc Holder (509T Only)	Brass	ASTM B16 1/4" to 3/4"
		Bronze	ASTM B62 1" to 2"
6	Pin	St. Steel	Commercial
7	Disc Nut	Brass	ASTM B16
8	Retaining Ring	St. Steel	Commercial
9	Plug (not shown)	Brass	ASTM B16
10	Washer (not shown)	Brass	ASTM B16

Note: Not intended for use in potable water.

The information presented on this sheet is correct at time of publication. Hammond Valve reserves the right to change design and/or materials without notice. For our Installation, Operation and Maintenance Manual and the most current product information go to [www.hammondvalve.com](http://www.hammondvalve.com). Hammond Valve is a registered trademark of Milwaukee Valve.

⚠ State of California Prop 65 **WARNING: Cancer and Reproductive Harm.** For more information visit [www.p65warnings.ca.gov](http://www.p65warnings.ca.gov).