

IB652 1/4"-2"

**Bronze Gate Valve
300 SWP - 1000 WOG †
Solid Wedge Disc • Rising Stem
Union Bonnet • Threaded Ends • Cu-Ni Seat
Conforms to: MSS SP-80**

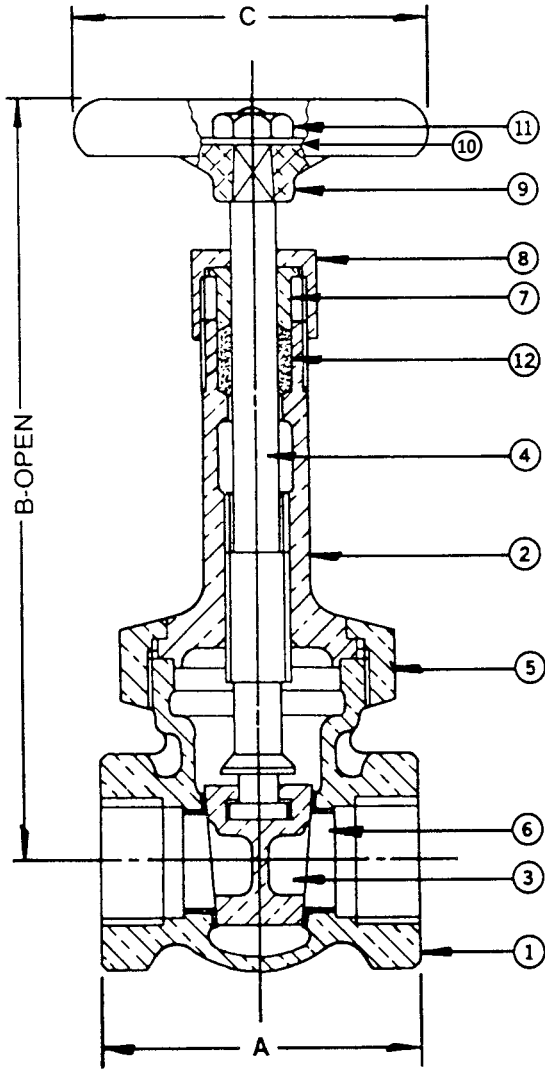

Note: Not intended for use in potable water.

MATERIAL LIST			
No.	PART	MATERIAL	SPECIFICATION
1	Body	Bronze	ASTM B61
2	Bonnet	Bronze	ASTM B61
3	Wedge Disc	Bronze	ASTM B61
4	Stem	Bronze	ASTM B61
5	Union Bonnet Nut	Bronze	ASTM B61
6	Seat Ring	Cu-Ni	90-10
7	Gland	Brass	ASTM B 124 C37700
8	Packing Nut	Brass	ASTM B 283 C37700
9	Handwheel	Mall. Iron	Commercial
10	Name Plate	Aluminum	Commercial
11	Handwheel Nut	Brass	Commercial
12	Packing	Graphite	Commercial

DIMENSIONS - INCHES/MILLIMETERS					
Units	Size	A	B	C	C _v
Inches mm	1/4	1.81 46	5.13 130	2.25 57	5.6
Inches mm	3/8	1.88 48	5.13 130	2.25 57	10.7
Inches mm	1/2	2.25 57	5.50 140	2.50 64	17.6
Inches mm	3/4	2.50 64	6.25 159	2.75 70	32.0
Inches mm	1	3.00 76	7.19 183	2.75 70	54.0
Inches mm	1 1/4	3.38 86	8.56 218	3.25 83	97.0
Inches mm	1 1/2	3.50 89	9.63 245	3.75 95	135.0
Inches mm	2	3.75 95	11.75 299	4.25 108	230.0

† Non-Shock

The information presented on this sheet is correct at the time of publication. Hammond Valve reserves the right to change design, and/or material specifications without notice. For the Installation, Operation and Maintenance Manual (IOM) see the Technical/Service Information section on our website. For the most current information access www.hammondvalve.com Hammond Valve is a registered trade mark of Milwaukee Valve Company.