

IB648 3/8"-3"

**Bronze Gate Valve
150 SWP - 300 WOG †
Solid Wedge Disc • Rising Stem
Union Bonnet • Solder Ends
Conforms to: MSS SP-80**

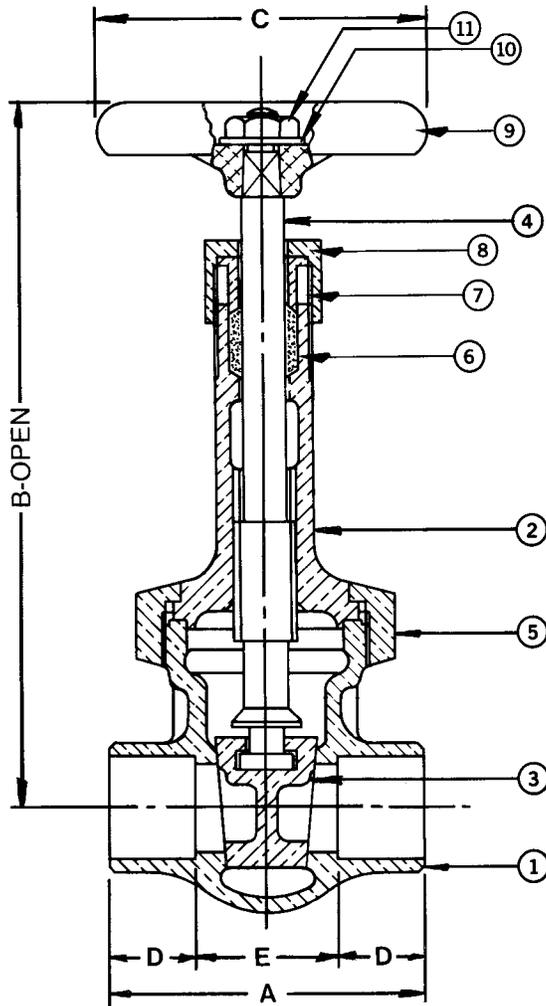

Note: Not intended for use in potable water.

MATERIAL LIST			
No.	PART	MATERIAL	SPECIFICATION
1	Body	Bronze	ASTM B62
2	Bonnet	Bronze	ASTM B62
3	Wedge Disc	Bronze	ASTM B62
4	Stem	Bronze	ASTM B62
5	Union Bonnet Nut	Bronze	ASTM B62
6	Packing	Graphite	Commercial
7	Gland	Brass	ASTM B124 C37700
8	Packing Nut	Brass	ASTM B283 C37700
9	Handwheel	Mall. Iron	Commercial
10	Name Plate	Aluminum	Commercial
11	Handwheel Nut	Brass	Commercial

DIMENSIONS - INCHES/MILLIMETERS							
Units	Size	A	B	C	D	E	C _v
Inches mm	3/8	1.63 41	5.13 130	2.00 51	.38 10	.88 22	5.6
Inches mm	1/2	2.13 54	5.50 140	2.50 64	0.50 13	1.13 29	10.7
Inches mm	3/4	2.63 67	6.25 159	2.75 70	0.75 19	1.13 29	17.6
Inches mm	1	3.00 76	7.19 183	2.75 70	0.91 23	1.19 30	32.0
Inches mm	1 1/4	3.38 86	8.56 218	3.13 80	0.97 25	1.44 37	54.0
Inches mm	1 1/2	3.75 95	9.63 245	3.50 89	1.09 28	1.56 40	97.0
Inches mm	2	4.31 110	11.75 299	4.00 102	1.34 34	1.63 41	135.0
Inches mm	2 1/2	5.25 133	14.25 362	4.75 121	1.47 37	2.31 59	230.0
Inches mm	3	5.75 133	16.50 419	5.25 133	1.66 42	2.44 62	337.0

† Non-Shock

The information presented on this sheet is correct at the time of publication. Hammond Valve reserves the right to change design, and/or material specifications without notice. For the Installation, Operation and Maintenance Manual (IOM) see the Technical/Service Information section on our website. For the most current information access www.hammondvalve.com Hammond Valve is a registered trade mark of Milwaukee Valve Company.