

Standard Construction Features

Belt Type: Synchronous
 Core Material: Oil & Heat Resistant (chloroprene)
 Cord/Tensile: Fiberglass
 Jacket: Nylon

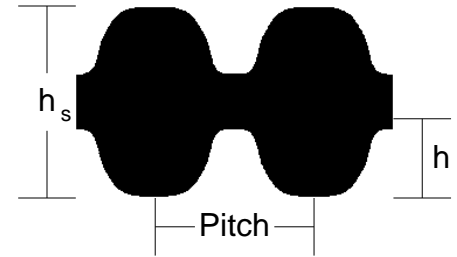

Belt Section Dimensions

Tooth Type	Pitch (mm)	h_s (mm)	h_t (mm)
GT	14.000	15.000	6.190

Belt Dimensions

Pitch Length (mm)	No. Teeth	Width (mm)
3850.00 + 1.320 - 1.320	275	85.000 + 0.000 - 0.000

Measuring Information

Y (mm)	T (N)	No. Teeth	O.D. (mm)	Pitch Circum. (mm)	Radial Runout (mm)	Axial Runout (mm)	PLD 2a (mm)
1757.00 + 0.660 + 0.660	0	24	104.16	336.00	0.0005	0.0030	2.794

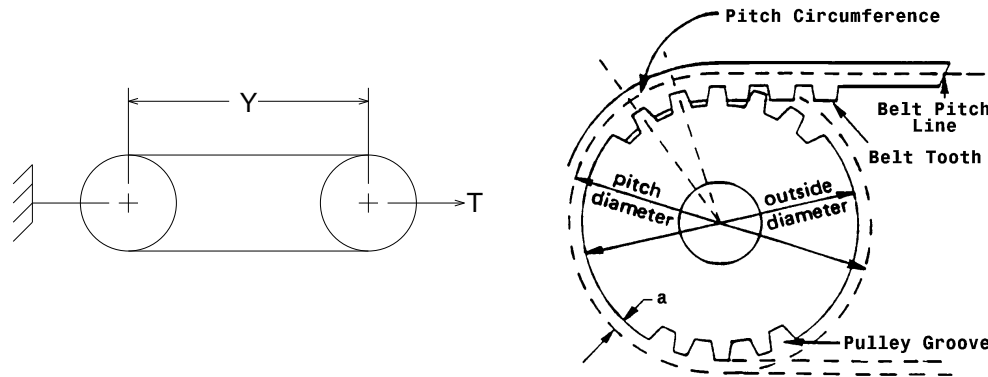

DesignView™ Belt Information Sheet

Created 28 Jun 2017 by Gates

Created for

PowerGrip Twin Power - 14MGT2

Gates Product Number

9232-0167

Customer Part Number

TP3850-14MGT-85

The length shall be measured by placing the belts on two pulleys of equal diameters that have been grooved in accordance with standard specifications and rotated at least three complete turns with the specified tension so that each strand receives half the total tension. The length will be that length obtained by adding the Pitch Circumference of one pulley to twice the center distance (dimension 'Y').