



Model LP3G Wire Guard for the Models LP3M, LP3S, and LP3T StreamLine® Strobe Light



Installation Instructions



Warranty – Seller warrants all goods for five years on parts and 2-1/2 years on labor, under the following conditions and exceptions: Seller warrants that all goods of Seller's manufacture will conform to any descriptions thereof for specifications which are expressly made a part of this sales contract and at the time of sale by Seller such goods shall be commercially free from defects in material or workmanship. Seller reserves the right at the Seller's discretion to "Repair and Return" or "Replace" any item deemed defective during the warranty period. This warranty does not cover travel expenses, the cost of specialized equipment for gaining access to the product, or labor charges for removal and reinstallation of the product. This warranty shall be ineffective and shall not apply to goods that have been subjected to misuse, neglect, accident, damage, improper maintenance, or to goods altered or repaired by anyone other than Seller or its authorized representative, or if five years have elapsed from the date of shipment of the goods by Seller with the following exceptions: lamps and strobe tubes are not covered under this warranty. Outdoor warning sirens and controllers manufactured by Federal Warning Systems are warranted for two years on parts and one year on labor. No agent, employee, representative or distributor of Seller has any authority to bind the Seller to any representation, affirmation, or warranty concerning the goods and any such representation, affirmation or warranty shall not be deemed to have become a part of the basics of the sales contract and shall be unenforceable. THE FOREGOING WARRANTIES ARE EXCLUSIVE AND IN LIEU OF ALL OTHER WARRANTIES OR MERCHANTABILITY, FITNESS FOR PURPOSE AND OF ANY OTHER TYPE, WHETHER EXPRESS OR IMPLIED. These warranties shall not apply unless Seller shall be given reasonable opportunity to investigate all claims for allegedly defective goods. Upon Seller's instruction a sample only of allegedly defective goods shall be returned to Seller for its inspection and approval. The basis of all claims for alleged defects in the goods not discoverable upon reasonable inspection thereof pursuant to paragraph 8 hereof must be fully explained in writing and received by Seller within thirty days after Buyer learns of the defect or such claim shall be deemed waived.

Industrial Systems

2645 Federal Signal Drive • University Park, IL 60484-3167

Tel: 708-534-4756 • Fax: 708-534-4852

Email: elp@federalsignal.com • www.federalsignal-indust.com

Contents

Installing the Wire Guard	1
With the Models LP3M and LP3S Strobe Light	1
With the Model LP3T Strobe Light.....	2
Obtaining Service, Assistance, and Parts.....	7
Returning the Product for Credit.....	8

Figures

Figure 1 LP3M, LP3S, and LP3T mounting dimensions.....	3
Figure 2 LP3M surface-mounted with wire guard	4
Figure 3 LP3S surface-mounted with wire guard.....	5
Figure 4 LP3T surface-mounted with wire guard.....	6

NOTICE

IMPORTANT: The LP3G wire guard is not for use with the Models LP3E and LP3P strobe light.

Installing the Wire Guard

The Model LP3G Wire Guard is used with the Models LP3M, LP3S, LP3T surface mounted strobe lights. These instructions supplement, and do not replace, the installation instructions for each of these models. Before installing the wire guard, follow the installation instructions included with the strobe light. Installer-supplied #10 (5 mm) screws of the appropriate length are required to mount the wire guard.

With the Models LP3M and LP3S Strobe Light

The wire guard for Models LP3M and LP3S includes two rubber washers (Figure 2 on page 4 and Figure 3 on page 5). For instructions on mounting and wiring the strobe light, see doc. No. 2561531 (LP3M) or doc. No. 2561456 (LP3S and LP3T).

To install the wire guard over the light:

1. If the strobe light is already installed, remove the light to avoid damaging it when drilling holes for the wire guard.
2. To mark the locations of the mounting holes, use the wire guard as a template or use the dimensions shown in Figure 1 on page 3.
3. Drill or punch out the holes marked on the mounting surface.
4. Mount the strobe light according the instructions included with it (doc. No. 2561531 or 2561456).
5. Center a rubber washer, included with the wire guard, on each mounting hole (Figures 1 and 2).
6. If wires are routed through the side of the strobe light, route them through the wire guard.
7. Place the wire guard on the rubber washers and align the mounting holes.
8. Secure the wire guard to the mounting location with user-supplied #10 (5 mm) screws of the appropriate length.
9. Complete the wiring according to the instructions included with the LP3M or LP3S strobe light.

With the Model LP3T Strobe Light

The base of the Model LP3T strobe light has two tabs with mounting holes that align with the mounting holes on the wire guard (Figure 4 on page 6). For instructions on mounting and wiring the strobe light, see doc. No. 2561456.

To mount the wire guard over the light:

1. If the strobe light is already installed, remove the two #10 screws securing it to the mounting surface.
2. If wires are routed through the side of the strobe light, route them through the wire guard.
3. Place the wire guard over the strobe light and align the holes in the tabs on the guard with the holes on the base of the light.
4. Secure the entire assembly to the mounting surface with user-supplied #10 (5 mm) screws of the appropriate length.

To mount the light in addition to the wire guard:

1. To mark the locations of the two 0.203" (5.15 mm) mounting holes, use the mounting gasket provided with LP3T as a template or the dimensions in Figure 1 on page 3.
2. Drill or punch out the holes marked on the mounting surface.
3. Mount the strobe light according the instructions included with it (doc. No. 2561456).
4. If wires are routed through the side of the strobe light, route them through the wire guard.
5. Place the wire guard over the strobe light and align the holes in the tabs on the guard with the holes on the base of the light.
6. Secure the entire assembly to the mounting surface with user-supplied #10 (5 mm) screws of the appropriate length.
7. Complete the wiring according to the instructions included with the LP3T strobe light.

Figure 1 LP3M, LP3S, and LP3T mounting dimensions

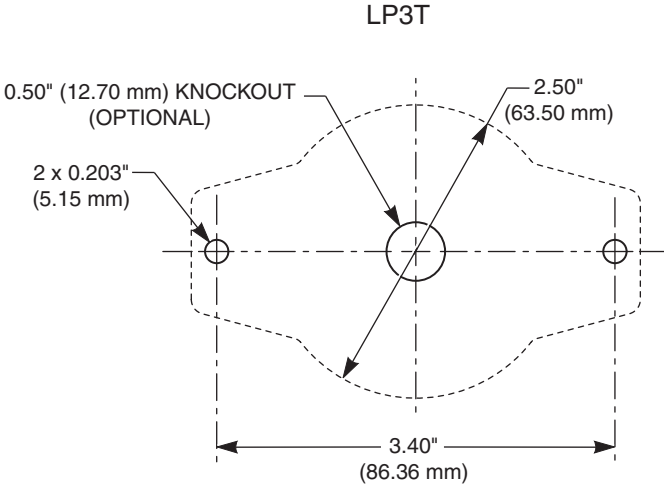
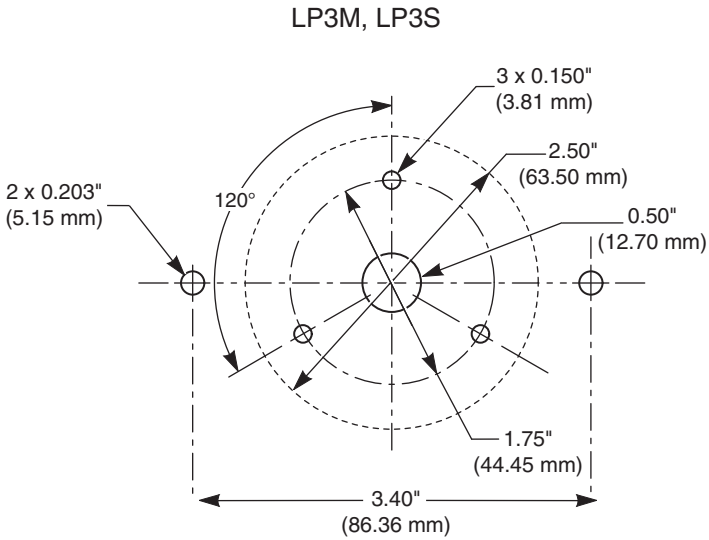

Figure 2 LP3M surface-mounted with wire guard

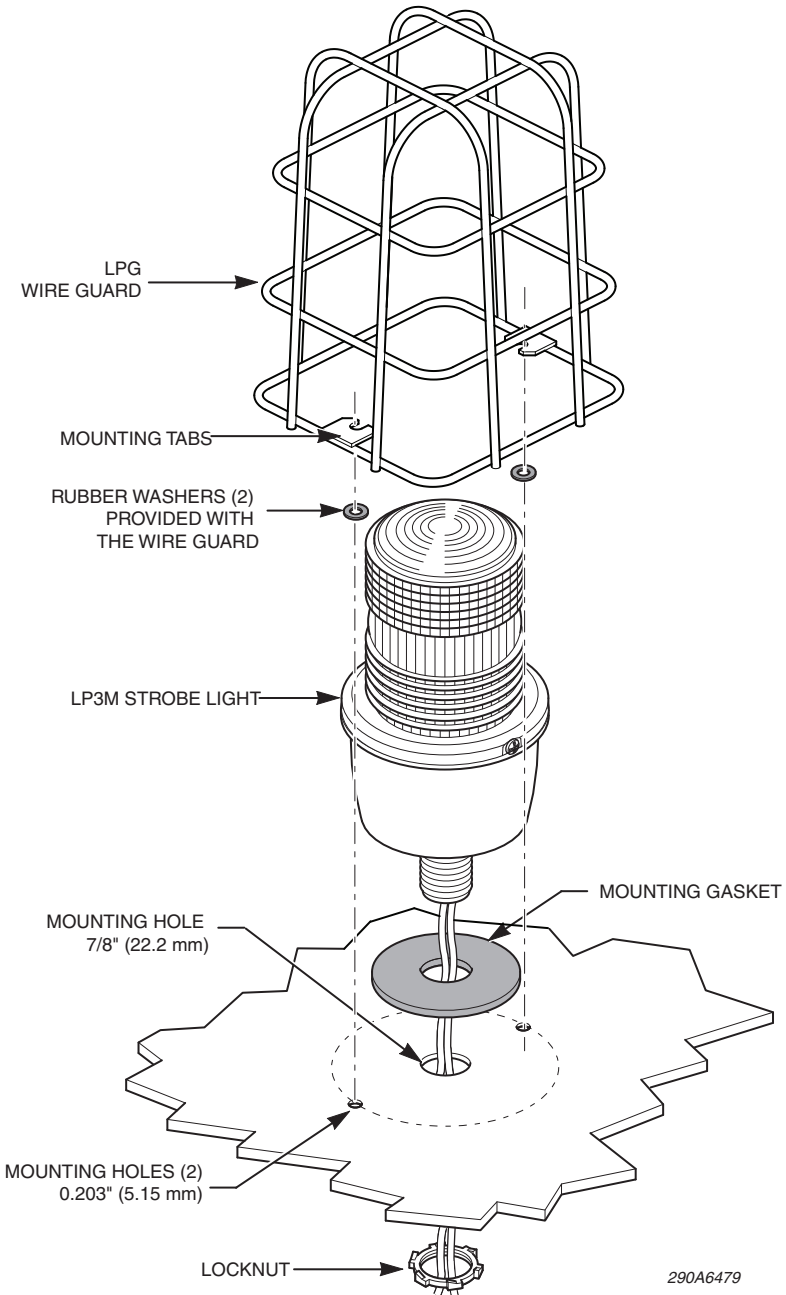

Figure 3 LP3S surface-mounted with wire guard

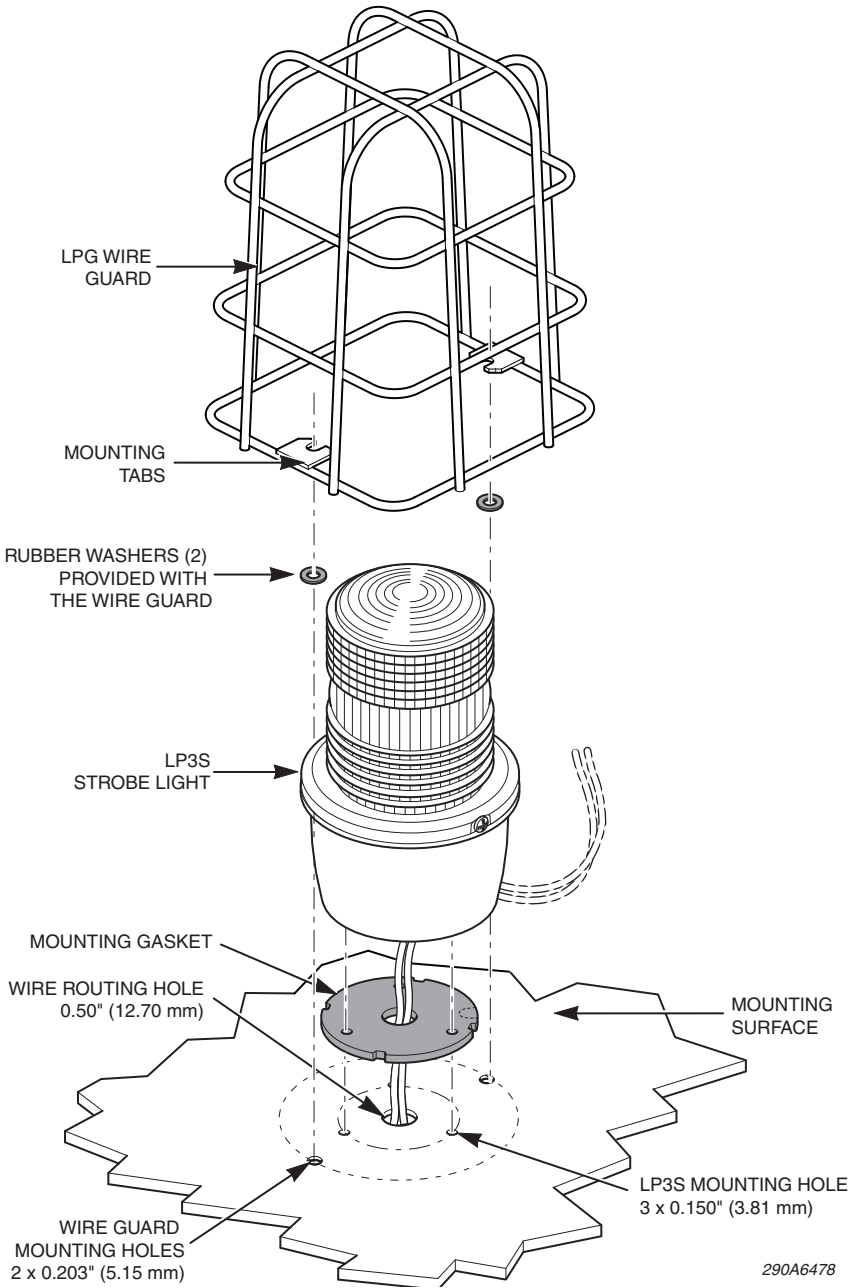
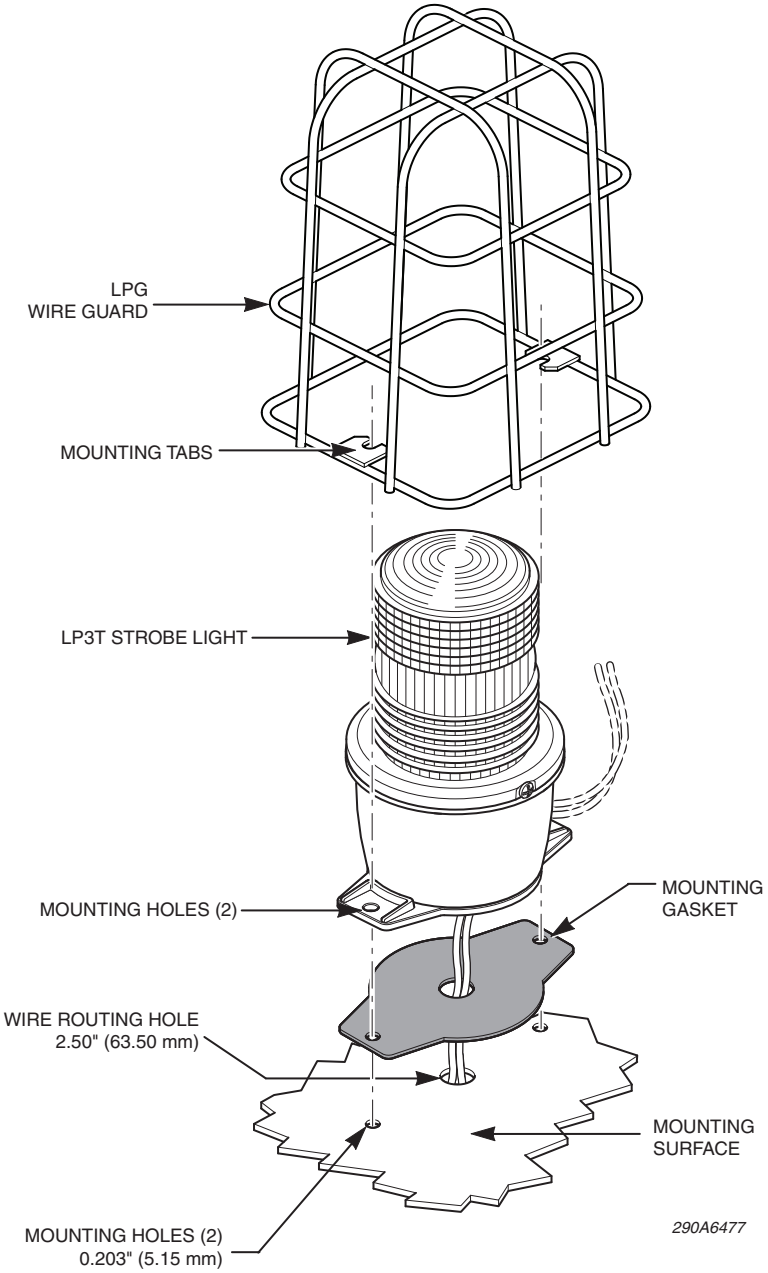

Figure 4 LP3T surface-mounted with wire guard



Obtaining Service, Assistance, and Parts

Products returned for repair require a Return Authorization form. To obtain service for the product, please contact the Federal Signal Service Department at 708-534-4858.

For technical assistance, please call Federal Signal Technical Support at 708-534-3424, extension 5823.

To order replacement parts, please call Federal Signal **Customer Support** at 708-534-4756.

Returning the Product for Credit

Product returns for credit require a return authorization from your local distributor prior to returning the product to Federal Signal. Please contact your distributor for assistance.

A product is qualified to be returned for credit when the following conditions are met:

- Product is resalable and in the original cartons
- Product has not been previously installed
- Product is the current revision
- Product has not been previously repaired
- Product is a standard product
- Product is not a service part

All returns are subject to a re-stock fee.

Defective products that are returned within the warranty period will be repaired or replaced at Federal Signal's sole discretion. Defective products do not include those products with lamp failure.

Circumstances other than those listed above will be addressed on a case-by-case basis.



Federal Signal Corporation
Industrial Systems
2645 Federal Signal Drive
University Park, IL 60484-3167, U.S.A.