

**Atkinson Dynamics Intercoms**  
**Models AD-26, AD-27, AD-56, and AD-57**

**Installation and Service Instructions**

Address all communications and shipments to:



**ATKINSON DYNAMICS**

A FEDERAL SIGNAL COMPANY

2645 Federal Signal Drive

University Park, IL 60466-3195

(888)751-1500

# INSTALLATION AND SERVICE INSTRUCTIONS FOR ATKINSON DYNAMICS HEAVY-DUTY INTERCOMS

## SAFETY MESSAGE TO INSTALLERS, USERS AND MAINTENANCE PERSONNEL

It is important to follow all instructions shipped with this product. This device is to be installed by a trained electrician who is thoroughly familiar with the National Electrical Code and will follow NEC Guidelines as well as local codes. Marine installations shall be in accordance with Title 46, CFR, Parts 110-113.

The selection of the mounting location for the device, its controls and the routing on the wiring is to be accomplished under the direction of the facilities engineer and the safety engineer. In addition, listed below are some other important safety instructions and precautions you should follow:

- This is not a listed safety device and is not intended to be used as such.
- Read and understand all instructions before installing or operating this equipment.
- Disconnect power before connecting or doing any maintenance on this intercom.
- All effective warning speakers produce loud sounds which may cause in certain situations, permanent hearing loss. You should take appropriate precautions such as wearing hearing protection.
- After testing is complete, provide a copy of this instruction sheet to all operating personnel.
- Establish a procedure to routinely check the intercom installation for integrity and proper operation. Any maintenance must be performed by a trained electrician in accordance with NEC guidelines and local codes.
- This device can be installed in climates with wind blown dust and rain or splashing water. Do not install this device in climates that exceed the unit's operating temperature range.

Failure to follow all safety precautions and instructions may result in property damage, serious injury, or death to you or others.

### A. General Features.

The Atkinson Dynamics intercom is a heavy-duty, 2-way, communications device designed for industrial applications. There are four basic models: AD-26, 12VDC; AD-56, 24VDC; AD-27, 120VAC 50/60Hz; and AD-57, 240VAC 50/60Hz. The AC line is fused with a 1/2-amp 250 volt type GMC fuse in the 120/240VAC units. A description of the available models follows.

Basic Model Specifications				
	Model AD-26	Model AD-56	Model AD-27	Model AD-57
Supply Voltage	12 VDC	24VDC	120VAC, 50/60 Hz	240VAC, 50/60 Hz
Audio Power Output (Max.)	8.0 Watts	11.7 Watts	11.3 Watts	11.3 Watts
Power Consumption (Max.)	20.0 Watts	39.6 Watts	28.8 Watts	30.5 Watts
Operating Current (nominal)	1.47 A	1.65 A	0.240 A	0.127 A
Operating Temperature	-31°F to 150°F	-31°F to 150°F	-31°F to 150°F	-31°F to 150°F
Shipping Weight	10 lbs.	10 lbs.	10 lbs. 11 oz.	10 lbs. 11 oz.
Dimensions	See Figure 20	See Figure 20	See Figure 20	See Figure 20
Ratings	UL, cUL, Marine-Listed, CE (Model AD-27) NEMA-Type 4X (excluding microphone models), Type IP56 (Model AD-27)			

*Table 1*

<b>Additional Model Information</b>	
<b>Letter Group</b>	<b>Function/Feature</b>
“A”	Call button
“C”	Master mode
“D”	Slave mode
<b>Number Group</b>	
“-1”	Remote power
“-2”	Provisions for external talk/listen switch (Foot pedal ready)
“-3”	External call contacts for auxiliary signal
“-4”	Extreme temperature use (-50°F to 150°F)
“-6”	Designed for use in a zoned system
“-7”	Provisions for hand-held noise canceling microphone
“-8”	Additional pre-amp for use with remote slave speaker
<b>Miscellaneous</b>	
“-M22”	Equipped with remote monitor switch
“-M34”	Provisions for headset microphone with belt switch
“-M44”	Remote speaker volume control

Table 2

**MASTER UNITS:**

“C” Models default to Master, or *speaker*, mode. In Master mode, the unit acts as a speaker and broadcasts audio signals generated elsewhere in the intercom system. Depressing the Talk switch turns the unit into a microphone and enables the user to broadcast to all other intercoms in the system. Releasing the switch returns the unit to Master mode. Figure 4 illustrates a Master/Slave intercom system.

**SLAVE UNITS:**

“D” Models default to Slave, or *microphone*, mode. In Slave mode, the unit is designed to serve as a hands-free microphone with transmission to all Master units in the intercom system. The Slave unit will act as a speaker and broadcast audio transmissions only when the Talk switch of any Master unit in the intercom system is depressed. Figure 4 illustrates a Master/ Slave intercom system.

**CALL BUTTON:**

“A” Models are equipped with a Call switch. Depressing the call switch transmits an 890Hz tone to all units in the intercom system.

**CAUTION**

The call signal is louder than normal voice messages being carried on the line. Do not depress the call switch while carrying on a conversation with someone on the system. This will subject the listener to very loud sound levels.

The volume of the call signal is affected by the volume control on the receiving unit, so if volume is turned all the way down at a receiving station, the call signal will not be heard.

**MICROPHONE:**

“-7” Hand-Held Noise Cancelling Microphones are recommended for use in environments with high levels of ambient noise. Keying the microphone overrides the default mode of the intercom and enables audio transmission to all Master units in the intercom system. Figure 2 illustrates a common intercom system where hand-held microphones are used.

**HEADSET MICROPHONE WITH-BELT-SWITCH:**

“M34” Headset Microphones and Belt Switches are an additional option for environments with a high level of ambient noise. Keying the belt switch overrides the default mode of the intercom and enables audio transmission to all Master units in the intercom system. Figure 5 illustrates a common intercom system where a headset microphone and belt switch are used.

**REMOTE POWER:**

“-1” Models are designed to provide power to “-1” remote intercom units. The AC-powered main unit provides 12 Volts DC-power and audio in the same cable to the remote unit. A “-1” unit can provide power to just one remote unit. Figure 3 illustrates this configuration.

**PRE-AMPLIFIER:**

“-8” Models are equipped with a pre-amplifier and are designed for use with Slave speaker units such as the AD-SV-25 Remote Speaker with Volume Control. The “-M44” option equips the “-8” Master unit with a knob for controlling the volume of remote speakers such as the AD-SF-25 Flush Mount Speaker or the AD-SS-25 Swivel Mount Speaker. Figures 6 and 7 illustrate intercom systems with the “-8” and “-M44” options.

**EXTERNAL-POWER-SOURCE:**

The use of an external power source allows the user to configure intercom systems made up of “-1” DC-powered Master and Slave units. Figure 8 illustrates such a system.

**SURGE PROTECTION:**

Metal Oxide Varistor (MOV) devices are used to protect the audio lines. The intercom must have Earth or Chassis Ground terminated to it to ensure surge protection.

The output amplifier of the Atkinson Dynamics intercom offers full short circuit protection and overheat protection on AC models only.

**FOOT PEDAL READY:**

Models with the “-2” option are designed for hands-free activation of the Talk/Listen switch. Figures 9, 10, and 17 show examples of intercoms with this option. A heavy-duty foot pedal (Model ADFP) is available through Atkinson Dynamics.

**AUXILIARY SIGNAL:**

Models with the “-3” option are equipped with a call button that provides a contact closure for an attention-getting auxiliary device, e.g. a strobe light. Figure 13 demonstrates an intercom system with this option. Atkinson Dynamics offers a low profile strobe light that is available with an amber or red lens, pipe or surface mount configuration, and in three voltage variations.

**ZONED SYSTEM REMOTE:**

Models with the “-6” option are designed for use in a zoned system. Figure 11 illustrates a zoned intercom system. A master intercom can select (via a switch box) to talk to any one or more remotes in a system. Each remote unit is equipped with a Talk/Listen switch that enables communication to the master intercom, even when that zone is not selected. Atkinson Dynamics offers 6-zone and 12-zone switch boxes.

**MONITOR SWITCH:**

Models with the “-M22” option are equipped with a monitor on/off toggle switch. When the monitor switch is in the on position, the remote unit becomes a slave and defaults to talk mode. Figures 14 and 15 illustrate systems with this feature.

**B. Unpacking.**

After unpacking the Atkinson Dynamics Intercom, examine it for damage that may have occurred in transit. If the equipment has been damaged, do not attempt to install or operate it, and file a claim immediately with the carrier stating the extent of the damage. Carefully check all envelopes, shipping labels and tags before removing or destroying them.

Before attempting to install the intercom, be sure that all parts listed in the KIT CONTENTS LIST have been supplied.

**C. Kit Contents List.**

<u>Qty.</u>	<u>Description</u>	<u>Part Number</u>
1	Resistor, 1K, 1W	101216

**D. Mounting.**

**CAUTION**

The selection of the mounting location for the device, its controls and the routing of the wiring is to be accomplished under the direction of the facilities and the safety engineer.

**NOTE**

Intercoms supplied with flexible cords for connection to field wiring are not intended for permanent mounting.

The intercom is intended to be mounted on any relatively flat and rigid surface by the two mounting ears on the exterior of the housing. Figure 9 is a dimensional outline drawing showing the proper mounting configuration. The two mounting ears are 13/32" diameter holes spaced 5.68" apart. Hardware for mounting the intercom to the surface shall be provided by the installer.

**WARNING**

This unit is heavy and should be mounted on a rigid surface capable of supporting the weight of the intercom.

**WARNING**

For shipboard applications, installations shall be in accordance with the United States Coast Guard, Title 46 CFR, Parts 110-113.

For units using the noise cancelling hand-held microphone, install the supplied microphone mounting clip on any rigid surface near the intercom. Avoid locating the microphone where it may be exposed to excessive moisture or dust.

**E. Electrical Connections.**

Plug each intercom into a nearby power source with a protective earth grounding. The plug should remain readily accessible for disconnection. Connect the audio inputs in parallel.

Audio wires should be sized properly by your licensed installation electrician for your specified application.

Optional: A 1K, 1W resistor is included in a kit with each intercom. Installing the resistor across the audio lines helps to reduce noise in certain environments. Only one resistor needs to be installed on the lines for any system installation.

See figures 1 through 19 for typical intercom connections and wiring information.

## **F. Service.**

### **1. General.**

Federal Signal will service your equipment or provide technical assistance with any problems that cannot be handled locally.

Any units returned to Atkinson Dynamics for service, inspection, or repair must be accompanied by a Return Material Authorization. This R.M.A can be obtained only from the factory by calling (888)751-1500.

At this time a brief explanation of the service requested or the nature of the malfunction, should be given.

Address all communications and shipments to:

**ATKINSON DYNAMICS**  
Service Department  
2645 Federal Signal Drive  
University Park, IL 60466-3195

## 2. Replacement Parts.

### WARNING

Replace fuse with GMC-1/2 only. DO NOT substitute.

<u>Description</u>	<u>Part Number</u>
Belt switch assembly	K137146B
Connector, 3-Position (12/24V PC Boards)	K140411A-03
Cover plate gasket	K8590013B
Fuse, GMC-1/2	K148A155A
Headset assembly	K137145A
Knob, volume control	K141A129A
Microphone assembly	K137144A
PC Board, 120VAC	K2001875B
PC Board, 120VAC, w/headset	K2001875B-M34
PC Board, 12V, AD-26	K2001878B
PC Board, 12V, AD-26-7	K2001878B-06
PC Board, 12V, AD-26-8	K2001896B-01
PC Board, 12V, AD-26-8-M44	K2001896B
PC Board, 12V, AD-26A	K2001878B-05
PC Board, 12V, AD-26C	K2001878B-01
PC Board, 12V, AD-26D	K2001878B-02
PC Board, 12V, AD-26SA-25	K2001878B-17
PC Board, 240VAC	K2001875B-01
PC Board, 240VAC, w/headset	K2001875B-01M34
PC Board, 24V, AD-26SA-25	K2001878B-19
PC Board, 24V, AD-56	K2001878B-07
PC Board, 24V, AD-56-8	K2001896B-03
PC Board, 24V, AD-56-8-M44	K2001896B-02
PC Board, 24V, AD-56A	K2001878B-12
PC Board, 24V, AD-56C	K2001878B-08
PC Board, 24V, AD-56D	K2001878B-09
PC Board, 120VAC, -1 Models	K2001885A
PC Board, 240VAC, -1 Models	K2001885A-01
Kit, potentiometer w/ on/off switch	K8590236A
Kit, push button switch (12/24V models)	K8590242A
Kit, push button switch (120/240V models)	K8590241A
Resistor, 1K, 1W	K101216A
Rubber boot, push button switch	K288697A
Rubber boot, toggle switch	K288696A
Rubber boot, volume control	K288A542A
Kit, toggle switch, DPDT	K8590238A
Kit, potentiometer, 10K Ohm	K8590237A
Kit, toggle switch, 3PDT (AD-27A-M34 & AD-27A-4-M34 only)	K122342A
Kit, toggle switch, 3PDT	K8590239B
Kit, pushbutton switch, 3PDT	K8590288A
Kit, potentiometer, 1K Ohm	K8590289A
Voice Coil/Diaphragm Assembly-Series C	K8590181A

### G. Warranty.

Atkinson Dynamics guarantees their intercoms to be free of defects at the time of delivery. If damage is found to be a factory defect, Atkinson Dynamics will warrant all labor charges for repair for one full year, and all replacement parts for two full years.

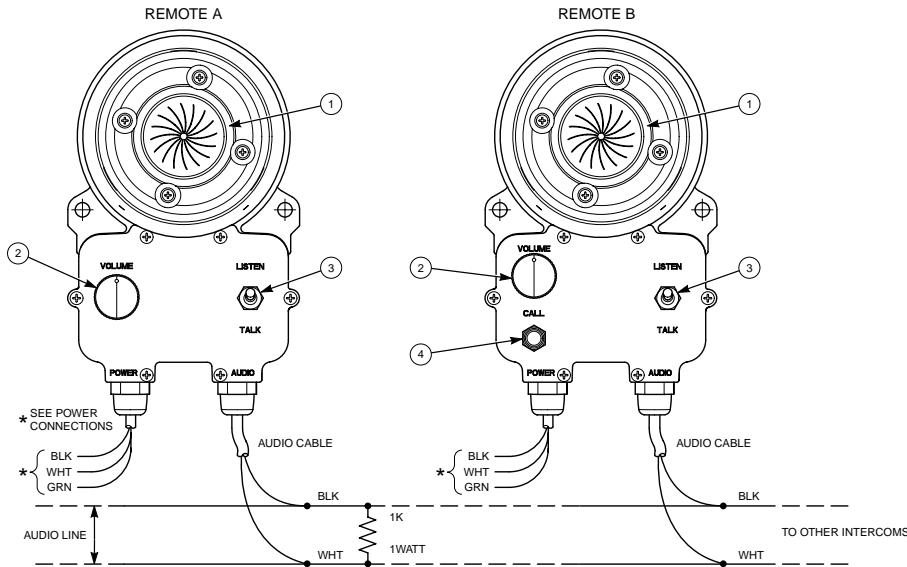

**Operating Principle:**

- When one talks, all intercoms will hear.
  - To talk to other stations, press the talk/listen switch and speak into the speaker/microphone.
- Release talk switch to listen.

**NOTES:**

1. Speaker/Microphone
2. Off/On/Speaker Volume Control
3. Talk/Listen Switch
4. "Call" Tone Switch

Power	Remote A	Remote B
12-18VDC	AD-26	AD-26A
120V 50/60Hz	AD-27	AD-27A
22-30VDC	AD-56	AD-56A
240V 50/60Hz	AD-57	AD-57A

**POWER CONNECTIONS:**

BLK	+DC Power	12/24V Models
	HOT	120/240V
Models		
WHT	Common	12/24V Models
	Neutral	120/240V
Models		
GRN	Earth Ground	120/240V Models only

**Reminders:**

- Before installing remote intercoms, precautions should be taken to prevent feedback between two or more remotes in close proximity and acoustically reflective areas.
- 16-20 gauge low voltage audio cable. Twisted pair not required..
- Shielded audio cable not required unless operating in high electromagnetic fields. Ground one end of the shield to earth ground.
- Type of power cable depends on intercom model.
- 7 foot provided for audio and power.

290A3693



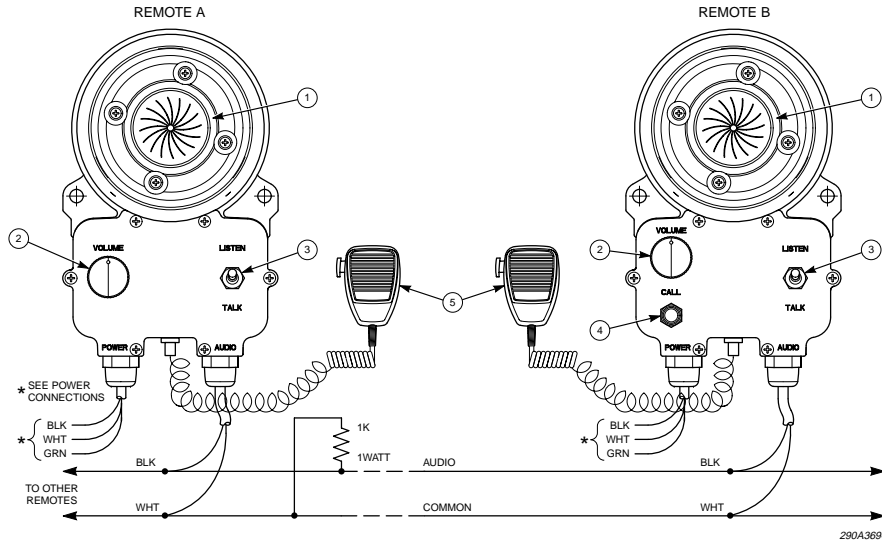

### Operating Principle:

- When one talks, all remotes will hear.
- To talk, press talk switch and speak into speaker/microphone. Release talk switch to listen.
- To talk into hand-held microphone, press talk switch on microphone and speak into microphone element.

### NOTES:

1. Speaker/Microphone
2. Off/On/Speaker volume control
3. Talk/Listen switch
4. "Call" Tone push button switch
5. #137144 hand-held, noise cancelling microphone with push-to-talk switch

### Power

12-18VDC  
120V 50/60Hz  
22-30VDC  
240V 50/60Hz

### Remote A

AD-26-7  
AD-27-7  
AD-56-7  
AD-57-7

### Remote B

AD-26A-7  
AD-27A-7  
AD-56A-7  
AD-57A-7

### POWER CONNECTIONS:

BLK	+DC Power	12/24V Models
HOT		120/240V Models
WHT	Common	12/24V Models
	Neutral	120/240V Models
GRN	Earth Ground	120/240V Models only

### Reminders:

- Before installing remote intercoms, precautions should be taken to prevent feedback between two or more remotes in close proximity and acoustically reflective areas.
- 16-20 gauge low voltage audio cable. Twisted pair not required.
- Shielded audio cable not required unless operating in high electromagnetic fields. Ground one end of the shield to earth ground.
- Type of power cable depends on intercom model.
- 7 foot (2 meter) cable provided for audio and power.

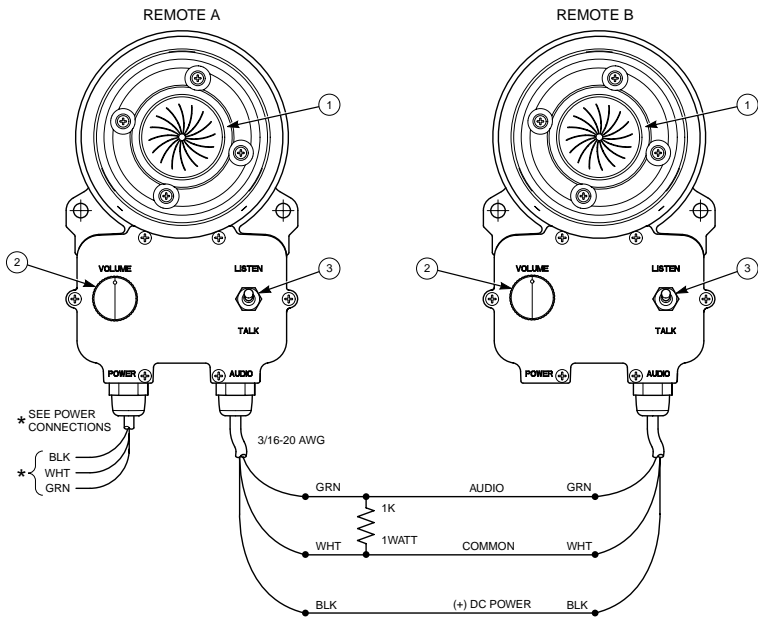

**Operating Principle:**

- When one talks, the other stations will hear.
- To talk into the intercom, press the talk switch and speak into the speaker/microphone. Release to listen.

**NOTES:**

1. Speaker/Microphone
2. Off/On/Speaker volume control
3. Talk/Listen Switch

**Power**

Not applicable  
120V 50/60Hz  
240V 50/60Hz

**Remote A**

AD-27-1  
AD-57-1

**Remote B**

AD-26-1

**POWER CONNECTIONS:**

BLK	+DC Power	12/24V Models
HOT		120/240V Models
WHT	Common	12/24V Models
	Neutral	120/240V Models
GRN	Earth Ground	120/240V Models only

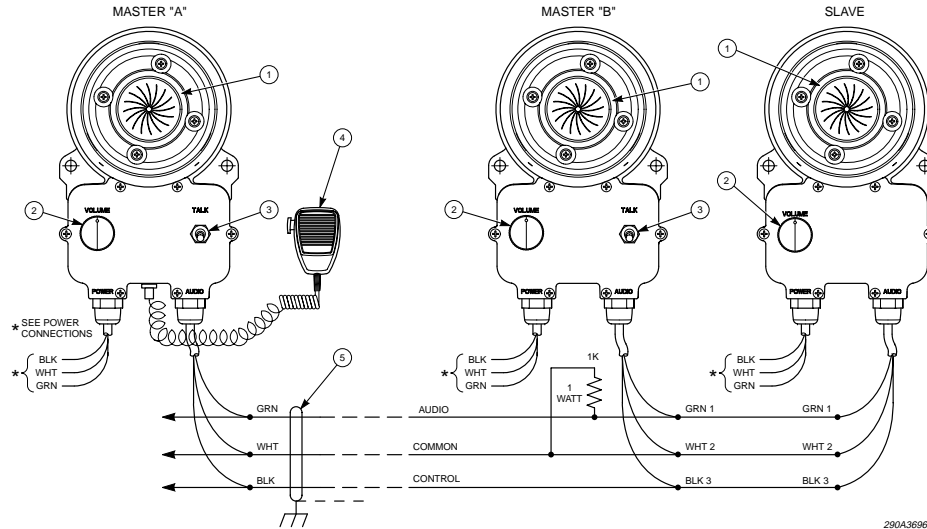

**Before installing remote intercoms, precautions should be taken to prevent feedback between two or more remotes in close proximity and acoustically reflective areas.**

**Operating Principle:**

- Masters normally listen to slave.
- Slave talks to master hands-free, without having to press a talk switch.
- When any master talks, slave hears. Other masters will hear.
- To talk into master, press talk switch and speak into speaker/microphone. Release talk switch to listen.
- To talk into hand-held microphone, press talk switch on microphone and speak into microphone element.

**NOTES:**

1. Speaker/Microphone
2. Off/On/Speaker volume control
3. Press-to-talk Switch
4. #137144 hand-held, noise cancelling microphone
5. 3-conductor/16–22 gauge cable. Use shielded cable in electrically noisy areas. Ground one end of the shield to “earth” ground. Ground chassis of DC unit to ground.

Power	Master A	Master B	Slave
12–18VDC	AD-26C-7	AD-26C	AD-26D
120V 50/60Hz	AD-27C-7	AD-27C	AD-27D
22-30VDC	AD-56C-7	AD-56C	AD-56D
240V 50/60Hz	AD-57C-7	AD-57C	AD-57D

**POWER CONNECTIONS:**

BLK	+DC Power	12/24V Models
	HOT	120/240V Models
WHT	Common	12/24V Models
	Neutral	120/240V Models
GRN	Earth Ground	120/240V Models only

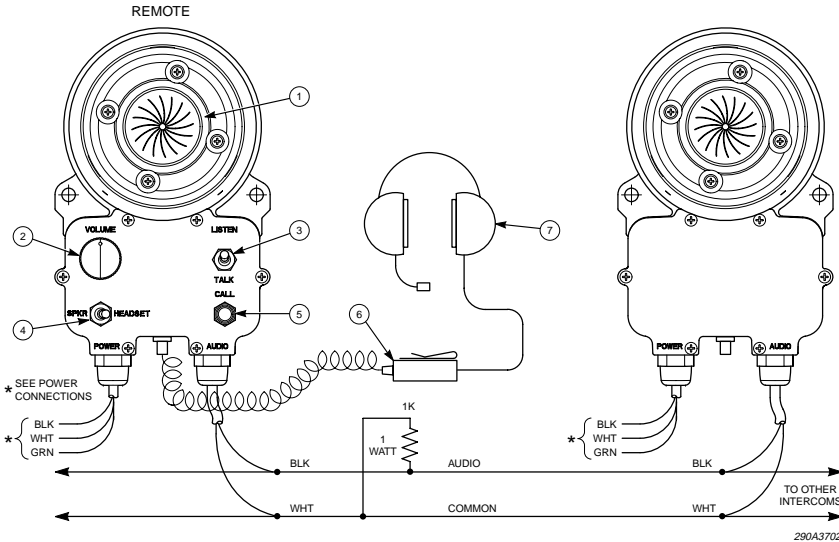

**Before installing remote intercoms, precautions should be taken to prevent feedback between two or more remotes in close proximity and acoustically reflective areas.**

**Operating Principle:**

- When one talks, all remotes will hear.
- To talk into remote, press talk switch and talk into speaker/microphone. Release talk switch to listen. (The headset speaker selector switch must be in “speaker” position to hear received audio signal on speaker.)
- To talk into headset, press belt “talk” switch and talk into headset microphone. Release belt switch to listen. (The selector switch must be in “headset” position.)

**NOTES:**

1. Speaker/Microphone
2. Off/On/Speaker volume control
3. Talk/Listen switch
4. Headset/Speaker selector switch
5. “Call” push button switch
6. #137146 Belt switch w/15 foot cord
7. #137145 Headset w/noise cancelling microphone

<u>Power</u>	<u>Remote A</u>
12-18VDC	AD-26A-M34
120V 50/60Hz	AD-27A-M34
22-30VDC	AD-56A-M34
240V 50/60Hz	AD-57A-M34

**POWER CONNECTIONS:**

BLK	+DC Power	12/24V Models
	HOT	120/240V Models
WHT	Common	12/24V Models
	Neutral	120/240V Models
GRN	Earth Ground	120/240V Models only

# 6

**POWER CONNECTIONS:**

BLK	+DC Power	12/24V Models
	HOT	120/240V Models
WHT	Common	12/24V Models
	Neutral	120/240V Models
GRN	Earth Ground	120/240V Models only

**NOTES**

1. Speaker/Microphone
2. Off/On Speaker Volume Control
3. Talk/Listen Switch
4. Remote Slave Station  
Model AD-SV-25

**Operating Principle:**

1. Slave station is both a speaker and a microphone.
2. Master is normally in "Listen" mode until the talk button is pressed to talk to remote.
3. Volume controls are for received signal volume only. They do not control transmitted signals.

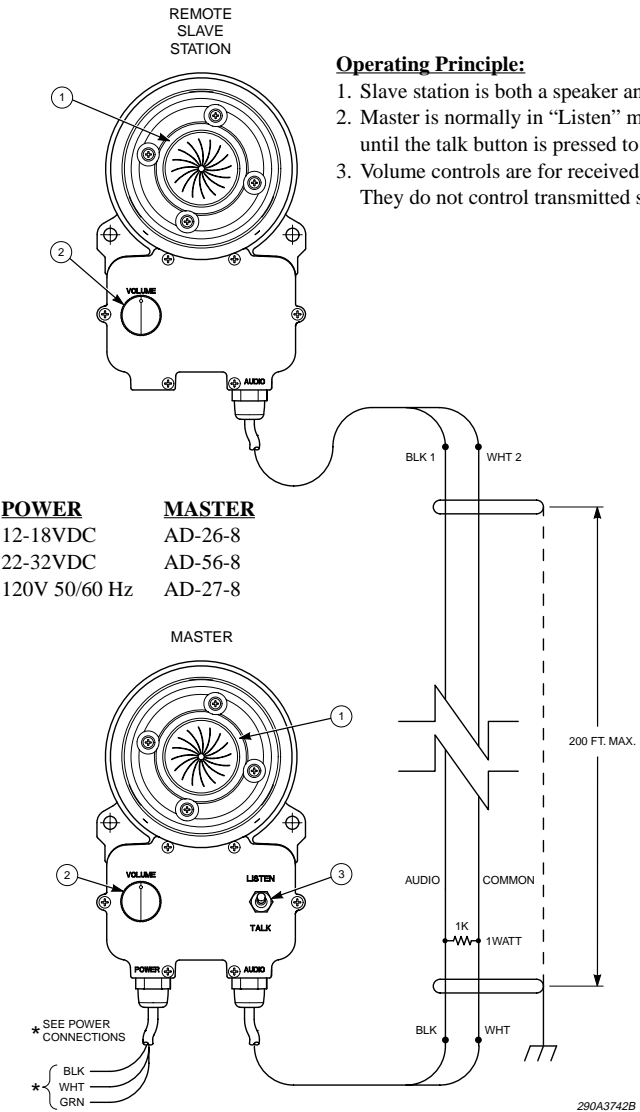

<b>POWER</b>	<b>MASTER</b>
12-18VDC	AD-26-8
22-32VDC	AD-56-8
120V 50/60 Hz	AD-27-8

290A3742B

7

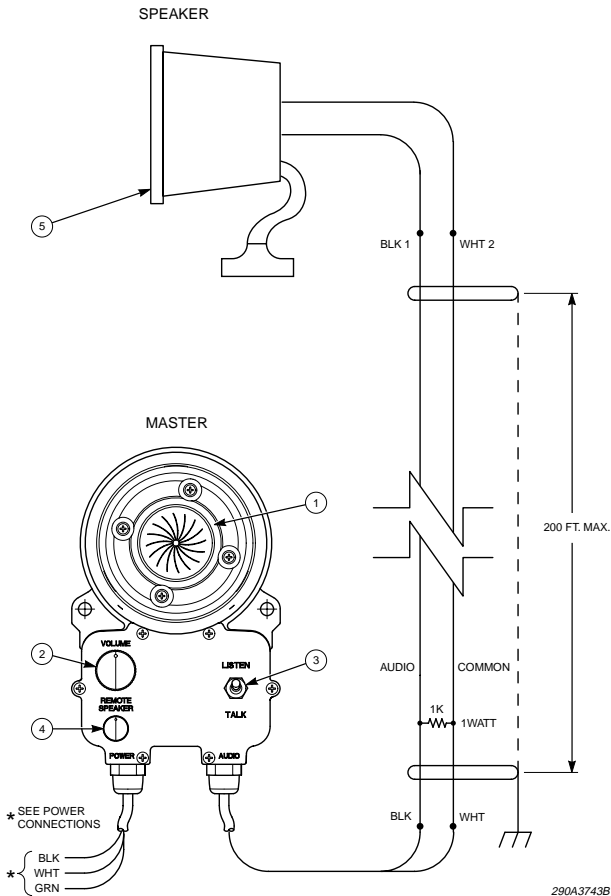

**Operating Principle:**

1. Slave station is both a speaker and a microphone.
2. Master is normally in "Listen" mode until the talk button is pressed to talk to remote.
3. Outgoing and incoming volumes are controlled by separate controls on master.

**NOTES:**

1. Speaker/Microphone
2. Off/On/Speaker volume control
3. Talk/Listen switch
4. Outgoing Volume Control
5. Speaker Model AD-SS-25 with swivel mounting bracket or Speaker Model AD-SF-25 with holes in outer flange for flush mounting

**POWER CONNECTIONS:**

BLK	+DC Power	12/24V Models
	HOT	120/240V Models
WHT	Common	12/24V Models
	Neutral	120/240V Models
GRN	Earth Ground	120/240V Models only

**POWER**

- 12-18VDC
- 22-32VDC
- 120V 50/60 Hz
- 240V 50/60 Hz

**MASTER**

- AD-26-8-M44
- AD-56-8-M44
- AD-27-8-M44
- AD-57-8-M44



**Operating Principle:**

1. Masters normally listen to slave.
2. Slave talks to masters "hands-free", without having to press a talk switch.
3. When any master talks, slave hears. Other master will hear.
4. To talk into master, press talk switch and speak into speaker/microphone. Release talk switch to listen.
5. To talk into hand-held microphone, press talk switch on microphone and speak into microphone element.

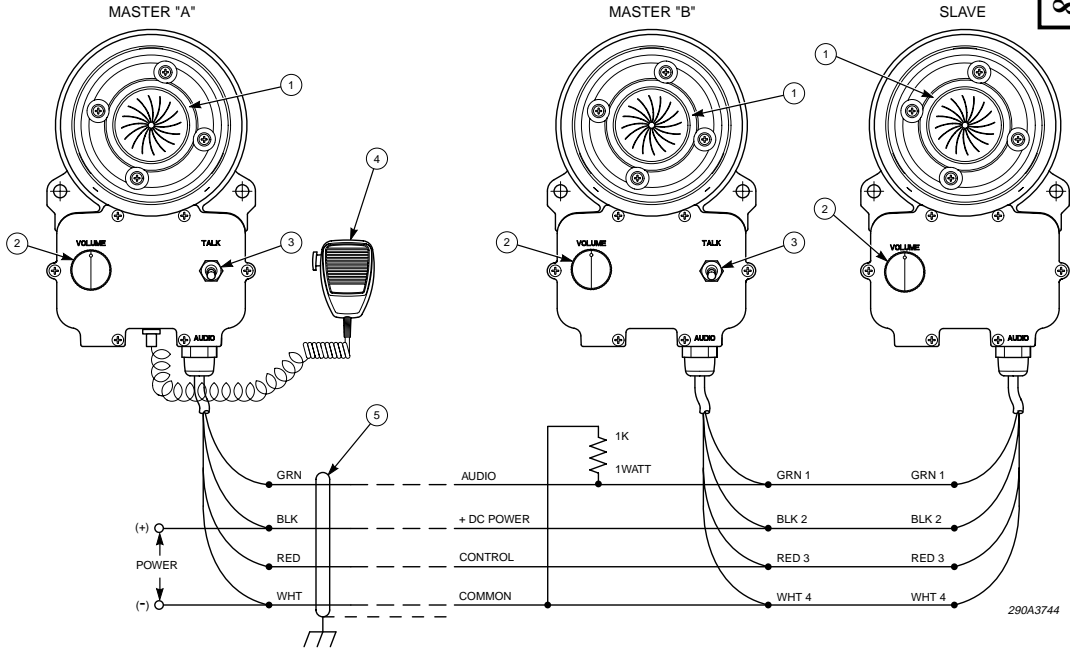

290A3744

**NOTES:**

1. Speaker/Microphone
2. Off/On/Speaker Volume Control
3. Press-to-Talk Switch
4. #137144 Hand-held, noise-cancelling microphone with push-to-talk switch

<u>POWER</u>	<u>MASTER A</u>	<u>MASTER B</u>	<u>SLAVE</u>
12-18VDC	AD-26C-1-7	AD-26C-1	AD-26D-1
22-32VDC	AD-56C-1-7	AD-56C-1	AD56D-1

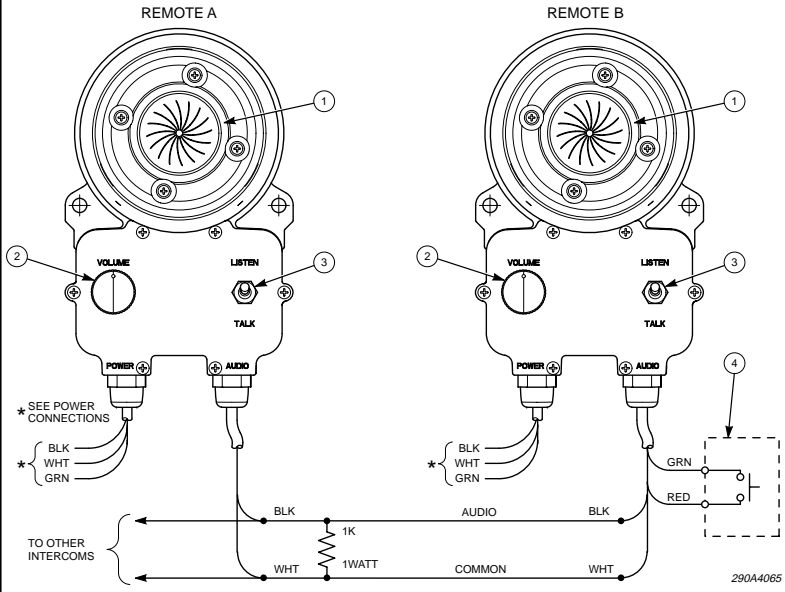

-15-

**Operating Principle:**

- When one talks, all intercoms will hear.
- To talk to other stations, press the talk/listen switch and speak into the speaker/microphone. Release talk switch to listen.
- To use external talk switch, close switch and speak into the speaker/microphone.

**NOTES:**

1. Speaker/Microphone
2. Off/On/Speaker Volume Control
3. Talk/Listen Switch
4. Customer-Supplied External Normally-Open Talk/Listen Switch, Momentary (e.g., foot switch)

Power	Remote A	Remote B
12-18VDC	AD-26	AD-26-2
120V 50/60Hz	AD-27	AD-27-2
22-30VDC	AD-56	AD-56-2
240V 50/60Hz	AD-57	AD-57-2

**POWER CONNECTIONS:**

BLK	+DC Power	12/24V Models
HOT		120/240V Models
WHT	Common	12/24V Models
	Neutral	120/240V Models
GRN	Earth Ground	120/240V Models only

290A4065



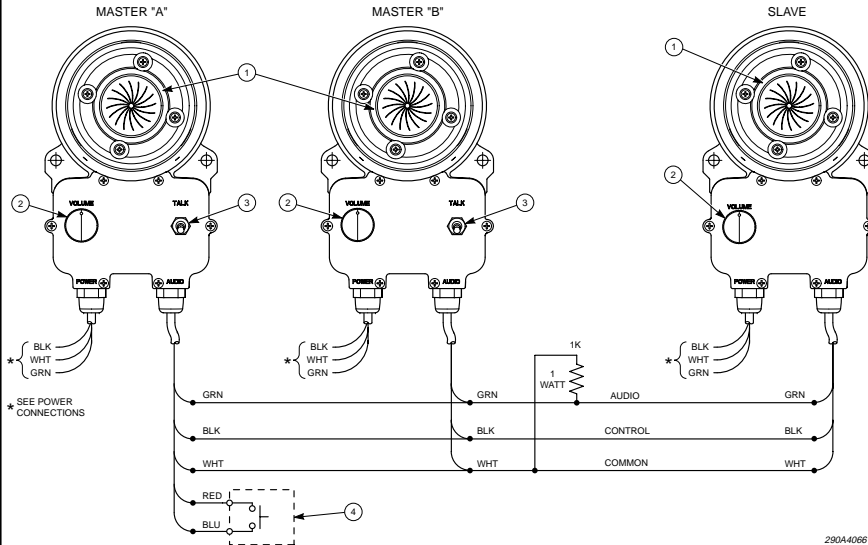

-16-

\* SEE POWER CONNECTIONS

### POWER CONNECTIONS:

BLK	+DC Power	12/24V Models
	HOT	120/240V Models
WHT	Common	12/24V Models
	Neutral	120/240V Models
GRN	Earth Ground	120/240V Models only

### Operating Principle:

- Masters normally listen to slave.
- Slave talks to master hands-free, without having to press a talk switch.
- When any master talks, slave hears. Other masters will hear.
- To talk into master, press talk switch and speak into speaker/microphone. Release talk switch to listen.
- Master "A" can talk by pressing either the talk switch or external switch (customer supplied).

### NOTES:

1. Speaker/Microphone
2. Off/On/Speaker Volume Control
3. Press-To-Talk Switch
4. Customer-Supplied External Normally-Open Press-To-Talk Switch, Momentary (e.g., foot switch)

Power	Master A	Master B	Slave
12-18VDC	AD-26C-2	AD-26C	AD-26D
120V 50/60Hz	AD-27C-2	AD-27C	AD-27D
22-30VDC	AD-56C-2	AD-56C	AD-56D
240V 50/60Hz	AD-57C-2	AD-57C	AD-57D

2904/4066



**POWER CONNECTIONS:**

BLK	+DC POWER	12/24V Models
	HOT	120/240V Models
WHT	Common	12/24V Models
	Neutral	120/240V Models
GRN	Earth Ground	120/240V Models only

**POWER REMOTE RA REMOTE RB REMOTE RC**

12VDC	AD-26-6	AD-26A-6	AD-26T-6
120V 50/60Hz	AD-27-6	AD-27A-6	AD-27T-6
240V 50/60Hz	AD-57-6	AD-57A-6	AD-57T-6

\*\* Refer to remote model number as an example for Master.

**NOTES:**

1. Desk Set speaker (microphone is mounted on handset)
2. Desk Set speaker volume control
3. Handset earpiece volume control (mounted on back of case)
4. Speaker/Microphone
5. Off/On/Speaker volume control
6. Talk/Listen switch
7. "Call" Tone Switch
8. Master switch box — customer supplied
9. DPDT selector (toggle) switch — customer supplied

**Operating Principle:**

1. Master can select (via master switch box) to talk to any one or more remotes.
2. Any remote can initiate a call to Master regardless of selector switch being on or off. Remote must specify its location. Remotes cannot talk to other remotes.
3. To talk into intercom, press talk switch and speak into speaker/microphone. Release talk switch to listen.
4. For Master to talk to remote, select desired remote via selector switch, press talk switch on handset microphone and talk into handset microphone.

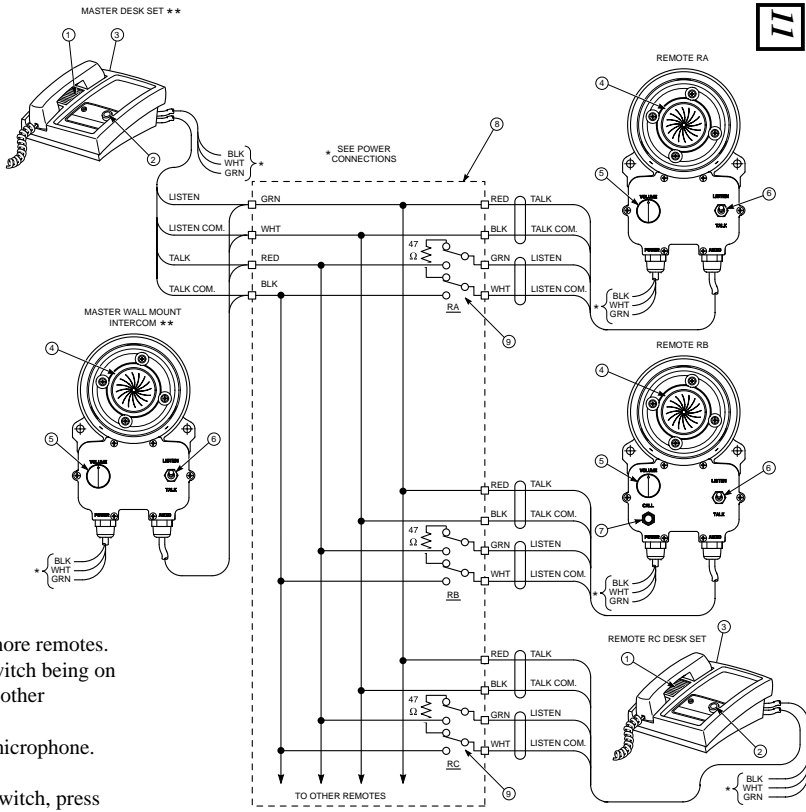

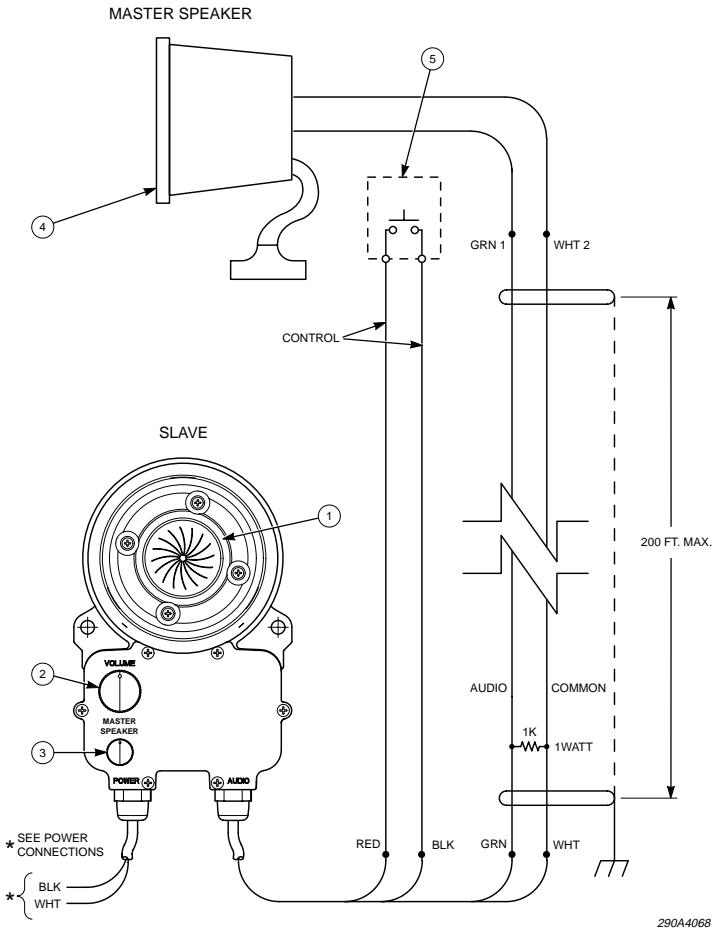

290A4068

**OPERATING PRINCIPLE:**

1. Master station is both a speaker and a microphone.
2. Master is normally in "Listen" mode until the PTT (press-to-talk) switch is pressed to talk to slave.
3. Outgoing and incoming volumes are controlled by separate controls on slave.
4. Slave talks to master hands-free, without having to press a talk switch.

**NOTES:**

1. Speaker/Microphone
2. Off/On/Speaker volume control
3. Outgoing Volume Control
4. Speaker Model AD-SS-25 with swivel mounting bracket or Speaker Model AD-SF-25 with holes in outer flange for flush mounting
5. PTT (press-to-talk) switch—customer supplied

**POWER CONNECTIONS:**

BLK	+DC Power	12/24V Models
WHT	Common	12/24V Models

**POWER**

12-18VDC

**SLAVE**

AD-26D-8-M44

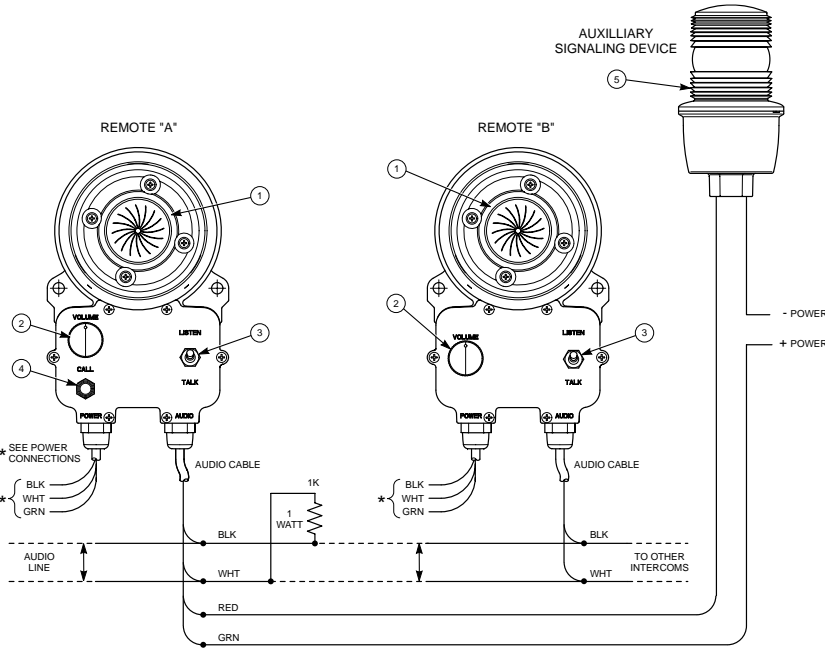

**Operating Principle:**

- When one talks, all intercoms will hear.
- To talk to other stations, press the talk/listen switch and speak into the speaker/microphone. Release talk switch to listen.
- Pressing the call button on remote A provides a contact closure for an attention-getting auxiliary signaling device, e.g. a strobe light.

**NOTES:**

1. Speaker/Microphone
2. Off/On/Speaker Volume Control
3. Listen/Talk Switch
4. "Call" Switch
5. Customer-Supplied Auxiliary Signaling Device (e.g., strobe light)

<u>Power</u>	<u>Remote A</u>	<u>Remote B</u>
12-18VDC	AD-26-3	AD-26
120V 50/60Hz	AD-27-3	AD-27
22-30VDC	AD-56-3	AD-56
240V 50/60Hz	AD-57-3	AD-57

**POWER CONNECTIONS:**

BLK	+DC Power	12/24V Models
HOT		120/240V Models
WHT	Common	12/24V Models
	Neutral	120/240V Models
GRN	Earth Ground	120/240V Models only

290A4069

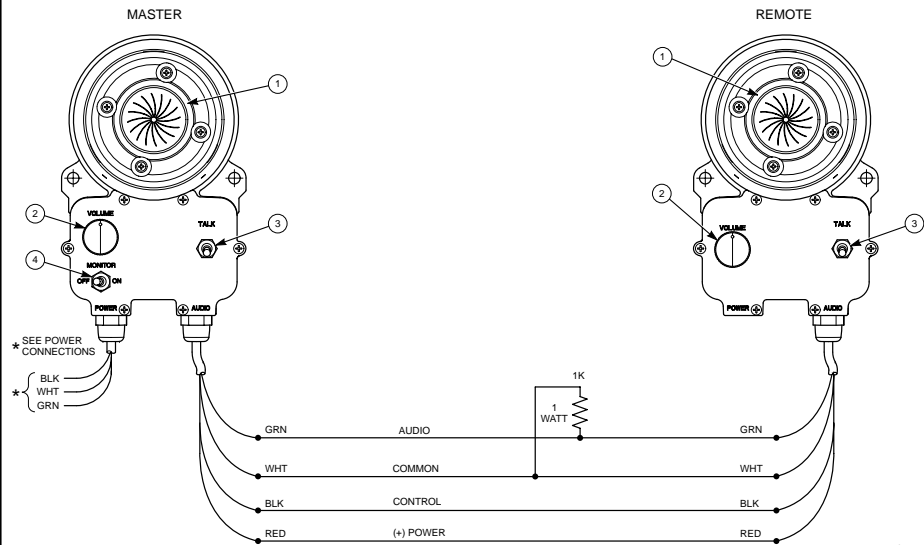

**Operating Principle:**

- Master presses talk switch to talk to remote.
- Master can turn monitor switch on and hear everything going on at remote.
- When master monitor switch is off, remote must press talk switch to talk to master.
- When master monitor switch is on, remote can talk to master hands-free without pressing the talk switch.
- Master supplies power to remote unit.

**NOTES:**

1. Speaker/Microphone
2. Off/On/Speaker Volume Control
3. Press-To-Talk Switch
4. Master Monitor Switch

<b>Power</b>	<b>Master</b>	<b>Remote</b>
Not applicable		AD-26-1-2
120V 50/60Hz	AD-27C-1-M22	

290A4070

**POWER CONNECTIONS:**

BLK	HOT	120/240V Models
WHT	Neutral	120/240V Models
GRN	Earth Ground	120/240V Models

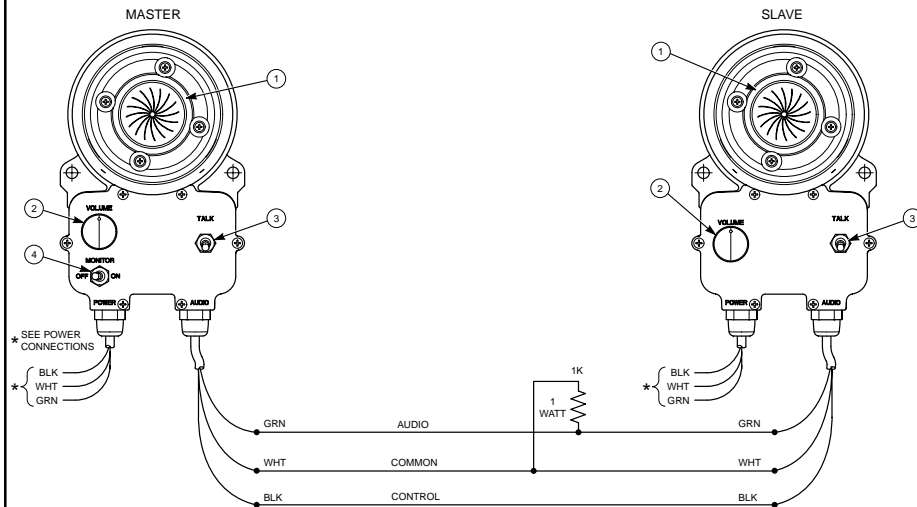

-21-

**Operating Principle:**

- Master presses talk switch to talk to slave.
- Master can turn monitor switch on and hear everything going on at slave.
- When master monitor switch is off, slave must press talk switch to talk to master.
- When master monitor switch is on, slave can talk to master hands-free without pressing the talk switch.

**NOTES:**

1. Speaker/Microphone
2. Off/On/Speaker Volume Control
3. Press-To-Talk Switch
4. Monitor On/Off Switch

**Power**

120V 50/60Hz

**Master**

AD-27C-M22

**Slave**

AD-27-2W3

**POWER CONNECTIONS:**

BLK	HOT	120/240V Models
WHT	Neutral	120/240V Models
GRN	Earth Ground	120/240V Models

290A4071

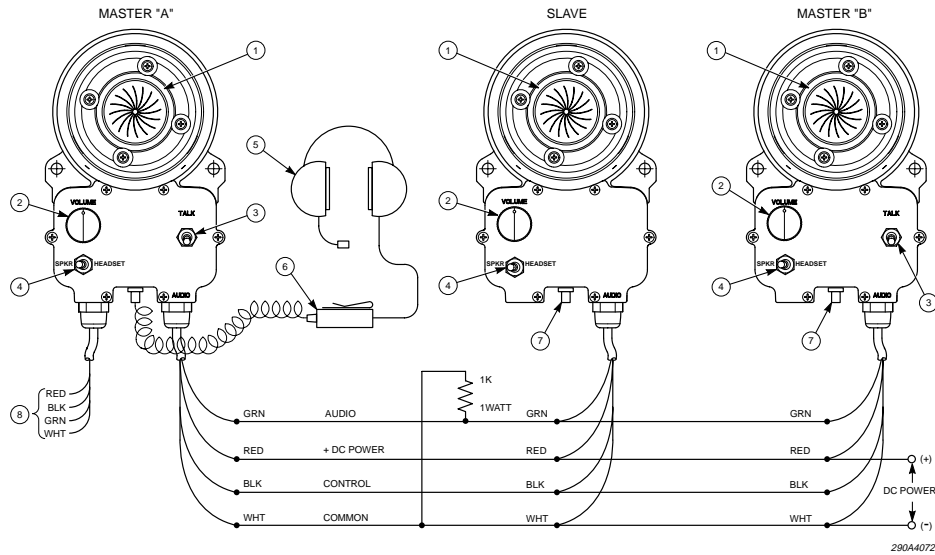

**Power**  
12-18VDC

**Master A**  
AD-26C-1-M80

**Master B**  
AD-26C-1-M34

**Slave**  
AD-26D-1-M34

**POWER CONNECTIONS:**

RED	+DC Power	12/24V Models
WHT	Common	12/24V Models

**Operating Principle:**

- Masters normally listen (monitor) slave.
- Slave can talk to master hands-free without having to press a talk switch.
- When one station talks, other stations will hear.
- To talk to other stations, master must press a talk switch on intercom or on belt switch.
- Master and slave can select to talk/listen on either the speaker/microphone or headset via selector switch.

**NOTES:**

1. Speaker/Microphone
2. Off/On/Volume Control
3. Press-To-Talk Switch
4. Headset/Selector Switch
5. #137145 Headset w/noise-canceling microphone
6. #137146 Belt switch w/15 ft. cord
7. Receptacle for headset
8. 12 ft. cord for remote customer-supplied headset receptacle

29044072

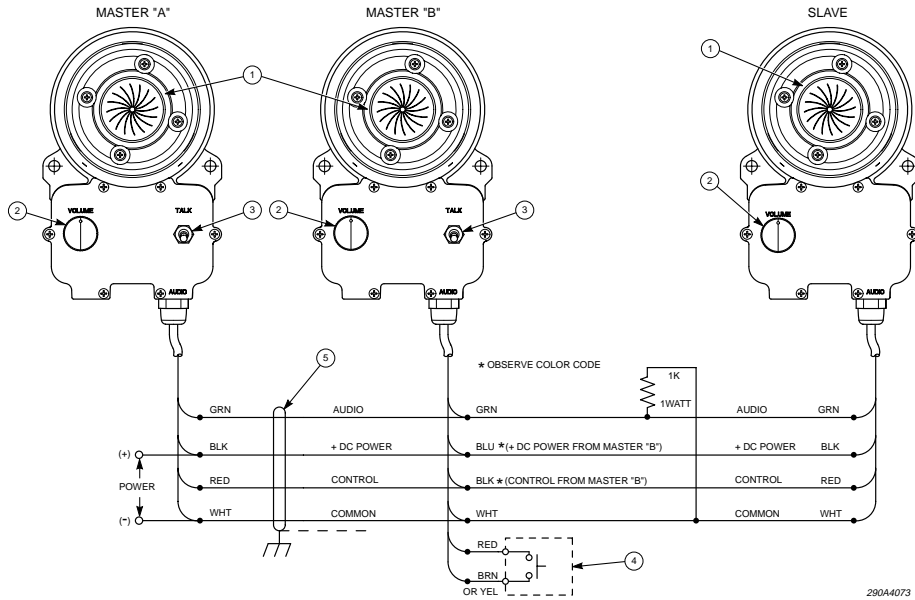

**Operating Principle:**

- Master normally listens to slave.
- Slave talks to master hands-free, without having to press a talk switch.
- When any master presses talk switch, slave hears. Other master will also hear.
- To talk into master, press talk switch and speak into speaker/microphone. Release talk switch to listen.
- Master B can talk by pressing either the talk switch or external switch (customer supplied).

**NOTES:**

1. Speaker/Microphone
2. Off/On/Speaker Volume Control
3. Press-To-Talk Switch
4. External Press-To-Talk Switch, Momentary (e.g., foot switch)
5. 4-conductor/16-22 gauge cable. Use shielded cable in electrically noisy areas. Ground one end of the shield to "earth" ground. Ground chassis of DC units to ground.

**Power**  
12-18VDC  
22-30VDC

**Master A**  
AD-26C-1  
AD-56C-1

**Master B**  
AD-26C-1-2  
AD-56C-1-2

**Slave**  
AD-26D-1  
AD-56D-1

**POWER CONNECTIONS:**

BLK	+DC Power	12/24V Models
WHT	Common	12/24V Models

290A4073



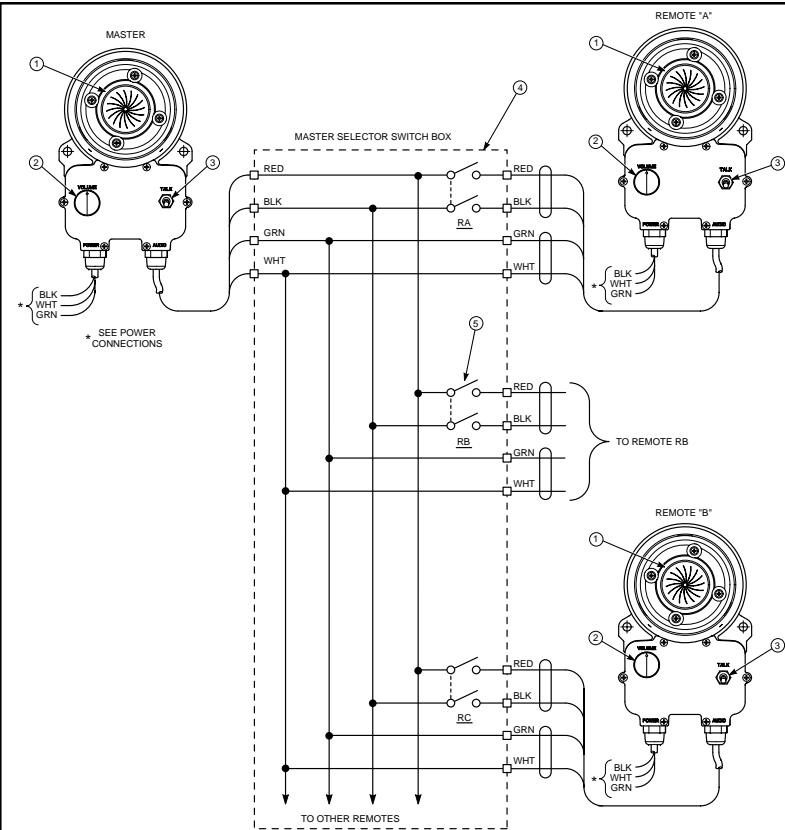

**Operating Principle:**

- Master can select to monitor any one or more remotes via master switch box.
- To talk to remote(s), master closes desired selector switch, presses talk switch, and speaks into the speaker/microphone. Master releases talk switch to listen.
- Selected remote(s) talk to master “hands-free” without having to press remote talk switch.
- Remotes cannot talk to other remotes.
- Remotes not selected by master cannot talk hands-free and must press talk switch to initiate call to master.
- When initiating a call to master, remote must specify its location for master to respond.

**NOTES:**

1. Speaker/Microphone
2. Off/On/Speaker Volume Control
3. Talk/Listen Switch
4. Master Selector Switch (customer supplied)
5. Double-Pole (OFF-ON) Toggle Selector Switch

<b>Power</b>	<b>Master</b>	<b>Remotes</b>
120V 50/60Hz	AD-27C-1	AD-27D-M49

**POWER CONNECTIONS:**

BLK	HOT	120/240V Models
WHT	Neutral	120/240V Models
GRN	Earth Ground	120/240V Models

## WIRING REFERENCE CHART

MODEL NO.	AUDIO CABLE				POWER CABLE		
	BLACK	WHITE	GREEN	RED	BLACK	WHITE	GREEN
AD-26-1-M34	+DC POWER	COMMON	AUDIO	N/A*	N/A*	N/A*	N/A*
AD-26C-M34	CONTROL	COMMON	AUDIO	N/A*	12-18 VDC	COMMON	N/A*
AD-26C-7-M82	CONTROL	COMMON	AUDIO	N/A*	12-18 VDC	COMMON	N/A*
AD-26D-1-M82	+DC POWER	COMMON	AUDIO	CONTROL	N/A*	N/A*	N/A*
AD-26D-1-M84	+DC POWER	COMMON	AUDIO	CONTROL	N/A*	N/A*	N/A*
AD-26SA-25	AUDIO	COMMON	N/A*	N/A*	12-18 VDC	COMMON	N/A*
AD-27-M34	AUDIO	COMMON	N/A*	N/A*	120V 50/60 Hz	NEUTRAL	EARTH GND
AD-27-M82	AUDIO	COMMON	N/A*	N/A*	120V 50/60 Hz	NEUTRAL	EARTH GND
AD-27-M83	AUDIO	COMMON	N/A*	N/A*	120V 50/60 Hz	NEUTRAL	EARTH GND
AD-27A-4-M34	AUDIO	COMMON	N/A*	N/A*	120V 50/60 Hz	NEUTRAL	EARTH GND
AD-27A-7-M83	AUDIO	COMMON	N/A*	N/A*	120V 50/60 Hz	NEUTRAL	EARTH GND
AD-27C-1(-4)	+DC POWER	COMMON	AUDIO	CONTROL	120V 50/60 Hz	NEUTRAL	EARTH GND
AD-27C-1-7(-4)	+DC POWER	COMMON	AUDIO	CONTROL	120V 50/60 Hz	NEUTRAL	EARTH GND
AD-27C-M34	CONTROL	COMMON	AUDIO	N/A*	120V 50/60 Hz	NEUTRAL	EARTH GND
AD-27D-1	+DC POWER	COMMON	AUDIO	CONTROL	120V 50/60 Hz	NEUTRAL	EARTH GND
AD-27SA-25	AUDIO	COMMON	N/A*	N/A*	120V 50/60 Hz	NEUTRAL	EARTH GND
AD-56C-M34	CONTROL	COMMON	AUDIO	N/A*	22-30 VDC	COMMON	N/A*
AD-56C-7-M82	CONTROL	COMMON	AUDIO	N/A*	22-30 VDC	COMMON	N/A*
AD-56SA-25	AUDIO	COMMON	N/A*	N/A*	22-30 VDC	COMMON	N/A*
AD-57-M83	AUDIO	COMMON	N/A*	N/A*	240V 50/60 Hz	NEUTRAL	EARTH GND
AD-57A-1(-4)	+DC POWER	COMMON	AUDIO	N/A*	240V 50/60 Hz	NEUTRAL	EARTH GND
AD-57A-7-M83	AUDIO	COMMON	N/A*	N/A*	240V 50/60 Hz	NEUTRAL	EARTH GND
AD-57C-M34	CONTROL	COMMON	AUDIO	N/A*	240V 50/60 Hz	NEUTRAL	EARTH GND
AD-57SA-25	AUDIO	COMMON	N/A*	N/A*	240V 50/60 Hz	NEUTRAL	EARTH GND

N/A\*: Not Applicable

20

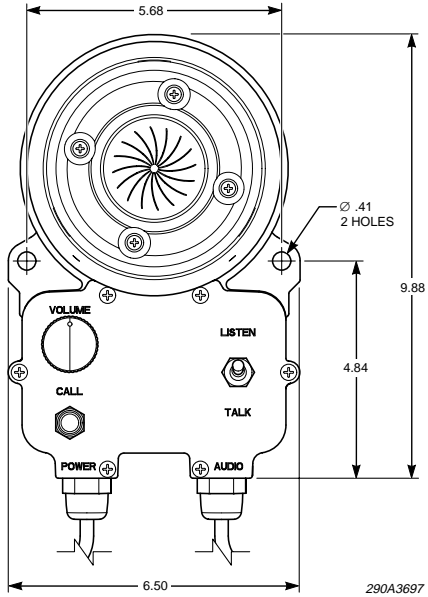
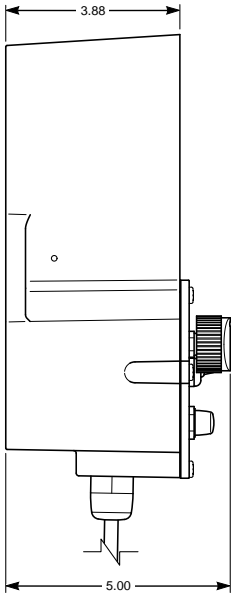

290A3697

2561494H  
REV. H Printed 11/06  
Printed in U.S.A.

