

L4182 Rev. B 03/17

Table of Contents:

Section	Page
1.0 IMPORTANT RECEIVING INSTRUCTIONS	1
2.0 SAFETY	1
3.0 CONFORMANCE TO NATIONAL AND INTERNATIONAL STANDARDS	2
4.0 PRODUCT DESCRIPTION	2
5.0 SETUP AND ASSEMBLY	2
6.0 OPERATION	4
7.0 TROUBLESHOOTING	6
8.0 PRODUCT DATA	7



1.0 IMPORTANT RECEIVING INSTRUCTIONS

Visually inspect all components for shipping damage. Shipping damage is not covered by warranty. If shipping damage is found, notify carrier at once. The carrier is responsible for all repair and replacement costs resulting from damage in shipment.

2.0 SAFETY

2.1 Introduction

Read all instructions carefully. Follow all recommended safety precautions to avoid personal injury as well as damage to the product and/or damage to other property. Enerpac cannot be responsible for any damage or injury from unsafe use, lack of maintenance or incorrect operation. Do not remove warning labels, tags, or decals. In the event any questions or concerns arise, contact Enerpac or your local Enerpac distributor for clarification.

If you have never been trained on high force tool safety, consult your distributor or service center for a free Enerpac safety course.

This manual follows a system of safety alert symbols, signal words and safety messages to warn the user of specific hazards. Failure to comply with these warnings could result in death or serious personal injury, as well as damage to the equipment or other property.



The **Safety Alert Symbol** appears throughout this manual. It is used to alert you to potential physical injury hazards. Pay close attention to Safety Alert Symbols and obey all safety messages that follow this symbol to avoid the possibility of death or serious personal injury.

Safety Alert Symbols are used in conjunction with certain Signal Words that call attention to safety messages or property damage messages and designate a degree or level of hazard seriousness. The Signal Words used in this manual are WARNING, CAUTION and NOTICE.



Indicates a hazardous situation that, if not avoided, **could** result in death or serious personal injury.



Indicates a hazardous situation that, if not avoided, **could** result in minor or moderate personal injury.



Indicates information considered important, but not hazard related (e.g. messages relating to property damage). Please note that the Safety Alert Symbol will **not** be used with this signal word.

2.2 Safety Precautions - Mechanical Sync Grip Pullers



Failure to observe and comply with the following precautions could result in death or serious personal injury. Property damage could also occur.

- Read and completely understand the safety precautions and instructions in this manual before operating the puller or preparing it for use.
- Wear appropriate personal protective equipment (PPE) such as safety glasses and face shield. The operator must take precautions against injury due to flying debris caused by possible failure of the tool or workpiece.
- During operation, keep hands and fingers away from the work area to avoid personal injury.
- Know the puller rated capacity before beginning any work.
- Do not use the puller in circumstances where a sudden release of mechanical force could result in loss of balance, causing damage or injury.
- Never attempt to pry the puller by inserting tools or other objects between the jaws. This may cause center bolt damage.
- It is impossible to predict the exact force needed for every pulling situation. The amount of press fit and force of removal can vary greatly between jobs. Set-up requirements along with the size, shape and condition of the parts being pulled

are variables which must be considered. Study each pulling application before you select your puller.

- Do not overload equipment. Use the correct size puller for your application. If you have applied significant force, and the part still will not move, then use a larger capacity puller. Use of sledge hammers to assist in removing components is not recommended.
- Do not overtighten the adjusting rod. Stop tightening if the adjusting rod bends, or if deformation of the jaws occurs.
- Do not use puller if threads on adjusting rod and/or body are damaged or worn. Do not use puller if adjusting rod is bent.
- Apply force gradually. Align puller grip jaws as required. Be sure the setup is rigid and that puller is square with the work.
- Make sure that all puller components are protected from external sources of damage, such as excessive heat, flame, moving machine parts, sharp edges and corrosive chemicals.
- Always perform a visual inspection of the puller before placing it into operation. If any problems are found, do not use the puller. Have the equipment repaired and tested before it is returned to service.
- Never use a puller that is damaged, altered or in need of repair.
- Always be sure that the adjusting rod is loosened before performing any puller adjustment or repair procedures. Never service the puller while it is installed and under tension.
- Always read, understand and follow all safety precautions and instructions, including those that are contained within the procedures of this manual.

CAUTION

Failure to observe and comply with the following precaution could result in minor or moderate personal injury. Property damage could also occur.

- Immediately replace worn or damaged parts with genuine Enerpac parts. Enerpac parts are designed to fit properly and to withstand high loads. Non-Enerpac parts may break or cause the product to malfunction.

NOTICE

- High force tool equipment must only be serviced by a qualified technician. For repair service, contact the Enerpac Authorized Service Center in your area.

3.0 CONFORMANCE TO NATIONAL AND INTERNATIONAL STANDARDS

CE Enerpac declares that this product has been tested and conforms to applicable standards and is compatible with all CE Requirements. A copy of an EU Declaration of Incorporation is enclosed with each shipment of this product.

4.0 PRODUCT DESCRIPTION

The SGM-Series Sync Grip Puller can be used to remove gears, bearings, pulleys and other similar shaft mounted parts.

The puller's self centering closing system means that all jaws move at the same time, reducing the chance of damage to the puller components and to the item being removed.

Five different puller models are available in rated capacities of 1 to 20 US Tons [8.9 to 177.9 kN]. Refer to the documentation provided with your shipment for model numbers and additional product data.

5.0 SETUP AND ASSEMBLY

5.1 Handling Large Pullers

- Use a crane and slings of suitable rated capacity to lift and unload the puller.
- Know the weight of the complete puller including puller body, adjusting rod and jaws.
- Be careful when lifting the puller while it is in the vertical position, as the jaws will close.
- If needed, support and reposition the puller with slings so that it can be used horizontally. When repositioning the puller from the horizontal to the vertical position, incline the puller slowly and carefully.

5.2 Configurations

Models SGM01, SGM04, SGM07 and SGM10 can be configured as either a two-jaw or three-jaw grip puller. Model SGM20 can be assembled only in the three-jaw configuration. See Figure 2 for jaw mounting details.

A three-jaw grip puller provides a more stable and secure grip than a two-jaw grip puller, resulting in a more even pulling force. For this reason, the three-jaw configuration should be used whenever possible.

Extended reach "long" jaws, are available as an optional accessory for models SGM10 and SGM20.

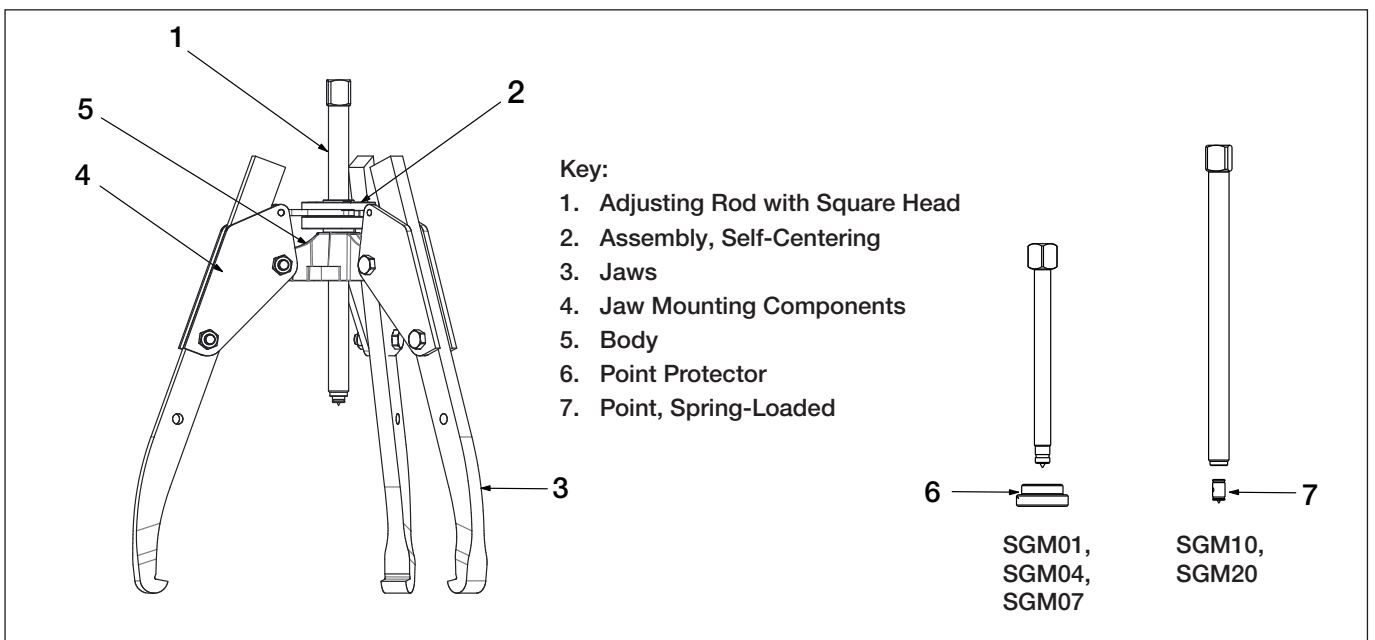
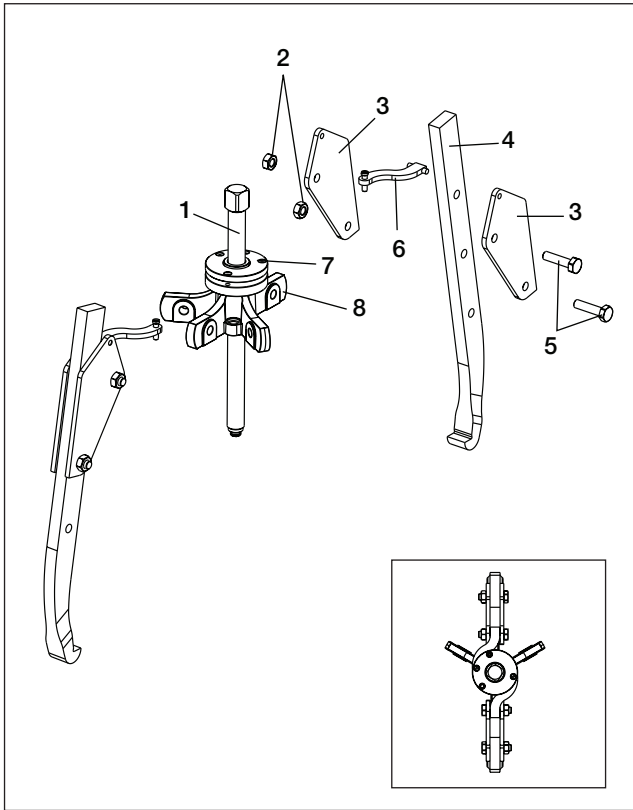
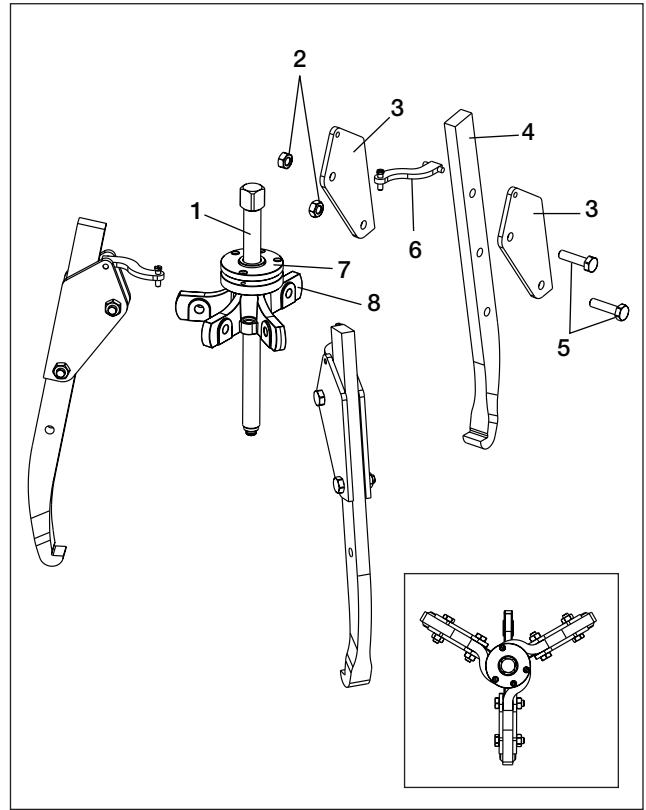

Figure 1, Features and Major Components, SGM-Series Sync Grip Puller



Two-Jaw Configuration
(Models SGM01, SGM04, SGM07 and SGM10)



Three-Jaw Configuration
(Models SGM01, SGM04, SGM07 and SGM10)

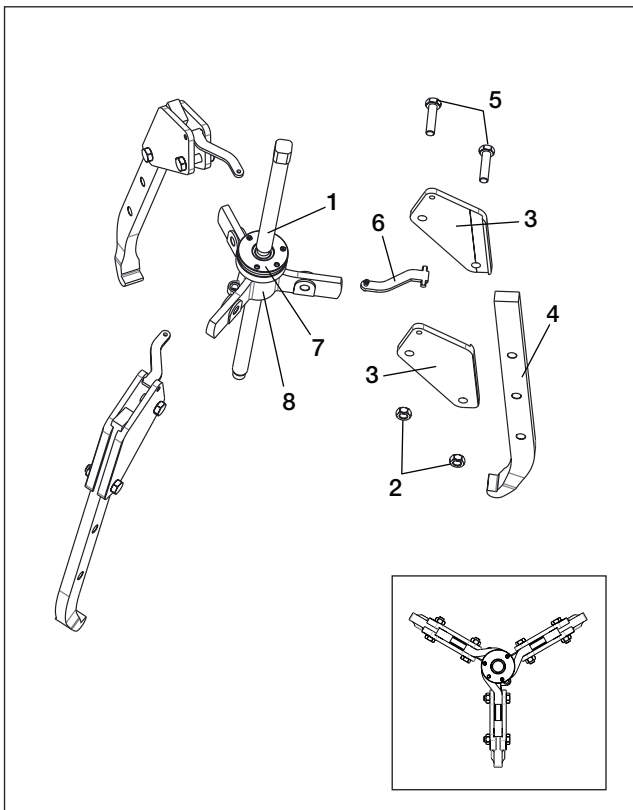

Three-Jaw Configuration
(Model SGM20)

Key:

1. Adjusting Rod with Square Head
2. Hex Nut
3. Plate
4. Jaw, Standard Length
Jaw, Extended Reach (optional)
5. Capscrew
6. Strap
7. Assembly, Self-Centering
8. Body

Note: Components shown in this figure are included with the SGM-Series Sync Grip Puller.

Extended reach "long" jaws are an optional accessory for all pullers.

Figure 2, Setup and Assembly

5.3 Adjusting Rod Point and Point Protector

- Model SGM01 SGM04 and SGM07 feature a standard adjusting rod, with a tempered non-retractable point. These models **MUST** be used with a point protector if the shaft end does not contain a drilled center hole. See Figure 3.
- Model SGM10 and SGM20 feature a special adjusting rod which contains a spring-loaded retractable point. The point engages if the shaft end has a drilled center hole or depression. It automatically retracts if the shaft end is flat. See Figure 4. No point protector is required for these models.

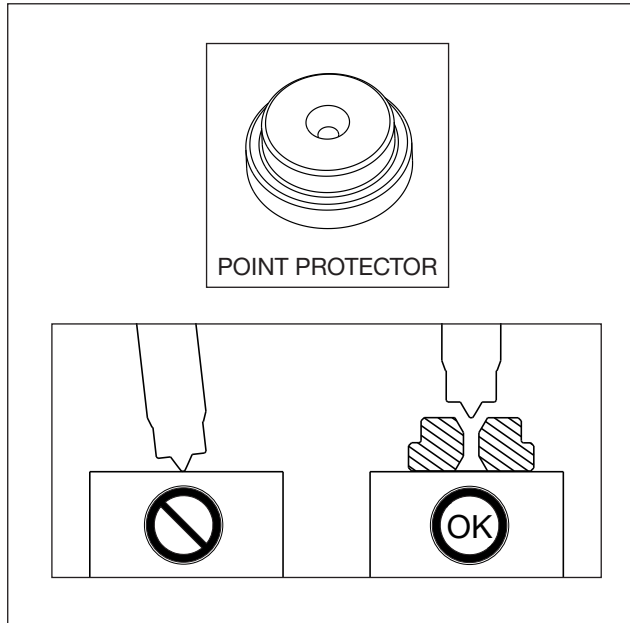

Figure 3, Point Protector

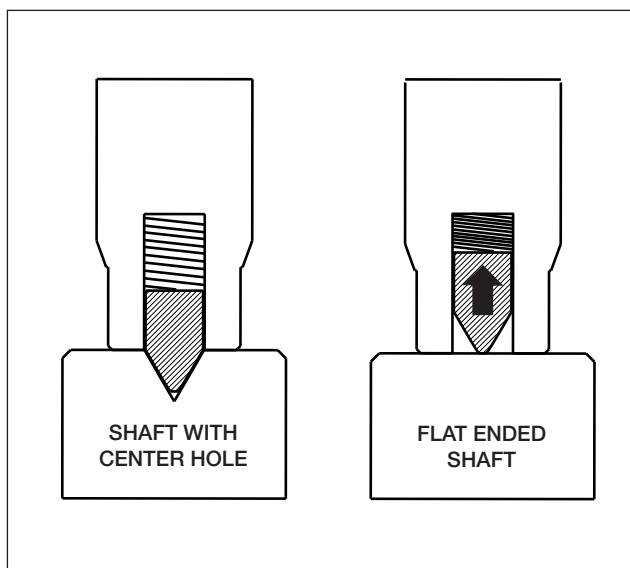

Figure 4, Retractable Point
(Models SGM10 and SGM20)

5.4 Jaw Mounting Positions and Adjusting Rod

- Install each jaw using the lowest mounting holes allowable for the application being performed. This will reduce the amount of jaw and adjusting rod deformation in the event of great force. See Figure 5.

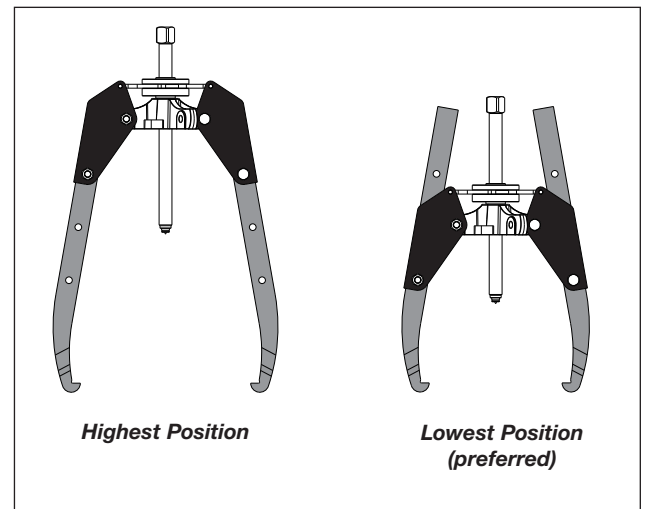

Figure 5, Jaw Mounting Positions (typical)

- As the adjusting rod is turned in the clockwise direction, it protrudes an increased distance below the puller body. The length of the rod that is under load increases, and there is a greater chance that the rod will become bent during puller operation. See Figure 6, Views A, B and C.
- A spacer of appropriate size can be placed in between the tip of the adjusting rod and the end of the shaft. This will reduce the possibility of adjusting rod deformation. The spacer should be a solid steel billet with flat ends. Be certain that the spacer diameter is larger than that of the adjusting rod.
- The amount of adjusting rod protrusion can also be reduced by installing the jaws using the next lowest set of mounting holes.
- Install the jaws using the highest set of mounting holes only if it is necessary to provide additional clearance for large components. See Figure 6, View D.

6.0 OPERATION

6.1 General Puller Use Instructions

- Be sure that the puller adjusting rod is cleaned and greased before use.
- Be sure that the jaws are properly centered on the pulley or other item to be removed.
- Work slowly when operating the puller in order to prevent any sudden or unexpected displacement of parts being removed.
- Never strike the adjusting rod with a hammer or any other object.

6.2 Puller Installation and Operation

NOTICE Before operating any high force tool equipment, it is mandatory that the operator has a full understanding of all instructions and safety precautions included in this manual, and of all applicable local safety regulations and laws. If there are any questions or concerns, contact the Enerpac Technical Service Department or your local Enerpac distributor.

- Assemble the jaws on the puller body. Tighten mounting bolts and nuts.
- Install the puller on the pulley or other part to be removed. See Figure 7 for examples.

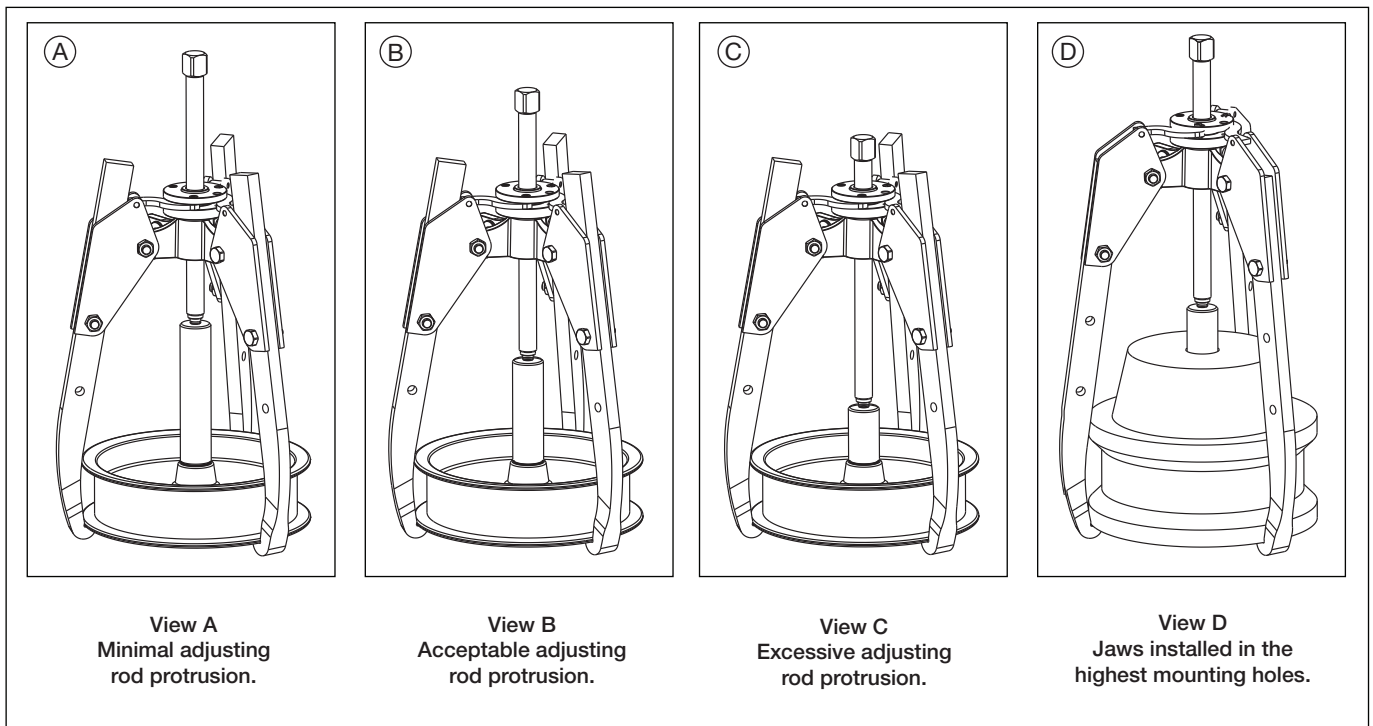

Figure 6, Jaw Mounting Positions and Adjusting Rod Height

- For models SGM01, SGM04 and SGM07, if the end of the shaft is flat, install the point protector between the shaft end and the adjusting rod point. Refer to Section 5.3.
- Rotate the adjusting rod clockwise by hand, until the pointed end of the rod contacts the recessed area of the shaft or of the point protector (if used).
- Using a suitable wrench, slowly turn the adjusting rod to apply force, continuing until the part is removed.

⚠ WARNING Limit applied torque as required to ensure safe operation. Apply force using a hand wrench. NEVER use a powered wrench to turn the adjusting rod. Serious personal injury or death may result if these precautions are not observed.

- During operation, continuously monitor the puller for indications of deformation. If the adjusting rod bends or any jaw deformation is noticed, stop tightening the adjusting rod immediately. See Figure 7.

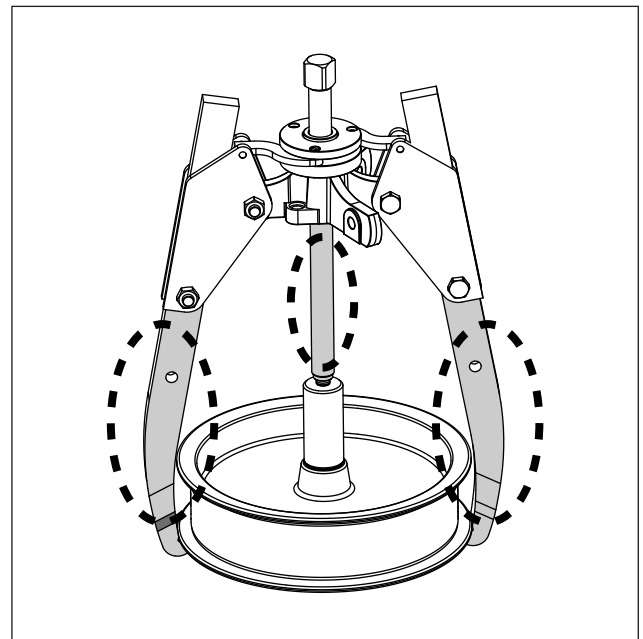

Figure 8, Checking for Deformation

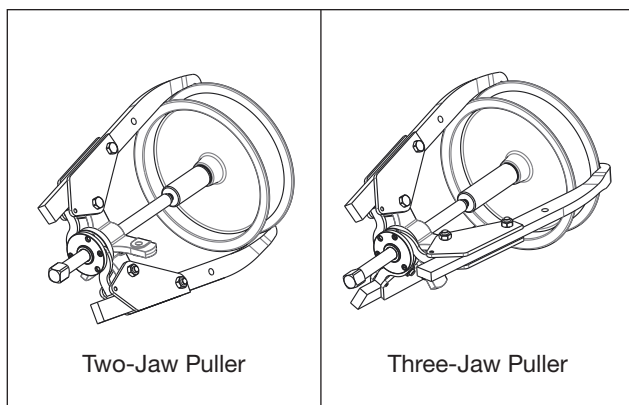

Figure 7, Pulley Removal (typical)

6.3 Inspection, Maintenance and Storage

Maintenance is required when wear or damage is noticed. Periodically inspect all components to detect any problem requiring maintenance or service.

- Periodically check the puller for loose, bent, worn or damaged components. Tighten or replace any such components immediately.
- Keep the puller free of dust and dirt.
- Keep the puller in good condition. Clean and lubricate the puller's adjusting rod and jaws frequently, from top of threaded area to tip, to ensure good operation and long life.
- Store the puller in a clean, dry and secure location.
- If the puller requires repairs, refer to the Enerpac website for the repair parts sheet applicable to your puller model.

NOTICE The puller must only be serviced by a qualified technician. For repair service, contact the Enerpac Authorized Service Center in your area.

7.0 TROUBLESHOOTING

Refer to the troubleshooting guide when diagnosing puller operational problems. Please note that the troubleshooting guide is not all-inclusive, and should be considered only as an aid to help diagnose the most commonly anticipated problems.

For repair service, contact your nearest Enerpac Authorized Service Center.

<i>Troubleshooting Guide, SGM-Series Sync Grip Mechanical Pullers</i>		
Symptom	Possible Cause	Solution
1. Jaws do not move freely or are difficult to move.	Self-centering mechanism corroded or seized.	Inspect self-centering mechanism. If corroded or seized, apply penetrating oil. Dismantle and clean mechanism as required.
2. One jaw moves independently.	Self-centering strap damaged or broken.	Replace self-centering strap. Replace complete self-centering mechanism if needed.
3. Adjusting rod will not turn or requires excessive effort to turn.	a. Corroded threads on adjusting rod or puller body.	If parts are seized, apply penetrating oil. Inspect threads on adjusting rod and cylinder body. Dismantle and clean components as required.
	b. Worn or damaged threads.	Replace adjusting rod and/or puller body as required. Do not use puller if threads are worn or damaged.
	c. Adjusting rod is bent.	Replace adjusting rod. Do not use puller if adjusting rod is bent.

8.0 PRODUCT DATA

8.1 General Specifications and Dimensions

Refer to Section 8.2 for adjusting rod dimensions. Refer to Section 8.3 for jaw dimensions.

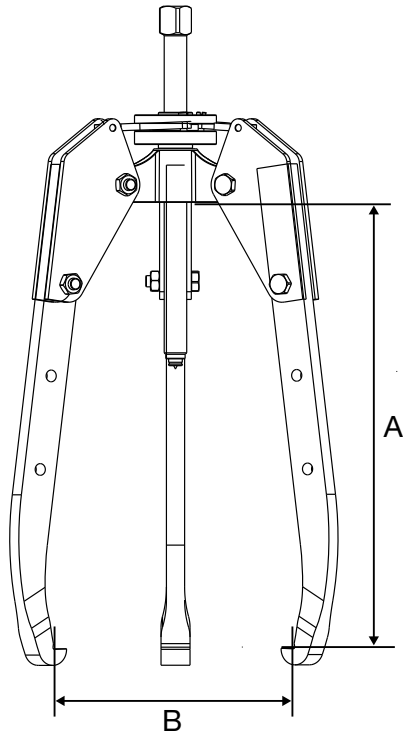

Standard Length Jaws
(all models)

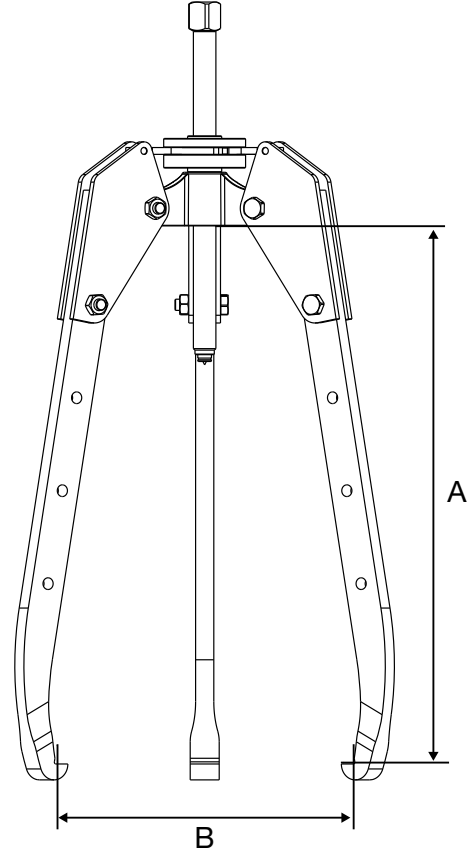

Extended Reach Long Jaws
(Optional Accessory - SGM10 and SGM20 only)

Puller Model No.	Jaw Length	Capacity		Maximum Reach		Maximum Spread		Weight*	
		US Tons	kN	A		B		lb	Kg
				in	mm	in	mm		
SGM01	Std.	1	8.9	4.13	105	4.33	110	1.8	0.8
SGM04	Std.	4	35.6	7.28	185	6.89	175	4.4	2.0
SGM07	Std.	7	62.3	8.86	225	9.45	240	14.3	6.5
SGM10	Std.	10	89.0	16.14	410	13.78	350	32.0	14.5
	Long	10	89.0	19.29	490	15.94	405	35.3	16.0
SGM20	Std.	20	177.9	23.62	600	26.77	680	122.3	55.5
	Long	20	177.9	25.20	640	28.35	720	135.5	61.5

*Approximate weight of assembled puller, including puller body components, adjusting rod and three jaws.

8.2 Specifications and Dimensions - Puller Adjusting Rod

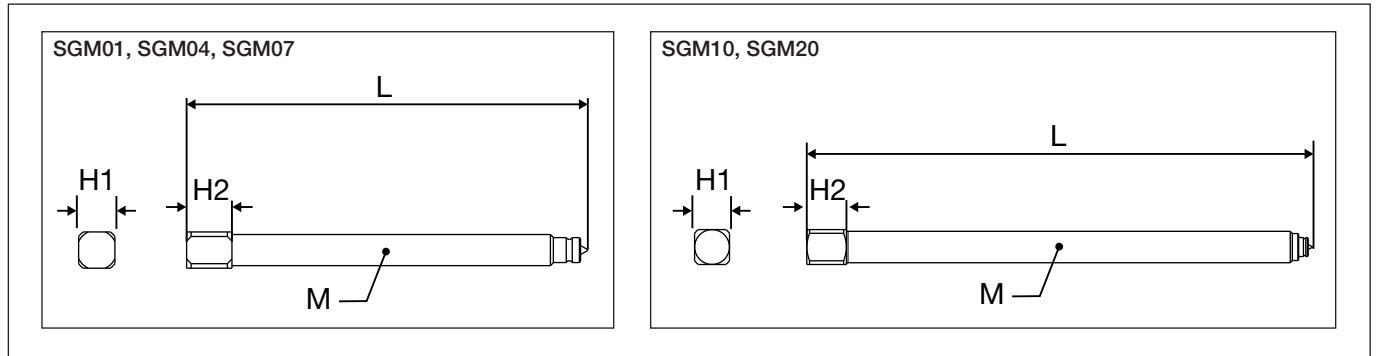

Puller Model No.	Length		Square Size		Square Depth		Thread Size
	L		H1		H2		M
	in	mm	in	mm	in	mm	
SGM01	4.88	124	0.47	12	0.55	14	M10 x 1.0
SGM04	6.97	177	0.63	16	0.79	20	M14 x 1.5
SGM07	9.25	235	0.75	19	0.94	24	M18 x 1.5
SGM10	12.64	321	0.87	22	0.98	25	M20 x 1.5
SGM20	20.08	510	1.38	35	1.50	38	1-3/8" UNF

Note: Models SGM10 and SGM20 are equipped with spring-loaded retractable point.

8.3 Specifications and Dimensions - Puller Jaws

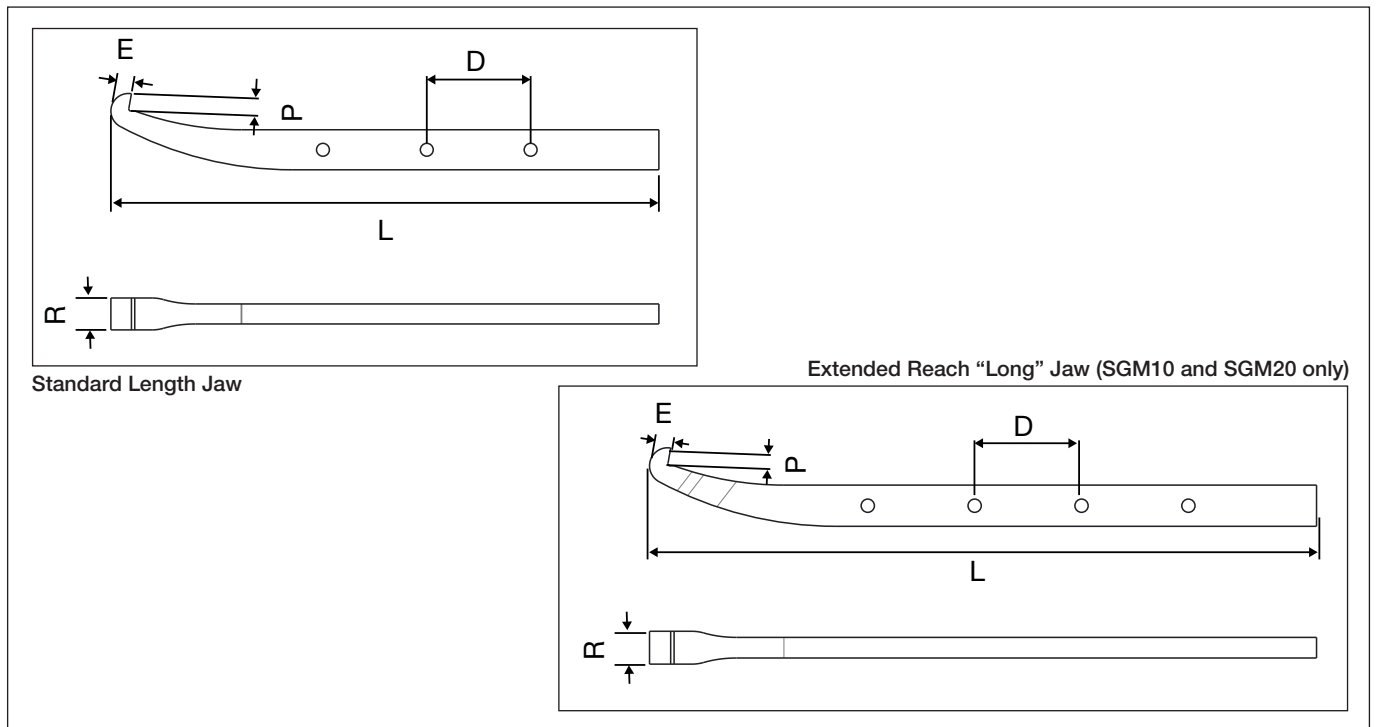

Puller Model No.	Jaw Length	End Surface		Width		Total Thickness		Length		Distance Between Holes	
		P		R		E		L		D	
		in	mm	in	mm	in	mm	in	mm	in	mm
SGM01	Std.	0.28	7	0.30	7.5	0.31	8	5.00	127	0.75	19
SGM04	Std.	0.31	8	0.83	21	0.30	7.5	8.62	219	2.01	51
SGM07	Std.	0.31	8	0.98	25	0.39	10	10.39	264	1.75	44.5
SGM10	Std.	0.59	15	0.98	25	0.49	12.5	17.17	436	3.27	83
	Long	0.59	15	0.98	25	0.49	12.5	20.31	516	3.27	83
SGM20	Std.	0.94	24	1.61	41	0.87	22	27.48	698	4.92	125
	Long	0.94	24	1.61	41	0.87	22	32.40	823	4.92	125

Enerpac Worldwide Locations

◆ e-mail: info@enerpac.com

◆ internet: www.enerpac.com

Australia and New Zealand

Actuant Australia Ltd.
P.O. Box 6867
Wetherhill Park, NSW 1851
Block V Unit 3
Regents Park Estate
391 Park Road
Regents Park NSW 2143
Australia
T +61 287 177 200
F +61 297 438 648
sales-au@enerpac.com

Brazil

Power Packer do Brasil Ltda.
Rua Luiz Lawrie Reid, 548
09930-760 - Diadema (SP) - Brazil
T +55 11 5687 2211
Toll Free: 0800 891 5770
vendasbrasil@enerpac.com

China (Taicang)

Actuant (China) Industries Co. Ltd.
No.6 Nanjing East Road,
Taicang Economic Dep Zone
Jiangsu, China
T +86 0512 5328 7500
F +86 0512 5335 9690
Toll Free: +86 400 885 0369
sales-cn@enerpac.com

France, Switzerland, North Africa and French speaking African countries

ENERPAC
Une division d'Actuant France S.A.S
Zone Orlytech Bâtiment 516
1 allée du commandant Mouchotte
CS 40351
91550 Paray-Vieille-Poste
France
T +33 1 60 13 68 68
F +33 1 69 20 37 50
sales-fr@enerpac.com

Germany and Austria

Actuant GmbH
P.O. Box 300113
D-40401 Düsseldorf
Willstätterstrasse 13
D-40549 Düsseldorf, Germany
T +49 211 471 490
F +49 211 471 49 28
sales-de@enerpac.com

India

Actuant India Private Limited
No. 10, Bellary Road, Sadashivanagar,
Bangalore, Karnataka 560 080
India
T +91 80 3928 9000
info@enerpac.co.in

Italy

ENERPAC S.p.A.
Via Canova 4
20094 Corsico (Milano)
T +39 02 4861 111
F +39 02 4860 1288
sales-it@enerpac.com

Japan

Applied Power Japan LTD KK
Besshocho 85-7
Kita-ku, Saitama-shi 331-0821, Japan
T +81 48 662 4911
F +81 48 662 4955
sales-jp@enerpac.com

Middle East, Egypt and Libya

ENERPAC Middle East FZE
Plot M00737m 1242nd Street
Jebel Ali Free Zone North
P.O. Box 18004, Dubai
United Arab Emirates
T +971 (0)4 8872686
F +971 (0)4 8872687
sales-ua@enerpac.com

Russia

Rep. office Enerpac
Russian Federation
Admirala Makarova Street 8
125212 Moscow, Russia
T +7 495 98090 91
F +7 495 98090 92
sales-ru@enerpac.com

Norway

Sales Office Norway
Unit 524, Nydalsveien 28, 0484 Oslo
P.O. Box 4814, Nydalen 0422 Oslo
Norway
T +47 91 578 300
insidesalesnorway@enerpac.com

Southeast Asia, Hong Kong and Taiwan

Actuant Asia Pte Ltd.
83 Joo Koon Circle
Singapore 629109
T +65 68 63 0611
F +65 64 84 5669
Toll Free: +1800 363 7722
sales-sg@enerpac.com

South Korea

Actuant Korea Ltd.
3Ba 717, Shihwa Industrial Complex
Jungwang-Dong, Shihung-Shi,
Kyunggi-Do
Republic of Korea 429-450
T +82 31 434 4506
F +82 31 434 4507
sales-kr@enerpac.com

Spain and Portugal

ENERPAC SPAIN, S.L.
Avda. Valdelaparra N° 27 3ª - L8
28108 Alcobendas (Madrid), Spain
T +34 91 884 86 06
F +34 91 884 86 11
sales-es@enerpac.com

Sweden, Denmark

Finland and Iceland

Enerpac Scandinavia AB
Kopparlundsvägen 14,
721 30 Västerås
Sweden
T +46 (0) 771 41 50 00
scandinavianinquiries@enerpac.com

The Netherlands, Belgium, Luxembourg, Central and Eastern Europe, Baltic States, Greece, Turkey and CIS countries

ENERPAC B.V.
Galvanistraat 115, 6716 AE Ede
P.O. Box 8097, 6710 AB Ede
The Netherlands
T +31 318 535 911
F +31 318 535 848
sales-nl@enerpac.com

Enerpac Integrated Solutions B.V.

Spinelstraat 15, 7554 TS Hengelo
P.O. Box 421, 7550 AK Hengelo
The Netherlands
T +31 74 242 20 45
F +31 74 243 03 38
integratedsolutions@enerpac.com

South Africa and other English speaking African countries

Enerpac Africa Pty Ltd.
No. 5 Bauhinia Avenue
Cambridge Office Park
Block E
Highveld Techno Park
Centurion 0157
Republic of South Africa
T: +27 12 940 0656
sales-za@enerpac.com

United Kingdom and Ireland

ENERPAC UK Ltd.
5 Coopies Field
Morpeth, Northumberland
NE61 6JR, England
T +44 1670 5010 00
sales-uk@enerpac.com

USA, Latin America and Caribbean

ENERPAC World Headquarters
P.O. Box 3241
Milwaukee WI 53201-3241 USA
N86 W12500 Westbrook Crossing
Menomonee Falls, Wisconsin 53051
T +1 262 293 1600
F +1 262 293 7036
User inquiries:
T +1 800 433 2766
Distributor inquiries/orders:
T +1 800 558 0530
F +1 800 628 0490
Technical inquiries:
techservices@enerpac.com
sales-us@enerpac.com

All Enerpac products are
guaranteed against defects
in workmanship and materials
for as long as you own them.

For the location of your nearest
authorized Enerpac Service Center,
visit us at www.enerpac.com