

# DYNABRADE AIR TOOL MAINTENANCE GUIDE

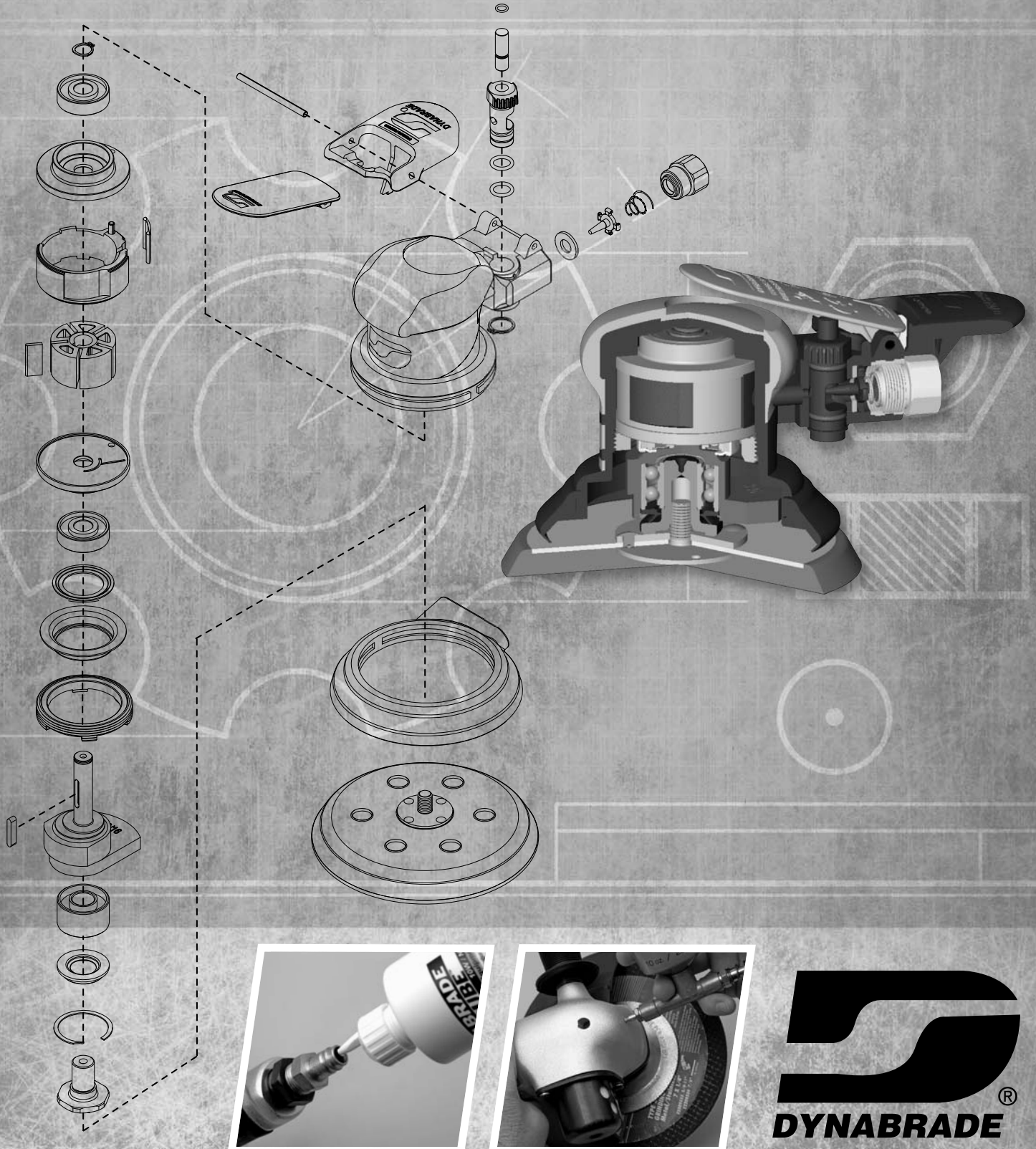

# TABLE OF CONTENTS

|   |           |
|---|-----------|
| <b>SAFETY</b> .....   | pg. 3     |
| Guidelines/ Symbols .....   | pg. 3     |
| <b>COMPRESSED AIR SUPPLY SYSTEM</b> .....                                     | pg. 4-6   |
| Air System Diagram .....  | pg. 4-5   |
| Selecting A Compressor .....  | pg. 5-6   |
| Defining CFM .....  | pg. 6     |
| <b>MAINTAINING ADEQUATE AIR FLOW / AIR SUPPLY HOSES</b> .....                 | pg. 7     |
| <b>AIR PLUGS / COUPLERS</b> .....   | pg. 8     |
| <b>PREVENTATIVE MAINTENANCE</b> .....   | pg. 9     |
| <b>MAINTENANCE ACCESSORIES</b> .....  | pg. 10    |
| Air Tool Lubricants / Dynaswivel® .....                                       | pg. 10    |
| DynaJet In-Line Blow Guns/ Filter-Regulator-Lubricator .....                  | pg. 11    |
| <b>DROP-IN MOTORS / MOTOR TUNE-UP KITS</b> .....                              | pg. 12    |
| <b>AIR TOOL MAINTENANCE REFERENCE</b> .....                                   | pg. 13    |
| Special Repair Tools.....   | pg. 13-15 |
| General Repair Tools .....  | pg. 15-17 |
| <b>PERFORMANCE ASSURANCE</b> .....  | pg. 18-19 |
| <b>MEASUREMENT CONVERSION TABLE<br/>REFERENCE / CONTACT INFORMATION</b> ..... | pg. 20    |

**CAREFULLY READ ALL INSTRUCTIONS BEFORE OPERATING,  
MAINTAINING OR SERVICING ANY POWER TOOL**

**CONTACT YOUR DYNABRADE REPRESENTATIVE FOR PRICING OF PRODUCTS SHOWN IN THIS GUIDE**





# SAFETY GUIDELINES

## For Various Abrasive Power Tools

### ***Safety Booklet included with tool must be read and understood before operating any portable pneumatic tool!***



- This page must be read and understood by operating personnel and safety manager. Protection to operating personnel, as well as adjacent areas, shall be maintained at all times.
- Always comply with: General Industry Safety & Health Regulations ([www.osha.gov](http://www.osha.gov)), EN Standards for Hand Held Non-Electric Power Tools ([www.cen.eu](http://www.cen.eu)), American National Standards Institute ([www.ansi.org](http://www.ansi.org)) and Regional Regulations.
- Additional safety reference materials are available at [Dynabrade.com](http://Dynabrade.com).

### Safety Signal Words

|   |  |
|---|--|
|  | Indicates a hazardous situation that, if not avoided, will result in death or serious injury. This signal word is to be limited to the most extreme situations.  |
|  | Indicates a hazardous situation that, if not avoided, could result in death or serious injury.   |
|  | Indicates a hazardous situation that, if not avoided, could result in minor or moderate injury. It may also be used without the safety alert symbol as an alternative to "NOTICE."   |
|  | Is the preferred signal word to address practices not related to personal injury. The safety alert symbol shall not be used with this signal word. As an alternative to "NOTICE", the word "CAUTION" without the safety alert symbol may be used to indicate a message not related to personal injury. |

### Safety Symbols

Dynabrade Inc. safety labels/symbols follow the guidelines outlined in ISO 3864. In order to help users understand the meaning of the safety labels/symbols, the standard allows the reproducing of the figures and captions below. Some colored symbols are reproduced in this document in grayscale. A complete color version may be found at [Dynabrade.com](http://Dynabrade.com).

|   |   |   |   |   |  |
|---|---|---|---|---|--|
|  | <b>WARNING</b><br>A black graphical symbol inside a yellow triangle with a black triangular band defines a safety sign that indicates a hazard. |  | <b>PROHIBITION</b><br>A black graphical symbol inside a red circular band with a red diagonal bar defines a safety sign that indicates that an action shall not be taken or shall be stopped. |  | <b>MANDATORY ACTION</b><br>A white graphical symbol inside a blue circle defines a safety sign that indicates that an action shall be taken to avoid a hazard. |
|---|---|---|---|---|--|

For consistency Dynabrade Inc. also uses the above symbols and word definitions in collateral material, which includes this Pneumatic Tool Safety Guidelines. For product safety information in Product Manuals, Instructions, and other Collateral Materials, Dynabrade Inc. adheres to ANSI Z535.6-2006.

|   |                                     |   |                                     |   |                     |
|---|-------------------------------------|---|-------------------------------------|---|---------------------|
|  | Refer to Instruction Manual/Booklet |  | Fire Hazard                         |  | Safety Alert        |
|  | Eye Protection Must Be Worn         |  | Explosion Hazard                    |  | Air Hose Hazard     |
|  | Electric Shock Hazard               |  | Hearing Protection Must Be Worn     |  | Entanglement Hazard |
|  | Vibration Hazard                    |  | Respiratory Protection Must Be Worn |  | Crush Hazard        |

# COMPRESSED AIR SUPPLY SYSTEM

## Lubricator Setting

1 Drop/Minute per 20 SCFM

Dynabrade recommends one drop of air lube per minute for each 20 SCFM (566 L/Min)

**Example:** If the tool specifications state 40 SCFM (1,133 L/Min), set the drip rate of your lubricator at 2 drops per min.

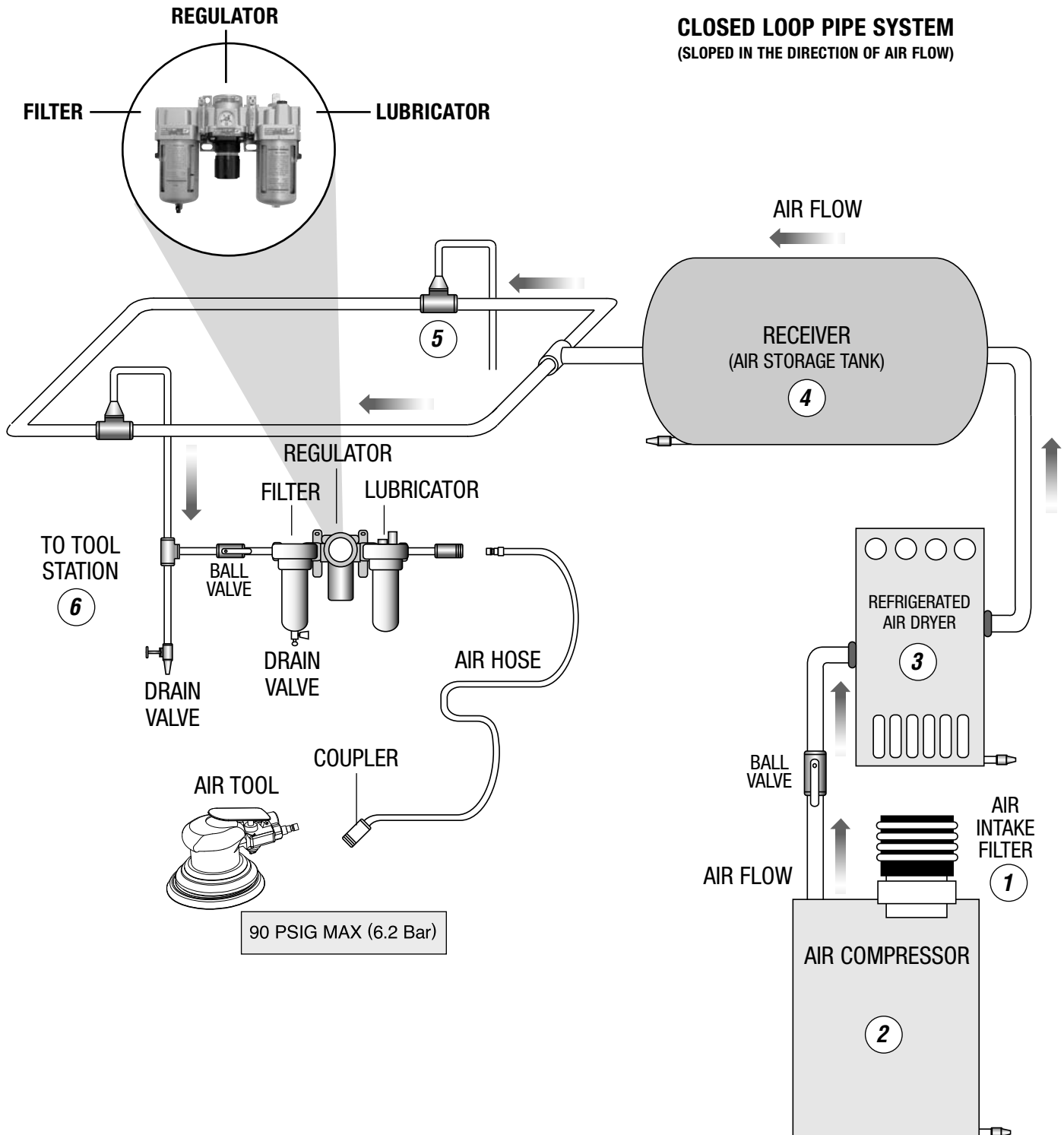

# COMPRESSED AIR SUPPLY SYSTEM (CONT.)

## COMPRESSED AIR SYSTEMS SHOULD INCLUDE THE FOLLOWING:

### 1. AIR INTAKE FILTER

Incoming air must be filtered to remove dust and other contaminants.

### 2. AIR COMPRESSOR

The filtered air is compressed using; a screw, or reciprocating compressor.

### 3. AIR COOLING/DRYING

Air usually contains a significant amount of water vapor. As air is compressed its temperature is dramatically raised, so cooling of the compressed air is required. As the air is cooled, the water vapor condenses and water is removed.

### 4. AIR STORAGE

A tank called an air receiver is placed downstream from the air cooler/dryer. The air receiver reduces demand fluctuations in the compressed air system.

### 5. AIR DISTRIBUTION

A system of pipes and regulators carry compressed air from the compressor to the work areas. This system includes various isolation valves, fluid traps, and provides additional air storage.

### 6. POINT OF USE

At the work area, a feeder pipe with an isolation valve, filter, regulator and lubricator, carry compressed air to a hose that supplies the air powered tool.

#### Filter-Regulator-Lubricator:

Proper air tool maintenance requires delivering the required pressure and volume of clean, lubricated, compressed air to the air motor. Proper use of an air filter-regulator-lubricator will help to protect portable air tools.

The filter helps to prevent water and particulate contaminants from entering the air motor.

The regulator accurately controls air pressure to the tool to further protect moving parts of the air motor.

The lubricator can be set to provide an adequate amount of oil.

This formula can be used to approximate oil drip rate. –  $\frac{\text{Pressure/PSI} \times \text{SCFM}}{1000}$

1000

## SELECTING A COMPRESSOR

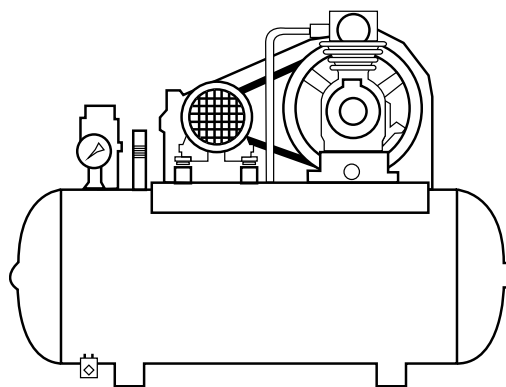

#### A) COMPRESSOR TYPE – Base on your PSIG (Bar) needs

**0 to 80 PSIG (5.5 Bar)**– You may only need a single stage compressor

**80 to 250 PSIG (17.2 Bar)**– You will need a two-stage compressor

Two-stage compressors are recommended when tool usage is continuous.

**Note:** Dynabrade air tools require air pressure of 90 PSIG (6.2 Bar)

#### B) AIR CONSUMPTION – Determine the total demand SCFM (L/Min). List the requirements for all equipment, tools and other air consumption variables (both continuous and intermittent air usage demands).

*continued on next page*

# SELECTING A COMPRESSOR (CONT.)

- C) **COMPRESSOR HORSEPOWER (hp)** – Use the determined total demand SCFM (L/Min) and add approximately 20% for system variables. Add \_\_\_\_\_% for (your) future growth.  
If the above total equals less than 100 SCFM(2,832 L/Min) divide this total by 4 to find the compressor hp.  
If the total is over 100 SCFM(2,832 L/Min) divide by 5 to find the compressor hp.

Example: System requirements = 165 SCFM (4,673 L/Min) @ 100 PSIG (6.9 Bar)

$165 \div 5 = 33$  hp.

Suggested Compressor Size: ~30 to ~40 hp.

- D) **AIR STORAGE TANK SIZE** - As a general rule, the larger the tank (receiver) the better. Use a larger receiver for installations where larger air flows of short duration are expected.

E) **CONTROLS**

Stop-Start – The motor stops when the compressor unloads and starts again when the pressure in the receiver drops. Use a stop-start pressure switch control for a small system. (Compressors up to 15 hp.)

Continuous Run – Equipped with constant pressure control, loading and unloading as the supply of compressed air in the receiver drops or reaches a maximum.

# DEFINING CFM

The term CFM is often confusing and difficult to define. One definition does not satisfy all conditions we encounter when dealing with applications throughout the world.

It is important to understand that air is a compressible fluid. Conditions are dependent on location, time of year, altitude, etc.

Because of these atmospheric variations (air pressure, temperature, and air density) the fluid properties of air are constantly changing.

For example, conditions in Los Angeles, CA, USA, a location at sea level with an atmospheric pressure around 14.69 PSIA., will vary significantly to the conditions that exist in Denver, CO, USA, at an altitude of 5280 feet above sea level, and an atmospheric pressure of around 12.12 PSIA.

For this reason, Dynabrade Inc. adheres to measuring maximum air flow in standard cubic feet per minute (SCFM). NOTICE: ISO Standard: 68°F, 0% relative humidity, 14.5 PSIA (air pressure at sea level).

Standard Cubic Feet per Minute (SCFM) is typically used as a standard reference condition to measure air flow rate under atmospheric pressure at sea level. This is different from measuring Actual Cubit Feet per Minute (ACFM). ACFM is typically used to rate the air compressor system's performance at an actual site's existing air pressure, temperature and humidity.

# MAINTAINING ADEQUATE AIR FLOW

## PREVENT AND ELIMINATE AIR SUPPLY RESTRICTIONS

### Common causes of restriction:

- The air supply hose is too long.
- The inside diameter (i.d.) of the hose is too small.
- The air connections or fittings have an inside diameter that is too small.
- There are too many air connections or fittings being used.
- If an inline filter is being used, the unit may be too small or the filter element may be plugged.
- If an inline regulator is being used, the unit may be too small, not adjusted properly or defective.
- The air supply hose, air fitting, air tool inlet or air tool exhaust may be plugged.
- If the air tool has a speed regulator it may be closed.

## AIR SUPPLY HOSE

- Use the air supply hose with the correct inside diameter as is recommended by the air tool manufacturer.
- Use the shortest air supply hose possible for the task being performed.
- Longer air supply hoses require larger inside diameters.
- Coiled air supply hoses appear much shorter than they actually are. When using a coiled hose, make sure that the inside diameter is large enough to compensate for the length.

## AIR SUPPLY HOSE RECOMMENDED CHART

| Air Motor SCFM<br>(Standard Cubic Feet per Minute) | Hose & Fitting I.D. Required | Recommended Length<br>Air Supply Hose |
|--|------------------------------|---------------------------------------|
| 22 SCFM (623 L/Min)                                | 1/4" (6 mm)                  | 1' - 8' (0.3048 m - 2.44 m)           |
| 28 SCFM (793 L/Min)                                | 3/8" (10 mm)                 | 1' - 25' (0.3048 m - 8.7 m)           |
| 35 SCFM (991 L/Min)                                | 3/8" (10 mm)                 | 1' - 20' (0.3048 m - 6.10 m)          |
| 45 SCFM (1,274 L/Min)                              | 3/8" (10 mm)                 | 1' - 10' (0.3048 m - 3.042 m)         |
| 73 SCFM (2,067 L/Min)                              | 1/2" (15 mm)                 | 1' - 20' (0.3048 m - 6.10 m)          |

## CHOOSE THE CORRECT INSIDE DIAMETER (I.D.) AND LENGTH OF AIR SUPPLY HOSE

**NOTE:** To increase the length of air supply hose it will be necessary to increase the inside diameter of the hose.

# AIR SUPPLY HOSES

## FLEXIBLE AIR SUPPLY HOSES

3/8" I.D. with two male 1/4" NPT fittings. PART NUMBER **11292** - 8 feet (2.44 m) long

1/2" I.D. with one male and one female 1/2" NPT fitting. PART NUMBER **95870** - 5 feet (1.53 m) long

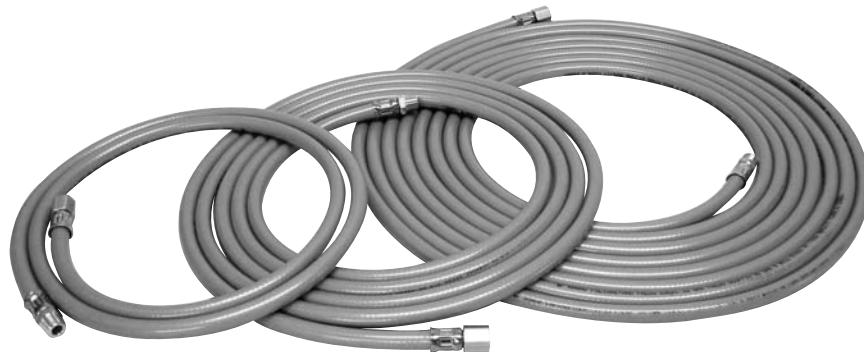

For a complete offering of air line assemblies, reference the Dynabrade Industrial Power Tools, Accessories and Abrasives Catalog or check online: [Dynabrade.com](http://Dynabrade.com)

# AIR PLUGS AND COUPLERS

## PLUGS

COMPARE AIRFLOW SCFM (LPM)

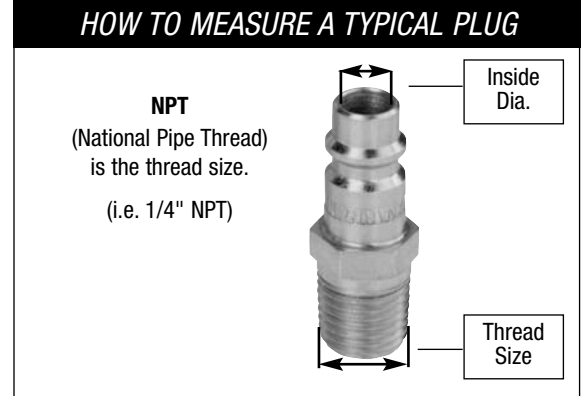
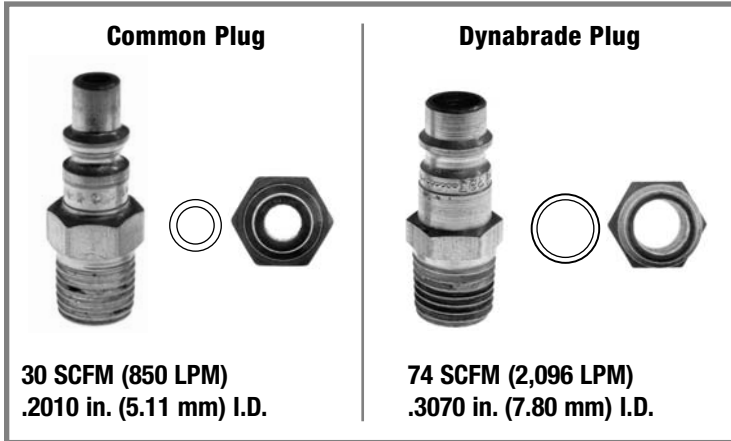

- Dynabrade plugs provide maximum air flow
- Plugs are available in the following sizes: 1/4", 3/8" and 1/2" NPT.

**IMPORTANT:** It is not always advisable to use an air plug and coupler to connect an air tool to the air supply hose. Contaminants can enter the air tool through plug and coupler connections. This often happens when an operator changes to a different tool. The hose and coupler may fall to the floor, or disconnected air tools are left lying exposed in the work area. The exposed ends of the plug and coupler will collect abrasive, grinding, sanding and polishing particles. When the air tool is once again connected to the air supply, these particles are blown into the air motor. When this happens it causes considerable wear to the internal parts of the air motor.

Using a direct thread connection between the air power tool and the air supply hose can reduce the likelihood of contamination entering an air motor at the point where the air connection is made.

## COUPLERS

- Dynabrade couplers provide maximum air flow
- Couplers are available in the following sizes: 1/4", 3/8" and 1/2" NPT.
- Couplers are sold separately as well as in matched assemblies with plugs.
- Dynabrade couplers come in different styles to satisfy every request.

## COUPLER STYLES



For a complete offering of plugs and couplers, reference the Dynabrade Industrial Power Tools, Accessories and Abrasives Catalog or check online: [Dynabrade.com](http://Dynabrade.com)



# PREVENTATIVE MAINTENANCE

---

## ***PROVIDE A GOOD AIR SUPPLY:***

### **1. REDUCE OR ELIMINATE CONDENSATION (WATER VAPOR) FROM THE AIR SUPPLY**

- Water traps and drains
- After-coolers
- Refrigerated air dryer

### **2. PREVENT DEBRIS FROM ENTERING THE AIR MOTOR**

- Filter the air.
- Keep the air inlet connections, plugs and couplers clean, free of dust and debris.
- Keep exhaust mufflers and elements in place. Muffler elements provide a barrier that will prevent dust from being pulled into the air motor.
- Do not use compressed air to blow-off the tool, this could force debris into bearings.

### **3. LUBRICATE THE AIR MOTOR**

- Use an automatic lubricator to supply the correct weight and amount of air motor oil.
- Supply the air motor oil manually, directly into the air inlet. Apply 2-3 drops throughout the day.
  - i.e., start-up
  - mid-morning
  - lunch
  - mid-afternoon
  - end of the day

---

## ***ELIMINATE ANY BLOCKAGE OF AIRFLOW, IN OR OUT:***

### **1. KEEP THE TOOL'S AIR INLET CLEAR OF ANY DEBRIS**

### **2. CLEAN OR REPLACE EXHAUST MUFFLER ELEMENTS AS NEEDED**

---

## ***LUBRICATE GEARS, SLEEVES, BEARINGS AND SLIDERS***

### **1. USE THE MANUFACTURER'S SPECIFIED LUBRICANT**

- Apply the suggested amount at the recommended interval.  
**Note:** This is usually found in technical support literature, i.e., tool manuals, parts pages, etc.
- 

## ***USE THE TOOL, ACCESSORY OR RELATED PRODUCT AS SPECIFIED BY DYNABRADE, INC.***

### **1. ADHERE TO THE SPECIFIED MAXIMUM OPERATING AIR PRESSURE**

### **2. ADHERE TO THE SPECIFIED MAXIMUM OPERATING RPM FOR ALL TOOLS AND ACCESSORIES**

- i.e., grinding wheels
  - mounted points
  - cut-off wheels
  - sanding discs
  - burrs
  - back-up pads, etc.
-

# MAINTENANCE ACCESSORIES

## Air Tool Lubricants and Dynaswivel®



### Dynabrade Air Lube (10W/NR)

- Formulated for pneumatic equipment.
- Absorbs up to 10% of its weight in water.
- Prevents rust and formation of gum/sludge for longer tool operation with greater power and less downtime.

**95821**  
4 oz. (118 ml)

**95843**  
1 gal. (3.8 l)

**95842**  
1 pt. (473 ml)



### 95848 Gear Oil

2.5 oz. (74 ml) tube

- Formulated for geared tools utilizing a wick-type lubrication system.
- Failure to lubricate will cause premature gear failure.



### Grease

- Multi-purpose grease for all types of bearings, cams and gears.
- High film strength; excellent resistance to water, steam, etc.
- Workable range: 0°F (-17°C) to 300°F (148°C).

**95542**  
10 oz. (283.5 g) tube



### 95541 Push-Type Lubricant Gun

- One-hand operation
- Can be used with Grease or Gear Oil

*Note: Have a dedicated gun for each type of lubricant.*

## Dynaswivel®

- The Dynaswivel® is a "universal-joint" that connects portable air tools to an air line.
- It improves tool maneuverability, minimizes operator fatigue and extends hose life.
- Patented; works great on air tools.
- SWIVELS 360° AT TWO LOCATIONS which allows air hose to drop straight to the floor, no matter how the tool is held.



### 94300

- Air flow: up to 33 SCFM (935 LPM) MAXIMUM.
- Non-marring, lightweight, composite construction.
- Many other configurations available.

## Airline Test Gauge

- Use to test air pressure at selected areas of an air supply system. Test at the tool, to see specific pressure.
- Comes complete with brass "T" connector, quick disconnect coupler and a round pressure gauge.

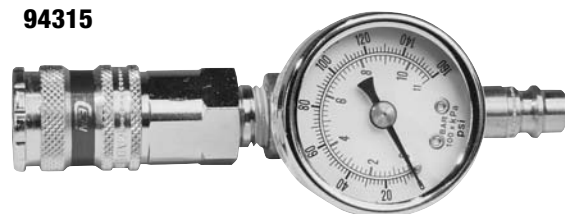

### 94315

# DYNAJET IN-LINE BLOW GUN

## Clean Off Work Surfaces Without Disconnecting

- Only connect once... permanently mounts between coupler and air hose to purge air line of water and contaminants before starting up air tools.
- Durable aluminum construction, weighs only 2 oz. (0.06 kg).

### Part No. 94467 Safety Tip Design

- Reduces line pressure down to 30 PSIG (2 Bar).
- Meets O.S.H.A. requirements of special relief hole in nozzle, which limits pressure to 30 PSIG (2 Bar) when dead-ended and used on an air line of 150 PSIG (10.3 Bar) or less.
- 10.3 Bar (150 PSIG) maximum



94467

| Part Number | Thread Size     | Weight  | Recommended Air Flow Range SCFM (L/Min) |
|-------------|-----------------|---------|---|
| 94467       | 1/4" Female NPT | 0.06 kg | up to 35 SCFM (991 L/Min)               |

### Proper Installation for DynaJet Blow Gun Connection

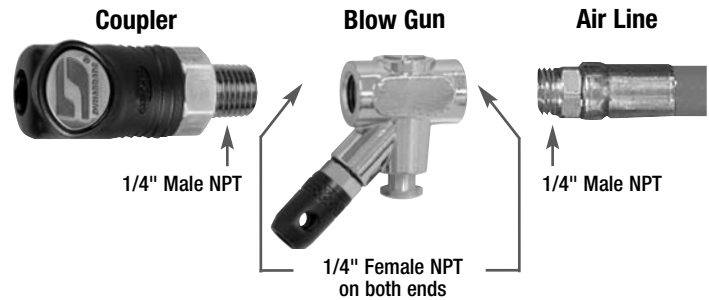

# FILTER-REGULATOR-LUBRICATOR

## Cost-Effective Maintenance for Air Supply Systems

### Filter-Regulator-Lubricator

- Unit has modular connections with mounting brackets for easy installation.

| Part Number | Air Inlet Thread |
|-------------|------------------|
| 10681       | 1/2" NPT         |



10681

### Filter-Regulator

- Unit has modular connections with mounting brackets for easy installation.

| Part Number | Air Inlet Thread |
|-------------|------------------|
| 10677       | 1/2" NPT         |



10677

### Regulator-Lubricator

- Unit has modular connections with mounting brackets for easy installation.

| Part Number | Air Inlet Thread |
|-------------|------------------|
| 10679       | 1/2" NPT         |



10679

### FRL Flow Characteristics

| Air Flow SCFM (L/Min) | Pressure Drop Across FRL PSI (Bar) |
|-----------------------|------------------------------------|
| 15 (425)              | 2.0 (.14)                          |
| 30 (850)              | 3.0 (.21)                          |
| 45 (1,274)            | 6.0 (.41)                          |
| 60 (1,699)            | 7.0 (.48)                          |
| 75 (2,124)            | 8.0 (.55)                          |

### Filter

- Five-micron filter element is standard.
- Manual push-button drain easily discharges contaminants.

| Part Number | Air Inlet Thread |
|-------------|------------------|
| 10671       | 1/2" NPT         |



10671

### Regulator

- Compensation built into unit responds faster to changes in incoming pressure and flow.
- Built-in PSI pressure dial gauge.

| Part Number | Air Inlet Thread |
|-------------|------------------|
| 10673       | 1/2" NPT         |



10673

### Lubricator

- Built-in check valve permits tool to be filled with oil without having to turn off air pressure.
- Adjustable oil drop to meter amount of oil into air system.

| Part Number | Air Inlet Thread |
|-------------|------------------|
| 10675       | 1/2" NPT         |



10675

**Each unit includes two bushings for easy conversion to 3/8" NPT.**

# DROP-IN MOTORS/TUNE-UP KITS



Tune-Up Kit



Drop-In Motor

- Drop-In Motors are complete replacement air motor assemblies.
- Tune-Up Kits contain assorted and high wear replacement parts.

To view a complete offering, go to [Dynabrade.com](http://Dynabrade.com)

---

## GUIDELINES FOR INSTALLING A DROP-IN MOTOR

Installing a Drop-In Motor is relatively simple to perform. However, there are some necessary steps to follow to be successful.

- 1) Before attempting the installation of a drop-in-motor, review and understand the specific power tool “Disassembly and Assembly Instructions”.  
**Note: Though a technician is not disassembling every component, it is important to use correct techniques when removing and installing an air motor assembly.**

Before proceeding, have the necessary Special Repair Tools to remove or install the motor.

**Note: View last page of tool manual for a list of available Special Repair Tools.**

- 2) Remove used air motor.
- 3) Remove old muffler elements.
- 4) Clean the motor housing, air inlet and exhaust passages before installing the new air motor assembly.
- 5) Install new muffler elements.
- 6) Correctly line-up air motor assembly with the inside of motor housing. Install motor.
- 7) Follow all primer/adhesive, and torque specifications for fastening the motor assembly into the housing.  
**Note: Allow 30 minutes for adhesives to cure before running motor.**
- 8) With new motor properly fasten in housing, place three drops of 10Wt. non-detergent air motor oil into air inlet. Connect to air supply and test motor. Use a tachometer to check work spindle RPM.  
**Important: Verify correct maximum free speed.**

- Drop-in Air Motor Installation Completed

---

## TUNE-UP KIT SUGGESTION

Search the Dynabrade website under Repair Tutorials, or use the model number of the tool. Refer to the last page of the tool manual/parts page for Tune-Up Kit information.

# AIR TOOL MAINTENANCE REFERENCE

## Special Repair Tools Designed by Dynabrade

| <b>Repair Collars &amp; Fixtures</b> <i>Used to protect tool during servicing.</i> |          |  |
|--|----------|--|
| Item   | Part No. | Description  |
| 1  | 96399    | .4 hp Motor / Valve Housing (2012 Design)                          |
| 2  | 96402    | .4 hp Motor / Valve Housing (2009 to 2012 Design)                  |
| 3  | 96461    | .4 hp Motor / Valve Housing, 7° Motor Housing, Right Angle Housing |
| 4  | 51989    | 1 hp Motor / Valve Housing, 1.3 hp Valve Housing                   |
| 5  | 57092    | Palm & Two-Hand, Dynorbital / Gear-Driven / Dynalocke              |

| <b>Lock Ring/ Nut Wrenches</b> <i>For removal &amp; installation of motors, spindles &amp; plugs.</i> |          |  |
|---|----------|--|
| Item  | Part No. | Description  |
| 6   | 50971    | .4, .5, .7, & 1 hp Motors as specified   |
| 7   | 56058    | Palm & Two-Hand, Dynorbital® / DynaLocke®  |
| 8   | 56599    | (formerly 96337) 5", 6" & 8" Two-Hand Gear-Driven / Use with composite housing.  |
| 9   | 94598    | 100 K Pencil Grinder   |
| 10  | 94605    | 35, 50, 60 K Pencil Grinder  |
| 11  | 94607    | QCK-Change Pencil Grinder  |
| 12  | 95900    | .5 & .7 hp Steel Housing Die Grinders (Regulator Plug)                           |
| 13  | 96165    | Mini-Angle Head  |
| 14  | 96393    | .4 hp Motor / Valve Housing (2012 Design)  |
| 15  | 96460    | .4 hp Valve / Motor Housing (34 mm Lock Nut)                                     |
| 16  | 96479    | Retainer Wrench / Pencil Grinder (Use for all Models except, Wrenchless Collet.) |
| 17  | 97782    | 1 hp Right Angle, Mini-Angle Head, 1.3 hp Right Angle                            |

| <b>Gear/ Plate/ Carrier/ Housing; Disassembly &amp; Assembly Tools</b> |          |  |
|--|----------|--|
| Item   | Part No. | Description  |
| 18   | 96181    | Pinion Wrench 8" (203 mm) Two-Hand Gear-Driven Sander    |
| 19   | 96182    | Front Plate Tool 8" (203 mm) Two-Hand Gear-Driven Sander |
| 20   | 53698    | Carrier Tool 1 hp (2-Flats)                              |

| <b>Bearing Removal Tools</b> <i>Used to remove bearings</i> |          |   |
|---|----------|---|
| Item  | Part No. | Description                               |
| 21  | 96210    | 02650, 02696 Bearings (5 mm Bearing I.D.) |
| 22  | 96211    | 01015, 02648 Bearings (6 mm Bearing I.D.) |
| 23  | 96212    | 11016 Bearing (6.35 mm Bearing I.D.)      |
| 24  | 96213    | 02649 Bearing (8 mm Bearing I.D.)         |
| 25  | 96214    | 01007 Bearing (10 mm Bearing I.D.)        |

# AIR TOOL MAINTENANCE REFERENCE (CONT.)

## Bearing Press Tools *Used to install bearings.*

| Item | Part No. | Description   |
|------|----------|---|
| 26   | 96216    | 02650, Bearing  |
| 27   | 96239    | 02651, 56052, 11831, 54520 Bearings                         |
| 28   | 96240    | 02649, 12153 Bearings                                       |
| 29   | 96241    | 01015, 12152 Bearings                                       |
| 30   | 96242    | 02696, 12151, 12058, 12078 Bearings                         |
| 31   | 96243    | 11016, 02648, 02057 Bearings                                |
| 32   | 96244    | 01007, 01206 Bearings                                       |
| 33   | 96418    | 51651, 51686 Pencil Grinder Bearings                        |
| 34   | 96419    | 51544, 51685 Pencil Grinder Bearings, 51078 Bearing         |
| 35   | 57091    | 5", 6", 8" All Dynorbital® and Two-Hand Gear-Driven Sanders |

## Bearing and Gear Pullers *Used to remove bearings and gears.*

| Item | Part No. | Description   |
|------|----------|---|
| 36   | 56056    | Bearing Puller / 56052 Bearing  |
| 37   | 57099    | Bearing Puller / 56052 Bearing; Use if the bearing remains in the motor shaft balancer. |

## Collars & Fixtures *Used for holding motor and gear assemblies during disassembly or assembly.*

| Item | Part No. | Description  |
|------|----------|--|
| 38   | 96245    | Machined Size .992 I.D. / Dynadie                        |
| 39   | 96246    | Machined Size 1.028 I.D. / .4 hp (Mini-Dynaflex® II)     |
| 40   | 96247    | Mini-Angle Head  |
| 41   | 96248    | Machined Size 1.390 I.D. / Ring Gear .7 hp Dynastraight® |
| 42   | 96208    | Machined Size 1.50 I.D. / 1.3 hp Motor                   |
| 43   | 96249    | Machined Size 1.980 I.D. / Dynorbital® Supreme Sander    |
| 44   | 96250    | Machined Size 2.290 I.D. / 2.0 hp Right-Angle Tools      |
| 45   | 96209    | Motor Clamp; 1 hp  |
| 46   | 96231    | Tool Plate / Use with 96232 Arbor Press.                 |

## Assorted Special Pencil Grinder Repair Tools

| Item | Part No. | Description  |
|------|----------|--|
| 47   | 51694    | Shaft Lock Pin (All Pencil Grinders except Quick-Change)               |
| 48   | 94999    | Air Bushing Removal Tool (35, 50, 60 K & Quick-Change Pencil Grinders) |
| 49   | 96408    | Motor Top Plate Wrench (All Pencil Grinders except Quick-Change)       |
| 50   | 96483    | Bullet (Use for installing Grip on Pencil Grinders)                    |
| 51   | 96486    | Collet Insert Removal Tool (All Pencil Grinders except Quick-Change)   |

# AIR TOOL MAINTENANCE REFERENCE (CONT.)

## Arbor Press *Used for disassembly/ assembly*

| Item | Part No. | Description                                       |
|------|----------|---|
| 52   | 96232    | Arbor Press (# 2)                                 |
| 53   | 96230    | Press Ram (General purpose non-marring brass ram) |

## Special Repair Tool Kits

| Item | Part No. | Description   |
|------|----------|---|
| 54   | 11270    | Original Dynafite® with screw-in motor / Use to replace contact and idler wheel components.       |
| 55   | 11288    | Dynafite® with cam-lock motor / Use to replace contact and idler wheel components.                |
| 56   | 57098    | Dynorbital® Supreme and Spirit Sander Repair Kit / Use for Supreme and Spirit models.             |
| 57   | 57260    | 5", 6" Two-Hand Dynorbital® and DynaLocke® / Use with composite housing models.                   |
| 58   | 57325    | 8" Two-Hand Dynorbital® / Use for composite and aluminum housing models.                          |
| 59   | 57525    | Mini-Dynorbital® / Use for composite housing models. (Mdl's 57500, 57501, 57502, 57503)           |
| 60   | 96283    | 5", 6", 8" Two-Hand Gear-Driven / Use for composite housing models.                               |
| 61   | 96405    | Finesse-it, Two-Step Tools / Use for Mdl's 57240(45), 57125, 57126, 57500, 57502 & Supreme/Spirit |
| 62   | 56077    | Lightweight Palm-Style Dynorbital® / Use for aluminum housing models.                             |
| 63   | 56577    | Mini-Lightweight Palm-Style Dynorbital® / Use for aluminum housing models.                        |

## General Repair Tools *Wrenches: Open End*

| Item | Part No. | Description   |
|------|----------|---|
| 64   | 96314    | 4 mm Open End / Dynadie III                             |
| 65   | 95731    | 8 mm Open End / Pencil Grinder                          |
| 66   | 96076    | 12 mm Open End  |
| 67   | 95262    | 14 mm Open End  |
| 68   | 96453    | 16 mm Open End  |
| 69   | 95263    | 17 mm Open End  |
| 70   | 95281    | 19 mm Open End  |
| 71   | 95823    | 21 mm Open End  |
| 72   | 95304    | 24 mm Open End  |
| 73   | 50679    | 26 mm Open End  |
| 74   | 59293    | 26 mm Offset Open End / 3" HiVac Dynorbital Spirit      |
| 75   | 95987    | 5/16" Open End  |
| 76   | 96031    | 7/16" Open End  |
| 77   | 96032    | 11/16" Open End   |
| 78   | 95176    | 3/4" Open End   |
| 79   | 98277    | 1-3/8" Open End   |
| 80   | 11278    | 1-1/2" Open End / Original Dynafite with screw-in motor |
| 81   | 98283    | 1-5/8" Open End   |

# AIR TOOL MAINTENANCE REFERENCE (CONT.)

| Hex Key Wrenches |          |                |
|------------------|----------|----------------|
| Item             | Part No. | Description    |
| 82               | 95251    | 1.5 mm Hex Key |
| 83               | 96401    | 2 mm Hex Key   |
| 84               | 95252    | 2.5 mm Hex Key |
| 85               | 95266    | 3 mm Hex Key   |
| 86               | 95331    | 4 mm Hex Key   |
| 87               | 96034    | 12 mm Hex Key  |
| 88               | 96215    | 15 mm Hex Key  |
| 89               | 95050    | 5/64" Hex Key  |
| 90               | 95052    | 3/32" Hex Key  |
| 91               | 95048    | 1/8" Hex Key   |
| 92               | 95049    | 3/16" Hex Key  |
| 93               | 95134    | 9/64" Hex Key  |
| 94               | 95303    | 1/4" Hex Key   |
| 95               | 95521    | 5/16" Hex Key  |
| 96               | 95051    | 3/8" Hex Key   |

| Pin Style Spanner Wrenches |          |   |              |             |
|----------------------------|----------|---|--------------|-------------|
| Item                       | Part No. | Description                                   | Cntr/ Cntr   | Pin Dia.    |
| 97                         | 96347    | Adjustable-Face                               | 10 to 100 mm | 2.9 mm      |
| 98                         | 96148    | Fixed-Face / Mdl.# 50370                      | 24 mm        | 3 mm        |
| 99                         | 94925    | Fixed-Face / Mdl.# 50302, 50306, 52620, 52625 | 32 mm        | 4 mm        |
| 100                        | 96348    | Adjustable-Face                               | 10 to 100 mm | 5.8 mm      |
| 101                        | 96507    | Fixed-Face / Mdl.# 52515                      | 1-1/16"      | 1/8"        |
| 102                        | 95267    | Fixed-Face / Mdl.# 50343                      | 5/8"         | 1/8"        |
| 103                        | 95270    | Fixed-Face / Mdl.# 52700                      | 1"           | 1/8" Square |
| 104                        | 96318    | Adjustable-Face / Mdl.# 50273                 | 5/8" to 2"   | 5/32"       |
| 105                        | 96038    | Fixed-Face                                    | 1-9/32"      | 1/4"        |
| 106                        | 97787    | Pin/Hook Style (Adjustable)                   | 3/4" to 2"   | 1/8"        |

| Generic Hand Tools |          |   |
|--------------------|----------|---|
| Item               | Part No. | Description                                       |
| 107                | 96341    | Inch Folding Hex Key Set (5/64" to 1/4")          |
| 108                | 96342    | Metric Folding Hex Key Set (1.5 mm to 8 mm)       |
| 109                | 96343    | Internal / External Retaining Ring Pliers         |
| 110                | 96344    | 3/32" Dia. Pilot Punch (Use to remove roll pins.) |
| 111                | 96345    | 15/16" Bearing Separator                          |
| 112                | 96346    | 2" Bearing Separator                              |



# AIR TOOL MAINTENANCE REFERENCE (CONT.)

| <b>Generic Hand Tools (cont.)</b> |                 |   |
|-----------------------------------|-----------------|---|
| <b>Item</b>                       | <b>Part No.</b> | <b>Description</b>  |
| 113                               | 96349           | Small Torque Wrench (30-150 in. lbs.)   |
| 114                               | 96350           | Large Torque Wrench (100-1000 in. lbs.)   |
| 115                               | 96351           | Bench Vise (4" Jaw)   |
| 116                               | 96352           | 4" (102 mm) Soft Jaw Caps (Bronze)  |
| 117                               | 96353           | (8 piece) Drive Pin Punch Set; 1/16", 3/32", 1/8", 5/32", 3/16", 7/32", 1/4", 5/16"   |
| 118                               | 96354           | Feeler Gauges (.0015 to .025)   |
| 119                               | 96355           | Small Phillips Screwdriver  |
| 120                               | 96356           | Large Phillips Screwdriver  |
| 121                               | 96357           | Groove Pliers (Channel Lock Style)  |
| 122                               | 96358           | Standard Pliers (slip-joint style)  |
| 123                               | 96359           | Needle Nose Pliers  |
| 124                               | 96360           | 10" Adjustable Wrench (Crescent Style)  |
| 125                               | 96338           | 11" Wide-Opening Adjustable Wrench; 3" (76 mm) jaw opening                            |
| 126                               | 96361           | 3/8" Drive, Ratchet (includes metric and English socket set)                          |
| 127                               | 96362           | 3/8" Drive, Breaker Bar; 10" (254 mm) long flex handle                                |
| 128                               | 96363           | Small Slotted Screwdriver   |
| 129                               | 96364           | Large Slotted Screwdriver   |
| 130                               | 96365           | 3/8" to 1/4" Drive, Socket Adapter  |
| 131                               | 96366           | 12 oz. Soft Hammer  |
| 132                               | 96367           | 8 oz. Ball Peen Hammer  |
| 133                               | 96368           | Electronic Tachometer   |
| 134                               | 96373           | 11/16" Deep Socket  |
| 135                               | 94315           | Air Pressure Test Gauge / Use to check air supply pressure                            |
| 136                               | 80025           | Load Cell / Used to measure the performance of various finishing air tools under load |
| 137                               | 80030           | Test Tool Kit / Includes: 80025, 94315, 95842, and 96368                              |

| <b>Parts Pages, Forms, Adhesive</b> |                 |                                     |
|-------------------------------------|-----------------|-------------------------------------|
| <b>Item</b>                         | <b>Part No.</b> | <b>Description</b>                  |
| 138                                 | 96369           | Liquid Thread Locker (50 ml bottle) |

# PERFORMANCE ASSURANCE

## Air Tool And Air System Inspection/Diagnosis

### AIR TOOL INSPECTION

- Inspect the air tool.

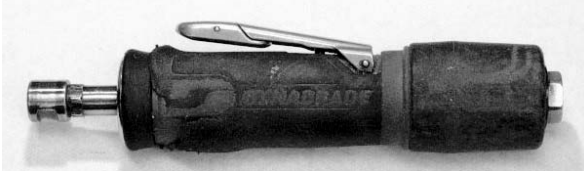

- Is the tool's air inlet clean?

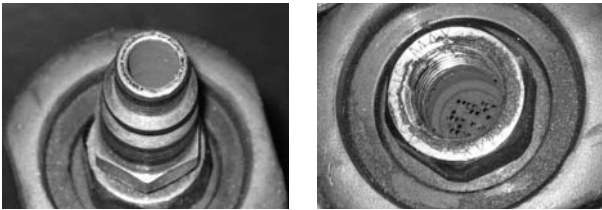

- Is the tool's exhaust (muffler/silencer) clean?



- Has the motor been oiled?

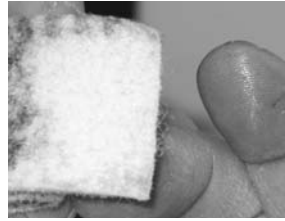

This silencer shows evidence of oil.

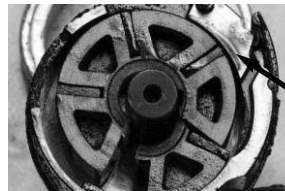

This air motor received "Last-Rites Oil." Notice, the puddle of oil appears clean.

- Can the tool's spindle be turned by hand?



"The spindle won't turn."

This usually indicates broken vanes.

Generally, broken vanes indicate that the motor has not been oiled regularly.

### AIR SYSTEM CHECK

#### Tachometer

- Affix a 1/2" (12 mm) square piece of reflective tape to the tool's spindle or pad.
- Aim the Laser Pointer at the reflective tape and run the tool. (Operational distance: 2"/50 mm to 20"/500 mm)
- Read RPM. (Notice: Refer to User's Manual for more detailed instructions.)

#### PSI Gauge

- Connect Air Gauge and air supply hose to the air inlet of the tool.
- Run the tool and adjust air supply pressure to 90 PSIG (6.2 Bar).

#### Condition of Coupler and Plug

- Check for wear or damage to coupler and/or plug.
- Can the I.D. of the plug supply enough air to the tool?

#### Condition of Air Hose

- Check to see if the hose is frayed or cracked? (see "Cost of an Air Hose Leak" on reverse side)
- What is the length of the hose?
- Match length and I.D. of hose to air requirement of tool.
- Is there a hose reel?

#### Condition of Air Hose (Continued)

- How many coupler connections exist from the drop to the workbench?
- Are there any "T's" or a manifold at the workbench?
- How can Dynaswivel® prolong the life of the hose?



#### Filter-Regulator-Lubricator

- FRL – is it present? If yes, is it working?
- Filled with oil? Set for proper lubrication?
- What type of oil? (Weight, Non-detergent vs. Detergent – Notice: Non-detergent oils contain little to no solvents. Air Tool Oils with "conditioner" usually contain solvents. Example: Both Marvel® Air Tool Oil and Marvel® Mystery Oil contain mineral spirits, a common solvent used as paint thinner.)
- Are there reducer bushings being used to connect the air supply to the FRL?
- What size is the fitting connecting the FRL to the air line that is supplying the air to the workbench?
- Are there any "T's" or manifolds coming directly off the FRL?
- What material is the pipe that is carrying the air supply? Black Iron?

# PERFORMANCE ASSURANCE (CONT.)

## Air Supply Hose Recommendations

| Air Motor SCFM         | Hose and Fitting I.D. | Recommended Length |
|------------------------|-----------------------|--------------------|
| <b>22</b> (623 L/Min)  | <b>1/4"</b>           | <b>1' - 8'</b>     |
| <b>28</b> (793 L/Min)  | <b>3/8"</b>           | <b>1' - 25'</b>    |
| <b>35</b> (991 L/Min)  | <b>3/8"</b>           | <b>1' - 20'</b>    |
| <b>45</b> (1274 L/Min) | <b>3/8"</b>           | <b>1' - 10'</b>    |
| <b>73</b> (2067 L/Min) | <b>1/2"</b>           | <b>1' - 20'</b>    |

## RANDOM ORBITAL SANDER SWIRL-FREE CHECKLIST

### Equipment Check:

#### Random Orbital Sander

- 90 PSIG (6.2 Bar) is the required operating air supply pressure.** Check the air pressure at the sander while it is running. Note: Promote the use of Dynabrade maximum flow plugs and couplers to ensure proper airflow.
- Confirm that the tool is running at the rated "Free Speed" RPM.** On an average a 10,000 RPM non-vacuum sander will run at 9,500 RPM; a 12,000 RPM non-vacuum sander will run at 11,500 RPM. A vacuum sander normally runs slightly slower.
- Inspect the balancer bearing (pad bearing).** Remove the back-up pad and rotate the balancer bearing shaft while holding the counterbalance stationary. The balancer shaft should turn freely.



#### Back-Up Pad

- Inspect the face of the sanding pad.** The pad must be flat and smooth, without any defects. Check if they are using a Dynabrade back-up pad that is "weight-mated" to the sander. Using another pad can make the sander vibrate excessively and lead to an unacceptable finish.

### Sanding Techniques:

- Always START the sander ON the surface, and STOP the sander OFF the surface.**
- When sanding keep the sander, and pad FLAT on the surface.** Important: Do not exert heavy downward force on the sander. Apply enough downward force to keep the back-up pad and abrasive flat on the surface allowing the back-up pad to orbit freely over the surface.

### Sanding Techniques (Continued)

- Follow a set pattern when sanding.** It is suggested to pass over the surface following a "North, South, East, West" pattern (see below), overlapping each pass 1/4 the diameter of the back-up pad and abrasive.

This insures that the previous scratches are removed and that a uniform finish is achieved. Two "patterns" per sanding step are recommended.

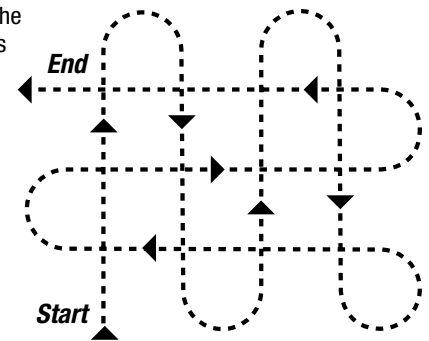

- Frequently inspect abrasive for tears, folds, or build-up.** When changing abrasive to proceed to the next sanding step, first inspect the condition of the abrasive that is on the sander. If any defects are noticed in that abrasive, remove it and install another piece of the same grain and sand the work surface again before proceeding on to the next sanding step.
- Always clear away sanding dust and abrasive debris before progressing to the next sanding step with a finer "grit" abrasive.**

## THE COST OF AN AIR HOSE LEAK

### One 1/16" hole in a hose leaks at 100 PSIG:

- 4.25 cubic feet per minute (CFM)
- 255 cubic feet per hour
- 2,040 cubic feet in an 8-hour day
- 6,120 cubic feet per 24 hours

### The cost of one leaking air hose:

|                            |   |  |   |                            |
|----------------------------|---|--|---|----------------------------|
| 240                        | X | 6,120  | = | 1,468,800                  |
| working days<br>per year   |   | leakage in cf<br>per 24 hours                                  |   | air lost in cf<br>per year |
| 1,468,800                  | X | \$.00041*  | = | \$602.21*                  |
| air lost in cf<br>per year |   | cost per cf based on typical<br>energy costs per kilowatt-hour |   | total cost<br>per year!    |

\*Costs will vary based on local charges per kilowatt-hour.

## PLUG CONNECTORS

### Compare Airflow SCFM (L/Min)

All information based upon size of I.D. at 90 PSIG (6.2 Bar) in conjunction with mating coupler.



**Common Plug Connector**

- 25 SCFM (708 L/Min)



**Dynabrade Plug Connector**

- 76 SCFM (2152 L/Min)

# MEASUREMENT CONVERSION (US TO INTERNATIONAL)

| Type     | U.S. Unit of Measure | Conversion Formula         | International Unit of Measure    |
|----------|----------------------|----------------------------|----------------------------------|
| Distance | Inch                 | x 25.4                     | Millimeter (mm)                  |
| Mass     | Pound                | x .454                     | Kilogram (kg)                    |
| Pressure | PSIG                 | ÷ 14.5 (.0689) Alternative | Bar                              |
| Speed    | SFPM                 | x .3048                    | Surface Meters Per Minute (SMPM) |
| Flow     | SCFM                 | x 28.32                    | Liters Per Minute (L/Min)        |
| Power    | hp                   | x 745.7                    | Watts (W)                        |

## REFERENCE CONTACT INFORMATION

### American National Standards Institute – ANSI

25 West 43<sup>rd</sup> Street  
Forth Floor  
New York, NY 10036  
Tel: 1 (212) 642-4900  
Email: [www.ansi.org](http://www.ansi.org)

### Government Printing Office – GPO

Code of Federal Regulations (CFR)  
Tel: 1-866-512-1800  
Email: [www.OSHA.com](http://www.OSHA.com)

### European Committee for Standardization – CEN

CEN-CENELEC Management Centre  
Avenue Marnix 17  
4<sup>th</sup> Floor  
B-1000 Brussels  
Tel: + 32 2 550 08 11  
Email: [www.cen.eu](http://www.cen.eu)

### Compressed Air & Gas Institute – CAGI

1300 Sumner Ave.  
Cleveland, Ohio 44115  
Tel: 1-216-241-7333  
Email: [www.cagi.org](http://www.cagi.org)

### Sullair Corporation (Air Compressor Technology)

3700 E. Michigan Blvd.  
Michigan City, Indiana 46360  
Email: [www.sullair.com](http://www.sullair.com)

## DYNABRADE CONTACT INFORMATION

### DYNABRADE, INC.

8989 Sheridan Drive  
Clarence, New York 14031-1490

### DYNABRADE EUROPE S.à.r.l.

Zone Artisanale  
L-5485 Wormeldange-Haut  
Luxembourg

### DYNABRADE INDIA

#### ABRASIVE POWER TOOLS Pvt Ltd.

EL-54, TTC Industrial Area, M.I.D.C. Mahape, Electronic Zone  
Navi Mumbai - 400705, Maharashtra, India

**Website:** [Dynabrade.com](http://Dynabrade.com)

**Automotive Website:** [Dynabradeauto.com](http://Dynabradeauto.com)

**US Customer Service Email:** [customer.service@dynabrade.com](mailto:customer.service@dynabrade.com)

**European Customer Service Email:** [customer.service@dynabrade.lu](mailto:customer.service@dynabrade.lu)

**Automotive Customer Service Email:** [autoaft@dynabrade.com](mailto:autoaft@dynabrade.com)

**Call: US Toll Free:** 1-800-828-7333

**Canada Toll Free:** 1-800-344-1488

**India:** +91 22 2763 2226

**US & Int:** (716) 631-0100

**Eur.:** +352 768 494 1

**Fax: US:** (716) 631-2073

**Int.:** (716) 631-2524

**India:** +91 22 2763 2228

**Eur.:** +352 768 495

