

INSTALLATION INSTRUCTIONS

WARNINGS AND CAUTIONS:

- **DISCONNECT POWER AT CIRCUIT BREAKER OR FUSE WHEN SERVICING, INSTALLING OR REMOVING FIXTURE.**
- **DO NOT** control a load in excess of the specified ratings. Damage to the unit, fire, electric shock, personal injury or death can occur. Check your load ratings to determine suitability for your application.
- If you are unsure about any part of these instructions, consult an electrician.
- To be installed and/or used in accordance with electrical codes and regulations.

WARNINGS AND CAUTIONS:

- Do not install this unit to control a receptacle.
- The OSSMT Vacancy Sensor is intended to replace a standard single-pole Decora wall switch.
- Do not touch the surface of the lens. Clean outer surface with a damp cloth only.
- Use this device **WITH COPPER OR COPPER CLAD WIRE ONLY.**

TOOLS NEEDED TO INSTALL YOUR SENSOR

- Slotted/Phillips Screwdriver
- Pliers
- Small Slotted Screwdriver
- Electrical Tape
- Cutters

FEATURES

- CEC Title 20 and 24 Compliant.
- Manual ON/Auto OFF.
- Leviton's Decora® design.
- Sensor can be ganged together with other units in a multiple-switch wall plate.
- Self-Adaptive Technology adjusts to occupancy patterns of use in auto adapt mode.
- The Adapting Time-out walk-through feature prevents lights from remaining ON for an extended period after only a momentary occupancy.
- Switches a single load circuit.
- Adjustable horizontal blinders for both left and right PIR masking.
- True Zero-Cross relay provides maximum contact life and compatibility with electronic ballasts.
- Dual detection technology, both Passive Infrared and Ultrasonic. OSSMT-GT can be configured as Ultrasonic Only by disabling Passive Infrared.
- Devices can operate in Multi-Tech or Passive Infrared Only mode.
- Time Delay: 30 seconds to 30 minutes.
- LED (Red/Green): Visible status indicators for determining sensing technology operation.
- Vacancy Confirmation: a 30 second grace period is enabled in case of False OFF.

DESCRIPTION

Leviton's Designer Multi-Technology Wall Switch Vacancy Sensor, Cat. No. OSSMT-GT/OSSMT-TM, is designed to detect motion using the Passive Infrared (PIR) and Ultrasonic sensor from sources (such as a person entering a room) within its field-of-view (monitored space). The Vacancy Sensor senses motion within its maximum coverage area of 2400 sq. ft (223 m²). The ultrasonic (US) sensors work with the PIR to keep the lights ON when occupied. The controlled lights will remain ON until no motion is detected and the scheduled time-delay has expired, at which point the lights will be turned OFF. In adapting time-out mode the sensor adapts its time delay settings to the occupancy patterns of a room.

The OSSMT is designed to control a single lighting control circuit and provide the energy savings of an vacancy sensor. The OSSMT-GT does not contain a neutral conductor. It is intended for use in retrofit applications where a neutral is not available in the wall box.

The OSSMT is a single relay device, which operates in Manual ON/ Auto OFF ONLY.

Cat.No. OSSMT-TM is UL and cUL listed. Cat. No. OSSMT-GT is ETL listed and cETL listed.

The PIR technology of the Vacancy Sensor uses a small semiconductor heat detector that resides behind a multi-zone optical lens. This Fresnel lens establishes dozens of zones of detection. The Sensor is sensitive to the heat emitted by the human body. In order to initially trigger the Sensor, the source of heat must move from one zone of detection to another. The device is most effective in sensing motion across its field-of-view and it is less effective sensing motion towards or away from its field-of-view. Keep this in mind when selecting the installation location (refer to Field-of-View diagrams).

The Ultrasonic technology of the Vacancy Sensor uses a non-audible, high frequency (40kHz) sound to sense Doppler shifts caused by motion in the space. The US is more sensitive to small motion and does not rely on line of sight for detection. If both technologies have not detected any motion for the set timeout period, the relay and its corresponding load will be turned OFF.

Note that PIR technology responds to rapid changes in temperature, so care should be taken not to mount the device near a climate control source (i.e. radiators, air exchanges, and air conditioners). Hot or cold drafts will look like body motion to the device and will trigger it if the unit is mounted too close. **It is recommended to mount the Vacancy Sensor at least 6 feet away from a climate control source.**

In addition, it is also recommended NOT to mount the Vacancy Sensor directly under a large light source. Large wattage bulbs (greater than 100W incandescent) give off a lot of heat and switching the bulb causes a temperature change that can be detected by the device. Mount the Vacancy Sensor at least 6 ft. away from large bulbs. If it is necessary to mount the device closer, lower the wattage of the bulb directly overhead.

INSTALLING YOUR SENSOR

NOTE: Use check boxes when Steps are completed.

Step 1 WARNING: TO AVOID FIRE, SHOCK, OR DEATH; TURN OFF POWER at circuit breaker or fuse and test that power is off before wiring!

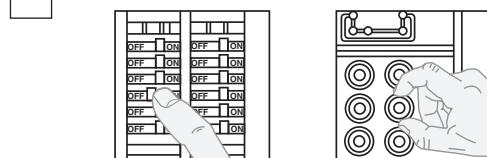

Step 2 Identifying your wiring application (most common):

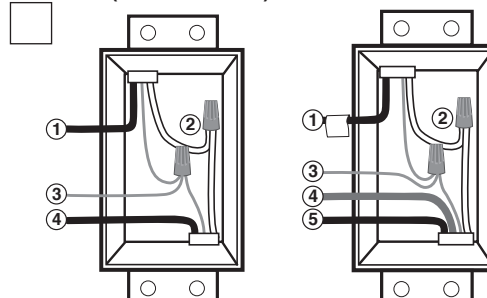

- Single-Pole**
1. Line (Hot)
 2. Neutral
- NOTE: for OSSMT-TM only.
3. Ground
 4. Load
- 3-Way**
1. Line or Load (See important* instruction)
 2. Neutral
- NOTE: for OSSMT-TM only
3. Ground
 4. First Traveler – note color
 5. Second Traveler – note color

Note: These products are not true 3-way devices. **IMPORTANT:** For Multi-location applications, note that one of the screw terminals from the old switch being removed will usually be a different color (Black) or labeled Common. Tag that wire with electrical tape and identify as the common (Line or Load) in both switch wall boxes.

Step 3 Preparing and connecting wires:

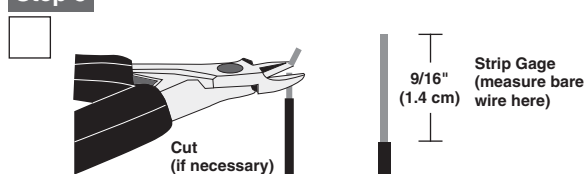

- Pull off pre-cut insulation from sensor leads.
- Make sure that the ends of the wires from the wall box are **straight (cut if necessary).**
- Remove insulation from each wire in the wall box as shown.

Step 4 Installing your Sensor – Single-Pole Application:

NOTE: Cat. No. OSSMT-TM requires a neutral wire. If there is no neutral wire this device will not work.

NOTE: The Cat. No. OSSMT-GT requires a ground wire to operate properly. If there is no ground wire, ensure electrical box is grounded and attach ground wire to box with a screw. If the ground wire is floating this device will not work.

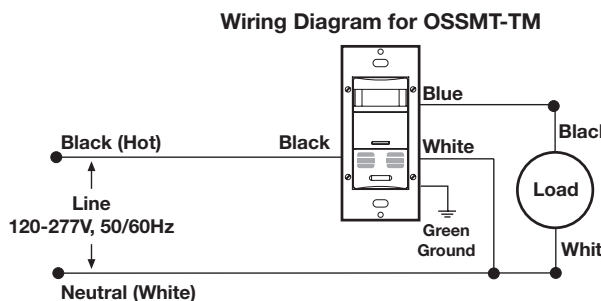
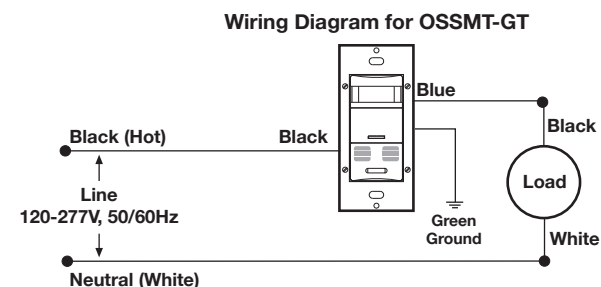

WIRING SENSOR: Connect wires per WIRING DIAGRAM as follows: Screw wire connector on clockwise making sure there are no bare conductors below the wire connectors. Secure each connector with electrical tape.

- Green or bare copper wire in wall box to Green lead.
- Line Hot wall box wire to Black lead.
- Load wall box wire to Blue lead.

NOTE: Allow 1 minute for warm-up after connecting and energizing.

Step 5 Installing your Sensor – Multi-location Wiring Application:

NOTE: The Cat. No. OSSMT-GT requires a ground wire to operate properly. If there is no ground wire, ensure electrical box is grounded and attach ground wire to box with a screw. If the ground wire is floating this device will not work.

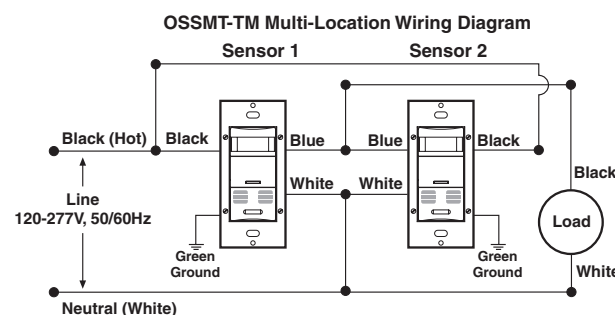
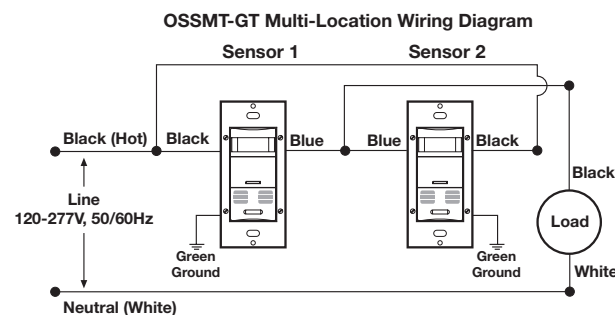

NOTE: Sensor 1 must be installed in a wall box that has both a LINE Hot and a Ground connection. Sensor 2 must be installed in a wall box that has both a Load and a Ground connection.

If you are unsure about any part of these instructions, consult an electrician.

NOTE: Either sensor can turn the lights ON. Both sensors must time out to OFF for the lights to go OFF.

WIRING SENSOR 1: Connect wires per WIRING DIAGRAM as follows:

- Green or bare copper wire in wall box to Sensor 1 Green lead.
- Line Hot (common) wall box wire identified (tagged) when removing old switch and First traveler from Sensor 2 to Sensor 1 Black lead.
- Second Traveler wall box wire from Sensor 2 to Sensor 1 Blue lead.
- For OSSMT-TM tie Neutral wires together.

WIRING SENSOR 2: Connect wires per WIRING DIAGRAM as follows:

- Green or bare copper wire in wall box to Sensor 2 Green lead.
- Load wall box wire identified (tagged) when removing old switch and Second Traveler from Sensor 1 to Sensor 2 Blue lead.
- First Traveler Line Hot from Sensor 1 to Sensor 2 Black lead.

NOTE: Allow 1 minute for warm-up after connecting and energizing.

Step 6 Testing your Sensor prior to completely mounting in wall box:

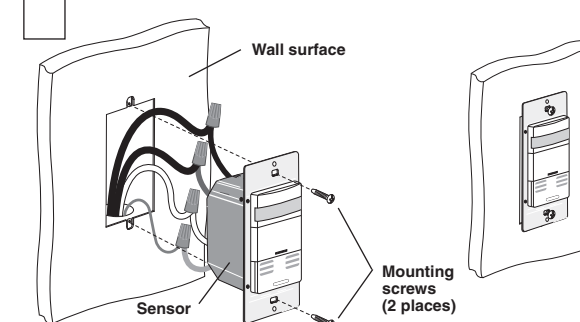

NOTE: Dress wires with a bend as shown in diagram to relieve stress when mounting device.

- Position all wires to provide room in outlet wall box for device.
- Partially secure device using long mounting screws provided.
- Restore power at circuit breaker or fuse.

NOTE: Allow 1 minute for warm-up after energizing.

NOTE: All models of the OSSMT are factory preset to work without any adjustments. If necessary, adjust the Blinders and PIR Range Control to stop any unwanted detection of motion (refer to FEATURES section).

For additional Time Control Settings (refer to the SETTINGS section).

NOTE: To avoid PERMANENT DAMAGE to the unit, be careful NOT TO OVERTURN the control knobs or levers when setting the Sensor. The controls can be accessed by removing the wallplate (if applicable) and control panel cover (refer to Control Panel Diagram). Use a small straight blade screwdriver to adjust knobs and blinder levers.

NOTE: DO NOT press in on blinder levers or use excessive force (refer to Control Panel Diagram).

- Attach the Control Panel cover when the desired settings are complete. If lights do not turn ON, refer to the TROUBLESHOOTING section.

FEATURES

NOTE: To access control settings, remove the control panel cover. If necessary, remove the warning label that covers the adjustment dials (refer to Control Panel Diagram).

Factory Settings: The sensor is shipped from the factory to work in almost all situations, without any added adjustments. The factory settings are: Blinders open, 10 minutes fixed Time-Out, Medium passive infrared (PIR) range, and Medium Ultrasonic range. The PIR and ultrasonic technologies are both active.

Blinders: The blinders are two independent shutters that can narrow the field-of-view from a maximum of 180° down to 60° of arc. The blinders are operated by moving the blinder levers towards or away from the center of the Sensor. The blinder levers can be found above the control dials in the control panel (refer to Control Panel Diagram).

Time-Outs: The Sensor has three types of Time-Outs: Fixed, Adapting, and Walkthrough.

- **Fixed Time-Out:** The value of this Time-Out is user selected through the use of the Time Control Setting (refer to Control Panel Diagram and Time-Out Settings).
- **Adapting Time-Out:** When activated, the value of this Time-Out (30 minutes) is changed by the Sensor based on room occupancy and lighting conditions.
- **Walk-through Time-Out:** The value of this Time-Out is preset to 2.5 minutes and only exists in the Adapting Time-Out mode.

Fixed Time Delay: The fixed Time-Out value is selected by rotating the Time Control dial. There are four (4) values from which to choose. Each mark around the dial corresponds to a different value as indicated below (refer to Control Panel Diagram).

NOTE: All time durations are approximate within ± 10 seconds.

Adapting Time Delay: The Sensor has built in adapting intelligence that changes the Adapting Time-Out duration in response to the occupancy conditions of the room it is installed in. If the Sensor detects "large," infrequent motion it will INCREASE the Adapting Time-Out duration. If the Sensor detects "large," frequent motion (as in several persons in a room during a meeting), it will DECREASE the time-out duration only if it was NEVER increased (this is because the built in intelligence will always proceed in the direction of "increasing" adapting Time-Out once it has increased it for any of the occupancy conditions sensed). The Adapting Time-Out duration will range from 10 to 30 minutes in time plus the Walk-Through Time Delay.

Walk-Through Time Delay: The walk-through feature which is only active in the Adapting Time-Out mode, is useful when a room is momentarily occupied. With this feature, the Sensor will turn the lights OFF shortly after the person leaves the room. The walk-through feature works in the following manner: The lights must be manually turned ON. If the person leaves the room before the walk-through time-out of 2.5 minutes, the Sensor will turn the lights OFF after 2.5 minutes. If the person stays in the room for longer than 2.5 minutes, the Sensor will instead use the stored Adapting Time-Out Delay setting.

If the Sensor detects motion within 30 seconds after the lights turn OFF, it will turn the lights ON and increase the time-out value by 1.5 times the existing value.

The Adapting Time-Out may be reset to the base value of 30 minutes by rotating the Time Control to a new time selection value and then back to the Adapting Time-Out value (refer to Control Panel Diagram).

Manual ON Mode: This Vacancy Sensor only operates in the Manual ON mode.

Vacancy Confirmation: The OSSMT Vacancy Sensor has a 30 second grace period when the lights turn OFF. If motion is detected during this 30 second time frame the lights will automatically turn back ON. This grace period exist in case a false-OFF occurs where the lights go off in a room while the room is still occupied.

PIR RANGE: To decrease PIR detection range and sensitivity, rotate the knob CCW (refer to Control Panel Diagram). The detection range can be adjusted from 100% (40 ft) down to 30% (10 - 20 ft).

ULTRASONIC (US) SENSITIVITY AND PIR DISABLE: US sensitivity can be adjusted to HIGH-MEDIUM or LOW by holding the ON button for 15 seconds. The LED will flash to represent the Ultrasonic sensitivity and PIR status. Tapping the ON button during the desired LED flash indication will set the Ultrasonic sensitivity and PIR status. Use the following chart (NOTE: Green flashes on OSSMT-GT models only):

US Sensitivity and PIR Disable	
3 amber flashes	High ultrasonic sensitivity, PIR enabled
2 amber flashes	Medium ultrasonic sensitivity, PIR enabled
1 amber flash	Low ultrasonic sensitivity, PIR enabled
3 green flashes	High ultrasonic sensitivity, PIR disabled
2 green flashes	Medium ultrasonic sensitivity, PIR disabled
1 green flash	Low ultrasonic sensitivity, PIR disabled

NOTE: The program times out in 30 seconds from the last button press. The factory setting for the US sensitivity is Medium with PIR and Ultrasonic technologies enabled.

Disable/Enable Ultrasonic Technology:

- 1 Hold the button down for 6-7 seconds.
- 2 Release button. Red Led blinking = PIR only.
Green LED blinking = US active.

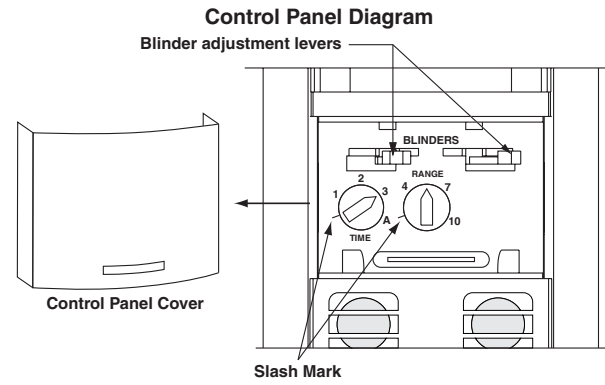

SETTINGS

NOTE: To avoid PERMANENT DAMAGE to the unit, be careful NOT TO OVERTURN or use excessive force when setting the control knobs or levers of Cat No. OSSMT. Use a small straight blade screwdriver to adjust the knobs and your finger to adjust the blinder levers.

1. Remove Decora® wallplate and Control Panel Cover from Sensor.
2. Rotate the Time dial to select the desired fixed Time-Out value.
3. If the Sensor is installed within 6 feet of an air duct, rotate the Range Control 1/4 turn counter-clock-wise (CCW).
4. **Time-Out Settings:**
 - A. Adjust the Time dial. The Sensor Amber LED will flash twice each time the Time dial is pointed at a new Time-Out value. The Time-Out values for non-adapting mode are:
 - NOTE: To return to adapting mode, rotate the Time dial to full CW position (A setting). Be sure the Time dial is rotated until an Amber LED flash is issued to be sure a new setting was selected.

Face Marking	Value of Time
(/) Slash Mark	30 second fixed time-out for performing a walk test
1	10 minutes fixed time-out
2	20 minutes fixed time-out
3	30 minutes fixed time-out
A	Auto Adapting

5. If desired, adjust the blinders to block any unwanted motion.
6. Replace the Control Panel Cover and Decora® wallplate.

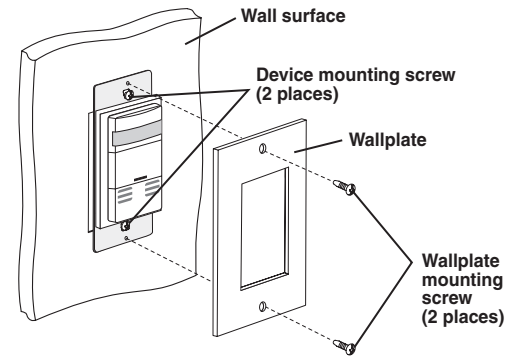

- Secure device by firmly tightening mounting screws.
- Install Decora® wallplate (sold separately).

NOTES

PUSH BUTTON(S)

Manual ON/Auto OFF: In Manual ON/Auto OFF mode the lights can only be turned ON manually. In the absence of motion, after the time out expires, the lights will turn OFF.

NOTES:

- The Motion Indicator LED will blink every second while motion is detected. A red blink represents PIR detection, a green blink represents Ultrasonic detection.
- The OSSMT Vacancy Sensor has a 30 second grace period when the lights turn OFF. If motion is detected during this 30 second time frame the lights will automatically turn back ON. After this time the device will go back to a Manual ON ONLY device.

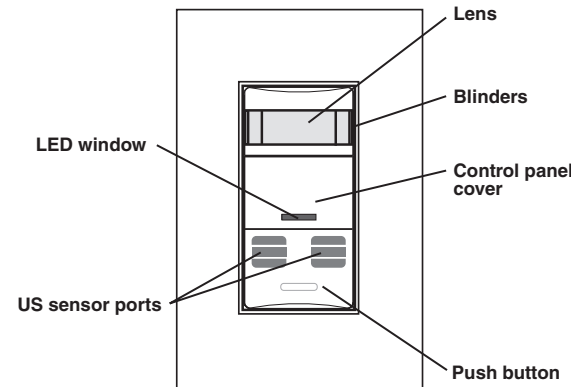

Field - of - View (Horizontal)

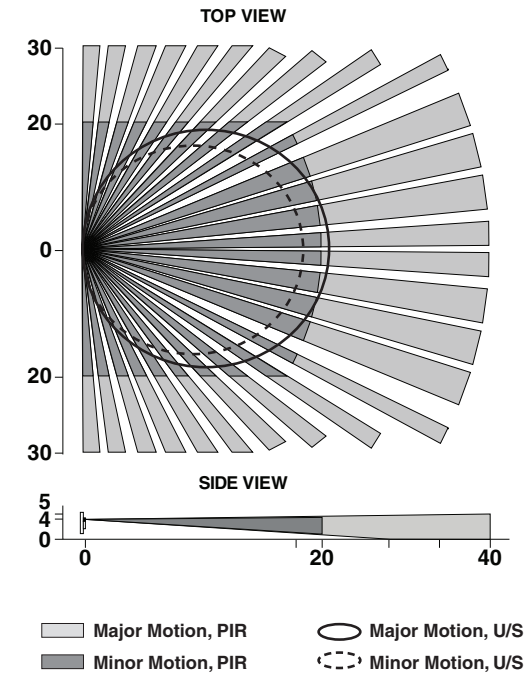

Minor Motion = Dual Technology coverage. This also represents the maximum ultrasonic range coverage.

TROUBLESHOOTING

1. If there is no response from the unit and the LED never blinks, then uninstall device and verify wiring (Step 4).
2. If the lights are nuisance tripping ON from hallway or other unwanted locations:
 - A. Try lowering the PIR Range Control. Rotate the knob counterclockwise and repeat as needed.
3. If the lights constantly stay ON, even when the room is unoccupied:
 - A. Try lowering the Ultrasonic Sensitivity.
 - B. Be sure to use the Blinders to block any unwanted hallway traffic.
 - C. Check for reflected radiated heat/motion such as incandescent bulbs, mirrors, HVAC, swinging fixtures, moving mechanical parts, flowing hot water within view, overhead doors opening closing, etc.
 - D. Check for adjacent HVAC and/or heater ducts. If your OSSMT has a flashing amber LED, the zero-cross failure over-ride has occurred, but the sensor will still operate until you are able to reach technical assistance.
4. If the sensor is turning lights OFF (False OFF):
 - A. Check time delay and extend to 20 or 30 minutes.
 - B. Check range sensitivity of PIR and U/S and increase.

PRODUCT INFORMATION

- For technical assistance contact us at 1-800-824-3005
- Visit our website at www.leviton.com

FCC COMPLIANCE STATEMENT

This device complies with Part 15 of the FCC Rules. Operation is subject to following two conditions: (1) this device may not cause harmful interference, and (2) this device must accept any interference received, including interference that may cause undesired operation of the device.

This equipment has been tested and found to comply with the limits for a Class B Digital Device, pursuant to Part 15 of the FCC Rules. These limits are designed to provide reasonable protection against harmful interference in a residential installation. This equipment generates, uses, and can radiate radio frequency energy and, if not installed and used in accordance with the instructions, may cause harmful interference to radio communications. However, there is no guarantee that interference will not occur in a particular installation. If this equipment does cause harmful interference to radio or television reception, which can be determined by turning the equipment OFF and ON, the user is encouraged to try to correct the interference by one or more of the following measures:

- Reorient or relocate the receiving Antenna.
- Increase the separation between the equipment and the receiver.
- Connect the equipment into an outlet on a circuit different from that to which the receiver is connected.
- Consult the dealer or an experienced radio/tv technician for help.

FCC CAUTION

Any changes or modifications not expressly approved by Leviton Manufacturing Co., Inc., could void the user's authority to operate the equipment.

LIMITED 5 YEAR WARRANTY AND EXCLUSIONS

Leviton warrants to the original consumer purchaser and not for the benefit of anyone else that this product at the time of its sale by Leviton is free of defects in materials and workmanship under normal and proper use for five years from the purchase date. Leviton's only obligation is to correct such defects by repair or replacement, at its option, if within such five year period the product is returned prepaid, with proof of purchase date, and a description of the problem to Leviton Manufacturing Co., Inc., Att: Quality Assurance Department, 201 North Service Road, Melville, New York 11747. This warranty excludes and there is disclaimed liability for labor for removal of this product or reinstallation. This warranty is void if this product is installed improperly or in an improper environment, overloaded, misused, opened, abused, or altered in any manner, or is not used under normal operating conditions or not in accordance with any labels or instructions. There are no other or implied warranties of any kind, including merchantability and fitness for a particular purpose, but if any implied warranty is required by the applicable jurisdiction, the duration of any such implied warranty, including merchantability and fitness for a particular purpose, is limited to five years. Leviton is not liable for incidental, indirect, special, or consequential damages, including without limitation, damage to, or loss of use of, any equipment, lost sales or profits or delay or failure to perform this warranty obligation. The remedies provided herein are the exclusive remedies under this warranty, whether based on contract, tort or otherwise.