

**CHAMPION**



**Carbide Tipped Hole Cutters**

# CT3

CARBIDE TIPPED HOLE CUTTERS

The solution for drilling holes in sheet metal up to 1/8" thick

- Deliver "more holes per charge" in battery-powered drills
- Cut thin materials, including stainless steel, quickly and smoothly
- 1/4" Hex Shank for use in QCD (quick-change driver)
- Thin wall construction and three carbide tips for fast drilling and reduced drag

### 1 Special tungsten carbide teeth

- Excellent wear and heat resistance
- Cuts stainless steel and tough alloys

### 2 Ejector spring

- Ejects the slug, saving time

### 3 1/4" Hex Shank

- No assembly required
- Stable accurate drilling

### 4 Safety collar stop

- Prevents over penetration for safer, faster operation

### Applications

- Junction / Switch Boxes
- Metal Studs
- Electrical Appliances
- Auto Body Repair

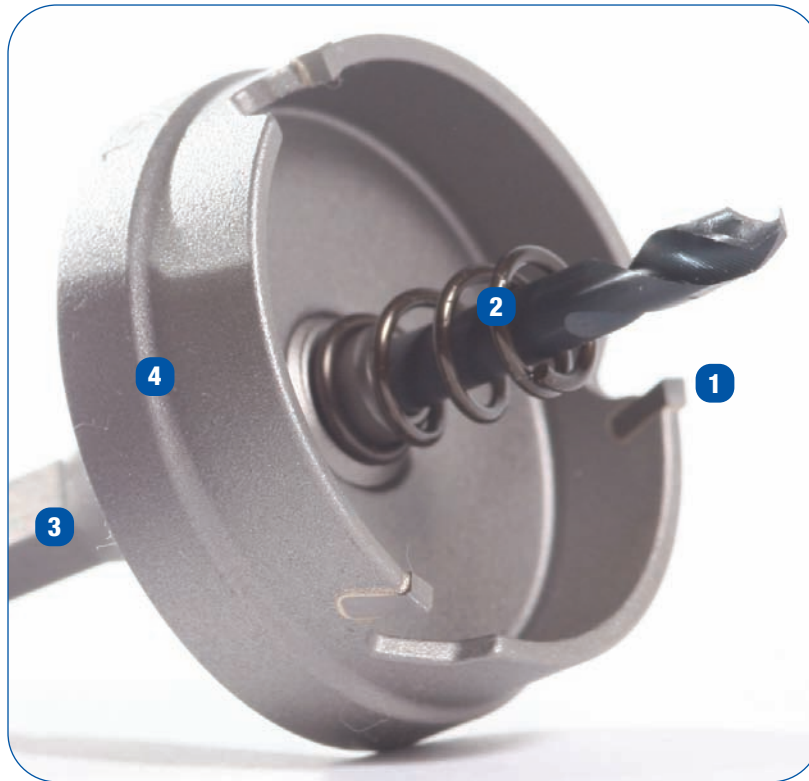

### EDP No. / Size

- CT3-5/8
- CT3-11/16
- CT3-3/4
- CT3-13/16
- CT3-7/8
- CT3-15/16
- CT3-1
- CT3-1-1/16
- CT3-1-1/8
- CT3-1-3/16
- CT3-1-1/4
- CT3-1-5/16
- CT3-1-3/8

### SPARE PARTS

- CT3-PILOT
- CT3-SCREW
- CT3-SPRING



### Carbide Tipped Hole Cutters Speed Recommendation

Size	Steel (rpm)	Stainless Steel (rpm)
9/16 to 13/16	700-100	300-700
7/8 to 1-3/16	500-800	200-450
1-1/4 to 1-9/16	300-600	175-315
1-5/8 to 2	200-500	120-225
2-1/16 to 2-3/8	200-400	95-195
2-7/16 to 3	150-300	80-150
3-1/16 to 6	100-200	60-120

Up to **150 holes** with each cutter in **Stainless Steel**

# CT5

CARBIDE TIPPED HOLE CUTTERS

The cutting tool for ferrous and non-ferrous materials up to 3/16" thick

- **NEW DESIGN FOR LONGER LIFE AND FASTER CUTTING**
- **Perfect portable tool for the professional electrician, plumber, mechanic and contractor**
- **Extremely productive tool that is a cost effective alternative to bi-metal holesaws**
- **For cutting steel plate, iron, aluminum, copper, cast iron, stainless steel, FRP (i.e fiberglass) and plastics**
- **9/16" to 2-5/8" have 3/8" shank, 2-3/4" to 5" have 1/2" shank**

### 1 Special tungsten carbide teeth with NEW carbide tip pocket

- Tip pocket for quicker chip extraction
- Excellent wear and heat resistance
- Cuts stainless steel and tough alloys

### 2 Strong, heat resistant ejector spring

- Ejects the slug faster, saving time

### 3 NEW Stepped pilot drill

- Reduces tip impact

### 4 One piece construction

- No assembly required
- Stable accurate drilling

### 5 Safety collar stop

- Prevents over penetration for safer, faster operation

### Applications

- Junction / Switch Boxes
- Metal Studs
- Appliances
- Auto Body Repair
- Truck Body Repair

### Smooth Cutting Geometry

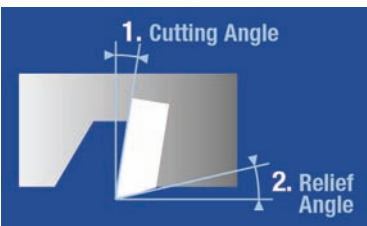

Ultra-hard tungsten carbide teeth penetrate stainless steel. Relief angle provides smooth cutting and reduces friction.

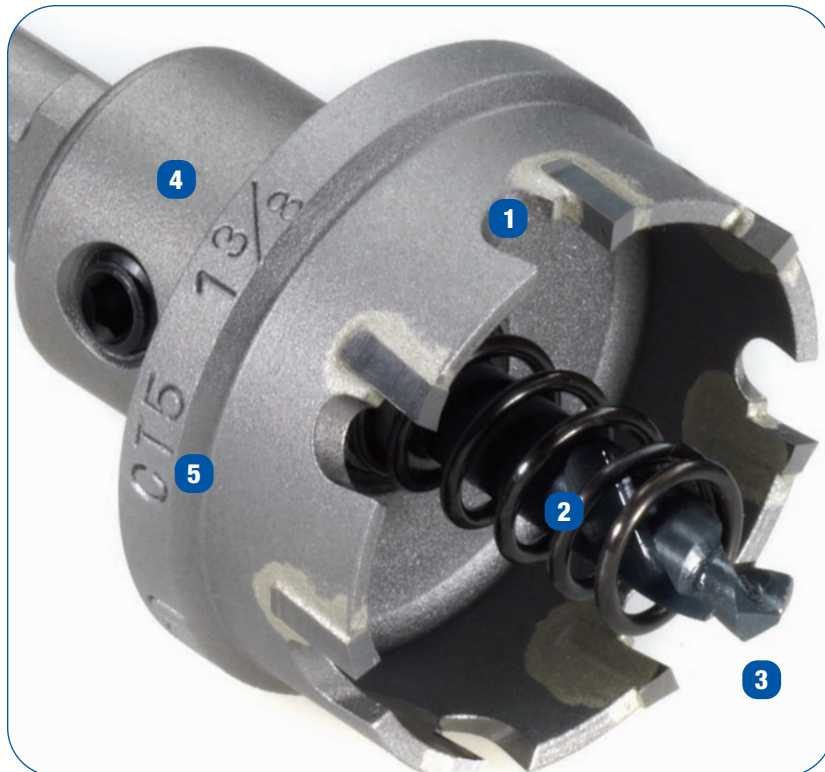

### PERFORMANCE COMPARISON NEW CT5 to PREVIOUS CT5 (2")

Material: SUS304 Stainless Steel  
Material thickness: 1/8" - Speed: 800 rpm

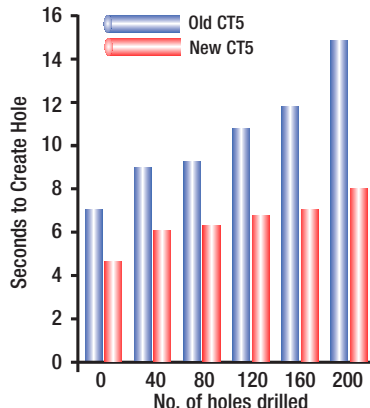

**60%**  
Faster Cutting  
(up to 100 holes)  
**20%**  
More Holes



### EDP No. / Size

- CT5-9/16
- CT5-5/8
- CT5-11/16
- CT5-3/4
- CT5-13/16
- CT5-7/8
- CT5-15/16
- CT5-1
- CT5-1-1/16
- CT5-1-1/8
- CT5-1-3/16
- CT5-1-7/32
- CT5-1-1/4
- CT5-1-5/16
- CT5-1-3/8
- CT5-1-7/16
- CT5-1-1/2
- CT5-1-9/16
- CT5-1-5/8
- CT5-1-11/16
- CT5-1-3/4
- CT5-1-13/16
- CT5-1-7/8
- CT5-1-15/16
- CT5-2
- CT5-2-1/16
- CT5-2-1/8
- CT5-2-3/16
- CT5-2-1/4
- CT5-2-5/16
- CT5-2-3/8
- CT5-2-7/16
- CT5-2-1/2
- CT5-2-9/16
- CT5-2-5/8
- CT5-2-11/16
- CT5-2-3/4
- CT5-2-13/16
- CT5-2-7/8
- CT5-2-15/16
- CT5-3
- CT5-3-1/8
- CT5-3-1/4
- CT5-3-3/8
- CT5-3-1/2
- CT5-3-5/8
- CT5-3-3/4
- CT5-3-7/8
- CT5-4
- CT5-4-1/8
- CT5-4-1/4
- CT5-4-3/8
- CT5-4-1/2
- CT5-4-3/4
- CT5-5

### SPARE PARTS

- CT5-PILOT
- CT5-SCREW
- CT5-SPRING
- CT5 PILOT-TCT\*

\* for abrasive materials

# CT7

CARBIDE TIPPED HOLE CUTTERS

The best cutting tool for drilling holes up to 1" thick ferrous and non-ferrous materials

- Perfect portable tool for the professional electrician, plumber, mechanic and contractor
- Productive tool that is a cost effective alternative to bi-metal holesaws
- For cutting steel plate, iron, aluminum, copper, cast iron, stainless steel, FRP (i.e fiberglass) and plastics up to 1" thick
- 9/16" to 3" have 3/8" shank, 3-1/4" to 4-1/2" have 1/2" shank

### 1 Special tungsten carbide teeth

- Excellent wear and heat resistance
- Cuts stainless steel and tough alloys

### 2 Ejector spring

- Ejects the slug

### 3 One piece construction

- No assembly required
- Stable accurate drilling

### 4 Safety collar stop

- Prevents over penetration for safer, faster operation

### Applications

- Junction / Switch Boxes
- Metal Studs
- Appliances
- Auto Body Repair
- Truck / Trailer Frames
- Ductile Pipe

### Triple Edge Cutting System

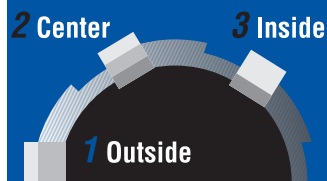

CT7 hole cutters feature triple-cutting geometry for smooth, fast cutting. The unique geometry delivers rapid chip removal and better control.

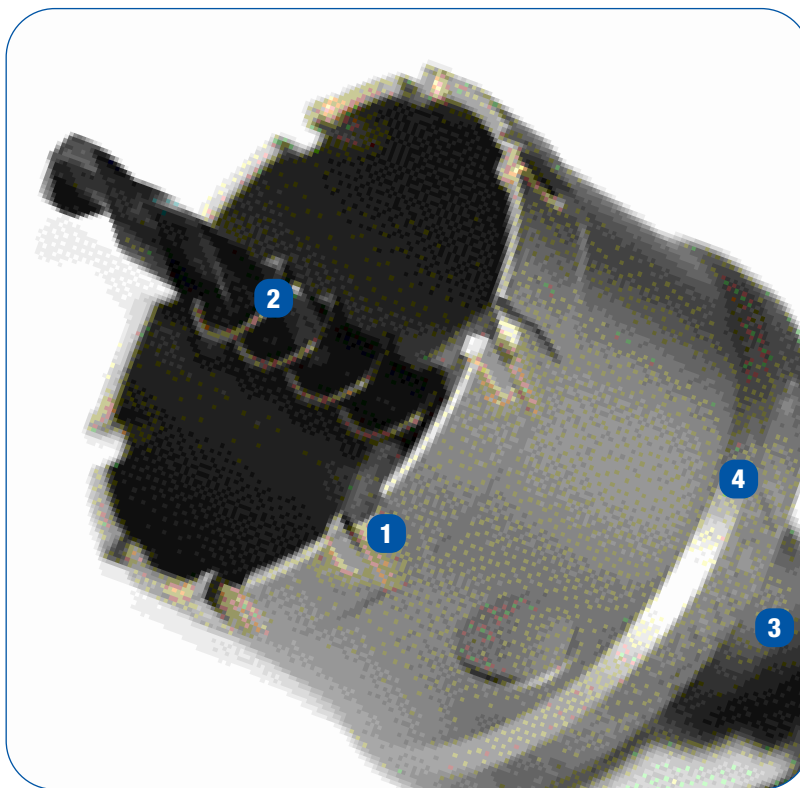

### EDP No. / Size

- CT7-9/16
- CT7-5/8
- CT7-11/16
- CT7-3/4
- CT7-13/16
- CT7-7/8
- CT7-15/16
- CT7-1
- CT7-1-1/16
- CT7-1-1/8
- CT7-1-3/16
- CT7-1-1/4
- CT7-1-5/16
- CT7-1-3/8
- CT7-1-7/16
- CT7-1-1/2
- CT7-1-9/16
- CT7-1-5/8
- CT7-1-11/16
- CT7-1-3/4
- CT7-1-13/16
- CT7-1-7/8
- CT7-1-15/16
- CT7-2
- CT7-2-1/8
- CT7-2-1/4
- CT7-2-3/8
- CT7-2-1/2
- CT7-2-9/16
- CT7-2-5/8
- CT7-2-3/4
- CT7-2-7/8
- CT7-3
- CT7-3-1/4
- CT7-3-1/2
- CT7-3-5/8
- CT7-3-3/4
- CT7-4
- CT7-4-1/8
- CT7-4-1/4
- CT7-4-1/2

### SPARE PARTS

- CT7-PILOT
  - CT7-SCREW
  - CT7-SPRING
  - CT7 PILOT-TCT\*
- \* for abrasive materials

# CT9

CARBIDE TIPPED HOLE CUTTERS

The choice for drilling lockset and deadbolt holes in steel doors

- 2" depth for drilling thick materials
- 3/8" Shanks
- 2-1/8" designed for door knob, 1-1/2" designed for deadbolt

**EDP No. / Size**

CT9-1-1/2

CT9-2-1/8

**SPARE PARTS**

CT9-PILOT

CT9-SCREW

**1 Special tungsten carbide teeth**

- Excellent wear and heat resistance
- Cuts stainless steel and tough alloys

**2 One piece construction**

- No Assembly Required
- Stable accurate drilling



**3 Extra length tool body**

- For extra length of cutting



**Triple Edge Cutting System**

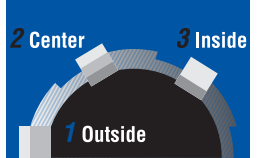

CT9 hole cutters feature triple-cutting geometry for smooth, fast cutting. The unique geometry delivers rapid chip removal and better control.

## Accessories

### CT-EXT Hole Cutter Extensions List No. CT-EXT

- Extend CT5, CT7 & CT9 hole cutters by 4"
- Precision machined tool steel
- Will extend the reach of all 3/8" and 1/2" shank tools



**EDP No. / Size**

**Description**

CT-EXT-3/8

5" x 3/8" shank extension for 3/8" shank CT5, CT7 & CT9

CT-EXT-1/2

5" x 1/2" shank extension for 1/2" shank CT5, CT7 & CT9

### QCD Quick-Change Driver List No. QCD

- Dual 1/4" and 3/8" drill and drive chuck
- 3/8" tools lock into position 1
- 1/4" tools lock into position 2
- Industrial quality with minimal runout (wobble)
- Fits all accessory types, all brands
- Fits old and new hex shanks with or without power groove



**EDP No. / Size**

**Description**

QCD

Quick Change Driver for 1/4" and 3/8" hex shank tools

## Merchandisers

CT3, CT5 & CT7 hole cutters are available in attractive, high impact point of sale displays.

**EDP No.**

**Description**

DIS-CT3M

14 Pc Merchandiser  
5/8" thru 1-3/8"

DIS-CT5M

16 Pc Merchandiser  
9/16" thru 2"

DIS-CT7M

15 Pc Merchandiser  
5/8" thru 2"



# Professional Sets

## CT3 Hole Cutter Sets



EDP No.	Description
CT3P-SET-1	5/8, 3/4, 7/8, 1, 1-1/8 and QCD in plastic case
CT3-SET-1	5/8, 3/4, 7/8, 1 and QCD in metal case
CT3P-SET-2	7/8 (2ea.), 1-1/8 (2ea.), 1-3/8 and QCD in plastic case
CT3-SET-2	7/8 (2ea.), 1-1/8 (2ea.), 1-3/8 and QCD in metal case
ELEC-KIT	MSD-HEX-13, CT3-7/8, CT3-1-1/8, CT3-1-3/8 and QCD in metal case

## CT7 Plumbers Sets



EDP No.	Description
CT7P-PLUMBER-1	6 Piece Plumber Set: 3/4, 7/8, 1-1/8, 1-1/2, 1-3/4, 2-1/4 in plastic case
CT7P-PLUMBER-2	12 Piece Plumber Set: 3/4, 7/8, 1-1/8, 1-1/2, 1-3/4, 2-1/4, 2-9/16, 3, 3-1/2, 4, 4-1/4, 4-1/2 in plastic case

## CT5 Hole Cutter Sets



EDP No.	Description
CT5-SET-1	7/8, 1-1/8, 1-3/8, 1-3/4 and 2 in metal case
CT5P-SET-1	5 Piece Electrical Conduit Set: 7/8, 1-1/8, 1-3/8, 1-3/4 and 2 in plastic case
CT5P-CONDUIT-1	7 Piece Electrical Conduit Set: 7/8, 1-1/8, 1-7/32, 1-3/8, 1-3/4, 2, 2-1/2 in plastic case

## CT7 Hole Cutter Sets



EDP No.	Description
CT7-SET-1	5/8, 3/4, 7/8, and 1 in metal case
CT7-SET-2	11/16, 13/16, 15/16 and 1-1/16 in metal case
CT7-SET-3	7/8, 1-1/8, 1-3/8, 1-3/4 and 2 in metal case
CT7P-SET-4	5 Piece General Maintenance Set: 5/8, 3/4, 7/8, 1 and 1-1/8 in plastic case
CT7P-SET-5	5 Piece Bolt Clearance Set: 9/16, 11/16, 13/16, 15/16 and 1-1/16 in plastic case
CT7P-SET-6	5 Piece Electrical Conduit Set: 7/8, 1-1/8, 1-3/8, 1-3/4 and 2 in plastic case

## CT5 Master Electrical Sets



EDP No.	Description
CT5P-ELECTRICAL-1	10 Piece Master Electrical Set: 7/8, 1-1/8, 1-3/8, 1-3/4, 2, 2-1/2, 3, 3-5/8, 4-1/8 and 4-1/2 in plastic case

## CT7/CT9 Lockset Kit



EDP No.	Description
CT9P-DOOR-SET	CT7-7/8, CT7-1, CT9-1-1/2, CT9-2-1/8 in plastic case

## CT7 Master Electrical and Mechanical Sets



EDP No.	Description
CT7P-ELECTRICAL-1	10 Piece Master Electrical Set: 7/8, 1-1/8, 1-3/8, 1-3/4, 2, 2-1/2, 3, 3-5/8, 4-1/8, 4-1/2
CT7P-MECHANICAL-1	12 Piece Master Mechanical Set: 5/8, 3/4, 7/8, 1, 1-1/8, 1-1/4, 1-3/8, 1-1/2, 1-3/4, 2, 2-1/2, 3



P.O. Box 368, Rockville Centre, NY 11571-0368 Tel: 516-536-8200 Fax: 516-536-8186

[www.championcuttingtool.com](http://www.championcuttingtool.com)

© Copyright 2008 Champion Cutting Tool Corp. All Rights Reserved CT-LIT 0908/20M