

Calbrite™

Stainless Steel Conduit Systems

Stainless Steel Single & Double Gang Blank Covers

Features:

- Manufactured in stainless steel to meet any stringent sanitary condition
- Polished with standard "brite" finish to increase corrosion resistance and aesthetic appearance
- Stainless steel screws included
- Made of .030" thick stainless steel
- Vinyl gasket included
- No package qty. required



Certifications and Compliances:

UL Listed
CSA Approved
Dustproof

Applications:

Calbrite's polished, dust-proof stainless steel covers & plates are designed for use in corrosive and harsh environments. Fits all Calbrite stainless steel Device Box configurations. Note: Not suitable for wet locations. Please see Calbrite's In-Use Covers for requirements in weatherproof / damp environments.

Industries Commonly Served:

- Food & Beverage Production & Distribution
- Chemical Plants
- Water & Wastewater Treatment
- Pharmaceuticals & Cosmetics
- Refining & Extraction Sites
- Petrochemical
- Pulp & Paper Mills
- Marine & Coastal Facilities
- Along with other corrosive environments

DIMENSIONS FOR S607BLPLTS:

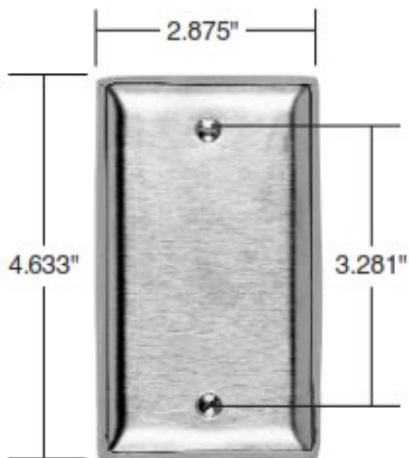

DIMENSIONS FOR S607BLPLTD:

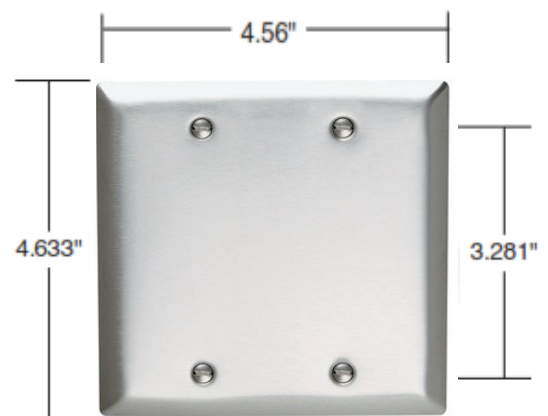

*All dimensions are for informational purposes only *Tolerances +/- 5%*