

## Residential Ultra Low NOx Gas Water Heater



Photo is of  
URG250T6N

### The FVIR Eco-Defender Safety System<sup>®</sup> Models Feature:

- **Bradford White ICON System<sup>®</sup>**—Intelligent gas control with proven millivolt powered technology and built-in piezo igniter. A standard, off-the-shelf thermopile converts heat energy from the pilot flame into electrical energy to operate the gas valve and microprocessor. No need for external electricity.
  - **Enhanced Performance**—Proprietary algorithms provide enhanced First Hour Rating and tighter temperature differential.
  - **Advanced Temperature Control System**—Microprocessor controls burner operation for consistent and accurate water temperature levels up to 160°F (71°C).
  - **Intelligent Diagnostics**—Exclusive multicolor LED light indicates operation status/service required.
- **Defender Combustion Chamber**—Incorporates the Advanced ScreenLok<sup>®</sup> Technology Flame Arrestor and large split-door design to prevent ignition of flammable vapors outside the water heater.
- **Ultra Low NOx Burner with Primary and Secondary Air Distribution Devices**—Ensures proper air to gas ratio for reduction of NOx generated by the combustion process.
- **Digital Thermal Sensor and Resettable Thermal Switch**—Coordinates with self diagnostic control to prevent water heater operation when needed.
- **Maintenance-Free**—No regular cleaning of air inlet openings or flame arrestor is required under normal conditions.
- **Sight Window**—Offers a view into the combustion chamber to observe the operation of the pilot and burner.
- **Factory-Installed Hydrojet<sup>®</sup> Total Performance System**—Sediment reducing device that also increases first hour rating of hot water while minimizing temperature build-up in tank.
- **Vitraglas<sup>®</sup> Lining**—An exclusively engineered enamel formula that provides superior tank protection from the highly corrosive effects of hot water. This formula (Vitraglas<sup>®</sup>) is fused to the steel surface by firing at a temperature of over 1600°F (871°C).
- **Insulation System**—Non-CFC foam covers the sides and top of the tank, reducing heat loss. This results in less energy consumption, improved efficiencies, and jacket rigidity.
- **Pedestal Base**—Rugged and durable base allows easy transport and positioning and corrosion-resistant contact with floor.
- **Water Connections**—3/4" (19mm) NPT factory-installed true dielectric fittings extend water heater life and simplify water line connections.
- **Factory-Installed Heat Traps**—Design incorporates a flexible disk that reduces heat loss in piping and eliminates the potential for noise generation.
- **Protective Magnesium Anode Rod**—Provides added protection against corrosion for long-term, trouble-free service.
- **3x4 "Snap Lock" Draft Diverter**—Allows either 3" (76mm) or 4" (102mm) vent connections with inputs of 40,000 BTU/Hr. or less. Over 40,000 BTU/Hr. has a 4" (102mm) "Snap Lock" Draft Diverter.
- **Flue Baffle**—Maximizes the amount of heat absorbed by the tank and reduces heat loss during standby periods.
- **Steel Tank**—Heavy gauge steel automatically formed, rolled, and welded.
- **T&P Relief Valve.**
- **Low Restrictive Brass Drain Valve**—Durable tamper proof design.
- **Design Certified by CSA International (formerly AGA/CGA).**
- **Complies with the latest Ultra Low NOx requirement (10 ng/J NOx limit).**

### FEATURING:



### 6 or 10-Year Limited Tank Warranties / 6 or 10-Year Limited Warranty on Component Parts.

For more information on warranty, please visit [www.bradfordwhite.com](http://www.bradfordwhite.com)

For products installed in USA, Canada, and Puerto Rico. Some states do not allow limitations on warranties.

See complete copy of the warranty included with the heater.

# Residential Ultra Low NOx Gas Water Heater

## Ultra Low NOx Models

NATURAL GAS

Meet or exceed ASHRAE 90.1b (current standard) C.E.C. Listed  
Recovery efficiency ranging up to 80%

Model Number	Nominal Gal. Capacity		DOE Rated Storage Volume (Gal.)	BTU/Hr. Input	First Hour Rating (Gal.)	Uniform Energy Factor	Recovery at 90°F Rise*		Model Number	Nominal Liter Capacity	DOE Rated Storage Volume (Liters)	kW Input	First Hour Rating (Liters)	Uniform Energy Factor	Recovery at 50°C Rise*	
	U.S. Gal.	Imp. Gal.					U.S. GPH	Imp. GPH							U.S. Gal.	Liters/ Hour
• URG130T6N	30	25	29	27,000	46	0.54	29	24	• URG130T6N	114	110	7.9	174	0.54	110	
• URG230T6N	30	25	29	32,000	60	0.60	34	28	• URG230T6N	114	110	9.4	227	0.60	129	
• URG140T6N	40	33	38	34,000	64	0.59	37	31	• URG140T6N	151	144	10.0	243	0.59	139	
• URG240T6N	40	33	38	40,000	75	0.64	43	36	• URG240T6N	151	144	11.7	284	0.64	163	
• URG240S6N	40	33	38	40,000	69	0.58	43	36	• URG240S6N	151	144	11.7	262	0.58	163	
• URG150T6N	50	42	47	34,000	75	0.63	37	31	• URG150T6N	189	178	10.0	284	0.63	139	
• URG250T6N	50	42	48	40,000	81	0.63	43	36	• URG250T6N	189	182	11.7	307	0.63	163	
• URG250L6N	48	40	47	40,000	77	0.63	43	36	• URG250L6N	182	178	11.7	292	0.63	163	
• URG250S6N	50	42	47	50,000	75	0.63	54	45	• URG250S6N	189	178	14.7	284	0.63	204	

Model Number	A Floor to Flue Conn. in.	B Jacket Dia. in.	C Vent Size in.	D Floor to T&P Conn. in.	E Floor to Gas Conn. in.	F Floor to Top of Heater in.	G Floor to Water Conn. in.	H Depth in.	J C/L of Water Conn. in.	M Water Conn. NPT in.	S Gas Conn. Size in.	Approx. Shipping Weight lbs.
• URG130T6N	59 <sup>15</sup> / <sub>16</sub>	16	3 or 4	56 <sup>3</sup> / <sub>8</sub>	11 <sup>7</sup> / <sub>16</sub>	56 <sup>3</sup> / <sub>8</sub>	56 <sup>15</sup> / <sub>16</sub>	20 <sup>1</sup> / <sub>16</sub>	8	3/4	1/2	112
• URG230T6N	56 <sup>15</sup> / <sub>16</sub>	18	3 or 4	56 <sup>3</sup> / <sub>8</sub>	11 <sup>7</sup> / <sub>16</sub>	56 <sup>3</sup> / <sub>8</sub>	57 <sup>3</sup> / <sub>16</sub>	21 <sup>3</sup> / <sub>16</sub>	8	3/4	1/2	119
• URG140T6N	61 <sup>1</sup> / <sub>2</sub>	18	3 or 4	59 <sup>1</sup> / <sub>2</sub>	11 <sup>7</sup> / <sub>16</sub>	57 <sup>15</sup> / <sub>16</sub>	59 <sup>1</sup> / <sub>2</sub>	22 <sup>3</sup> / <sub>16</sub>	8	3/4	1/2	130
• URG240T6N	60 <sup>3</sup> / <sub>16</sub>	20	3 or 4	56 <sup>3</sup> / <sub>8</sub>	11 <sup>7</sup> / <sub>16</sub>	56 <sup>3</sup> / <sub>4</sub>	57 <sup>3</sup> / <sub>4</sub>	23 <sup>3</sup> / <sub>16</sub>	8	3/4	1/2	137
• URG240S6N	51 <sup>3</sup> / <sub>4</sub>	22	3 or 4	47 <sup>1</sup> / <sub>4</sub>	11 <sup>7</sup> / <sub>16</sub>	48 <sup>3</sup> / <sub>16</sub>	49 <sup>7</sup> / <sub>16</sub>	25 <sup>3</sup> / <sub>16</sub>	8	3/4	1/2	149
• URG150T6N	60 <sup>3</sup> / <sub>16</sub>	20	3 or 4	56 <sup>3</sup> / <sub>8</sub>	11 <sup>7</sup> / <sub>16</sub>	56 <sup>3</sup> / <sub>4</sub>	57 <sup>7</sup> / <sub>8</sub>	24 <sup>3</sup> / <sub>16</sub>	8	3/4	1/2	153
• URG250T6N	60 <sup>3</sup> / <sub>16</sub>	22	3 or 4	57	11 <sup>7</sup> / <sub>16</sub>	56 <sup>11</sup> / <sub>16</sub>	58 <sup>1</sup> / <sub>16</sub>	25 <sup>3</sup> / <sub>8</sub>	8	3/4	1/2	160
• URG250L6N	51 <sup>13</sup> / <sub>16</sub>	24	3 or 4	40 <sup>3</sup> / <sub>8</sub>	11 <sup>7</sup> / <sub>16</sub>	48 <sup>3</sup> / <sub>16</sub>	49 <sup>9</sup> / <sub>16</sub>	27 <sup>3</sup> / <sub>16</sub>	8	3/4	1/2	174
• URG250S6N	60 <sup>3</sup> / <sub>8</sub>	22	4	57	11 <sup>7</sup> / <sub>16</sub>	56 <sup>3</sup> / <sub>4</sub>	57 <sup>15</sup> / <sub>16</sub>	25 <sup>3</sup> / <sub>16</sub>	8	3/4	1/2	169

Model Number	A Floor to Flue Conn. mm.	B Jacket Dia. mm.	C Vent Size mm.	D Floor to T&P Conn. mm.	E Floor to Gas Conn. mm.	F Floor to Top of Heater mm.	G Floor to Water Conn. mm.	H Depth mm.	J C/L of Water Conn. mm.	M Water Conn. NPT mm.	S Gas Conn. Size mm.	Approx. Shipping Weight kg.
• URG130T6N	1522	406	76 or 102	1432	291	1432	1446	510	203	19	13	51
• URG230T6N	1446	457	76 or 102	1432	291	1432	1456	538	203	19	13	54
• URG140T6N	1562	457	76 or 102	1511	291	1472	1511	564	203	19	13	59
• URG240T6N	1532	508	76 or 102	1438	291	1441	1467	589	203	19	13	62
• URG240S6N	1314	559	76 or 102	1200	291	1224	1256	640	203	19	13	68
• URG150T6N	1532	508	76 or 102	1432	291	1441	1470	614	203	19	13	69
• URG250T6N	1532	559	76 or 102	1448	291	1440	1475	645	203	19	13	73
• URG250L6N	1316	610	76 or 102	1032	291	1224	1259	691	203	19	13	79
• URG250S6N	1540	559	102	1448	291	1441	1471	640	203	19	13	77

Available in Natural Gas only.

For 10 year models, change suffix from "6" to "10".

\* Based on manufacturers rated recovery efficiency.

• Models feature optional top T&P location and must be specified when ordering. Note: URG250L6N does not have top T&P option.

Uniform Energy Factor and First Hour Rating is based on the latest AHRI directory listings.

### General:

#### Meets NAECA Requirements.

All gas water heaters are certified at 300 PSI test pressure (2068 kPa) and 150 PSI working pressure (1034 kPa). All water connections are 3/4" NPT (19mm) on 8" (203mm) centers. All gas connections are 1/2" (13mm). All models design-certified by CSA International (formerly AGA/CGA), to meet ANSI standard Z21.10.1 and peak performance rated.

**Dimensions and specifications subject to change without notice in accordance with our policy of continuous product improvement.**

**Suitable for Water (Potable) Heating and Space Heating.** Toxic chemicals, such as those used for boiler treatment, shall NEVER be introduced into this system. This unit may NEVER be connected to any existing heating system or component(s) previously used with a non-potable water heating appliance.

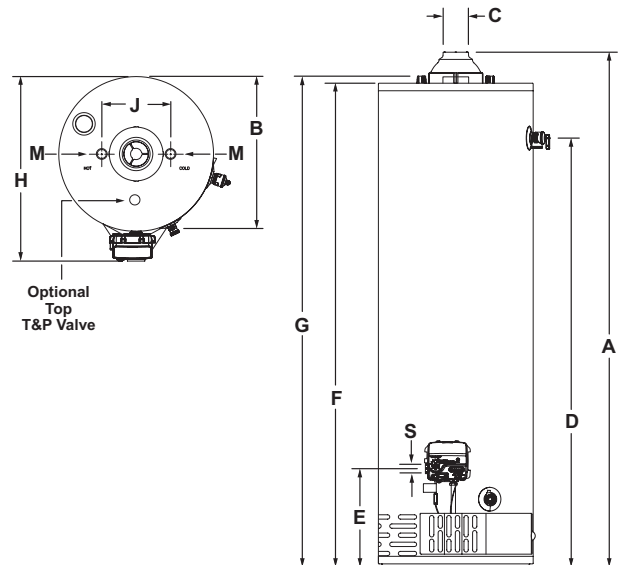

— BRADFORD WHITE IS —



For field service, contact your professional installer or local Bradford White sales representative.

Sales 800-523-2931 ■ Fax 215-641-1612

Technical Support 800-334-3393 ■ Email [techserv@bradfordwhite.com](mailto:techserv@bradfordwhite.com)

Warranty 800-531-2111 ■ Email [warranty@bradfordwhite.com](mailto:warranty@bradfordwhite.com)

International: Telephone 1-215-641-9400 ■ Email [international@bradfordwhite.com](mailto:international@bradfordwhite.com) / [www.bradfordwhite.com](http://www.bradfordwhite.com)

**Built to be the Best™**