

FRONT END DETAIL

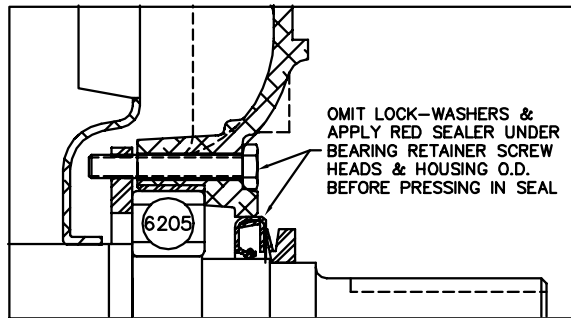

PULLEY END DETAIL

CUSTOMER IS RESPONSIBLE FOR DETERMINING THAT BALDOR'S PRODUCT WILL PERFORM SUITABLY IN THE INTENDED APPLICATION.

REV. DESC: REPLACE 35SB0008 W/35SB2081 & 35BA4010 IN MECH DWG		
REV. LTR: E	VERSION: 05	TDR: 000000969661
FILE: \AAA\00092\923	REVISED: 02:47:45 03/07/2016	BY: FPJFEGO
MTL: -		

BALDOR

STD HORZ 56C TEFC 35M WD (S/P #9)

SH 1 of 1