



RELATED PRODUCTS

Dodge Snap-On End Covers ENHANCED SEALING / SAFER WORK ENVIRONMENT

Housing Designed For Snap-On End Cover

GT and GTM bearings contain a machined groove in the housing to accommodate a snap-on style polymer end cover. The end cover provides additional protection from the environment and creates a safer working environment for employees maintaining equipment. The snap-on style end cover incorporates an additional lip on the mounting surface for a more rigid fit within the housing and enhanced sealing. The design is more durable than a blot-on style that uses the grease fitting to secure the cover in place and can be easily knocked off the bearing housings. Closed and open end covers are available.

- Available as a standard feature for GT/GTM
- Machined groove in housing accommodates snap-on style polymer end cover
- Extended lip on the outer diameter of end cover provides a secure fit and positive sealing
- Provides additional layer of protection in harsh environments
- Creates a safer work environment for employees
- OSHA approved yellow
- Closed and open end covers available

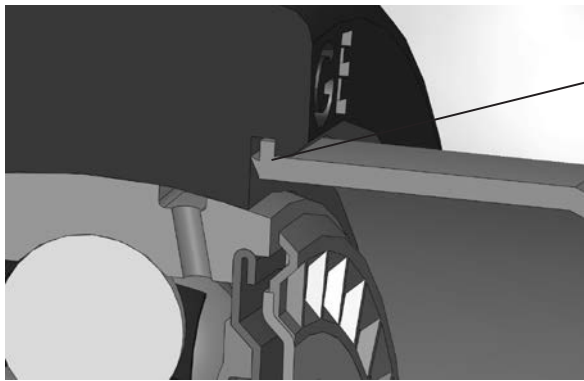

Extended lip provides a secure fit and positive sealing



RELATED PRODUCTS



Extreme Duty Ball Bearing END CLOSURES

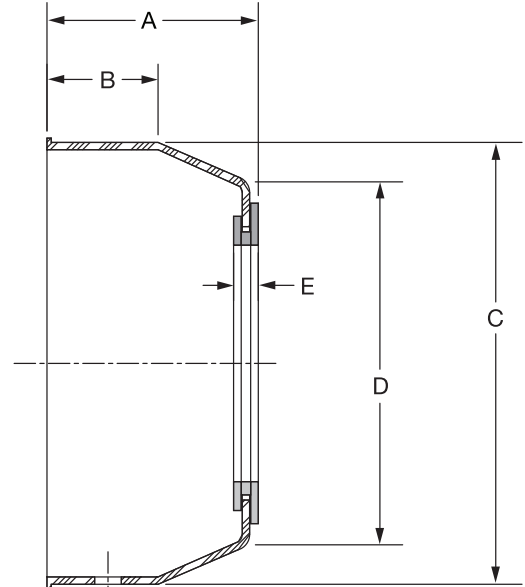
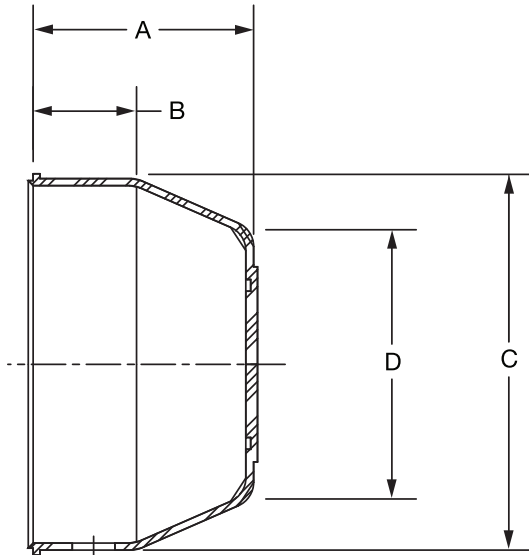

Series	Closed End Closure	
	Part Number	Description
204	128280	EC-204-Y
205	128281	EC-205-Y
206	128282	EC-206-Y
207	128283	EC-207-Y
208	128284	EC-208-Y
209	128285	EC-209-Y
210	128286	EC-210-Y
211	128277	EC-211-Y
212	128278	EC-212-Y

Open End Closure		
Shaft Size	Part Number	Description
3/4	128350	ECO-012-Y
20mm	128363	ECO-20M-Y
1	128351	ECO-100-Y
25mm	128364	ECO-25M-Y
1-3/16	128352	ECO-103-Y
1-1/4	128353	ECO-104S-Y
30mm	128365	ECO-30M-Y
1-1/4	128355	ECO-104-Y
1-7/16	128354	ECO-107-Y
35mm	128366	ECO-35M-Y
1-1/2	128356	ECO-108-Y
40mm	128367	ECO-40M-Y
1-11/16	128357	ECO-111-Y
45mm	128368	ECO-45M-Y
1-15/16	128358	ECO-115-Y
50mm	128369	ECO-50M-Y

FEATURES/BENEFITS PAGE B5-2	HOW TO ORDER/NOMENCLATURE PAGE B5-4	SELECTION PAGE B5-5	SELECTION/DIMENSIONS PAGE B5-8
--------------------------------	--	------------------------	-----------------------------------



RELATED PRODUCTS

Open Cover Extreme Duty Dimensions

Series	Shaft Size	A	B	C	D	E
204	3/4	1-3/16	17/32	1-29/32	1-3/8	3/16
	20mm	30.2	13.5	48.4	35.1	4.9
205	1	1-1/4	17/32	2-11/64	1-39/64	3/16
	25mm	31.8	13.5	55.1	40.9	4.9
206	1-3/16	1-25/64	9/16	2-1/2	31/32	3/16
	1-1/4					
	30mm	35.3	14.2	63.5	50.0	4.9
207	1-1/4	1-17/32	11/16	2-29/32	2-5/16	3/16
	1-7/16					
	35mm	38.9	17.5	73.9	58.9	4.9
208	1-1/2	1-19/32	11/16	3-5/16	2-49/64	13/64
	40mm	40.6	17.5	84.1	70.1	5.1
209	1-11/16	1-21/32	23/32	3-1/2	2-7/8	13/64
	45mm	41.9	18.3	88.9	72.9	5.1
210	1-15/16	1-23/32	29/32	3-5/8	3	13/64
	50mm	43.7	23.1	91.4	76.2	5.1

Closed Cover Extreme Duty Dimensions

Series	A	B	C	D
204	1-1/8	17/32	1-29/32	1-3/8
	28.7	13.5	48.4	35.1
205	3/16	17/32	2-11/64	1-39/64
	30.2	13.5	55.1	40.9
206	1-21/64	9/16	2-1/2	31/32
	33.8	14.2	63.5	50.0
207	1-15/32	11/16	2-29/32	2-5/16
	37.3	17.5	73.9	58.9
208	1-35/64	11/16	3-5/16	2-49/64
	39.1	17.5	84.1	70.1
209	1-19/32	23/32	3-1/2	2-7/8
	40.4	18.3	88.9	72.9
210	1-21/32	29/32	3-5/8	3
211	42.2	23.1	91.4	76.2
	1-51/64	31/32	3-15/16	3-19/64
	45.5	24.6	100.1	83.6
212	1-29/32	1	4-3/8	3-21/32
	48.3	25.4	111.3	92.7

RELATED PRODUCTS



DODGE Ball Bearing End Covers

- Fits DODGE cast iron housed ball bearings: Pillow Blocks, 2 and 4-Bolt flanges, and Take-Up bearings
- Injected molded, impact resistant, OSHA safety yellow end covers meet requirements for exposed rotating shafts
- Stainless steel “C” washer for gripping power
- No modification or machining of existing housings required
- Concentric knockout grooves on inside of end cover for thru-shaft
- DODGE six digit part number and description embossed inside
- Operating temperature to 250° F
- For no relubrication/sealed for life applications (-NL), part number **430020** hex head plug is available



Nomenclature

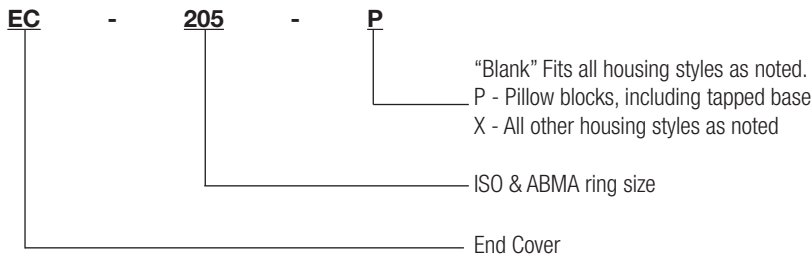

Series	Pillow Blocks Std, U, B	Tapped Base PB	2-Bolt Flange	Flanged Bracket	4-Bolt Flange	Piloted Flange (FC)	Narrow Slot Take-Up	Wide Slot Take-Up
203	X		X		X			
204	X	X	X	X	X		X	X
205	X	X	X	X	X		X	X
206	X	X	X	X	X	@	X	X
207	X	X	X	X	X	@	X	X
208	X	X	X		X	@	X	X
209	X	X	X		X	@	X	X
210	X	X	X	X	X	@	X	X
211	X	X	X		X	NA	X	X
212	X		X		X	NA	X	X
214	X				X	NA		X
215	X				X			X
216	X				X	X		X
218	X				X	X		

* = Will not fit LF, LFT, SCHB, HNGR & CYL
 @ = Some modification required

NA = Will not fit
 X = Will fit

FEATURES/BENEFITS PAGE B5-2	HOW TO ORDER/NOMENCLATURE PAGE B5-4	SELECTION PAGE B5-5	SELECTION/DIMENSIONS PAGE B5-8
--------------------------------	--	------------------------	-----------------------------------



RELATED PRODUCTS

Thin Wall Adapter Ball Bearings

BALL BEARING END COVERS FOR PILLOW BLOCKS & TAPPED BASE UNITS

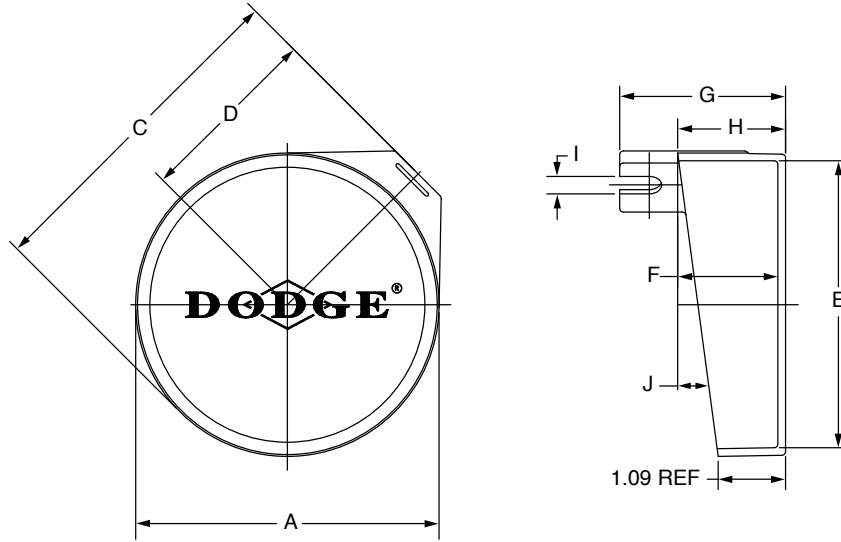

Series	Shaft Size		Part Number	Description
	GT	GTM		
203	1/2 & 5/8 17mm	-----	128200	EC-203-P
204	1/2 - 3/4 20mm	-----	128202	EC-204-P
205	7/8 - 1 25mm	-----	128204	EC-205-P
206	1-1/16 - 1-1/4 30mm	1 25mm	128206	EC-206-P
207	1-1/4 - 1-7/16 35mm	1-3/16 - 1-1/4 30mm	128208	EC-207-P
208	1-1/2 & 1-5/8 40mm	1-7/16 35mm	128210	EC-208-P
209	1-5/8 - 1-3/4 45mm	1-1/2 40mm	128212	EC-209-P
210	1-15/16 & 2 50mm	1-11/16 & 1-3/4 45mm	128214	EC-210-P
211	2 - 2-1/4 55mm	1-15/16 & 2 50mm	128216	EC-211-P
212	2-1/4 & 2-7/16 60mm	2-3/16 & 2-1/4 55mm	128218	EC-212-P

For no re-lube (-NL) applications, part number **430020**, hex head plug is available

RELATED PRODUCTS



Thin Wall Adapter Ball Bearings BALL BEARING END COVERS FOR PILLOW BLOCKS & TAPPED BASE UNITS

Bearing Reference Guide

ULTRA KLEEN

E-Z KLEEN

Extreme Duty

Setscrew Ball Bearing

GRIP TIGHT

D-LOK Ball Bearing

Series	Shaft Size		Weight lbs gm	A	B	C	D	E	F	G	H	I	J
	GT	GTM											
203	1/2 & 5/8 17mm	-----	0.02 10	1-25/32 45.2	1-43/64 42.5	2-7/64 53.6	1-3/32 27.8	1-41/64 41.7	49/64 19.4	1-29/64 36.9	29/32 23.0	1/4 6.4	9°
204	1/2 - 3/4 20mm	-----	0.03 15	2-3/64 52.0	1-27/32 46.8	2-37/64 65.5	1-19/64 32.9	1-55/64 47.2	1-1/64 25.8	1-49/64 44.8	1-5/32 29.4	5/16 7.9	11°
205	7/8 - 1 25mm	-----	0.05 24	2-3/8 60.3	2-3/16 55.6	2-13/16 71.4	1-3/16 30.2	2-5/32 54.8	1-1/16 27.0	1-7/8 47.6	1-7/32 31.0	11/32 8.7	9°
206	1-1/16 -1-1/4 30mm	1 25mm	0.08 36	2-47/64 69.5	2-17/32 64.3	3-21/64 84.5	1-45/64 43.3	2-1/2 63.5	1-15/64 31.4	2-5/32 54.8	1-13/32 35.7	23/64 9.1	9°
207	1-1/4 -1-7/16 35mm	1-3/16 -1-1/4 30mm	0.12 53	3-1/4 82.6	3 76.2	3-51/64 96.4	1-29/32 48.4	3-1/64 76.6	1-5/16 33.3	2-11/32 59.5	1-31/64 37.7	3/8 9.5	7° 30'
208	1-1/2 & 1-5/8 40mm	1-7/16 35mm	0.14 64	3-3/8 85.7	3-1/8 79.4	4 101.6	2-1/16 52.4	3-7/64 79.0	1-19/64 32.9	2-13/16 71.4	1-1/2 38.1	27/64 10.7	6°
209	1-5/8 -1-3/4 45mm	1-1/2 40mm	0.16 73	3-11/16 93.7	3-15/32 88.1	4-17/64 108.3	2-11/64 55.2	3-13/32 86.5	1-21/64 33.7	2-21/64 59.1	1-17/32 38.9	25/64 9.9	7°
210	1-15/16 & 2 50mm	1-11/16 & 1-3/4 45mm	0.18 82	3-7/8 98.4	3-37/64 90.9	4-1/2 114.3	2-19/32 65.9	3-37/64 90.9	1-23/64 34.5	2-1/2 63.5	1-9/16 39.7	31/64 12.3	9°
211	2 - 2-1/4 55mm	1-15/16 & 2 50mm	0.24 108	4-27/64 112.3	4 101.6	5-1/16 128.6	2-19/32 65.9	4-1/8 104.8	1-13/32 35.7	2-37/64 65.5	1-5/8 41.3	29/64 11.5	7°
212	2-1/4 & 2-7/16 60mm	2-3/16 & 2-1/4 55mm	0.27 124	4-59/64 125.0	4-15/32 113.5	5 29/64 138.5	2-3/4 69.9	4-39/64 117.1	1-17/32 38.9	2-11/16 68.3	1-3/4 44.5	13/32 10.3	8°

FEATURES/BENEFITS PAGE B5-2	HOW TO ORDER/NOMENCLATURE PAGE B5-4	SELECTION PAGE B5-5	SELECTION/DIMENSIONS PAGE B5-8
--------------------------------	--	------------------------	-----------------------------------

SELECTION/DIMENSIONS



Thin Wall Adapter Ball Bearings

BALL BEARING END COVERS FOR MOUNTED UNITS OTHER THAN PILLOW BLOCKS & TAPPED BASE UNITS

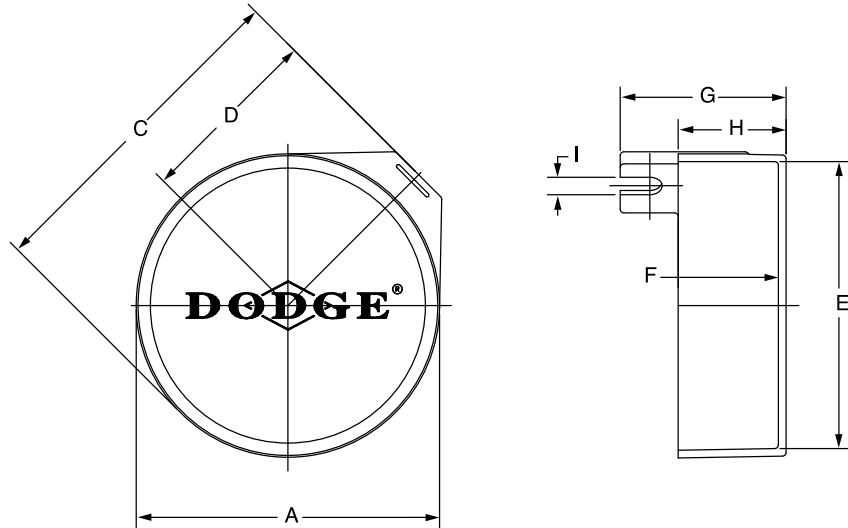

Series	Shaft Size		Part Number	Description
	GT	GTM		
203	1/2 & 5/8 17mm	-----	128201	EC-203-X
204	1/2 - 3/4 20mm	-----	128203	EC-204-X
205	7/8 - 1 25mm	-----	128205	EC-205-X
206	1-1/16 - 1-1/4 30mm	1 25mm	128207	EC-206-X
207	1-1/4 - 1-7/16 35mm	1-3/16 - 1-1/4 30mm	128209	EC-207-X
208	1-1/2 & 1-5/8 40mm	1-7/16 35mm	128211	EC-208-X
209	1-5/8 - 1-3/4 45mm	1-1/2 40mm	128213	EC-209-X
210	1-15/16 & 2 50mm	1-11/16 & 1-3/4 45mm	128215	EC-210-X
211	2 - 2-1/4 55mm	1-15/16 & 2 50mm	128217	EC-211-X
212	2-1/4 & 2-7/16 60mm	2-3/16 & 2-1/4 55mm	128219	EC-212-X

Note: Above end covers will not fit the LF and LFT bearings
 For no re-lube (-NL) applications, part number **430020**, hex head plug is available

FEATURES/BENEFITS PAGE B5-2	HOW TO ORDER/NOMENCLATURE PAGE B5-4	SELECTION PAGE B5-5	RELATED PRODUCTS PAGE B5-70
--------------------------------	--	------------------------	--------------------------------

SELECTION/DIMENSIONS



Thin Wall Adapter Ball Bearings

BALL BEARING END COVERS FOR MOUNTED UNITS OTHER THAN PILLOW BLOCKS & TAPPED BASE UNITS

Bearing Reference Guide

ULTRA KLEEN

E-Z KLEEN

Extreme Duty

Setscrew Ball Bearing

GRIP TIGHT

D-LOK Ball Bearing

Series	Shaft Size		Weight lbs gm	A	B	C	D	E	F	G	H	I
	GT	GTM										
203	1/2 & 5/8 17mm	-----	0.02 10	1-51/64 45.6	1-43/64 42.5	2-13/64 56.0	1-3/16 30.2	1-41/64 41.7	51/64 20.2	1-29/64 36.9	15/16 23.8	1/4 6.4
204	1/2 - 3/4 20mm	-----	0.03 15	2-7/32 56.4	2 50.8	2-47/64 69.5	1-25/64 35.3	2-1/32 51.6	1-1/64 25.8	1-13/16 46.0	1-5/32 29.4	5/16 7.9
205	7/8 - 1 25mm	-----	0.05 24	2-3/8 60.3	2-3/16 55.6	3-3/64 77.4	1-19/32 40.5	2-5/32 54.8	1-1/64 25.8	1-53/64 46.4	1-11/64 29.8	11/32 8.7
206	1-1/16 -1-1/4 30mm	1 25mm	0.08 36	2-47/64 69.5	2-17/32 64.3	3-21/64 84.5	1-45/64 43.3	2-1/2 63.5	1-3/16 30.2	2-1/16 52.4	1-23/64 34.5	23/64 9.1
207	1-1/4 -1-7/16 35mm	1-3/16 -1-1/4 30mm	0.12 53	3-1/4 82.6	3 76.2	3-27/32 97.6	1-31/32 50.0	3-1/64 76.6	1-11/32 34.1	2-11/32 59.5	1-17/32 38.9	3/8 9.5
208	1-1/2 & 1-5/8 40mm	1-7/16 35mm	0.14 64	3-3/8 85.7	3-1/8 79.4	4 101.6	2-1/16 52.4	3-7/64 79.0	1-19/64 32.9	2-13/32 61.1	1-1/2 38.1	27/64 10.7
209	1-5/8 -1-3/4 45mm	1-1/2 40mm	0.16 73	3-11/16 93.7	3-15/32 88.1	4-17/64 108.3	2-11/64 55.2	3-13/32 86.5	1-23/64 34.5	2-21/64 59.1	1-17/32 38.9	25/64 9.9
210	1-15/16 & 2 50mm	1-11/16 & 1-3/4 45mm	0.18 82	3-7/8 98.4	3-37/64 90.9	4-1/2 114.3	2-21/64 59.1	3-9/16 90.5	1-23/64 34.5	2-33/64 63.9	1-9/16 39.7	31/64 12.3
211	2 - 2-1/4 55mm	1-15/16 & 2 50mm	0.24 108	4-27/64 112.3	4 101.6	5-1/16 128.6	2-19/32 65.9	4-1/8 104.8	1-29/64 36.9	2-37/64 65.5	1-21/32 42.1	29/64 11.5
212	2-1/4 & 2-7/16 60mm	2-3/16 & 2-1/4 55mm	0.27 124	4-59/64 125.0	4-15/32 113.5	5 15/32 138.9	2-3/4 69.9	4-39/64 117.1	1-35/64 39.3	2-11/16 68.3	1-3/4 44.5	13/32 10.3

FEATURES/BENEFITS PAGE B5-2	HOW TO ORDER/NOMENCLATURE PAGE B5-4	SELECTION PAGE B5-5	RELATED PRODUCTS PAGE B5-70
--------------------------------	--	------------------------	--------------------------------



RELATED PRODUCTS

Thin Wall Adapter Ball Bearings BALL BEARING END COVERS FOR MOUNTED UNITS 214 SERIES AND LARGER

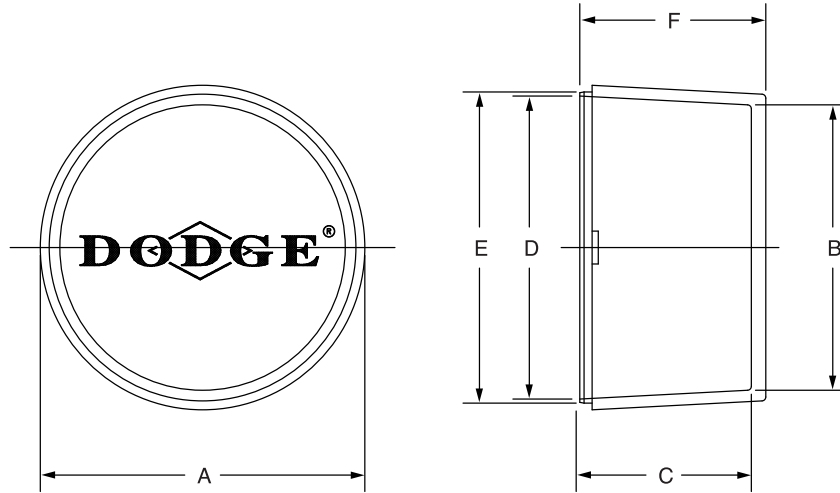

Series	Shaft Size		Part Number	Description
	GT	GTM		
214	2-11/16 70mm	2-7/16 & 2-1/2 65mm	128220	EC-214
215	2-15/16 75mm	2-11/16 70mm	128221	EC-215
216	-----	2-15/16 & 3 75mm	128222	EC-216
218	----- 90mm	3-7/16 & 3-1/2 85mm	128223	EC-218

Series	Shaft Size		Weight lbs gm	A	B	C	D	E		F
	GT	GTM						min.	max.	
214	2-11/16 70mm	2-7/16 & 2-1/2 65mm	0.33	4-15/16	4-11/32	2-39/64	4-39/64	4.737	4.741	2-53/64
			151	125.4	110.3	66.3	117.1	120.3	120.4	71.8
215	2-15/16 75mm	2-11/16 70mm	0.36	5-3/32	4-31/64	2-29/64	4-3/4	4.940	4.944	2-7/8
			164	129.4	113.9	62.3	120.7	125.5	125.6	73.0
216	-----	2-15/16 & 3 75mm	0.44	5-9/16	4-59/64	2-47/64	5-13/64	5.346	5.350	2-63/64
			201	141.3	125.0	69.5	132.2	135.8	135.9	75.8
218	----- 90mm	3-7/16 & 3-1/2 85mm	0.57	6-5/16	5-41/64	2-27/32	5-15/16	6.096	6.100	3-3/32
			257	160.3	143.3	72.2	150.8	154.8	154.9	78.6