

**MADERA™ FloWise® 16-1/2" HIGH 1.1 GPF  
FLUSHOMETER TOILET SYSTEM**

- ❑ **3043.711** 1.1 gpf 16-1/2" High Top Spud Bowl and Selectronic® Exposed AC Flush Valve

**BOWL:**

- Floor mount elongated flushometer valve toilet
- Vitreous china
- High Efficiency. Operates in the range of 1.1 gpf to 1.6 gpf (4.2 Lpf to 6.0 Lpf)
- 16-1/2" rim height for accessible application
- Powerful direct-fed siphon jet action
- Fully glazed 2-1/8" trapway
- Condensation channel
- 10" or 12" rough-in
- 10" x 12" water surface area
- 1-1/2" inlet spud
- 100% factory flush tested
- Less toilet seat
- Model 3043.001

**SELECTRONIC® FLUSH VALVE:**

- Self-Cleaning Piston with integral wiper spring significantly reduces clogging and maintenance
- Selectronic® Proximity System with universal sensor provides hygienic, "hands free" operation
- State-of-the-Art Electronics prevent ghost flushing
- Dezincification Resistant semi-red brass alloy
- Fully Mechanical Manual Override Button can flush the valve without power
- Fail-Safe: Valve automatically closes upon loss of power or water pressure and does not need to be reset
- Adjustable Sanitary Flush cleans the fixture & maintains the trap seal.
- Chemical Resistant EPDM Seals for extended life
- Adjustable Tailpiece for rough-in flexibility
- Can be installed left or right handed
- Includes Class 2 UL certified universal hard-wired AC transformer
- Optional cover plate only required for installation from the front
- Model 6067.111

**Includes:**

- 047007-0070A Inlet Spud (furnished with bowl)
- 481310-100 2 Bolt caps with retainers (furnished with bowl)
- 1" I.P.S. angle stop with back-flow protection and vandal resistant cap
- 1" Sweat solder kit including cover tube and wall flange
- 1-1/2" High back pressure vacuum breaker, spud coupling and flange



SEE REVERSE FOR ROUGHING-IN DIMENSIONS

**High-Efficiency Toilet System**

- 31.3% water savings when compared to 1.6 gpf toilet systems

**System MaP\* Score:**

- 1,000 grams of miso @ 1.1 gpf

\* Maximum Performance (MaP) testing performed by IAPMO R&T Lab. MaP Report conducted by Veritec Consulting, Inc. and Koeller and Company.

**Operating Pressure:**

25 psi (flowing) - 80 psi (static)

**Flow Requirement:**

25gpm (94.6 L/min.)

**Nominal Fixture Dimensions:**

718 x 356 x 419mm (28-1/4" x 14" x 16-1/2")

**To Be Specified:**

- ❑ Color:  White
- ❑ Seat:
  - ❑ American Standard #5901.100 Heavy duty open front less cover
  - ❑ American Standard #5905.100 Extra heavy duty open front less cover





**Fixture Compliance Certifications -  
Meets or Exceeds the Following Specifications:**

- ASME A112.19.2-2008 / CSA B45.1-08 for Vitreous China Fixtures

**Valve Listings:**

- ASSE 1037
- ANSI/ASME A112.19.2
- ADA Compliant

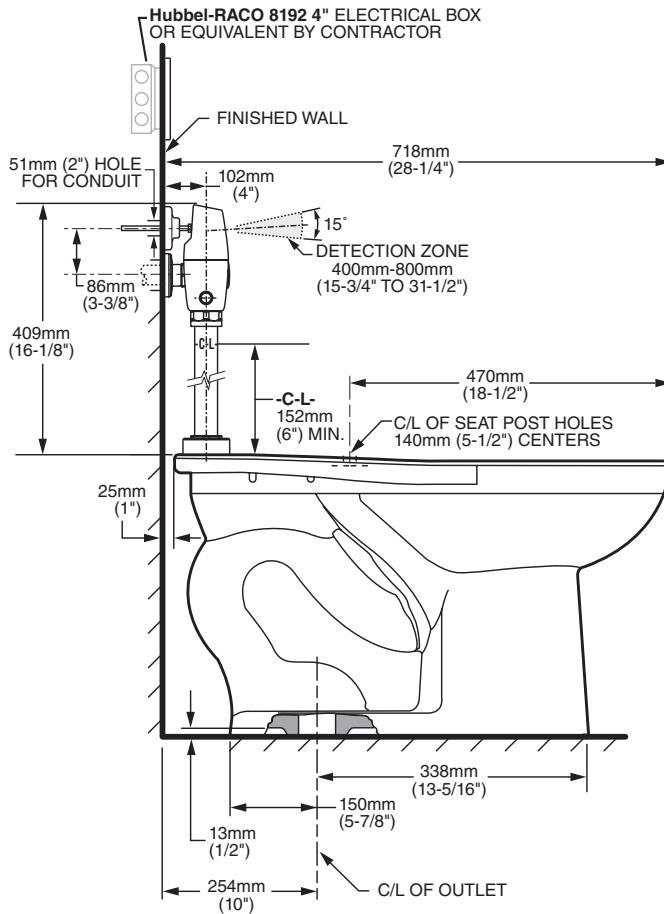

\*Note: The Critical Line (-C-L) on Vacuum Breaker must typically be a minimum of 152mm (6") above fixture. Consult Codes for details.

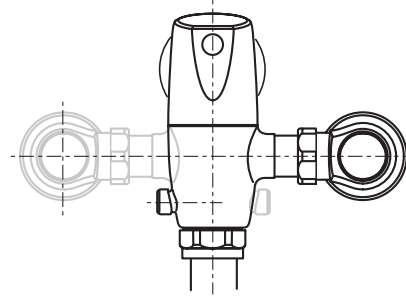
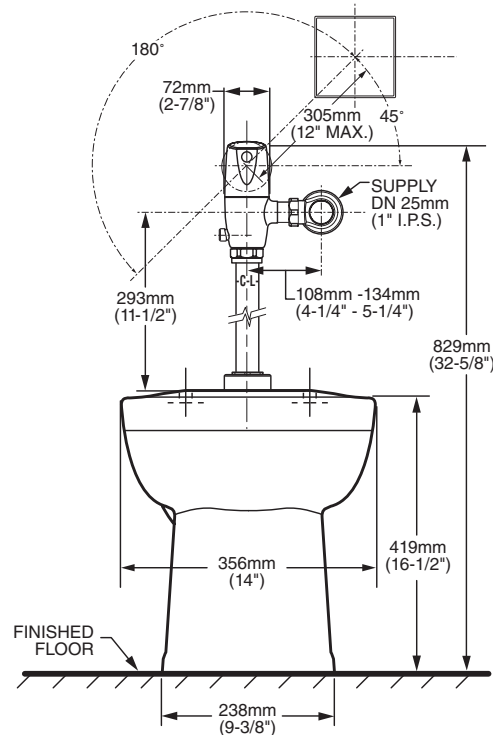

VALVE LEFT or RIGHT HAND INSTALLATION



**MEETS THE AMERICANS WITH DISABILITIES ACT GUIDELINES  
AND ANSI A117.1 REQUIREMENTS FOR ACCESSIBLE AND USABLE  
BUILDING FACILITIES - CHECK LOCAL CODES.**

**NOTES:**

TO COMPLY WITH AREA CODE GOVERNING THE HEIGHT OF VACUUM BREAKER ON THE FLUSHOMETER VALVE, THE PLUMBER MUST VERIFY DIMENSIONS SHOWN FOR SUPPLY ROUGHING. THIS TOILET DESIGNED TO ROUGH-IN AT A MINIMUM DIMENSION OF 254MM (10") AND A MAXIMUM DIMENSION OF 305MM (12") FROM FINISHED WALL TO C/L OF OUTLET.

**IMPORTANT:** Dimensions of fixtures are nominal and may vary within the range of tolerances established by ANSI Standard A112.19.2. These measurements are subject to change or cancellation. No responsibility is assumed for use of superseded or voided pages.