

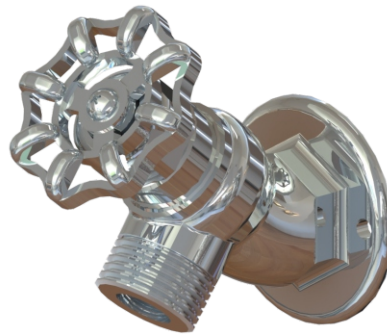

Hose & Supply Boxes 8120-LF Series

Hose Valves



8120CP-LF



8125CR-LF

Fixture May Show Some Available Options

Please visit www.acorneng.com for most current specifications.

Acorn Hose Valves are CUPC certified by IAPMO for U.S. and Canada. Hose valves are recommended for installation in indoor and outdoor locations not subject to freezing. Hose valves include a heavy rough brass body, furnished with a lockshield bonnet and removable loose key wheel handle. Valves close with the water pressure and feature a replaceable cartridge which contains all wearing parts including the seat. Inlet is 3/4" NPTI, outlet is 3/4" NPSH. Vacuum breakers are atmospheric type and conform to the requirements of ASSE Standard 1011. Hose valves meets the lead free requirements where the wetted surface of this product contacted by water contains less than 0.25% lead. Check local code authority for vacuum breaker requirements

Installation: The 8120-LF and 8121-LF, horizontally supplied valves have integral wall flanges and both are used indoor and outdoor. 8125-LF and 8126-LF, vertically standpipe valves are normally used in outdoor planting areas and often provided in a rough brass finish.

GUIDE SPECIFICATION

Provide and install Acorn Hose Valves model (specify model number) cartridge - operated hose valve with lock shield bonnet and removable loose key handle. Interior wall hose valves shall be polished chrome finish, exterior valves shall be rough chrome-plated.



Hose & Supply Boxes 8120-LF: Hose Valves

BASE MODEL NUMBER (Must Specify)

HOSE VALVE

BENT NOSE WITH FLANGE

- 8120-LF Less Vacuum Breaker
- 8120CP-LF Polished Chrome-Plated Less Vacuum Breaker
- 8120CR-LF Rough Chrome-Plated Less Vacuum Breaker
- 8121-LF With Vacuum Breaker
- 8121CP-LF Polished Chrome-Plated With Vacuum Breaker
- 8121CR-LF Rough Chrome-Plated With Vacuum Breaker

BENT NOSE

- 8125-LF Less Vacuum Breaker
- 8125CP-LF Polished Chrome-Plated Less Vacuum Breaker
- 8125CR-LF Rough Chrome-Plated Less Vacuum Breaker
- 8126-LF With Vacuum Breaker
- 8126CP-LF Polished Chrome-Plated With Vacuum Breaker
- 8126CR-LF Rough Chrome-Plated With Vacuum Breaker

Please visit www.acorneng.com for most current specifications.

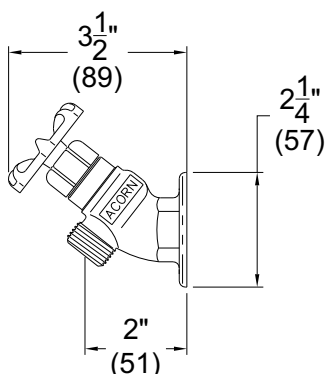

8120-LF

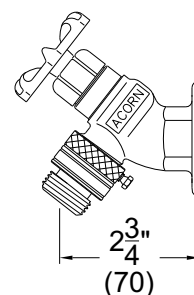

8121-LF

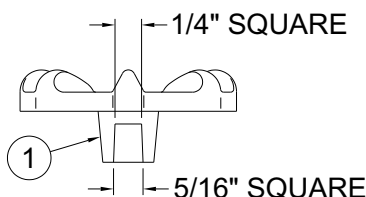

SCALE 2X

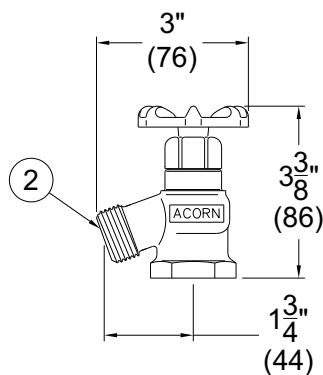

8125-LF

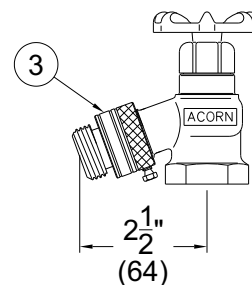

8126-LF

NOTES:

1. Wheel Handle (removable).
2. 3/4"-11.5 NHE Hose Connection.
3. Vacuum Breaker.

Important: Installation instructions and current rough-in are furnished with each fixture. Do not rough in without certified dimensions. Dimensions are subject to manufacturer's tolerance of plus or minus 1/4" and change without notice. Acorn assumes no responsibility for use of void or superseded data. © Copyright 2008 Acorn Engineering Company	
<p style="text-align: center;">Selection Summary</p> <p>Model No. & Option _____</p> <p>Quantity _____</p>	<p style="text-align: center;">Approved for Manufacturing</p> <p>Company _____ Title _____</p> <p>Signature _____ Date _____</p>