



(Fan/LED Light - 100 CFM)

	<p>4" Duct (Standard): 100 CFM/0.8 Sones @ 0.1 SP, 11 Watts 63 CFM/1.5 Sones @ 0.25 SP, 13 Watts</p>		
--	---	--	--

Description

Low noise ceiling mount ventilating Fan/LED Light rated for continuous running. Fan has been awarded ENERGY STAR® qualified. It is HVI, UL, and cUL certified, and can be used to comply with ASHRAE 62.2 Intermittent Local Exhaust, CA Title 24 requirements.

DC Motor/Blower

- Power rating of 120 volts/60Hz
- DC Brushless motor engineered to run continuously
- Motor equipped with thermal cutoff fuse
- Removable with permanently lubricated plug-in motor
- Built-in soft start function to increase bearings' life
- Automatically powers OFF when impeller is locked abnormally

Housing

- Galvanized steel body
- Detachable 4" diameter metal duct adapter
- Built-in backdraft damper
- Hanger bars included
- Easy installation

Grille

- Attractive design using ABS material
- Attaches directly to housing with torsion springs

Light

- (1)11-Watt LED lamp included
- Main light output 850 Lumens, 2700K

LED Indicator

- Turn the power switch on/off to operate on/off. LED indicator will be green when power is on

Warranty

- 3-year limited warranty

TYPICAL SPECIFICATION

Ventilation fan shall be Delta Breez model 100LED; ENERGY STAR qualified with DC brushless motor engineered to run continuously for a minimum 70,000 hours; airflow rating of 100 CFM and loudness rating of 1.5 sones at 0.1 static pressure as certified by the Home Ventilating Institute (HVI); power consumption of 13.6 Watts with efficiency rating of 7.3 CFM/Watt at 0.1" static pressure; fan will feature LED indicator running light, motor lock protection and self-compensating motor speed for intended airflow when static pressure is encountered. UL and cUL listed for tub/shower enclosure when used with GFCI-protected branch circuit wiring.

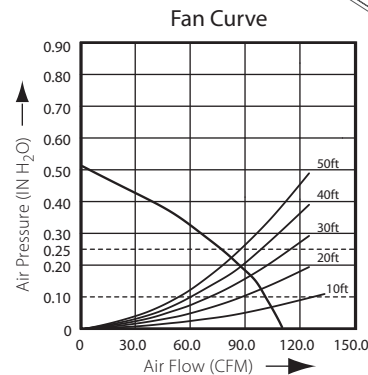
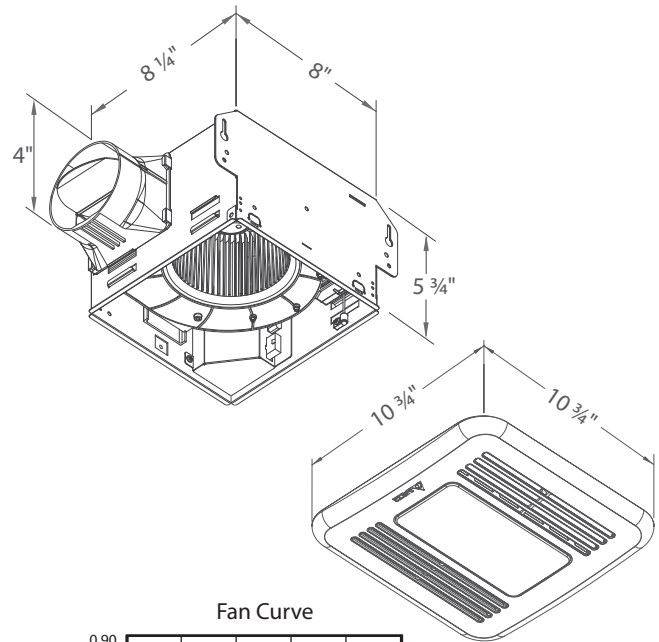

BreezGreenBuilder 100LED	4" Duct (Standard)	
Static Pressure (inches w.g.)	0.1	0.25
Air Flow (CFM)	100	72
Sones	1.5	1.5
Power Consumption (Watts)	13.6	11.6
Energy Efficiency (CFM/Watt)	7.3	6.2
Current (Amps)	0.35 Max	
Power Rating (V/Hz)	120 / 60	
LED Main Light (Watt)	13	

Model	Quantity	Comments	Project:
			Location:
			Architect:
			Engineer:
			Contractor:
			Submitted by:
			Date: