



# INSTRUCTIONS

PLEASE LEAVE A REVIEW WHERE YOU PURCHASED YOUR PRODUCT



LOCK OUT

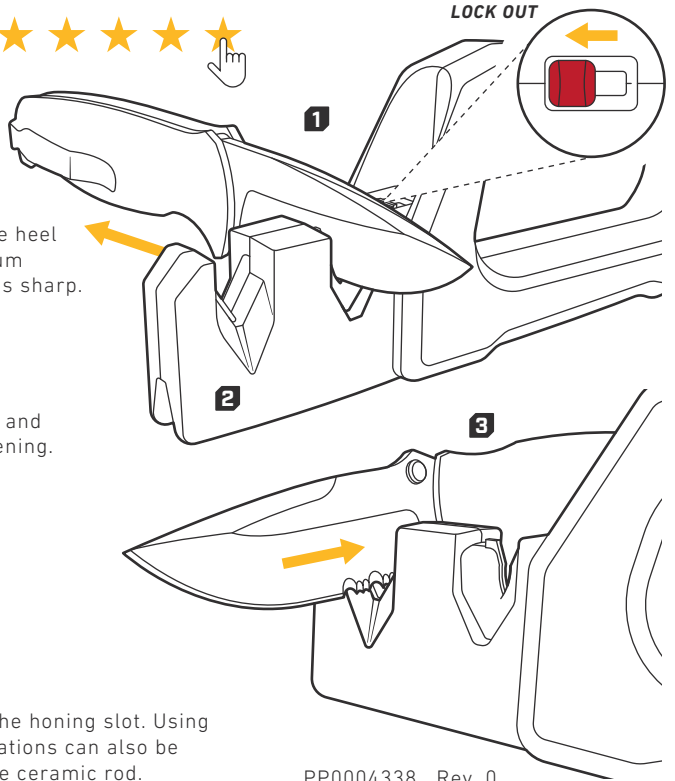

PP0004338 Rev. 0

## 1 KNIFE SHARPENING

Place knife in carbide sharpening slot at the heel of the blade. Pull knife through using medium pressure. Make multiple passes until edge is sharp.

### PRO TIP

Slide the red button left to activate Pivot Response. This allows the Convex Carbide mechanism to follow the curve of the blade and increase material removal for heavy sharpening.

## 2 HONING

Switch to the ceramic. Follow the same steps as 1 above.

## 3 SERRATIONS

Lay flat side of serrations onto the side of the honing slot. Using light pressure, pull the blade through. Serrations can also be touched up by nesting the serration onto the ceramic rod.

## 4 SCISSORS

Hold sharpener in hand and apply the rear carbide scissor sharpening slot onto the scissor cutting edge. Apply medium pressure and make multiple passes until edge is sharp. Sharpen only beveled side of scissor blade.

### PRO TIPS

Garden bypass pruners with single bevel can also be sharpened the same way.

Scissor sharpener can be removed from handle for convenient use.

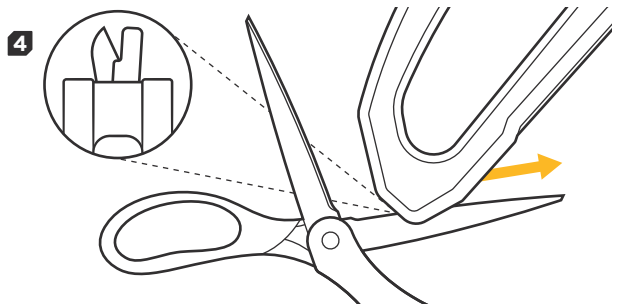

## 5 TOOLS

A. Heavy tool sharpening applications may require use of the diamond plate. Hold sharpener in hand and swipe diamond plate across tool cutting edge to remove damage. Finish using carbide if desired.

B. Hold sharpener in hand and apply the front carbide tool sharpening slot onto the cutting edge. Apply medium pressure and make multiple passes until edge is sharp.

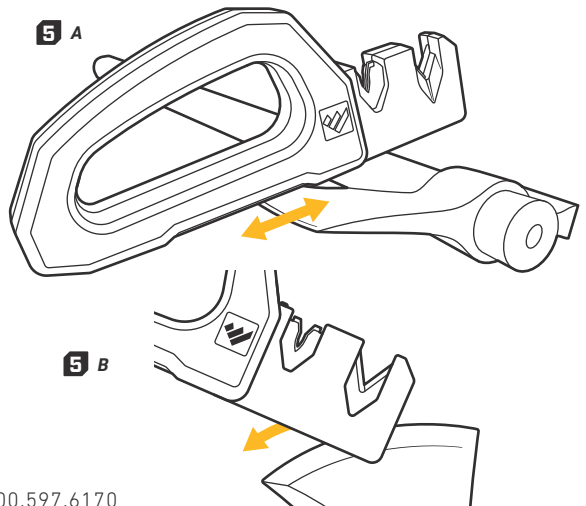

## QUESTIONS?

WorkSharpTools.com / 1.800.597.6170