

# WAYNE®

## Convertible Well Jet Pump Water Systems

Please read and save these instructions. Read carefully before attempting to assemble, install, operate or maintain the product described. Protect yourself and others by observing all safety information. Failure to comply with instructions could result in personal injury and/or property damage! Retain instructions for future reference.

### Operating Instructions and Parts Manual

### CWS Series

SPECIFICATIONS	
<b>POWER SUPPLY REQUIREMENTS</b>	120 or 230 V, 60 Hz
<b>MOTOR</b>	Split Phase
<b>HORSEPOWER</b>	1 HP ..... (CWS100) 3/4 HP ..... (CWS75) 1/2 HP.....(CWS50)
<b>LIQUID TEMPERATURE RANGE</b>	40° F- 120° F
<b>CUT IN PRESSURE</b>	30 PSI
<b>CUT OUT PRESSURE</b>	50 PSI

CONSTRUCTION	
<b>MOTOR HOUSE</b>	Cast Iron
<b>SEAL PLATE</b>	Cast Iron
<b>DIFFUSER</b>	Thermoplastic
<b>IMPELLER</b>	Thermoplastic
<b>SHAFT</b>	Carbon Steel
<b>PUMP SUCTION</b>	1-1/4 in. NPT
<b>PUMP DISCHARGE</b>	3/4 in. NPT

PERFORMANCE												
Model	HP	PSI	0 ft	10 ft	20 ft	30 ft	40 ft	50 ft	60 ft	70 ft	80ft	90 ft
CWS100	1	30	1056	948	846	750	642	516	384	294	234	180
		40	840	750	642	528	384	294	234	180	126	72
		50	588	444	330	264	234	180	126	72	-	-
CWS75	3/4	30	990	906	774	630	510	408	306	246	186	54
		40	780	630	510	408	306	246	186	114	54	-
CWS50	1/2	50	462	330	270	216	156	90	-	-	-	-
		30	900	780	690	570	456	348	270	180	90	-
		40	660	570	450	348	270	180	90	-	-	-
		50	408	300	210	150	60	-	-	-	-	-

\* Refer to Page 13 for Jet Assembly Part Numbers

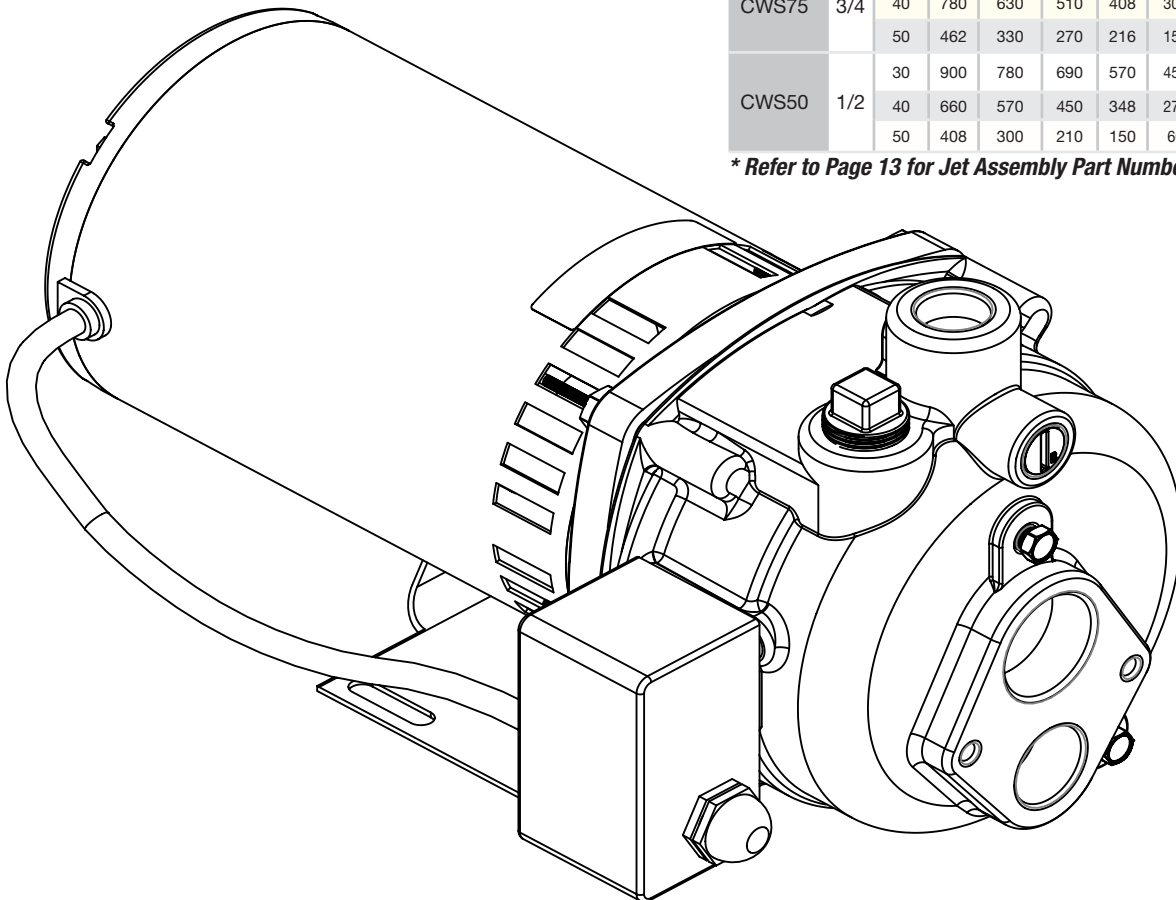

Intended for Indoor Use Only

# Operating Instructions and Parts Manual

## DESCRIPTION

Jet pumps are single stage domestic water pumps designed for pumping potable water in applications where the water is up to 90 feet below pump center line. A pressure switch is a standard feature. A built-in control valve is available on deep well pumps. Deep well pumps must be mounted to either a pre-charged, conventional type, or free standing pressure tank. A Wayne jet assembly is required (not included) for operation of this pump.

## UNPACKING

Inspect this unit before it is used. Occasionally, products are damaged during shipment. If the pump or components are damaged, return the unit to the place of purchase for replacement, or call Customer Support (800-237-0987).

## SAFETY SIGNAL WORDS

To help recognize this information, observe the following signal words/hazard classifications.

**⚠ DANGER** *Danger indicates an imminently hazardous situation which, if not avoided, WILL result in death or serious injury.*

**⚠ DANGER** *La mention Danger indique une situation dangereuse imminente qui, si elle n'est pas évitée, ENTRAÎNE la mort ou des blessures graves.*

**⚠ WARNING** *Warning indicates a potentially hazardous situation which, if NOT avoided, COULD result in death or serious injury.*

**⚠ AVERTISSEMENT** *La mention avertissement indique une situation potentiellement dangereuse qui, si elle n'est pas évitée, risque d'entraîner des lésions corporelles graves ou même la mort.*

**⚠ CAUTION** *Caution indicates a potentially hazardous situation which, if NOT avoided, MAY result in minor or moderate injury.*

**⚠ MISE EN GARDE** *La mention mise en garde indique une situation potentiellement dangereuse qui, si elle n'est pas évitée, pourrait entraîner des blessures mineures ou modérées.*

**NOTICE** *Notice indicates important information, that if not followed, may cause damage to equipment.*

**⚠** *This is the safety alert symbol. It is used to alert you to potential bodily injury hazards. Obey all safety messages that follow this symbol to avoid possible harm.*

**NOTE:** Information that requires special attention.

## GENERAL SAFETY INFORMATION

### CALIFORNIA PROPOSITION 65

## ⚠ WARNING

*This product can expose you to chemicals, including DEHP, which is known to the State of California to cause cancer, birth defects and reproductive harm. For more information, go to [www.P65Warnings.ca.gov](http://www.P65Warnings.ca.gov).*

## ⚠ AVERTISSEMENT

*Ce produit peut vous exposer à des produits chimiques, notamment du DOP, reconnus par l'État de Californie comme étant cancérigènes et à l'origine d'anomalies congénitales et de problèmes de l'appareil reproductif. Pour plus de renseignements, visiter le site [www.P65Warnings.ca.gov](http://www.P65Warnings.ca.gov).*

### GENERAL SAFETY

1. Read all manuals included with this product carefully. Be thoroughly familiar with the controls and the proper use of the equipment.
2. Know the pump application, limitations and potential hazards.



**⚠ WARNING** *Always install a pressure relief valve to match the system pressure rating and the maximum flow rate.*

**⚠ AVERTISSEMENT** *TOUJOURS installer une soupape de surpression correspondant à la pression nominale et au débit maximal du système.*

**⚠ DANGER** *Do not use to pump flammable or explosive fluids such as gasoline, fuel oil, kerosene, etc. Do not use in explosive atmospheres. Pump should be used to pump ONLY clear water. Failure to follow this warning will result in death or serious injury, and void warranty.*



**⚠ DANGER** *Ne pas utiliser pour pomper des fluides inflammables ou explosifs tels que l'essence, le mazout, le kérosène, etc. Ne pas utiliser dans des environnements explosifs. Pomper UNIQUEMENT de l'eau claire. Le non-respect de cet avertissement entraînera la mort ou des blessures graves, annuler la garantie..*

**REMINDER: Keep your dated proof of purchase for warranty purposes! Attach it to this manual or file it for safekeeping.**

**▲ WARNING** *Disconnect power and release all pressure from the system before attempting to install, service, relocate or perform any maintenance. Lock the power disconnect in the open (off) position. Tag out the power disconnect to prevent unexpected application of power.*

**▲ AVERTISSEMENT** *Débrancher de la source d'alimentation puis dissiper toute la pression du système avant d'essayer d'installer, de réparer, de déplacer ou de procéder à l'entretien. Verrouiller le sectionneur de courant en position ouverte (OFF). Étiqueter le sectionneur de courant pour éviter toute mise sous tension imprévue.*

3. Drain all water from the system before servicing.
4. Periodically inspect pump and system components. Perform routine maintenance as required (See Maintenance, page 8).

#### Personal Safety:

- a. Wear safety glasses at all times when working with pumps.
- b. Keep work area clean, uncluttered and properly lighted replace all unused tools and equipment.
- c. Keep visitors at a safe distance from work area.
5. Do not pump chemicals or corrosive liquids. Pumping these liquids shortens the life of the pumps seals and moving parts and will void the warranty. Pump ONLY clear water.
6. When installing pump, cover the well to prevent foreign matter from falling into well and contaminating the water and/or damaging internal mechanical pumping components.
7. Always test the water from the well for purity before use. Check with local health department for test procedure.
8. Complete pump and piping system MUST be protected against below freezing temperatures. Freezing temperatures could cause severe damage and void the warranty.
9. Do not run the pump dry or damage will occur and will void warranty.

**▲ WARNING** *This pump is designed for indoor installation only unless housed and protected from the elements. Failure to install indoors will significantly increase the risk of injury or death from electrical shock and void warranty.*



**▲ AVERTISSEMENT** *Cette pompe est conçue pour être installée à l'intérieur sauf si elle est abritée et protégée contre les intempéries. Ne pas l'installer à l'abri dans un local augmente considérablement le risque de blessure ou de mort par électrocution, annuler la garantie.*

**▲ WARNING** *All wiring should be performed by a licensed or certified electrician.*

**▲ AVERTISSEMENT** *Tout câblage doit être réalisé par un électricien agréé ou certifié.*

10. Make sure the line voltage and frequency of electrical current supply agrees with the motor wiring.
11. Do not attempt repairs to the electric motor. All repairs to the motor must be completed at a licensed or certified electrical motor repair shop.

**▲ WARNING** *Do not touch an operating motor. Modern motors are designed to operate at high temperatures.*

**▲ AVERTISSEMENT** *NE PAS toucher un moteur en marche. Les moteurs modernes sont conçus pour fonctionner à des températures élevées.*

12. Avoid kinking electrical cord and protect electrical cord from sharp objects, hot surfaces, oil and chemicals.
13. Keep fingers and foreign objects away from ventilation and other openings. Do not insert any objects into the motor.

**▲ WARNING** *Risk of electric shock! Never connect the green (or green/yellow) wire to a live terminal!*

**▲ AVERTISSEMENT** *Risque de choc électrique! Ne JAMAIS brancher le fil vert (ou vert et jaune) à une borne sous tension!*

14. Use wire of adequate size to minimize voltage drop at the motor.

**▲ DANGER** *Do not handle pump or pump motor with wet hands, when standing on a wet or damp surface or when standing in water. Fatal electrical shock will occur.*

**▲ DANGER** *NE PAS manipuler de pompe ou de moteur de pompe avec les mains humides ou debout sur une surface mouillée ou humide, ou dans l'eau. Ceci peut occasionner un choc électrique mortel.*

**▲ WARNING** *Pump motor is equipped with an automatic resetting thermal protector and may restart unexpectedly. Protector tripping is an indication of motor overheating because of operating pump at low heads (low discharge restriction), excessively high or low voltage, inadequate wiring, incorrect motor connections, excessive surrounding air temperature, inadequate ventilation, and/or defective motor or pump.*

**▲ AVERTISSEMENT** *Le moteur de la pompe est doté d'un protecteur thermique à réinitialisation automatique et pourrait redémarrer de manière imprévue. Le déclenchement du protecteur est une indication de surchauffe du moteur à cause d'une utilisation de la pompe à faible hauteur de chute (restriction de faible décharge), d'une tension excessivement haute ou basse, d'un câblage inadéquat, d'un branchement incorrect du moteur, d'une température ambiante excessive, d'une ventilation inadéquate ou d'une pompe ou d'un moteur défectueux.*

# Operating Instructions and Parts Manual

## PRE-INSTALLATION

### WATER SUPPLIES

The water supplies illustrated in Figure 16 (on page 13) are possible sources for water. These water supplies can be divided into two categories:

#### SURFACE WATER

Water from a lake, storage tank, stream, pond and cistern. This water is usually not fit for human consumption, but may be suitable for washing, irrigation or other household uses.

#### GROUND WATER

Water found in the water bearing stratum at various levels beneath the earth. Of all the fresh water found on earth only 3 percent is found on the surface and 97 percent is underground.

### WATER STORAGE

Tanks are required for these pumps to operate as designed.

#### TANKS - CONVENTIONAL STORAGE

The function of the tank is to store a quantity of water under pressure. When full, the tank contains approximately 2/3 water and 1/3 compressed air. The compressed air forces the water out of the tank when a faucet is opened. An air volume control automatically replaces air lost or absorbed into the water. The usable water, or draw-down capacity, of the tank is approximately 1/6 of the tanks total volume when operated on a 30/50 pressure setting (Figure 1).

#### TANKS - PRE-CHARGED STORAGE

A pre-charged storage tank has a flexible bladder or diaphragm that acts as a barrier between the compressed air and water. This barrier prevents the air from being absorbed into the water and allows the water to be acted on by compressed air at initially higher than atmospheric pressures (pre-charged). More usable water is provided than with a conventional type tank. Pre-charged tanks are specified in terms of a conventional tank. For example, a 20 gallon pre-charged tank will have the same usable water or draw-down capacity as a 40 gallon conventional tank, but the tank is smaller in size (Figure 1). Pre-charged to be set at 28 PSI with the tank empty of water.

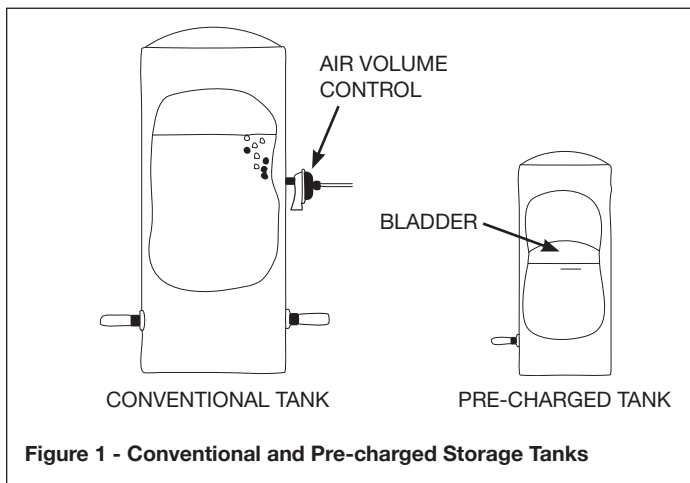

Figure 1 - Conventional and Pre-charged Storage Tanks

## INSTALLATION

### LOCATION

Select a location as close to the water supply as possible. Be sure to comply with any state or local codes regarding the placement of the pump. The equipment must be protected from the elements or voids warranty. A basement or heated pump house is a good location. Make sure the pump has proper ventilation. The temperature surrounding the pump is not to exceed 100° F (38°C) or nuisance tripping of the motor overload may occur.

**⚠ WARNING** *This pump is designed for indoor installation only, unless housed and protected from the elements. Failure to install indoors will significantly increase the risk of injury or death from electrical shock.*

**⚠ AVERTISSEMENT** *Cette pompe est conçue pour être installée à l'intérieur sauf si elle est abritée et protégée contre les intempéries. Ne pas l'installer à l'abri dans un local augmente considérablement le risque de blessure ou de mort par électrocution.*

### WELLS

A new well should be pumped clear of sand before installing the pump. Sand will damage the pumping parts and seal. The draw-down level of the well should not exceed the maximum rated depth for the pump. The capacity of the pump will be reduced and a loss of prime may occur.

### PIPING

Inlet piping may be copper, steel, or rigid PVC plastic.

**⚠ CAUTION** *Flexible pipe is prohibited on suction pipe (inlet pipe).*

**⚠ MISE EN GARDE** *Un tuyau flexible est interdit sur le tuyau d'aspiration (tuyau d'entrée).*

The pipe must be clean and free of rust or scale. Use a pipe joint compound on the male threads of the metal pipe. Plumber's seal tape should be used with plastic threads. All connections must be air tight to insure normal operation.

Slope all inlet piping upwards towards the pump to prevent trapping air. Unions or hose couplings can be installed near pump to facilitate removal for servicing or storage. A rubber hose installed between the water system and the house piping will reduce the noise transmitted to the house.

Plastic pipe can be used on all installations except 2 in. deep well jet. The 2 in. deep well jet requires 1-1/4 in. galvanized steel pipe and special machined couplings (1-13/16 in. O. D.).

The galvanized steel pipe and the couplings restrict the flow of return water back to the jet unless the couplings are machined.

---

## INSTALLATION (CONTINUED)

---

### PRESSURE SWITCH

The pressure switch provides for automatic operation. The pump starts when pressure drops to a cut-in setting. The pump stops when pressure reaches a cut-out setting. The pressure switch preset and is **NOT** adjustable.

### PIPE SIZES

Long horizontal pipe runs and an abundance of fittings and couplers decrease water pressure due to friction loss. See Chart 1, on page 5, to determine the proper pipe size.

### SHALLOW WELL INSTALLATION

A shallow well jet assembly can be used with the deep well pump when the pump is located a maximum of 25 ft vertically above the water level (see converting to shallow well pump on page 7). Shallow well installations have only one pipe between the pump and water supply (Figure 2).

### DRILLED WELL (FIGURE 16, PAGE 13)

1. Install a foot valve on the first section of pipe (Figure 2, Illustration A).
2. Lower the pipe into the well.
3. Add pipe until the foot valve is 5 feet below the lowest anticipated water level.

**▲ CAUTION** *The foot valve must be at least 18 in. from the bottom of the well or sand or sediment could be drawn into the system.*

**▲ MISE EN GARDE** *Le clapet de pied doit au moins être à 45,7 cm (18 po) du fond du puits, sinon du sable ou des sédiments pourraient être aspirés dans le système.*

4. After proper depth is reached, install a well seal or pitless adapter to support pipe and prevent surface water and other contaminants from entering well.
5. Slope the horizontal pipe upward toward the pump to eliminate trapping air. Sloping the pipe will also aid in priming the pump.

### DRIVEN WELL (FIGURE 16, PAGE 13)

- Drive the point several feet below the water table.

**NOTE:** A packer type foot valve can be installed in the well (Figure 2, Illustration B). This type of foot valve allows the piping to be filled with water when priming and makes the inlet pipe much easier to test for leaks. Follow the manufacturer's instructions when installing the packer type foot valve.

As an alternative, an in-line check valve can be used with a driven well (Figure 2, Illustration C). The pipe between the check valve and the water level will always be under a vacuum.

Leaking joints or couplings will allow air to leak into the pipe and cause abnormal pump operation. Make sure to use pipe joint compound on all male pipe threads.

### DUG WELL, CISTERN, LAKE AND SPRING INSTALLATION (FIGURE 16, PAGE 13)

- Install a foot valve on inlet pipe and lower into water.

**▲ CAUTION** *The foot valve must be at least 18 in. from the bottom of the well or sand or sediment could be drawn into the system.*

**▲ MISE EN GARDE** *Le clapet de pied doit au moins être à 45,7 cm (18 po) du fond du puits, sinon du sable ou des sédiments pourraient être aspirés dans le système.*

**NOTE:** When a lake is used as a water supply, make sure the inlet pipe is deep enough to be submerged at all times.

Slope the horizontal piping upward toward the pump to prevent trapping air. The pipe must be removed during winter months or protected against freezing.

Protect the pipe from damage from swimmers and boats.

**▲ WARNING** *Install a screen around the inlet pipe to prevent the entrapment of swimmers, wildlife and debris.*

**▲ AVERTISSEMENT** *Installer un écran autour du tuyau d'entrée pour éviter de piéger des nageurs, des animaux et des débris.*

---

## INSTALLATION (CONTINUED)

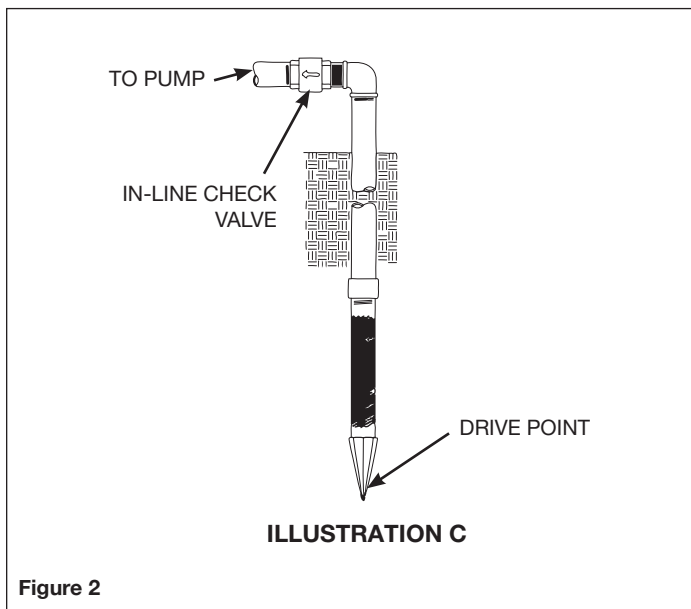
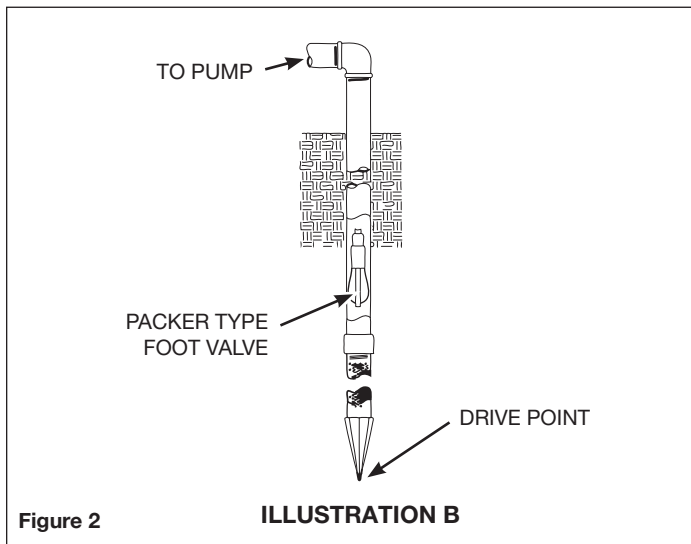
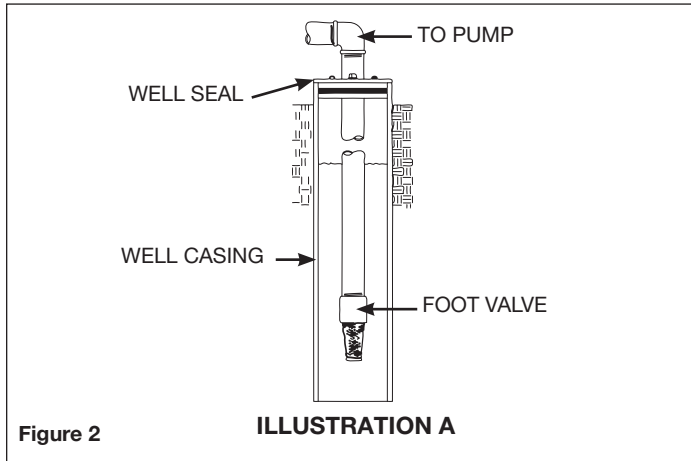

## DEEP WELL INSTALLATION

### DRILLED WELL (4 IN. OR LARGER) WITH TWO PIPE JET (FIGURE 16, ON PAGE 13 AND FIGURE 3, BELOW)

1. Assemble a 1-1/4 in. foot valve (not included) to the jet body. A 1-1/4 in. coupling is required to connect the larger pipe to the jet assembly.
2. Connect the 1 in. pipe threads into the smaller opening in the jet body.
3. Lower the jet into the well. Add pipe as needed. Be sure to use pipe joint compound, or plumber's seal tape on all male threads.
4. Position the jet 10 - 20 feet below the lowest anticipated water level, but never closer than 5 feet from the bottom of the well, if possible.
5. Install a well seal to support the pipe and prevent surface water and other contaminants from entering the well.
6. Install the horizontal pipe from the well to the pump. Piping from the vertical well pipe to the pump should never be smaller than the well pipes.
7. Slope both pipes upward toward the pump to prevent trapping air. If the horizontal distance exceeds 25 feet, see Chart 1, on page 7 for the recommended pipe sizes.

### DUG WELL, CISTERN, LAKE AND SPRING WITH TWO PIPE JET (FIGURE 16, PAGE 13)

1. Install a 1-1/4 in. foot valve (not included) to the jet body. A 1-1/4 in. coupling is required to connect the larger pipe to the jet assembly.
2. Connect the 1 in. pipe threads into the smaller opening in the jet body.
3. Lower the jet into the water below the lowest anticipated water level, but never closer than 18 in. from the bottom. Sand or debris may be drawn into the system if the jet is too close to the bottom.
4. Provide protection for the jet and pipes against damage from boats or swimmers if a lake is used for the water supply.

**▲ WARNING** *Install a screen around the inlet pipe to prevent the entrapment of swimmers, wildlife and debris.*

**▲ AVERTISSEMENT** *Installer un écran autour du tuyau d'entrée pour éviter de piéger des nageurs, des animaux et des débris.*

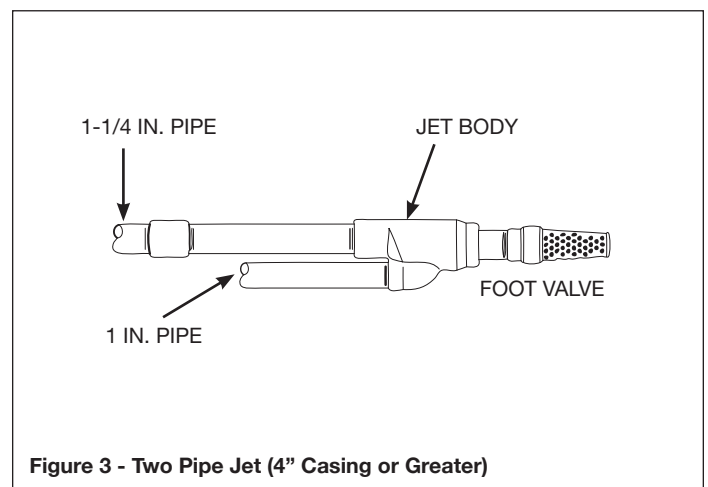

## INSTALLATION (CONTINUED)

- Slope the horizontal pipes upward toward the pump to prevent trapping air. If horizontal distance exceeds 25 feet, see Chart 1 for recommended pipe sizes.

### DRILLED WELL (2 IN.) WITH SINGLE PIPE PACKER (FIGURES 16 AND 4)

**NOTE:** Single pipe packer jets rely on the space between single pipe and inside of well casing for return water to operate jet. Two inch installations must use 1-1/4 in. galvanized steel pipe with special turned couplings (1-13/16 in. O.D.) to avoid restricting flow of return water back to jet.

- Assemble the foot valve and packer to the jet body.
- Lubricate the rubber cups with petroleum jelly.
- Attach the first section of pipe and lower jet into well.
- Add pipe until the jet is positioned 5 - 15 feet below the lowest anticipated water level. The jet should never be closer than 5 feet from the bottom of the well or sand and sediment may be drawn into the system.
- With the jet in position, fill the pipes with water to make sure the rubber cups are sealed against inside of the well casing. It may be necessary to move the jet up and down to seat the cups.
- Install the casing adapter and the horizontal pipes.
- Slope both pipes upward toward the pump to eliminate trapping air. If the horizontal distance exceeds 25 feet, see Chart 1 below, for the recommended pipe sizes.

CHART 1 - PIPE SIZING

Pump Model	Pump Opening	Horizontal Distance (Feet)	
		0-25	26-100
Deep Well	Inlet: Suction	1-1/4 in.	1-1/2 in.
	Inlet: Drive	1 in.	1-1/4 in.
	Outlet	3/4 in.	1 in.

### DEEP WELL PUMP WITH HORIZONTAL AND VERTICAL STORAGE TANK (FIGURES 5 AND 6)

- Install the air volume control on the tank as shown.

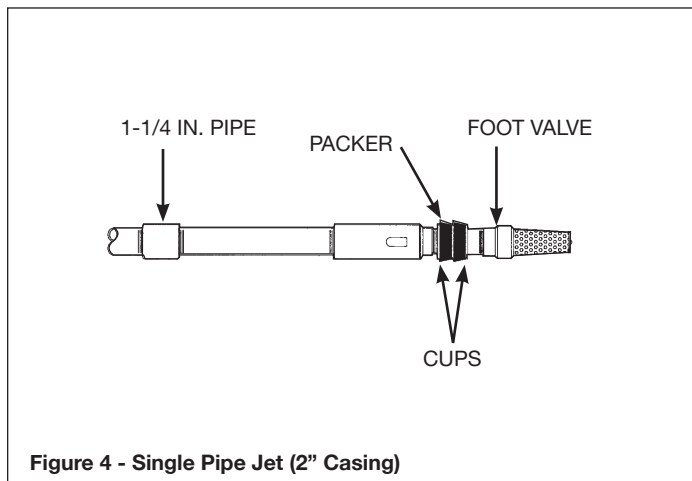

- Connect the copper tube from the air volume control to the 1/8 in. NPT opening directly above the 1-1/4 in. opening on the front of the pump.
- Install a valve and isolating hose between the system and the house plumbing to aid in pump removal for servicing and for reducing noise transmitted through the house piping.
- Provide a faucet at the lowest point in the system to drain for service or storage.

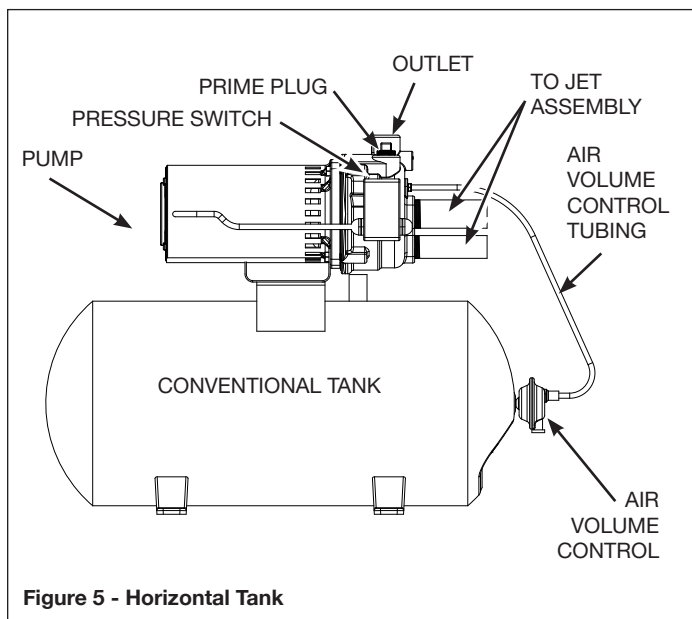

## INSTALLATION (CONTINUED)

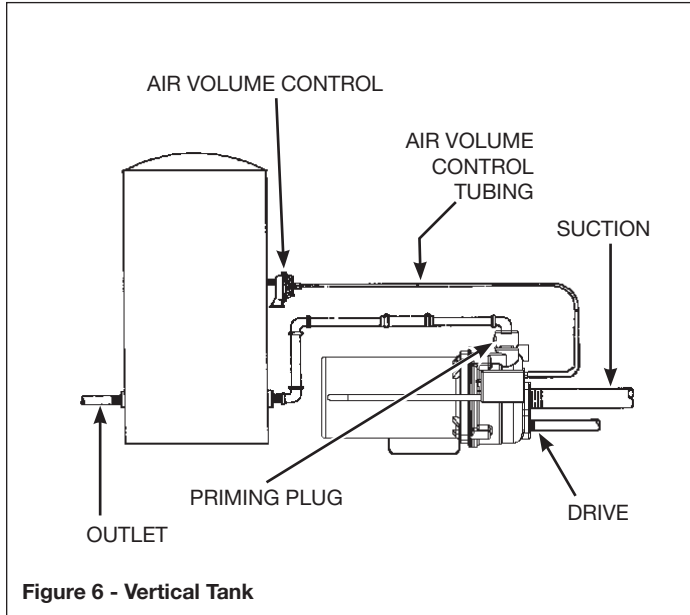

### DEEP WELL PUMP WITH PRE-CHARGED STORAGE TANK (FIGURE 7)

1. Check tank pre-charge using a tire pressure gauge. Set air pressure in tank to 28 psi which is 2 psi below pressure switch cut-in level. An air valve is located on the side and will accept a standard fitting from a bicycle pump or air line.
2. Check the pressure with the power off, faucets open and no water flowing (zero water pressure).
3. Install a valve and isolator hose between the system and the house plumbing to aid in pump removal for servicing and for reducing noise transmitted to the house through the piping.
4. Provide a faucet at the lowest point in the system to drain for service or storage.

### CONVERTING THE DEEP WELL PUMP TO SHALLOW WELL OPERATION (FIGURE 8)

For shallow wells (25 feet or less), a bolt-on shallow well jet is available as an accessory for deep well pumps. The jet attaches to the front of the pump with the two bolts provided and converts the deep well pump into a shallow well pump. The shallow well jet has a 1 in. NPT inlet and a 1/8 in. NPT opening for an air volume control. For optimum performance, an inline check valve on the inlet side of the shallow well jet is recommended.

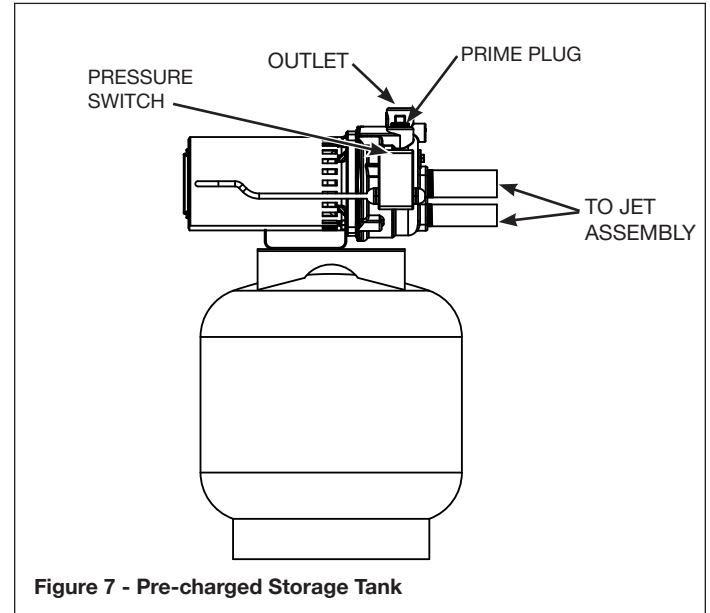



**ELECTRICAL**

**▲ WARNING** Risk of electrical shock. This pump is designed for indoor installation only, unless housed and protected from the elements.

**▲ AVERTISSEMENT** Installer un écran autour du tuyau d'entrée pour éviter de piéger des nageurs, des animaux et des débris.

Select the proper size wire and fuse. Time delay fuses are recommended over standard fuses for motor circuit protection. All pump motors have built-in automatic overload protection that will prevent damage to the motor due to overheating. If wire run is a short distance, a cord/plug assembly may be used as long as it meets the minimum wire gage size called out in Chart 2.

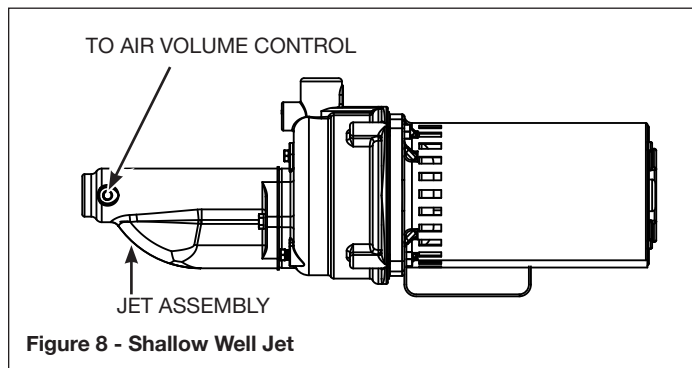

**▲ WARNING** Do not connect to electric power supply until unit is permanently grounded. Connect ground wire to approved ground then connect terminal provided.

**▲ AVERTISSEMENT** Ne pas connecter à l'alimentation électrique tant que l'unité n'est pas mise à la terre en permanence. Brancher le fil de mise à la terre à la masse approuvée puis raccorder la borne fournie.

A metal underground water pipe or well casing at least 10 feet long makes the best ground electrode. If plastic pipe or insulated fittings are used, run a wire directly to the metal well casing or use a ground electrode furnished by the power company.

There is only one proper ground terminal on the unit. The terminal is located under the pressure switch cover, is painted green and is identified as GRD. The ground connection must be made at this terminal (Figure 9).

The ground conductor must not be smaller than the circuit conductors supplying the motor.

The voltage of power supply must match the voltage of the pump. The unit has dual voltage motors preset at the factory to 115 volts. The motors can be converted to 230 volts by changing the voltage selector to the desired voltage (Figure 10). Disconnect power, use needle nose pliers to pull the selector out approximately 1/4 in., point too, and then reinsert in correct position.

**▲ WARNING** Disconnect power and release all pressure from the system before attempting to install, service, relocate or perform any maintenance.

**▲ AVERTISSEMENT** Débrancher de la source d'alimentation puis dissiper toute la pression du système avant d'essayer d'installer, de réparer, de déplacer ou de procéder à l'entretien.

**OPERATION**

**PRIMING THE SHALLOW WELL PUMP**

**▲ WARNING** To prevent damage to the pump, do not start motor until pump has been filled with water.

**▲ AVERTISSEMENT** Pour éviter d'endommager la pompe, ne pas démarrer le moteur tant que la pompe n'a pas été remplie d'eau.

**NOTICE** When the deep well pump is used with the bolt-on shallow well jet, be sure the control valve slot (Figure 11) is in the vertical (open) position at all times.

1. Remove prime plug.
2. Fill pump and piping completely full of water.
3. Replace the prime plug.

**CHART 2 - RECOMMENDED FUSE AND WIRING DATA - 60 HZ MOTORS**

HP	Volt	Dual Element Fuse 250V	Distance in Feet From Meter to Motor		
			0 to 50	51 to 100	101 to 200
1/2	115	20	14	12	10
	230	10	14	14	14
3/4	115	20	14	12	8
	230	10	14	14	14
1	115	20	14	12	8
	230	10	14	14	14

\* above is the suggested size only. Check with local or state code for proper sizing.

# Operating Instructions and Parts Manual

## OPERATION (CONTINUED)

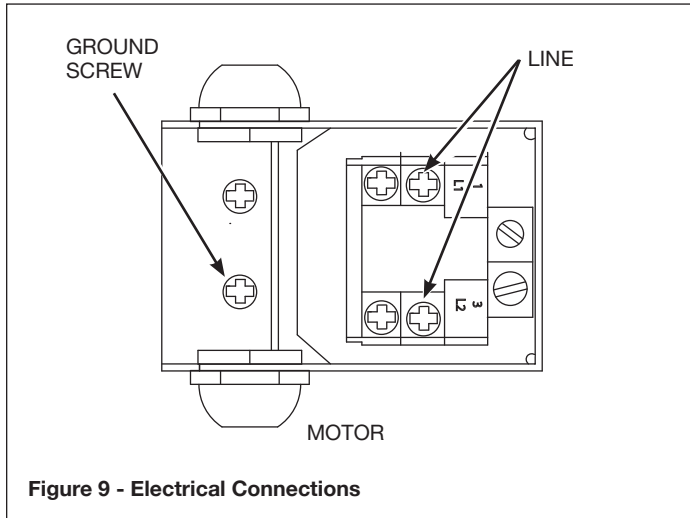

Figure 9 - Electrical Connections

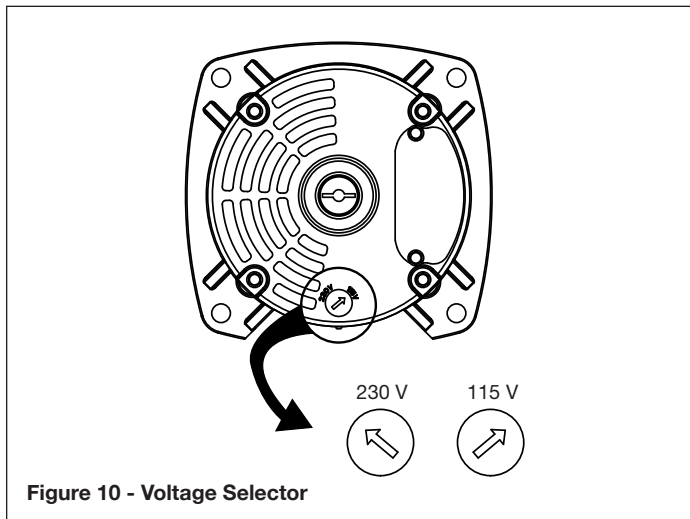

Figure 10 - Voltage Selector

4. Open a faucet to vent the system.
5. Start the motor. Water will pump in a few minutes. If pump fails to prime in 5 minutes, stop motor and refill pump with water. Priming time is proportional to the amount of air in inlet pipe. Do not allow pump to get hot.
6. Let the system operate for several minutes to flush all pipes.
7. Close faucet and allow pump to build pressure in tank. When the pressure reaches the cut-out setting, the motor will stop.

The system is now in operation and will automatically cycle on demand.

## PRIMING THE DEEP WELL PUMP

**⚠ WARNING** To prevent damage to the pump, do not start motor until pump has been filled with water.

**⚠ AVERTISSEMENT** Pour éviter d'endommager la pompe, ne pas démarrer le moteur tant que la pompe n'a pas été remplie d'eau.

1. Remove prime plug.
2. Fill pump and piping completely full of water.
3. Replace the prime plug.
4. Close the control valve (Figure 11) and open a nearby faucet.
5. Start the motor. The pressure inside the pump body will build almost immediately as the pump, jet and piping become completely filled with water.
6. Slowly open the control valve. Water will begin to flow. Continue to open the control valve until maximum flow is achieved. Opening the valve too far will cause the water to stop flowing.

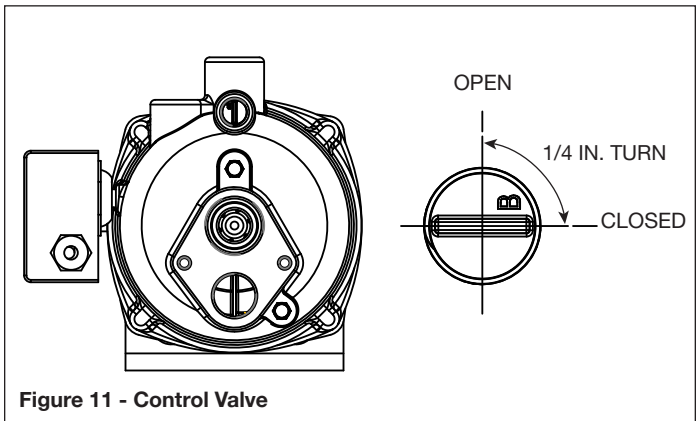

Figure 11 - Control Valve

7. Adjust the valve until there is a steady flow of water. The valve should be opened as much as possible without losing pressure.
8. Let the system operate for several minutes to flush all piping.
9. Close the faucets and allow the pump to build pressure in the tank. When the pressure reaches the cut-out setting, the motor will stop.

The system is now in operation and will automatically cycle upon demand.

## MAINTENANCE

**▲ WARNING** *Disconnect power and release all pressure from the system before attempting to install, service, relocate or perform any maintenance. Lock the power disconnect in the open (off) position. Tag out the power disconnect to prevent unexpected application of power.*

**▲ AVERTISSEMENT** *Débrancher de la source d'alimentation puis dissiper toute la pression du système avant d'essayer d'installer, de réparer, de déplacer ou de procéder à l'entretien. Verrouiller le sectionneur de courant en position ouverte (OFF). Étiqueter le sectionneur de courant pour éviter toute mise sous tension imprévue.*

**▲ CAUTION** *Protect the pump from freezing during winter conditions.*

**▲ MISE EN GARDE** *Protéger la pompe du gel pendant l'hiver.*

### DRAINING THE PUMP

Drain openings are provided on all models. To drain the pump:

1. Remove drain plug and prime plug to vent the system.
2. Drain all piping to a point below the freeze line.

### DRAINING THE TANK

Conventional tanks can be drained by opening an outlet at the lowest point in the system. Remove plug or the air volume control to vent the tank.

Pre-charged tanks force virtually all the water from the tank when system pressure is released. No draining is necessary.

### RESTARTING PUMP

If the pump has been serviced, drained or has not been used for some time, be sure there is water in the pump housing (volute) and the piping to the well. There must be water in the pump housing (volute) at all times when the pump is running to avoid internal damage of seal members (See Priming the Shallow Well or Priming the Deep Well Sections).

### WATERLOGGED TANKS: CONVENTIONAL

When a tank system has an inadequate ratio of air and water, the pump will start and stop often and erratically.

1. Disconnect the power to the pump.
2. Open the lowest faucet in the system to release all pressurized water in the system.
3. Prime the pump (See Priming the Shallow Well or Priming the Deep Well Sections).
4. Reconnect the power to the pump.

**NOTE:** As the pump refills the tank with water, the air volume control supplies the tank with the correct air to water ratio for the system to operate. If the air volume control is good, the pump will shut off at the desired cut-off and will be adjusted correctly.

### WATERLOGGED TANKS: PRE-CHARGED

If a pre-charged tank becomes waterlogged, the bladder is normally leaking or broken.

1. Test the tank by depressing the air valve. The air valve will expel water if the bladder is broken.
2. Replace the tank.

**NOTE:** Once an internal bladder is leaking or broken, the bladder cannot be repaired. The tank must be replaced.

### PRE-CHARGED TANK

Some air is lost through the internal bladder in any tank. To prevent tank failure, check the tank pre-charge on a yearly basis.

1. Disconnect power to the pump
2. Open a faucet nearest the tank and allow all water to drain from the tank.
3. Measure the tank pre-charge at the valve stem using a tire gauge.
4. If necessary, adjust the pre-charge with an air pump 28 - 30 psi on 1/2, 3/4 and 1 HP pumps.

### LUBRICATION

The bearing used in the pumps are lifetime lubricated at the factory and require no additional lubrication.

### CWS REPAIR KIT

1. Disconnect power from the pump.
2. Open faucet nearest the tank and allow all of the water to drain from the tank and pump.
3. Remove 4 cap screws holding pump housing, do not disconnect pressure switch (Figure 12).
4. Remove pump housing from pump assembly, move it out of the way.
5. Using a 5/16" socket or flat blade screw drive remove the 2 screws from the diffuser on the pump assembly.
6. Remove the diffuser.
7. Remove the black plastic cap from the back of the motor, exposing the motor shaft end.
8. Using a large flat bladed screw driver hold the motor shaft while unscrewing the impeller.
9. Remove the seal plate. Pay attention to how the original shaft seal is installed before disassembly.

## Operating Instructions and Parts Manual

10. Remove the shaft seal from the impeller, make sure the stainless steel sleeve comes off the impeller, all you should see on the back of the impeller is the brass colored threaded insert (Figure 13).
11. Remove the ceramic seat and rubber boot part of the seal from the cast iron seal plate (Figure 13).
12. Remove the square cut gasket from the seal plate.
13. Reassemble the pump with new parts in reverse order.
14. Wipe down the seal plate to remove any debris or loose rust.
15. Push the ceramic seat of the shaft seal into the seal plate using the cardboard ring provided to keep the ceramic face clean. You can use a little water or dish soap to lubricate the seal pocket to make assembly easier.
16. Slide the square cut gasket over the flange on the seal plate, make sure not to let the gasket twist.
17. Carefully slip the seal plate over the shaft so as not to disturb seal position in the seal plate. The seal plate must be orientated during assembly so the two holes are on a horizontal line across the motor shaft (Figure 14).
18. Push the bellows side of the shaft seal over the impeller hub, you can use a little water or dish soap to lubricate the impeller hub to make assembly easier (Figure 15). Make sure after assembly the back carbon and white ceramic surfaces are in contact.
19. Holding the motor shaft with a flat blade screw driver thread the impeller onto the motor shaft, hand tighten. Lubricate the nose of the impeller with potable water safe lubricant.
20. Replace the plastic cap over the motor shaft end.
21. Reassemble the diffuser, make sure the arrow indicating the top is pointed toward the top of the pump, torque the two screws to  $30 \pm 10$  inch pounds.

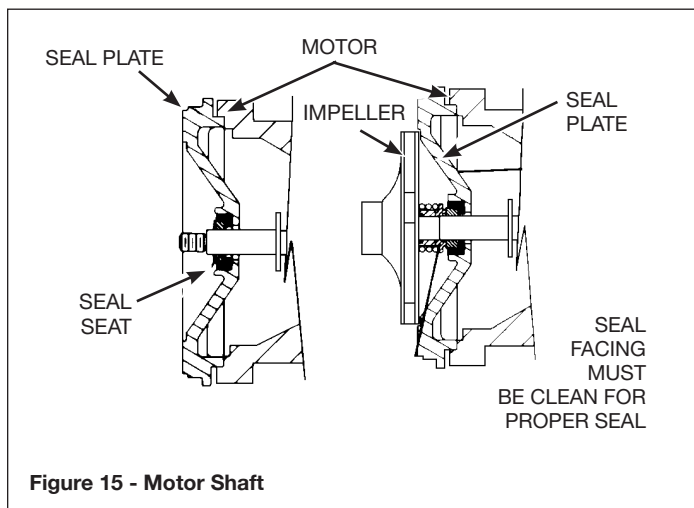

22. Using the (4) cap screws reattach the pump housing and base to the pump body. Torque the screws to  $140 \pm 40$  inch pounds.
23. Reattach the plumbing connections, reconnect the power and prime the pump (See section on priming the pump). After reassembling the pump check for leaks. If a leak is detected, repair before using the pump.

## NOTES

WATER SUPPLIES

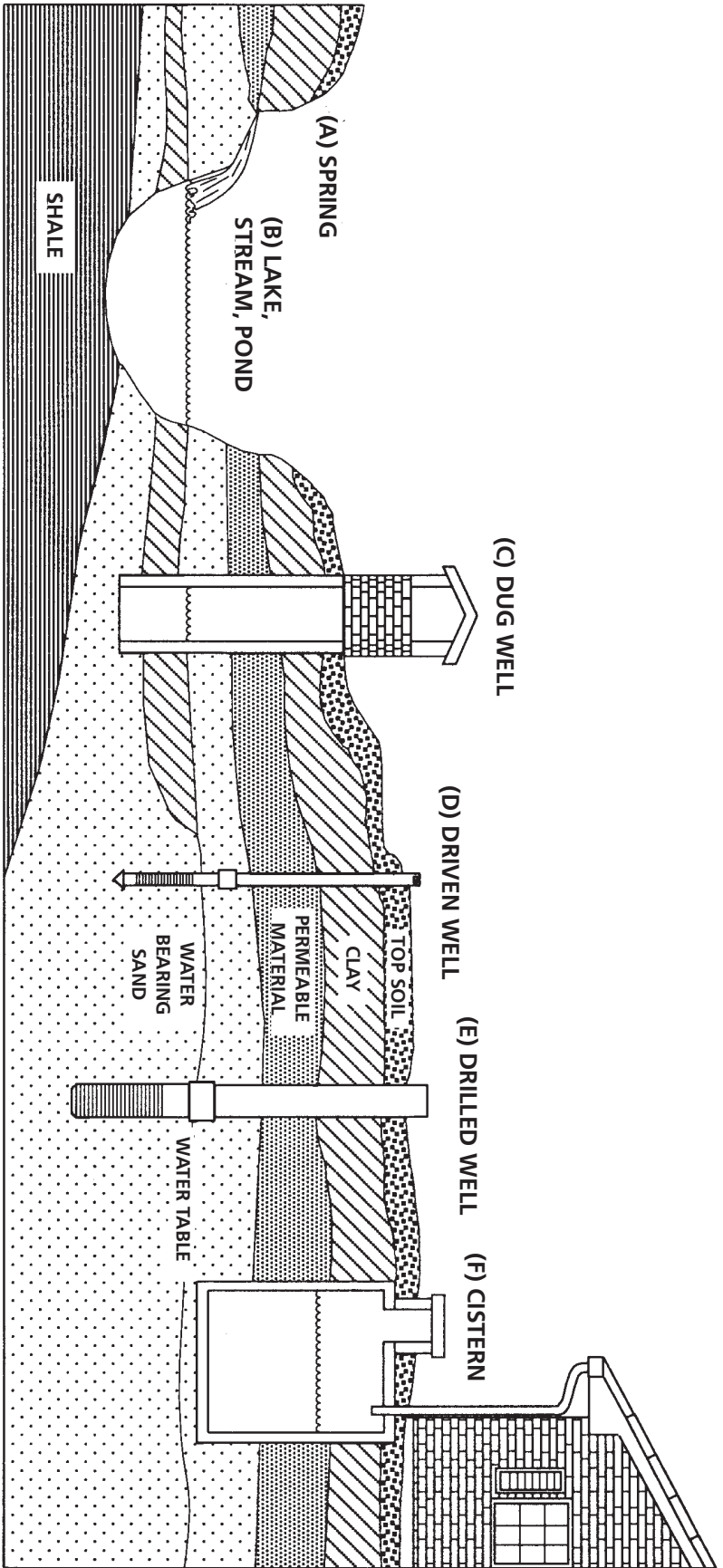

**(A) SPRING:**  
 A spring that emerges from the ground. Occurs when water in permeable materials is trapped between impermeable material as rock or clay.

**(B) LAKE, STREAM or POND:**  
 Surface water, unless treated, is usually not safe for human consumption. It may be used for purposes such as washing or irrigation.

**(C) DUG WELL:**  
 A hole is excavated several feet in diameter to a fairly shallow depth. It is then lined with brick, stone or concrete to prevent cave-in.

**(D) DRIVEN WELL:**  
 Pipe with a pointed screen is driven into the ground below the water table. The depth is usually less than 50 feet. Available diameters are 1" through 2".

**(E) DRILLED WELL:**  
 A hole bored into the earth with machinery and lined with pipe. Depths range from a few feet to over 1000 feet. Common well diameters are 2", 3", 4" and 6" for domestic water wells.

**(F) CISTERN:**  
 An underground tank built to collect rain water from rooftops. The water is not fit for human consumption.

Figure 16 - Water Supplies

# Operating Instructions and Parts Manual

## TROUBLE SHOOTING CHART

Symptom	Possible Cause(s)	Corrective Action
Pump will not run	<ol style="list-style-type: none"> <li>1. Power off</li> <li>2. Blown fuse or tripped breaker</li> <li>3. Faulty pressure switch</li> <li>4. Motor overload tripped</li> <li>5. Low supply voltage</li> </ol>	<ol style="list-style-type: none"> <li>1. Turn power on or call power company</li> <li>2. Replace fuse or reset circuit breaker</li> <li>3. Replace 30/50 pressure switch</li> <li>4. Let cool. Overload will automatically reset</li> <li>5. Contact an electrician</li> </ol>
Motor hums but will not run	<ol style="list-style-type: none"> <li>1. Line voltage does not match selector switch</li> <li>2. Wiring too small</li> <li>3. Damage or misalignment causing rotating parts to bind</li> <li>4. Low supply voltage</li> </ol>	<ol style="list-style-type: none"> <li>1. Check voltage</li> <li>2. Rewire</li> <li>3. Replace or take to service shop for repair</li> <li>4. Contact an electrician</li> </ol>
Overload trips	<ol style="list-style-type: none"> <li>1. Low supply voltage</li> <li>2. Damage or misalignment causing rotating parts to bind</li> <li>3. High surrounding temperature</li> <li>4. Rapid cycling</li> <li>5. Inadequate wiring</li> </ol>	<ol style="list-style-type: none"> <li>1. Contact an electrician</li> <li>2. Take to motor repair shop or locate and repair mechanical binding</li> <li>3. Provide a shaded, well-ventilated area for pump</li> <li>4. See "Pump starts and stops too often" section</li> <li>5. Rewire</li> </ol>
Pump runs but delivers little or no water	<ol style="list-style-type: none"> <li>1. Water level below pump intake</li> <li>2. Control valve open too far (deep well)</li> <li>3. Discharge not vented while priming</li> <li>4. Leaking in piping on well side of pump</li> <li>5. Well screen or inlet strainer clogged</li> <li>6. Clogged nozzle (deep well)</li> <li>7. Air volume control diaphragm ruptured</li> <li>8. Foot valve may be clogged or stuck closed</li> <li>9. Pump not fully primed</li> <li>10. Control valve completely closed (deep well)</li> <li>11. Water level below maximum lift specification</li> <li>12. Undersized piping</li> <li>13. Gaseous well</li> <li>14. Distorted venturi</li> <li>15. Incorrect jet assembly for application</li> <li>16. Undersized pump</li> <li>17. Pump cavitates, (sounds like pumping gravel)</li> <li>18. Low supply voltage</li> </ol>	<ol style="list-style-type: none"> <li>1. Lower suction pipe further into well</li> <li>2. Adjust control valve or repeat priming procedure.</li> <li>3. Open faucet, repeat priming procedure</li> <li>4. Repair piping as needed</li> <li>5. Clean or replace as necessary</li> <li>6. Pull jet and clear obstruction</li> <li>7. Replace air volume control (See Page 7)</li> <li>8. Clean or replace as needed</li> <li>9. Continue priming, pausing every 5 minutes to cool pump body. Refill pump as needed</li> <li>10. Adjust control valve per deep well priming procedure (see page 8)</li> <li>11. Select applicable pump and/or jet assembly</li> <li>12. Replace as needed</li> <li>13. Install baffle on pump intake to prevent gas from entering system</li> <li>14. Inspect and replace</li> <li>15. Purchase a jet assembly matched to your system when replacing another brand pump</li> <li>16. Increase horsepower of pump</li> <li>17. Increase suction plumbing diameter or decrease pipe friction</li> <li>18. Contact an electrician</li> </ol>
<p><b>Note:</b> Check to make sure pump is properly primed before looking for other causes. Unscrew priming plug and see if water is in priming hole.</p>		
Pump starts and stops too often	<ol style="list-style-type: none"> <li>1. Water logged tank (conventional tank)</li> <li>2. Air volume control tubing kinked or clogged</li> <li>3. Air volume control tubing connected to wrong opening on pump</li> <li>4. Incorrect tank pre-charge (pre-charged tank)</li> <li>5. Ruptured diaphragm/bladder (pre-charged tank)</li> <li>6. Leak in house piping</li> <li>7. Foot valve or check valve stuck open</li> <li>8. Motor overload tripping</li> <li>9. Faulty pressure switch</li> </ol>	<ol style="list-style-type: none"> <li>1. See waterlogged conventional tank on page 11</li> <li>2. Clean or replace as needed</li> <li>3. Move to correct pump opening</li> <li>4. Add or release air as needed</li> <li>5. Replace tank</li> <li>6. Locate and repair leak</li> <li>7. Remove and replace</li> <li>8. See overload trips section</li> <li>9. Replace 30/50 pressure switch</li> </ol>

**For Replacement Parts or Customer Support, Call 1-800-237-0987**

**Please provide following information:**

- Model number
- Serial number (if any)
- Part description and number as shown in parts list

**Address parts correspondence to:**

Wayne Water Systems  
 101 Production Drive  
 Harrison, OH 45030 U.S.A.

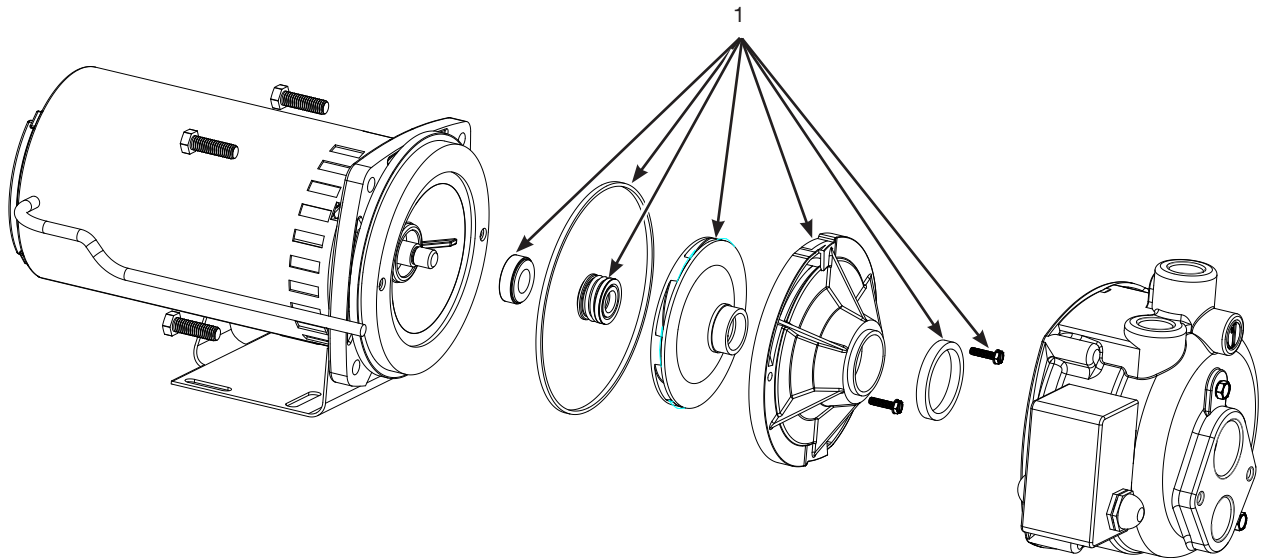

**REPLACEMENT PARTS**

Ref. No.	Description	Models	Qty.
CWS50, CWS75, CWS100			
1	(2) Square-Ring Gaskets, Impeller, Jet Pump Diffuser, and Shaft Seal Assembly	64046-WYN1 (CWS50) 64047-WYN1 (CWS75) 64047-WYN1 (CWS100)	1
2	30/50 Pressure Switch Kit	64031-WYN1 (ALL MODELS)	1

**JET ASSEMBLIES**

Description	Vertical Distance (ft.)	Part No.	Qty.
Jet Assemblies	N/A	56326-WYN1 (CWS50, Shallow) 56316-WYN1 (CWS75, CWS100, Shallow)	1
2 Inch Casing Jet Assemblies	30' - 80'	55462-WYN1 (ALL MODELS)	1
4 Inch Casing Jet Assemblies	30' - 100'	55465-WYN1 (ALL MODELS)	1

## **LIMITED WARRANTY**

For three years for CWS Series models from the date of purchase, from an authorized dealer, Wayne Water Systems will repair or replace, at its option for the original purchaser, any part or parts of its Well Pumps or Water Pumps ("Product") found upon examination by Wayne Water Systems to be defective in materials or workmanship. Please call Wayne Water Systems (800-237-0987) for warranty instructions. Be prepared to provide the model number and the serial number when exercising this warranty. All transportation charges on Products or parts submitted for repair or replacement must be paid by purchaser.

This Limited Warranty does not cover Products which have been damaged as a result of accident, abuse, misuse, neglect, improper installation, improper maintenance, or failure to operate in accordance with Wayne Water Systems' written instructions.

**THIS WARRANTY IS IN LIEU OF ANY AND ALL OTHER WARRANTIES, OBLIGATIONS OR AGREEMENTS, EXPRESSED OR IMPLIED, INCLUDING ANY IMPLIED WARRANTY OF MERCHANTABILITY OR FITNESS FOR ANY PARTICULAR PURPOSE, AND ANY RIGHTS OR REMEDIES AGAINST ANY PERSON OR ENTITY UNDER THE UNIFORM COMMERCIAL CODE OR OTHERWISE WITH RESPECT TO THE SALE OF THE PRODUCT. THE REMEDIES AND OBLIGATIONS STATED IN THIS WARRANTY ARE THE SOLE AND EXCLUSIVE REMEDIES OF AND OBLIGATIONS TO THE OWNER FOR ANY AND ALL MATTERS ARISING WITH RESPECT TO OR IN ANY WAY CONNECTED WITH THE PRODUCT, REGARDLESS OF THE SOURCE OR PROVIDER OF SUCH GOODS. IN NO EVENT, WHETHER AS A RESULT OF BREACH OF CONTRACT, WARRANTY TORT (INCLUDING NEGLIGENCE) OR OTHERWISE, SHALL WAYNE WATER SYSTEMS OR ANY AFFILIATE BE LIABLE FOR ANY SPECIAL, INCIDENTAL OR CONSEQUENTIAL DAMAGES.**

You **MUST** retain your purchase receipt along with this form. In the event you need to exercise a warranty claim, you **MUST** send a **copy** of the purchase receipt along with the material or correspondence. Please call Wayne Water Systems (800-237-0987) for return authorization and instructions.

**DO NOT MAIL THIS FORM TO Wayne Water Systems.** Use this form only to maintain your records.

MODEL NO. \_\_\_\_\_ SERIAL NO. \_\_\_\_\_ INSTALLATION DATE \_\_\_\_\_

**ATTACH YOUR RECEIPT HERE**