

OWNER'S MANUAL

VOLT EDGE

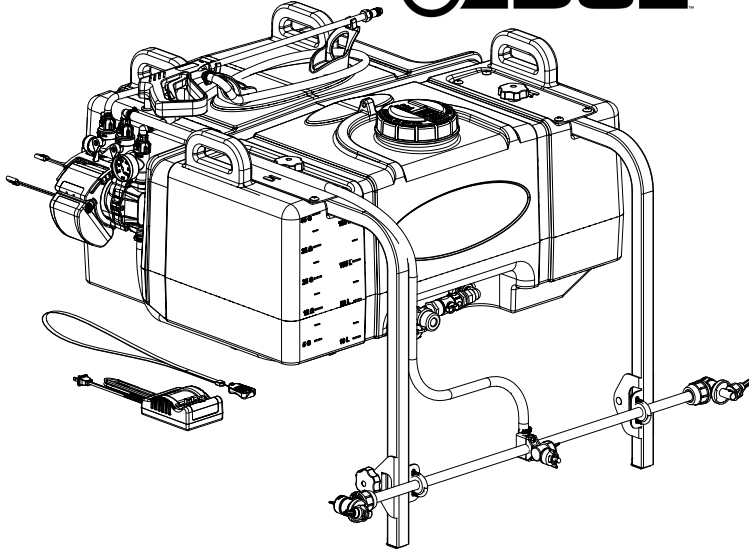

General Information

Thank you for purchasing this product. The purpose of this manual is to assist you in operating and maintaining your UTV sprayer.



WARNING: To reduce the risk of injury, the user must read and understand the operator's manual before using this product.



WARNING: Cancer and Reproductive Harm
www.P65Warnings.ca.gov

BEFORE RETURNING THIS PRODUCT
FOR ANY REASON, PLEASE CALL

1-800-831-0027

MONDAY-FRIDAY, 8:00 AM TO 5:00 PM CST

If you should have a question or experience a problem with your Fimco Industries Product: Visit our website @ www.fimcoindustries.com or call the Toll free number above. Our technical support representatives will be happy to help you. In most cases a customer service rep. can resolve the problem over the phone.

To obtain prompt, efficient service, always remember to give the following information...

- Correct Part Description and/or part number
- Model number and Serial Number

Part descriptions and numbers can be obtained from the illustrated parts list section(s) of this manual.

Retain a copy of your receipt for your unit, as it will be required to validate any warranty service.

Warranted against manufacturer or workmanship defects from date of purchase with copy of receipt:

Homeowner Usage: Sprayer-One Year and Pump-Two Years.

Commercial Usage: Sprayer and Pump-90 Days.



**Model: 20V-UTV-45-BL
(5303067)**

(45 Gallon Lawn & Garden UTV Sprayer w/Boomless Boom & Volt Edge System)

Technical Specifications

- 45 Gal. Corrosion-Resistant Polyethylene Tank
- Deluxe Pistol-Grip Handgun w/25 Ft. Handgun Hose
- Max. Throw: 28' Vertical, 40' Horizontal
- 30' Spray Coverage with Boom
- Adjustable Boom Height
- 12 Volt, 4.5 GPM - 60 PSI Diaphragm Pump
- Volt Edge 20Vmax Lithium Ion System
1 Tank, 20 Minutes Spraying & 45 Gallons per Charge
- Multi-Lid to accurately measure and pour chemicals

Caution: When fully filled with water, this sprayer will weigh 505 lbs.. Consult the owner's manual for your vehicle to verify that you are within it's load carrying capacity.

Secure unit in your UTV, using tie-down straps (NOT INCLUDED)

Assembly Instructions

The sprayer is partially assembled at the factory. Follow the assembly instructions on pages 2 and 3..

Read the operating instructions for both the sprayer and the Volt Edge system before using your sprayer. Then run the sprayer using only water for testing. When everything tests all right, add the desired chemical mixture and water combination and start the spraying operation.

IMPORTANT REMINDER

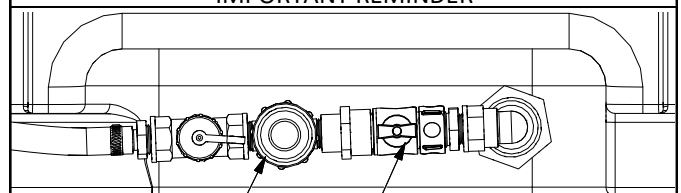

Filter
On/Off Valve

This sprayer comes with an On/Off valve located on your intake line. You must make sure the valve is in the "open" position before using your sprayer.



www.fimcoindustries.com

1000 FIMCO Lane, P.O. Box 1700, North Sioux City, SD 57049
Toll Free Phone: 800-831-0027 : Toll Free Fax: 800-494-0440

[5195246

(09/19)]

End Nozzle Assembly Procedure

For Boomless "Wet" Boom

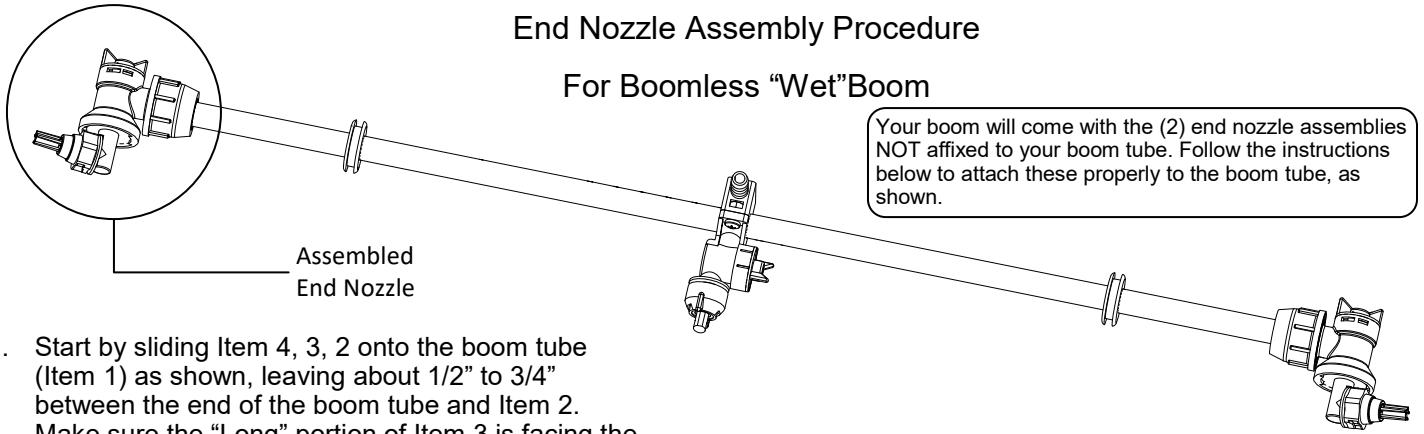

Your boom will come with the (2) end nozzle assemblies NOT affixed to your boom tube. Follow the instructions below to attach these properly to the boom tube, as shown.

1. Start by sliding Item 4, 3, 2 onto the boom tube (Item 1) as shown, leaving about 1/2" to 3/4" between the end of the boom tube and Item 2. Make sure the "Long" portion of Item 3 is facing the nozzle end.
2. Slide the (complete) end nozzle assembly onto the stainless steel boom tube, with a somewhat "twisting" motion, so that the end face of the boom tube "butts" up against the surface face inside the nozzle body.
3. Now push the "compression olive" (Item 3) against o-ring (Item 2) and slide (both) into the nozzle body opening firmly.
4. Firmly tighten flynut (Item 4) onto threads of nozzle body.
5. Repeat for other side.

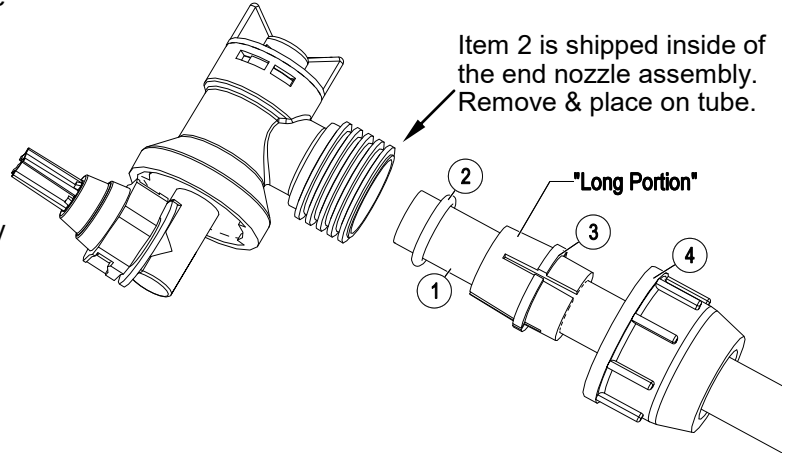

NOTE: If water is shooting back on the boom tube, item 2 is not in the correct placement.

End Nozzle Information (5275122)

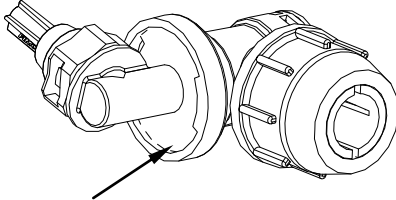

This nozzle mounting stem
Has a ratcheting motion.

** Each "click" of the ratcheting motion is approx. 15° **

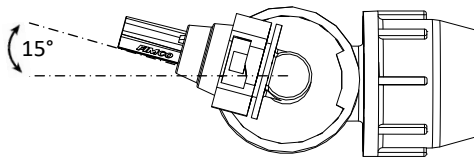

For proper/optimal spray coverage,
The nozzle must be at a 15° angle

The 15° angle shown will prevent the outer
Nozzles from overlapping with the center nozzle.

"On/Off" Valve Positions

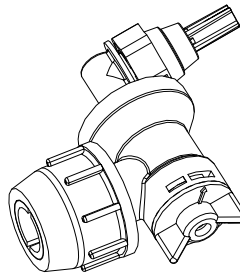

Valve "Open"

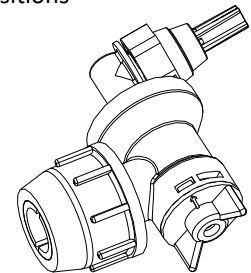

Valve "Closed"

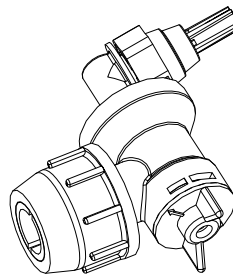

Service Position

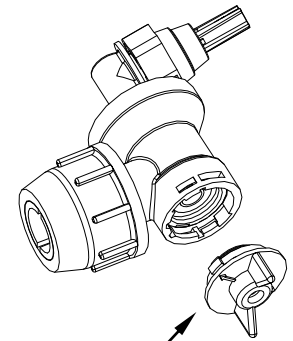

On/Off Valve Knob

Eliminate line pressure, then pull out
to check diaphragm condition.

Note: The check valve & diaphragm can fall out during transport, if the knob is not turned to the "ON" or "OFF" position.

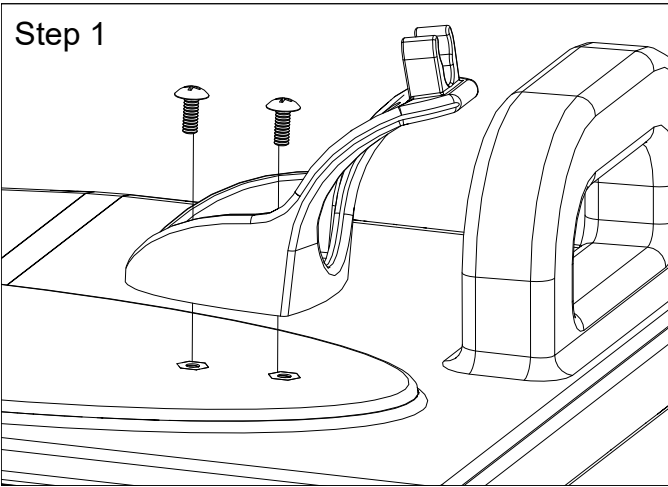

Step 1
Attach the (2) Hose Wraps to the top of the tank with (4) Phillips Head Screws

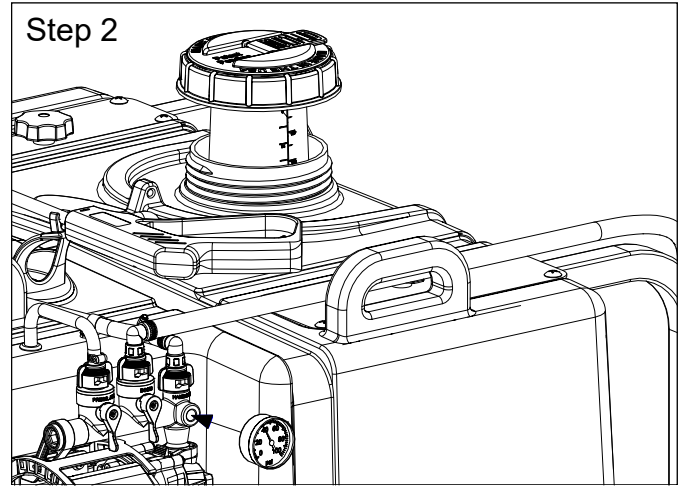

Step 2
Thread Pressure Gauge into open port on manifold., as shown.

Thread Multi-Lid on to tank.

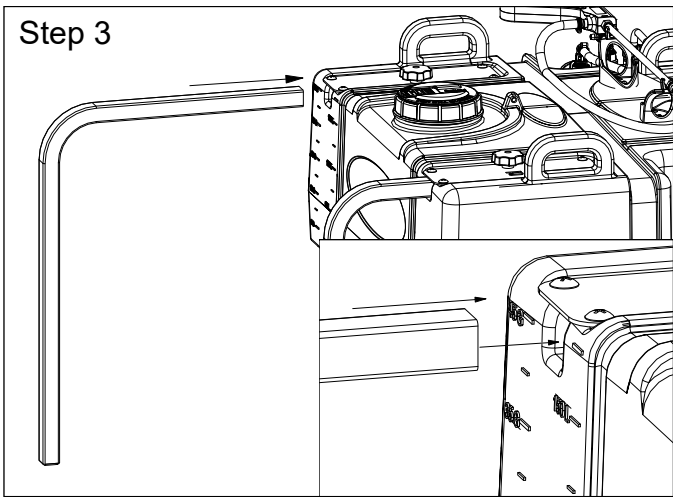

Step 3
With the unit in a UTV Box, slide the boom mount tubes in to the tank mounts and tighten the lobe knob.

* Secure tank using tie-down straps (NOT INCLUDED)

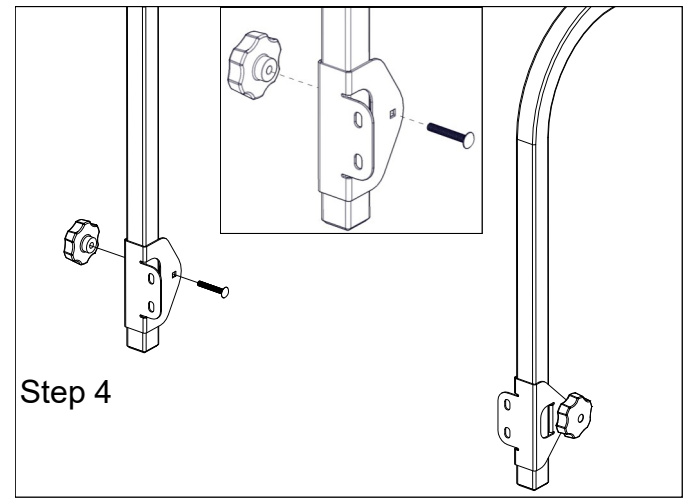

Step 4

Slide the boom clamps up the boom mount tubes and install the 1/4" carriage bolt and Lobe Knob., make sure the boom clamps are installed with the square carriage bolt holes or two boom mount holes to the inside and the lobe knob to the outside.

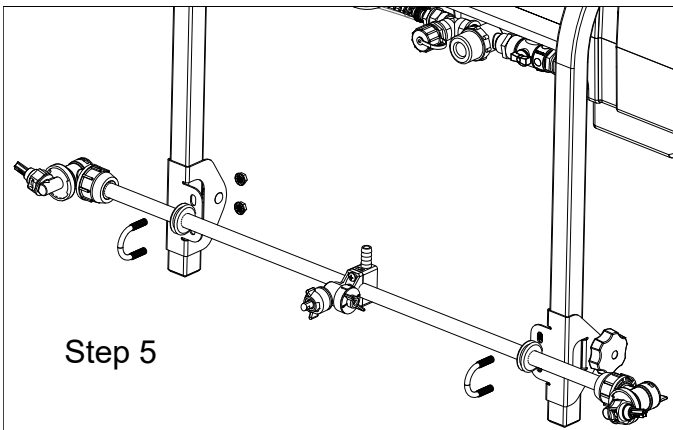

Step 5

Using the round U-bolts and nuts, attach the boom to the boom clamps.

Finally attach boom hose. Slip (2) 1/2" hose clamps onto hose. Attach one end of hose to the boom and the other end to the manifold. The boom hose can be cut to length if needed.

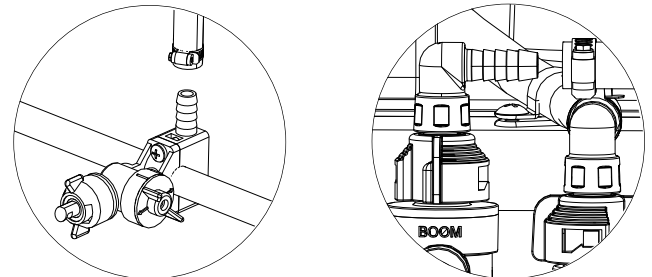

Once fully assembled, to remove the sprayer from a UTV Box, disconnect the boom supply hose from the manifold, using the quick connect fitting. Then loosen the two lobe knobs on the tank mounts and slide the boom out and set aside. Then the tank can be removed and set on the ground without damaging the tank or boom. The handles can be used to lift the empty tank in and out of the box. Tie down straps can be installed through the handles to secure the tank.

IMPORTANT: Remove tank lid and be sure the tank is clean and free of any foreign material. Rinse tank out of any tank residue before filling with water to test.

Testing the Sprayer

NOTE:

CHECK and TEST the completed sprayer with plain water. This will enable you to check the sprayer for leaks without the possibility of losing any expensive chemicals.

Fill the tank about 1/2 full with plain water and drive to the starting place for spraying.

When you are ready to spray, turn the boom valve to the "on" position (Detail A). This will start solution spraying from the tips of the boom. The pressure will decrease slightly when the boom is spraying.

Adjust the pressure by turning the "ON/OFF" valve lever on the bypass line valve (Detail B). Make sure your pattern is sufficient. You may down-pressure the system by 'bypassing' solution back into the tank. This is achieved by opening the bypass valve. Regulating pressure is done in this manner.

Read the operating instructions and initially begin spraying by closing the 'Pressure Adjust' valve and opening the boom line valve (Detail A). This will enable the air in the line to be eliminated (purged) through all the tips, while building pressure. When everything tests all right (no leaks and good pressure), add the desired chemicals to the mixture and water combination and start your spraying operation. Adjust the pressure and spray as you did in the testing procedure.

Conditions of weather and terrain must be considered when setting the sprayer. Do not spray on windy days. Protective clothing must be worn in some cases

Be sure to read the chemical label(s) before application!

Operation

The pumping system draws solution from the tank, through the strainer and to the pump. The pump forces the solution under pressure to the handgun or boom nozzles.

NOTE: Read and follow the Volt Edge instructions, later in this manual, for charging and operation of the 20Vmax Lithium Ion System.

Fill the tank part way with water and then add the desired amount of chemical to be sprayed. Finish filling tank to proper level. Turn the pump on and by depressing the "-" side of the rocker switch. The pump is equipped with a pressure switch that is pre-set at the factory to shut the pump off when all discharges are closed.

The pump will turn back on when one of the following actions occurs:

- ◆ Handgun lever is squeezed to spray the handgun.
- ◆ Boom valve is opened to broadcast spray with the boom.
- ◆ Bypass valve is opened to re-circulate solution back into the tank.

When spraying with either the boom or the handgun, pressure may be reduced by slowly opening the bypass valve until desired pressure is achieved (Detail B). Opening the valve decreases pressure, closing the valve increases pressure. When spraying with the boom, the proper method to set the pressure is to open the boom valve completely and if a lower pressure is desired, then slowly open the bypass valve until that pressure is obtained.

For the safest and most efficient chemical application, you will need to calibrate your sprayer using the tip and speed charts. Once you have determined the proper speed and pressure settings, you will need to consult your chemical label for the amount of chemical to be added to the tank. Read the entire label. Use only according to label directions.

Calibration

Chemical labels may show application rates in gallons per acre, gallons per 1000 square feet or gallons per 100 square feet. You will note that the tip chart shows 3 of these rating systems. Once you know how much you are going to spray, then determine (from the tip chart) the spraying pressure (PSI), and the spraying speed (MPH).

Determining the proper speed of the pulling vehicle can be done by marking off 100, 200 & 300 feet. The speed chart indicates the number of seconds it takes to travel the distances. Set the throttle and with a running start, travel the distances. Adjust the throttle until you travel the distances in the number of seconds indicated by the speed chart. Once you have reached the throttle setting needed, mark the throttle location so you can stop and go again, returning to the same speed.

Add water and proper amount of chemical to the tank and drive to the starting place for spraying.

Manifold Valves CLOSED

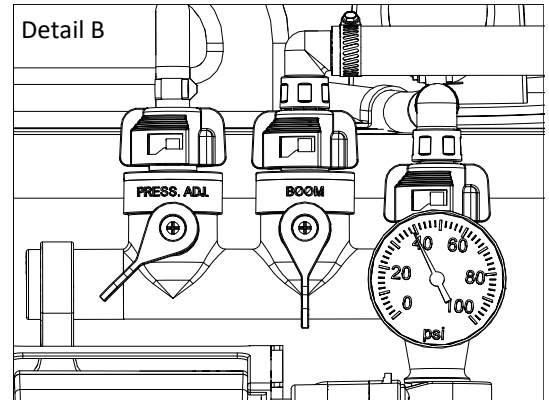
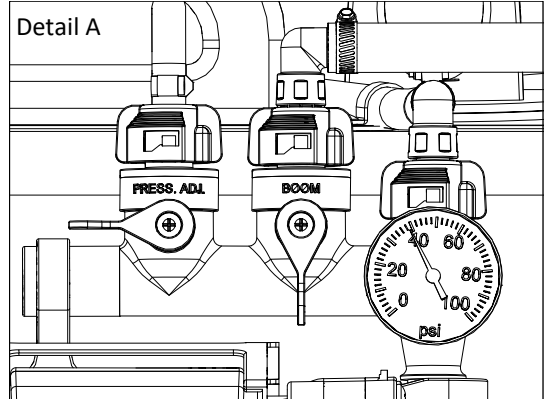
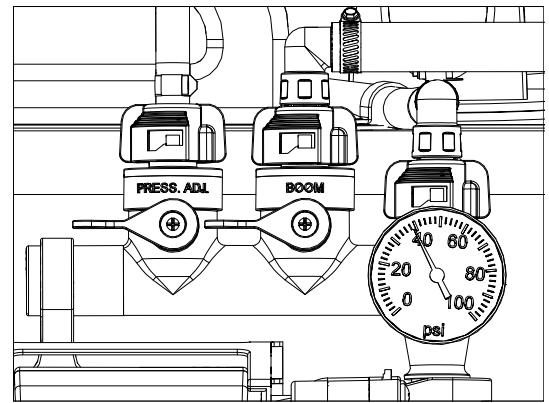

Speed Chart			
	Time Required in seconds to travel a distance of		
Speed in M.P.H. (Miles Per Hour)	100 Ft.	200 Ft.	300 Ft.
1.0	68 sec.	136 sec.	205 sec.
2.0	34	68	102
3.0	23	45	68
4.0	17	34	51
5.0	14	27	41
6.0	11	23	34
7.0	9.7	19	29
8.0	8.5	17	26
9.0	7.6	15	23
10.0	6.8	14	20

Rate Chart for Boomless Nozzle (Set of 3)								
Gallons per Acre Based on Water - 17-1/2" Spacing								
Pressure P.S.I.	Capacity G.P.M. (3 Nozzles)	1 MPH	2 MPH	3 MPH	4 MPH	5 MPH	6 MPH	8 MPH
20	1.68	28.0	14.0	9.4	7.0	5.6	4.7	3.5
30	2.05	34.4	17.2	11.4	8.6	6.9	5.7	4.3
40	2.40	39.6	19.8	13.2	9.9	7.9	6.6	5.0
Gallons per 1000 Sq. Ft. Based on Water - 17-1/2" Spacing								
Pressure P.S.I.	Capacity G.P.M. (3 Nozzles)	1 MPH	2 MPH	3 MPH	4 MPH	5 MPH	6 MPH	8 MPH
20	1.68	0.64	0.32	0.21	0.16	0.13	0.11	0.08
30	2.05	0.78	0.39	0.26	0.20	0.16	0.13	0.10
40	2.40	0.90	0.45	0.30	0.23	0.18	0.15	0.12
Gallons per 100 Sq. Ft. Based on Water - 17-1/2" Spacing								
Pressure P.S.I.	Capacity G.P.M. (3 Nozzles)	1 MPH	2 MPH	3 MPH	4 MPH	5 MPH	6 MPH	8 MPH
20	1.68	0.064	0.032	0.021	0.016	0.013	0.011	0.008
30	2.05	0.078	0.039	0.026	0.020	0.016	0.013	0.010
40	2.40	0.090	0.045	0.030	0.023	0.018	0.015	0.012

** The rate of spray as shown in the chart will remain the same with 1, 2 or 3 Nozzles **
The only difference will be with the width of the spray swath

Using the Boom Nozzles

Four things must be considered before spraying with the boom.

1. How much chemical must be mixed in the tank.
 2. Rate of spray (gallons per acre to be sprayed).
 3. What pressure (p.s.i.) will be used.
 4. Speed traveled (mph) while spraying.
- * Refer to the chemical label to determine your chemical mixture.
 - * See the tip chart to determine the pressure to be used. The chart will also show the speed used when spraying.
 - * Start the pump and open the valve to the boom nozzles.
 - * Check the spray pattern. Usually you can see the coverage better on a solid concrete surface, such as a driveway.
 - * Approximate height: 33"

- The (3) nozzles are fixed at 17-1/2" spacing
- All (3) nozzles spraying at the same time will allow a maximum coverage of 30 feet
- The center nozzle will spray an 80" swath
- Each of the (3) nozzles has a shutoff valve, so you can shut off each nozzle individually. This may help in achieving the actual coverage needed for your application.

Maintenance During/After Spraying

Periodically check the strainer and clean the screen on your intake line.

Proper care and maintenance will prolong the life of your sprayer.

After use, drain the tank and store or dispose of chemical properly. Fill the sprayer half way with clean water. Start the pump and allow the water to pump through the entire plumbing system and nozzles. Drain and then refill half full, add the recommended amount of a good quality tank cleaner, such as FIMCO Tank Neutralizer and Cleaner. (If no tank cleaner is available, you may substitute dish soap for this step, about 1-2 oz. per gallon). Turn pump on and circulate through system for 15 minutes and then spray out through boom and handgun nozzles. Refill sprayer half way with clean water and repeat. Follow the chemical manufacturer's disposal instructions of all wash or rinsing water.

If boom or handgun nozzles need cleaning, remove them from the sprayer and soak in warm soapy water. Clean with a soft bristled brush or toothpick if necessary. Never use a metal object. Even the slightest damage can change the flow rate and spray distribution. Water rinse and dry the tips before storing.

WARNING: Some chemicals will damage the pump valves if allowed to soak untreated for a length of time! ALWAYS flush the pump as instructed after each use. DO NOT allow chemicals to sit in the pump for extended times of idleness. Follow the chemical manufacturer's instructions on disposal of all waste water from the sprayer.

Winter Storage

Prepare the sprayer for end-of-season storage by running RV antifreeze through the system. This will keep internal parts lubricated, protect against corrosion and keep the unit from freezing. *Note: RV antifreeze is non-toxic and biodegradable and generally safer for the environment than automotive antifreeze.*

Before storing your sprayer for winter or long term storage, thoroughly clean and drain it as much as possible. Then pour enough pink RV antifreeze into the tank so that when the pump is turned on you can pump the antifreeze throughout the entire plumbing system, including the bypass. Make sure to operate the boom and handgun until you see pink fluid spraying from the nozzles. Leave any remaining antifreeze in the tank. Before your next usage, rinse the antifreeze from the sprayer with clean water.

It is nearly impossible to drain all of the water from the sprayer and any trapped water can freeze in cold weather and damage parts of the sprayer. Pumping the antifreeze through the system will displace the water and help prevent this damage.

Removing from storage: drain the antifreeze. Fill the tank with fresh water and run through the system. Dispose of antifreeze and flush water properly.

STOP WARNING STOP

DO NOT USE PUMP IN AN EXPLOSIVE ENVIRONMENT. DO NOT USE TO PUMP FLAMMABLE/COMBUSTIBLE FLUIDS, GASOLINE, KEROSENE, FUEL, OIL, ETC.

**HIGH FLO
HIGH PERFORMANCE**

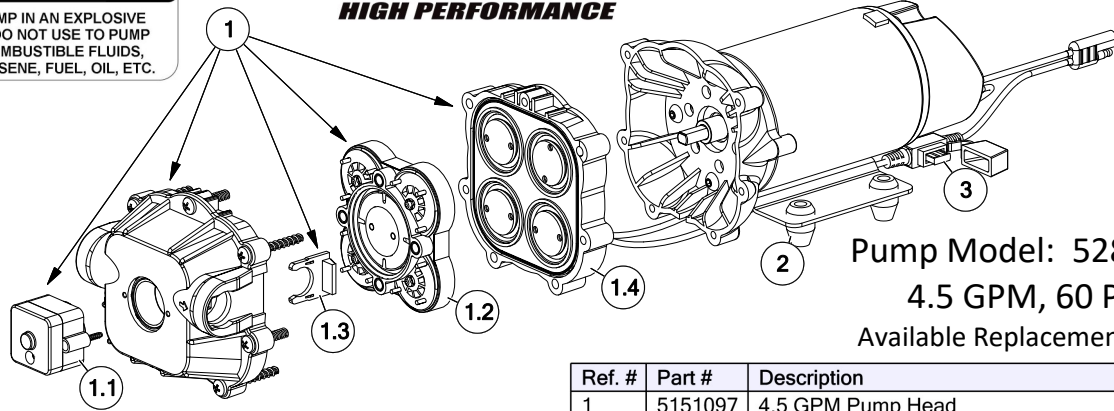

Pump Model: 5281372
4.5 GPM, 60 PSI
Available Replacement Parts

Replacement Pump: 5151088

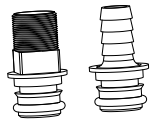

Includes:
1/2" MNPT Port Kit Fitting #5168832
1/2" Hose Barb Port Kit Fitting #5168833

Ref. #	Part #	Description	Qty
1	5151097	4.5 GPM Pump Head	1
1.1	5164271	60 PSI Pressure Switch	1
1.2	5168824	Check Valve w/O-Ring	1
1.3	5051162	Pump Slide Clips (Pkg/2)	1
1.4	5063271	4.5 GPM Diaphragm/Piston/Cam/Bearing Kit	1
2	5075019	Grommets (Pkg/4)	1
3	5157206	15 Amp 'Mini Blade' Fuse	1

DO

- Clean and rinse your pump after each use with Fimco Tank Neutralizer
- Winterize your pump or sprayer by rinsing, draining and running RV Antifreeze through it before storing for the winter.
- Use clean water for your spray mixture
- Store inside a building when not in use.

DON'T

- Use to pump bleach.
- Use to pump petroleum products such as diesel fuel, gasoline or kerosene
- Leave your pump sit with spray mixture in it for extended periods
- Use dirty or unfiltered water for spraying

CAUTION

PRESSURE SWITCH OPERATION

Pressure switch is pre-set at the factory. Improper adjustment of the pressure switch, may cause severe overload or premature failure. If the pump is subjected to rapid cycling during normal operation, or infrequent periods, damage may occur.

Troubleshooting the Pump:

Motor does not run:

- Check for loose wiring connection(s).
- Check for defective pressure switch.
- Check the fuse.
- Check for low voltage at the power supply.

Pump does not prime:

- Check for air leaks in supply line.
- Check for debris in the check valve assembly.
- Check for defective check valve.
- Check for clogged strainer/filter.
- Check for cracks in the pump housing.
- Check for empty product supply.

Low Pressure/Low Flow:

- Check for leaks in the discharge line.
- Check for restriction in the discharge line.
- Check for debris in nozzle orifice.
- Check for clogged strainer.
- Check for proper voltage—try another battery or recharge battery.

Pulsating flow (surging):

- Low flow may cause pump to surge.
- Spray wand is adjusted for a small or fine spray pattern.
- Slightly open bypass (if applicable) to overcome.

- If needed, pressure switch may need to be adjusted—adjust a quarter turn at a time clockwise until surging stops.
- Check for defective pressure switch.
- Check for leaks in the discharge line.
- Check for restriction in the discharge line.
- Check for debris in nozzle orifice.
- Discharge hose may be too long.
- Check for clogged strainer.

Motor continues to run after discharge is shut off:

- Check for empty product supply.
- Check for open bypass valve. (if equipped)
- Check for low voltage.
- Check for leak in discharge line.
- Check for defective pressure switch.
- System has leaks.

Fuse blows:

- Excessive voltage.
- Improper adjustment of pressure switch.
- Defective pressure switch.

Checking the Pressure Switch:

If your motor is not running and you've checked the following: for loose wiring connections, fuse, the switch on the lead wire was "ON" and made sure you were connected to a fully charged battery and everything is fine, but the motor won't run, then it's time to check to see if the pressure switch is bad.

- Remove the cover off the 1" square box (pressure switch) on the head of the pump, the cover is held on by one phillips-head screw. This will expose the two red wires.
- With the pump connected to a good 12 volt power source and everything on.
- Slip the two red wires off the terminals and touch them together.

If the motor runs, it means the pressure switch is bad and needs to be replaced.

Warning: It is NOT recommended to run the pump this way, as the pump will continue to run and not shut off.

This could result in blown hoses when all discharges are closed. Also, this could result in premature failure of the pump completely.

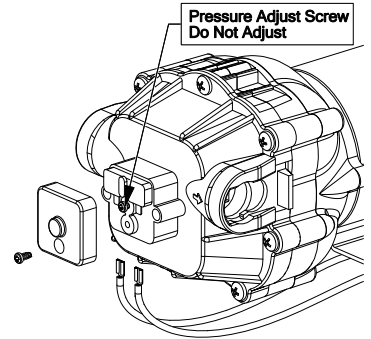

Cleaning the Check Valve:

If you're experiencing little to no pressure or the pump is not priming and you've checked your filter screen and it's clean, and you've gone through the other trouble shooting tips, you may need to clean the check valve.

- Remove the head of the pump, which is held on by 7 screws.
- The first piece inside the head of the pump is called a check valve, it's the part responsible for building up pressure and pumping water/solution through the lines.
- Clean the check valve under hot, soapy water (such as a good grade dish soap).
- Give it a very light scrubbing with something like an old toothbrush, something with soft bristles.
- Then let it soak for about an hour or so in the hot soapy solution and replace in the pump and reassemble the pump.

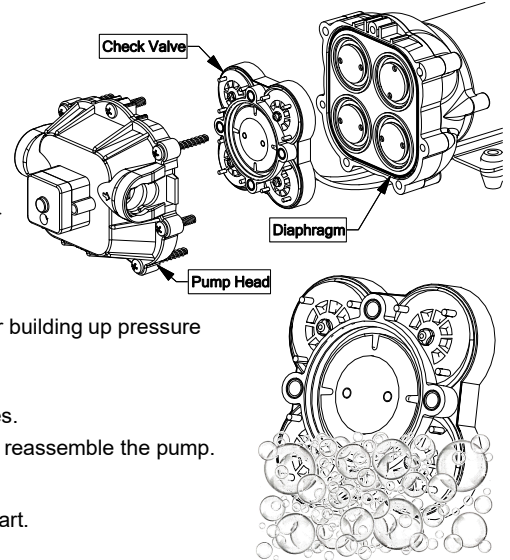

Most times this will restore most, if not all of the prime of a pump. If you're still having issues with pressure after this step, it would be recommended to replace this part.

Troubleshooting	
Pump will not run:	Check for loose wiring
	Make sure the ON/OFF switch is on
	Check the fuse
	Check for defective pressure switch
Low Pressure/Low Flow:	Check for a clogged strainer
	Check for proper voltage
	Check for worn or dirty check valve
Pump surges:	Low flow may cause pump to surge
	Spray wand is adjusted for a small or fine spray pattern
	Slightly open bypass (if applicable) to overcome
	If needed, pressure switch may need to be adjusted Quarter turn at a time clockwise until surging stops
Pump continues to run:	Bypass (if applicable) is not completely closed
	System has leaks
	Check that shut-off valve on inlet (if applicable) is open
	Check for worn or dirty check valve
Fuse blows:	Excessive voltage
	Improper adjustment of pressure switch
	Defective pressure switch

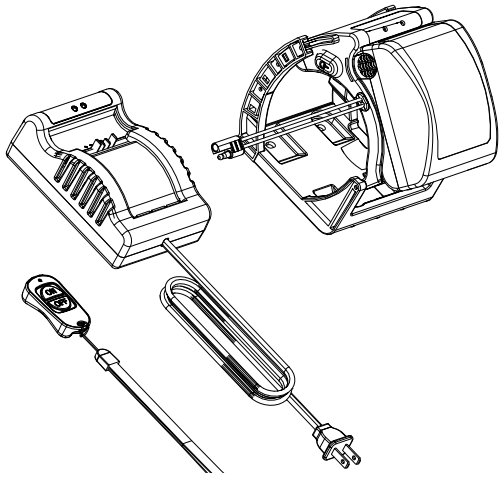

20V, 5A Lithium Battery Kit (5281506)

Instruction Manual for Volt Edge 20V max* Li-ion Battery Charger

* Maximum initial battery pack voltage (measured without a workload) is 20 volts. Measured under workload, nominal voltage is 18 volts.

The label on your product may include the following symbols.

V volts

A Amperes

Hz Hertz

Ah Amp hours

— Direct Current

 Safety Alert Symbol

Wh Watt Hours

~ Alternating Current

 Read Owner's Manual

 Recycle Battery

Important Safety Instructions - Save These Instructions.

Save these instructions: This manual contains important safety instructions for the components.

Warning: Before using, read and follow all instructions and cautionary markings on charger, battery pack and product using battery pack.

Warning: To reduce the risk of injury, basic safety precautions should always be followed including:

- Do not incinerate the battery pack, even if it is severely damaged or is completely worn out. The battery pack can explode in a fire. Toxic fumes and materials are created when the battery packs are burned.
- Do not charge or use battery in explosive atmospheres, such as in the presence of flammable liquids, gases or dust. Inserting or removing the battery from the charger may ignite the dust or fumes.
- If battery contents come into contact with the skin, immediately wash area with mild soap and water. If battery liquid gets into the eye, rinse water over the open eye for 15 minutes or until irritation ceases.
- Contents of opened battery cells may cause respiratory irritation. Provide fresh air. If symptoms persist, seek medical attention.

Warning: To reduce the risk of injury, basic safety precautions should always be followed including:

- Charge battery packs only in Volt Edge 20V max Lithium-ion compatible chargers.
- Do not store or charge the battery pack in locations where the temperature may reach above 95°F (35°C) or below 40°F (4°C).
- Do not use the battery pack in locations where the temperature may reach above 120°F (49°C) or below -4°F (-20°C).

Warning:

Never attempt to open the battery pack for any reason. If the battery pack case is cracked or damaged, do not insert into charger or other Volt Edge products. Do not crush, drop or damage battery pack. Do not use battery pack or charger that has received a sharp blow, been dropped, run over or damaged in any way. Damaged battery packs should be taken to a lithium battery recycling center.

Warning:

Fire hazard. Do not store or carry battery so that metal objects can contact exposed battery terminals. Transporting batteries can possibly cause fires, if the battery terminals inadvertently come in contact with conductive materials.

Warning:

Shock hazard. Do not allow any liquid to get inside charger.

Warning:

Burn hazard. To reduce the risk of injury, charge only designated Volt Edge 20Vmax batteries. Other types of batteries may burst, causing personal injury and damage.

Caution:

Under certain conditions, with the charger plugged into the power supply, the charger can be shorted by foreign material. Foreign materials of a conductive nature, such as, but not limited to, steel wool, aluminum foil or any buildup of metallic particles should be kept away from charger cavities. Always unplug the charger from the power supply when there is no battery pack in the cavity. Unplug charger before attempting to clean.

Warning:

- Do not attempt to charge the battery pack with any chargers, other than the ones in this manual. The charger and battery pack are specifically designed to work together.
- The chargers are not intended for any uses other than charging designated Volt Edge 20Vmax Lithium-ion batteries. Any other uses may result in risk of fire, electric shock or electrocution.
- Be sure voltage selector is in correct voltage position before plugging in.
- For use in the U.S.A., the voltage selector switch must be placed in the 120 volt position. For use in countries, other than the U.S.A., the voltage selector may need to be placed in other than the 120 volt position. Confirm the voltage available at each country location before using this product.
- Do not expose charger to rain or snow.
- Pull by plug, rather than cord when disconnecting charger. This will reduce the risk of damage to electric plug and cord.
- If the shape of the plug does not fit the power outlet, use an attachment plug adaptor of the proper configuration for the power outlet.
- Make sure that cord is located so that it will not be stepped on, tripped over or otherwise subjected to damage or stress.
- Do not use an extension cord, unless it is necessary. Use of improper extension cord could result in risk of fire, electric shock or electrocution.
- Do not operate charger with damaged cord or plug.
- Do not operate charger if it has received a sharp blow, been dropped or otherwise damaged in any way.
- Do not disassemble the charger.
- Disconnect the charger from the outlet before attempting any cleaning. This will reduce the rise of electric shock. Removing the battery pack will not reduce this risk.
- The charger is designed to operate on standard household electric power (120V). Do not attempt to use it on any other voltage.
- The power unit is intended to be correctly oriented in a vertical or floor mount position.

Declaration of Conformity:

This device complies with Part 15 of the FCC Rules. Operation is subject to the following two conditions:

- 1) This device may not cause harmful interference.
- 2) This device must accept any interference received, including interference that may cause undesired operation.

This device complies with:

- Appendix Y to Subpart B of Part 430-Uniform Test Method for Measuring the Energy Consumption of Battery Chargers. DOE energy conservation standards specified in the Code of Federal Regulations at 10 CFR 430.32(z).
- This device complies with CEC, Section 1605.1(w) of energy efficiency standards for federally regulated battery chargers of California Code of Regulations.
- This device complies with NRCAN(EEV), CSA-C381.2-17 May 2017 and Canada's Energy Efficiency Regulations.
- This device complies with cETLus certification based on Conforms to UL STD.1310 Certified to CSA STD.CC22 NO.223.

Storage Recommendations:

- The best storage place is one that is cool and dry, away from direct sunlight and excess heat or cold.
- Long storage will not harm the battery pack or charger.
- Do not store a battery connected to a charger.

Charging Instructions:

The battery pack is not fully charged out of the carton. Before using the battery pack and charger, read the safety instructions below. Then follow charging procedure.

Charging Procedure

1. Plug the charger into an appropriate outlet before inserting the battery pack. The green LED will flash once indicating the charger is ready to use.
2. Insert the battery pack into the charger.
3. The green LED will flash indicating the battery is being charged.



4. The completion of charger is indicated by the green LED remaining on continuously. The pack is fully charged and may be used at this time or left on the charger.
 - a. Recharge discharged batteries as soon as possible after use or battery life may be greatly diminished. For longest battery life, do not discharge batteries fully. It is recommended that the batteries be recharged after each use.



5. If the battery remains on the charger for more than 2 hours after charging is complete, the green LED will slowly blink.



Charger Diagnostics

This charger is designed to detect certain problems that can arise with the battery packs or the power source. Problems are indicated by the red and green LEDs.



Temperature Delay

When the charger detects a battery that is excessively hot or excessively cold, it automatically starts a Temperature Delay, suspending charging until the battery temperature returns to acceptable temperatures. The red LED will flash indicating the battery is outside the required temperature range and not charging. Once the temperature is within the required range, charging will begin.



Broken Battery

The charger can detect a weak or damaged battery. The red and green LED will alternate flashing. If you see this warning, do not continue to charge the battery and remove the battery from the charger.

Leaving the battery in the charger.

The charger and battery pack can be left connected with the green LED indicating the charger is maintaining the battery continuously. The charger will keep the battery pack fresh and fully charged.

Important charging notes:

1. Longest life and best performance can be obtained if the battery pack is charged with the air temperature is between 50°F (10°C) and 80°F (26°C).
2. The charger and battery pack may become warm to the touch while charging. This is normal and does not indicate a problem. Ensure the vents are not blocked to allow cooling.
3. The battery pack should be recharged when it no longer powers the equipment. Do not continue to attempt using the battery if low power is indicated. You may recharge a partially discharged battery pack without damaging the battery pack.
4. Do not freeze or submerge the charger in water or any other liquid.

Warning:

Shock Hazard. Do not allow any liquid to get inside the charger. Never attempt to open the battery pack for any reason. If the plastic housing of the battery pack breaks for cracks, return to a recycling center and replace the charger.

The receiver is designed to power all High-Flo 12V pumps. The receiver will output 12V DC and is limited to 15A max. current.

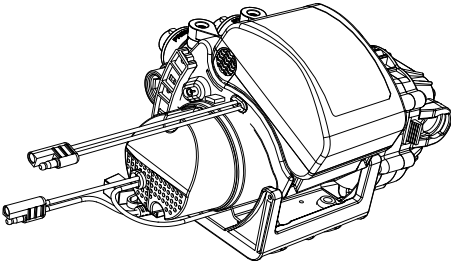

To install the receiver, the pump will be removed. The base plate and adjustable support will be placed under the pump and screwed down with the longer screws supplied in the kit. The receiver has already been pinned to the base plate, but it can be removed to make screw installation easier by sliding the pin out. Then the receiver is slid into the adjustable support bracket. It will click into the first position, sized for the Pro Series pumps and the 4.5 pump.

4.5 GPM Pump w/Manifold Configuration:

Place pump on base plate and screw down to tank or frame, using the (3) #10-24 x 1-1/4" and (1) #10-24 x 1-1/2" screws. The 1-1/2" screw goes through the manifold support bracket. Click the receiver into the first position of the adjustable support.

Operating Procedure:

1. Charge the battery following the charging procedure.
2. Ensure all fasteners are tight and pump connections are secure.
3. Install the battery ensuring the base is connected and it is fully seated.
4. Press the power button and confirm the green LED turns on. Signaling the power is on.
5. Test the remote by pressing the OFF button on the remote and both green and red receiver LEDs will turn on. Signaling the power output is off while the power is on.
6. Press the ON button on the remote. The red LED will turn off and power output will return.
7. Press the power button again to turn the receiver off.
8. Connect the receiver 2-pin connector to the pump.
9. Press the power button to turn the receiver on and the pump will run.
10. When spraying is complete press the power button to turn off the receiver.
11. Recharge the battery to properly maintain the battery pack.

Receiver Diagnostics:

The receiver is designed to detect certain problems that can arise with the battery packs or the pump. Problems are indicated by the red and green LEDs.

Battery Life



When the battery is approaching fully discharged, the green LED will begin to flash. When the battery is fully discharged, power will stop being supplied to the pump and the green LED will continue flashing. Power off the receiver and charge the battery.

Protection Mode



When the receiver identifies a problem with the pump, the power output will stop and the red LED will flash and the green LED will remain illuminated. The red LED will blink in cycles to identify the problem. Press the power button turning the receiver off to reset the system. Wait 30 seconds and press the power button to resume operation.

Red LED flashing two times: Open circuit protection. The receiver power is on without powering consumption.

Red LED flashing three times: Incorrect voltage. Voltage being supplied to the receiver is outside the range.

Red LED flashing four times: High current protection. The pump has drawn current above the limit.

Red LED flashing ten times: Temperature protection. The system has measured the temperature to be outside safe operating temperatures.

Remote Button Identification:

The small LED at the top of remote turns red when transmitting.

The red LED is also the pairing button.

The 'ON' button will only turn on the Volt Edge Receiver.

The 'OFF' button will only turn off the Volt Edge Receiver.

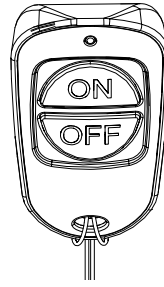

Pairing Procedure:

1. Ensure the receiver power cord is not connected.
2. Install a charged battery pack into the receiver.
3. Power ON the Volt Edge receiver. Within 15 seconds press and hold the pairing button for 5 seconds. The green LED on the receiver will quickly turn off and back on when pairing is successful.
4. Power OFF the Volt Edge receiver.
5. Power ON the Volt Edge receiver and press the OFF and then ON button to confirm pairing is successful.

Storage Recommendations:

- The best storage place is one that is cool and dry, away from direct sunlight and excess heat, cold or moisture.

Remote Capabilities:

- The remote can control the receiver up to 50 feet away. Obstructions and radio interference can reduce the effective distance.
- A remote can be paired to multiple receivers at one time.
- A receiver can only be paired to one remote at a time.
- A receiver/remote relationship can only be separated by pairing with another remote.

FCC WARNING:

Please note that changes or modifications of this product is not expressly approved by the party responsible for compliance, could void the user's authority to operate the equipment.

FCC STATEMENT:

NOTE: This equipment has been tested and found to comply with the limits for a Class B digital device, pursuant to Part 15 of the FCC Rules. These limits are designed to provide reasonable protection against harmful interference in a residential installation. This equipment generates, uses and can radiate radio frequency energy and, if not installed and used in accordance with the instructions, may cause harmful interference to radio communications.

However, there is no guarantee that interference will not occur in a particular installation. If this equipment does cause harmful interference to radio or television reception, which can be determined by turning the equipment off and on, the user is encouraged to try to correct the interference by one or more of the following measures:

- ◇ Reorient or relocate the receiving antenna.
- ◇ Increase the separation between the equipment and receiver.
- ◇ Connect the equipment into an outlet on a circuit different from that to which the receiver is connected.
- ◇ Consult the dealer or an experienced radio/TV technician for help.

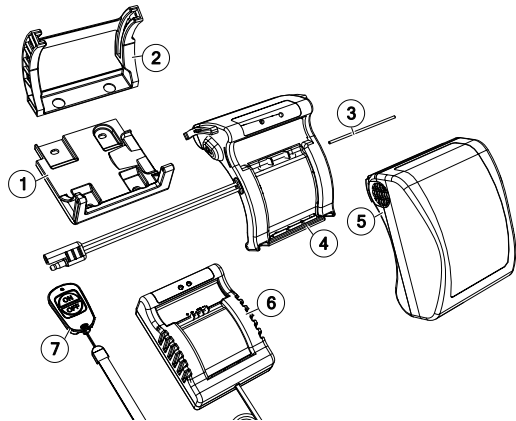

**Exploded View/Parts List
20V, 5A
Lithium Battery Kit (5281506)**

Ref. #	Part #	Description	Qty
1	5058222	20V Receiver Base Plate	1
2	5058223	20V Receiver Adjustable Support	1
3	5058224	SS Receiver Pin 3mm X 108mm	1
4	5164285	20V Battery Receiver 15A	1
5	5164275	20V 5AH Lithium Battery Pack	1
6	5164281	20V 1A Lithium Battery Charger	1
7	5164291	Wireless Remote	1

Declaration of Conformity:

This device complies with Part 15 of the FCC Rules. Operation is subject to the following two conditions:

- 1) This device may not cause harmful interference.
- 2) This device must accept any interference received, including interference that may cause undesired operation.



TROUBLESHOOTING		
Problem	Possible Cause	Possible Solution
Battery will not charge	Charger not plugged in	Plug charger into a working outlet. Check outlet with another device.
	Temperature is too hot or too cold	Move charger and battery to a climate-controlled environment and wait for the product to reach room temperature.
	Battery pack not inserted into charger	Remove battery pack and re-install battery pack. Ensure the bottom edge of the battery is seated first, then push the clips in.
Remote does not control the receiver	Remote battery is discharged	Replace the battery with CR2032 size button cell battery.
	Receiver is not on	The green light must be illuminated on the receiver for the remote to control it.
	Remote is not paired with receiver Radio Interference	Follow the Pairing Instructions to pair a remote and receiver. Move the receiver and remote away from the electronic interference.
Receiver does not power pump & green LED is off	Battery not connected	Remove battery pack and carefully reinstall.
	Battery discharged	Remove battery, charge and reinstall.
Receiver does not power pump & green LED is on	Bad electrical connection	Follow wires from receiver to plug. Disconnect and reconnect 2-pin plug.
	Pump fuse is blown	Check fuse on pump wire and replace if necessary.

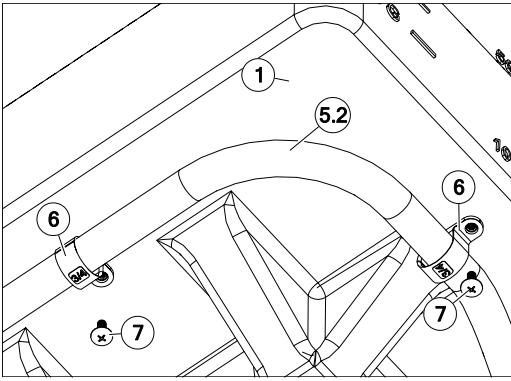

Intake attachment to tank.
Refer to Page 14 for the UTV intake assembly
breakdown. Reference #5.

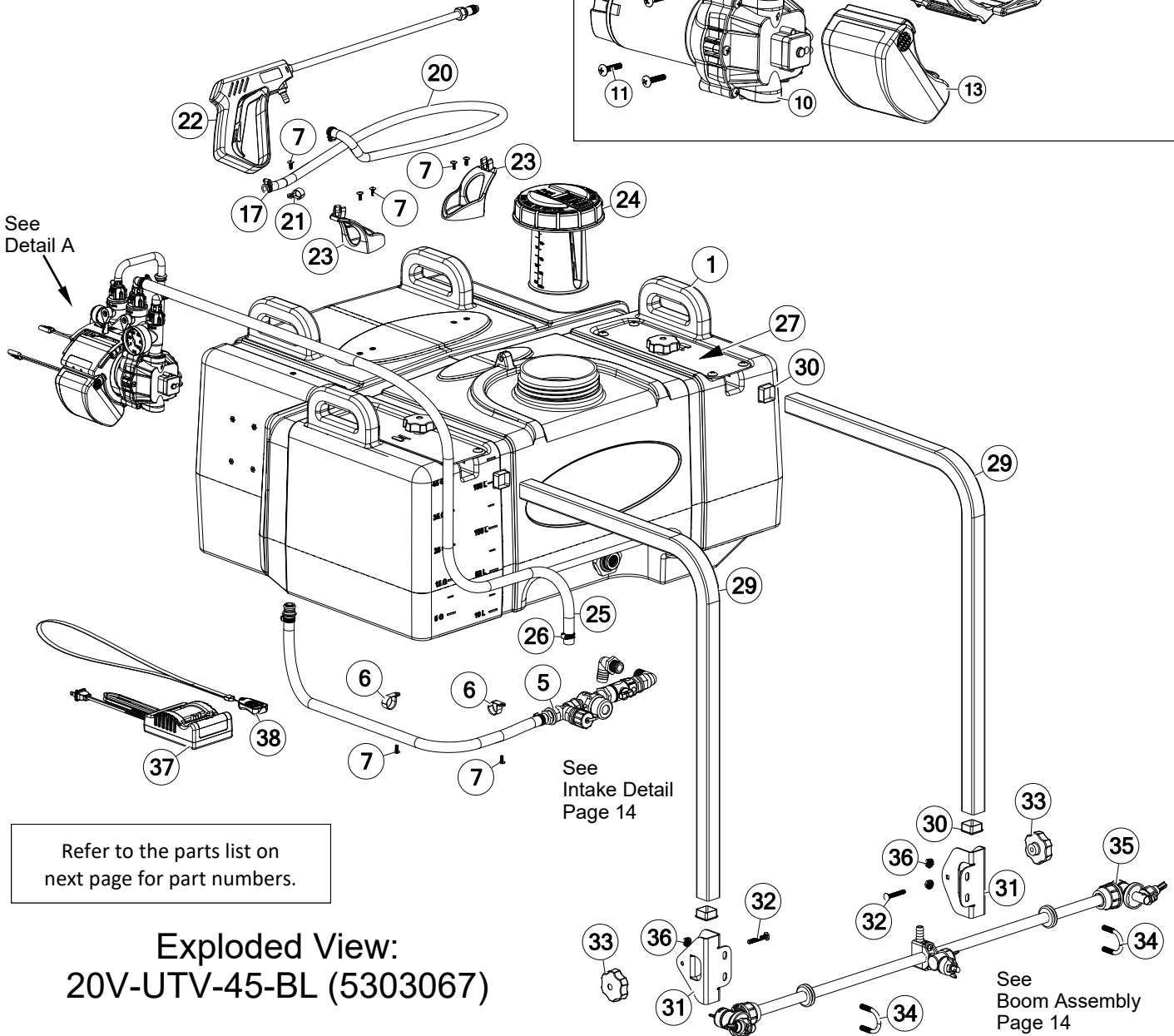
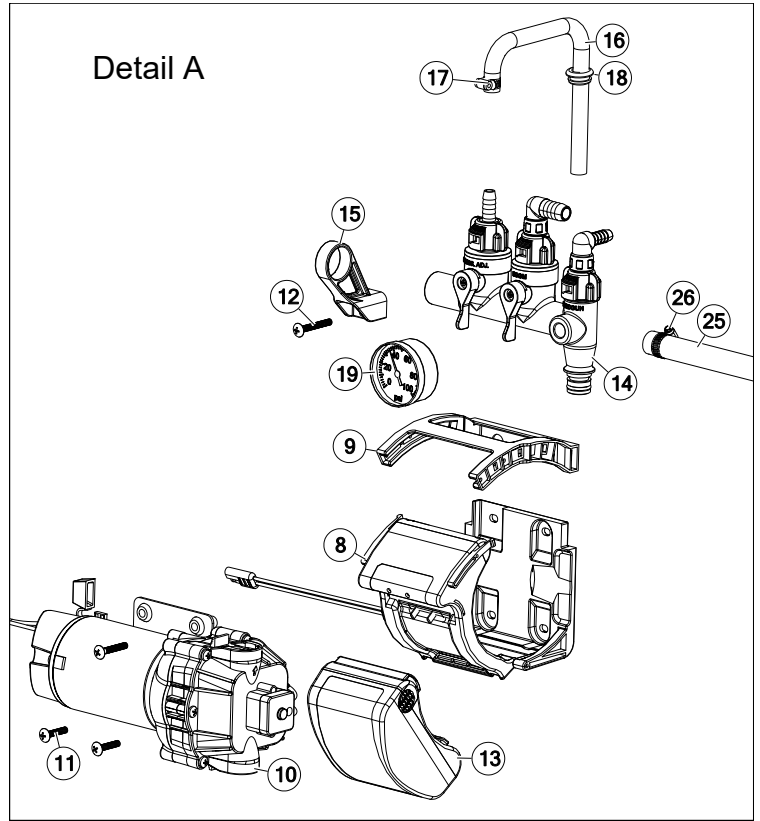

Refer to the parts list on
next page for part numbers.

Exploded View: 20V-UTV-45-BL (5303067)

Parts List: 20V-UTV-45-BL (5303067)

Ref. #	Part #	Description	Qty
1	5169329	45 Gallon UTV Tank w/Bulkhead Fitting	1
1.1	TF50DTN	Polypro 1/2" Bulkhead Fitting	1
2	5010205	Poly Elbow, 1/2" MNPT x 3/4" HB	1
3	5010243	Poly Street Elbow, (90 Deg) 1/2" MNPT x 1/2" FNPT	1
4	5005195	Poly Adapter, 1/2" MNPT x 3/4" MGHT	1
5	5278928	45G UTV Intake Plumbing Assembly	1
5.1	5278717	UTV Intake Plumbing	1
5.1.1	5143419	Swivel Shut-Off	1
5.1.2	5016066	1" Rubber Washer	1
5.1.3	5005190	Poly Adapter Coupler, 3/4" FGHT x 1/2" FNPT	1
5.1.4	5116417	Poly Inline Strainer 1/2" MNPT	1
5.1.4.1	5046451	Poly Strainer Cap	1
5.1.4.2	5072533	Strainer O-Ring	1
5.1.4.3	5116452	Strainer Screen	1
5.1.4.4	5058205	Clear Strainer Bowl	1
5.1.5	5010230	Poly Tee, 1/2" FNPT	1
5.1.6	5005195	Poly Adapter, 1/2" MNPT x 3/4" MGHT	1
5.1.7	5274373	Drain Plug Cap Assembly	1
5.1.8	5067131	Poly Fitting, 1/2" MNPT x 1/2" HB	1
5.2	5020578	1/2" Polyspring Hose x 31"	1
5.3	5051114	Hose Clamp (1/2")	2
5.4	5168833	Port Kit Fitting, 1/2" Hose Barb	1
6	5051152	3/4" Black Nylon Loom Clamp	2
7	5117234	#10-24 x 1/2" Phillips Round Head Machine Screw	7
8	5281510	20V Receiver Sub Assembly	1
8.1	5058222	20V Receiver Base Plate	1
8.2	5058224	SS Receiver Pin 3mm X 108mm	1
8.3	5164285	20V Battery Receiver 15A	1
9	5058223	20V Receiver Adjustable Support	1
10	5281372	High-Flo High Performance 4.5 GPM Pump, 60 PSI	1
11	5117166	#10-24 x 1.25 Phillips Truss Head Machine Screw	3
12	5117338	#10-24 x 1.50 Phillips Truss Head Machine Screw	1
13	5164275	20V 5AH Lithium Battery Pack	1
14	5281539	Quick Connect Manifold Assembly	1
14.1	5302347	Quick Connect Manifold (Main Body)	1
14.1.1	5072514	O-Ring - Pump Port Connection	1

Ref. #	Part #	Description	Qty
14.2	5143430	Flat Washer - Hose Barb Seal	1
14.3	5143431	QC Manifold - 3/8" Hose Straight Barb	1
14.4	5143429	QC Manifold - Quick Connect Quarter Turn Cap	1
14.5	5302354	QC Manifold 1/2 Swivel 90° Elbow Assembly	1
14.6	5302802	QC Manifold 3/8 Swivel 90° Elbow Assembly	1
15	5143422	Quick Connect Manifold - Support Bracket	1
16	5100962	Formed Bypass Tube 1.5" x 4.25" x 5.0", 3/8" ID	1
17	5051144	Hose Clamp (3/8")	3
18	5075018	Grommet, 1/2" ID	1
19	5167097	2" Dry 100# Back Mount Gauge	1
20	5020527	Hose, 3/8"-1 Brd. x 25 Ft.	1
21	5051122	5/8" Black Nylon Loom Cable Clamp	1
22	5273959	Deluxe Pistol-Grip Handgun w/X-26 Tip	1
22.1	5018351	Brass Handgun Tip (X-26)	1
23	5133276	30 Gal. Hose Wrap	2
24	5058200	32 oz -1000 ml Multi-LID Complete Assembly	1
25	5020152	Hose, 1/2"-1 Brd. x 6 Ft. (72")	1
26	5051114	Hose Clamp (1/2")	2
27	5278715	UTV Boom Mount	2
27.1	5095394	Tank Boom Mount	1
27.2	5095393	Boom Clamp	1
27.3	5088026	5 Lobe Knob 1/4-20UNC	1
27.4	5034527	1/4-20 x 1.50 Carriage Bolt	1
28	5117342	5/16"-18 x 1/2" Phillips Truss Head Machine Screw	8
29	5095395	UTV Boom Mount	2
30	5046448	Square Cap, Black (1 1/4" x 14 Ga. Square Tube)	4
31	5051151	Boom Clamp	2
32	5034807	1/4-20nc X 1.75" Carriage Bolt	2
33	5088026	5 Lobe Knob 1/4-20UNC	2
34	5034220	5/16-18 x 1.3125 x 1.75 Round U-Bolt	2
35	5275260	"Wet Boom" Assembly	1
36	5006307	5/16-18nc Hex Flanged Whiz Nut Gr. 5	4
37	5164281	20V 1A Lithium Battery Charger	1
38	5164291	Wireless Remote	1

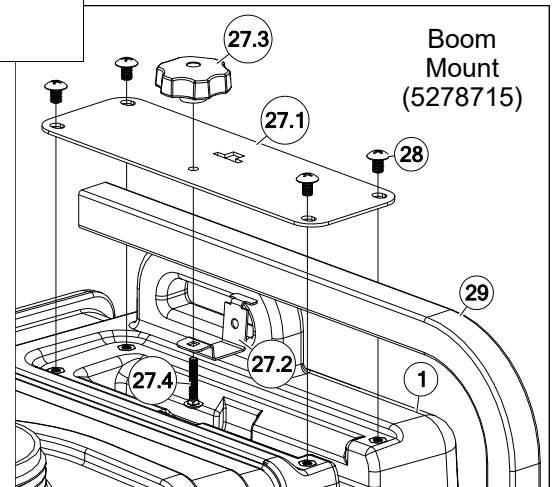
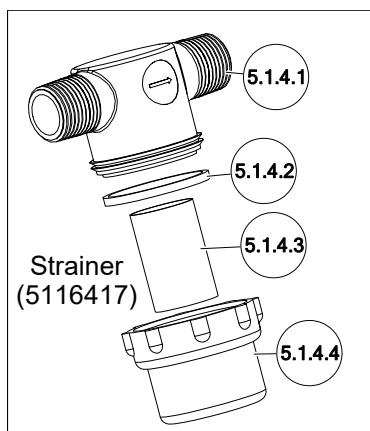
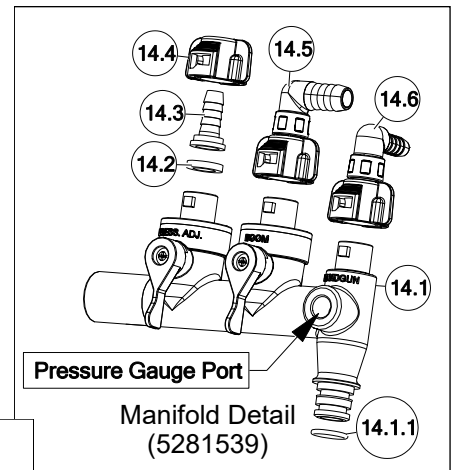
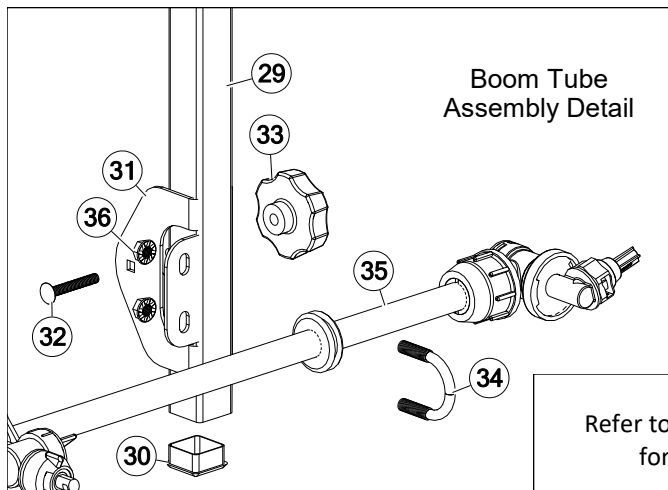

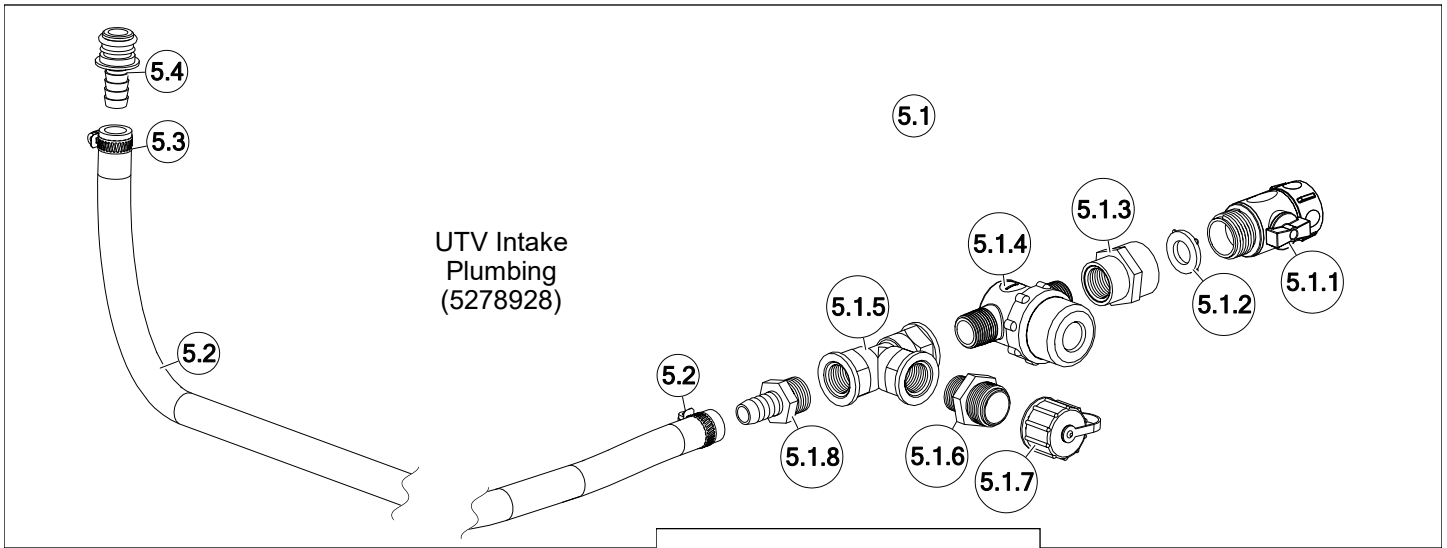

Refer to the parts list on page 13 for part numbers.

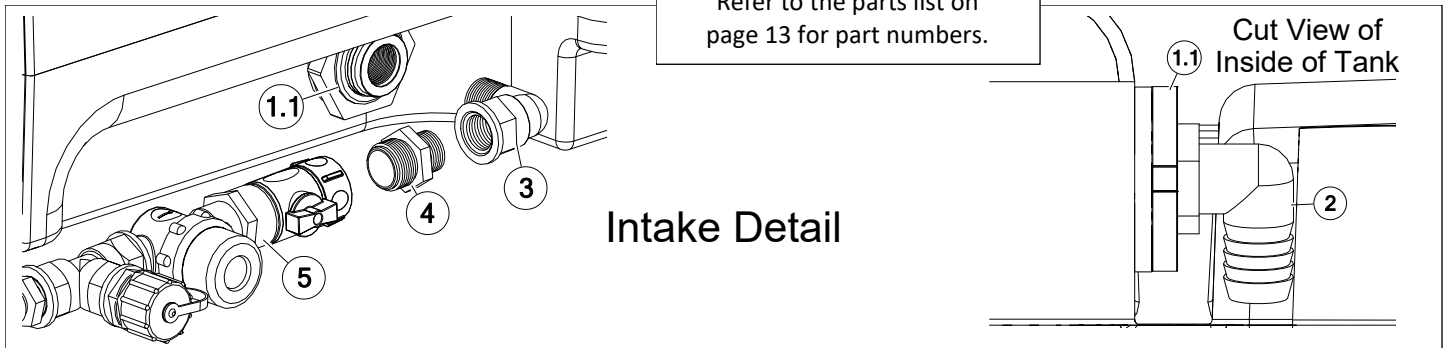

Boomless "Wet" Boom Assembly Exploded View/Parts List (5275260)

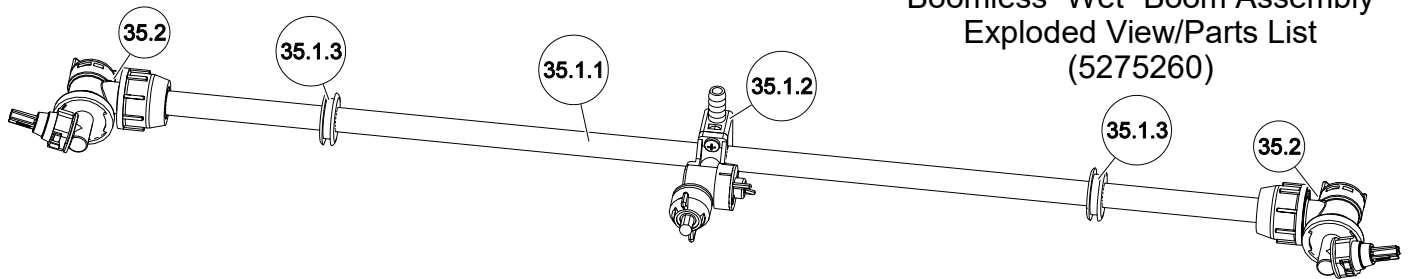

Ref. #	Part #	Description	Qty
35	5275260	"Wet Boom" Assembly	1
35.1	5275712	Wet Boom Sub-Assembly	1
35.1.1	5100316	Boom Tube	1
35.1.2	5275123	Center Nozzle Assembly (Wet Boom)	1
35.1.2.1	5274862	Center Boomless Nozzle Cap w/Gasket	1
35.1.2.2	5018329	Center Spray Tip	1
35.1.2.3	5088024	Valve (On/Off) Knob w/Diaphragm	1

Ref. #	Part #	Description	Qty
35.1.2.3.1	5063255	Diaphragm	1
35.1.3	5075016	Rubber Grommet	2
35.2	5275122	End Nozzle Assembly (Wet Boom)	2
35.2.1	5274861	XT Spray Nozzle, Cap, & O-Ring	1
35.2.2	5088024	Valve (On/Off) Knob w/Diaphragm	1
35.2.2.1	5063255	Diaphragm	1

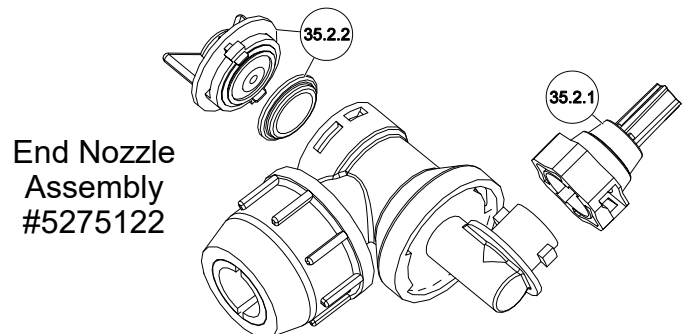
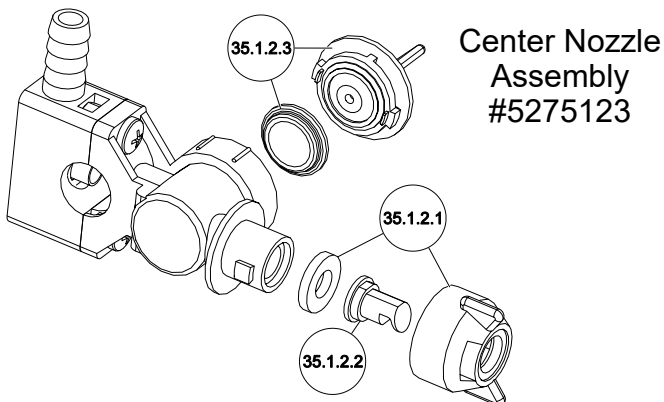

Technical Specifications

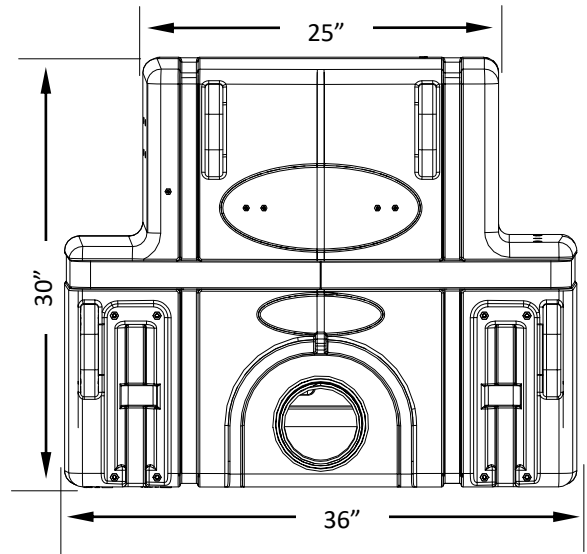
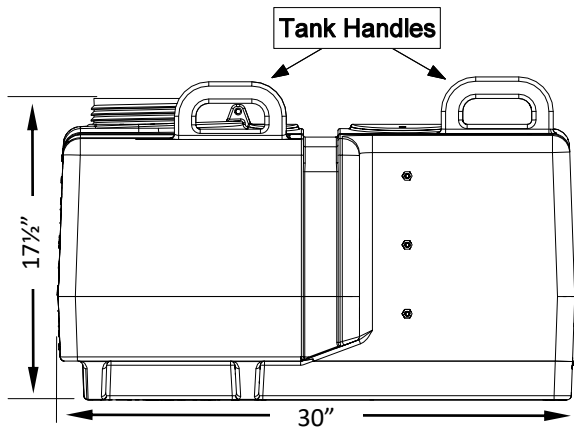

- ◆ Properly secure the tank to your utility vehicle, using tie-down or ratchet straps (Not Included).
- ◆ Tank straps may be installed through the handles to help prevent straps from slipping off tank if too loose.
- ◆ Handles can be used to lift the empty tank in and out of the box.
- ◆ Stay within your utility vehicle's weight limits. This unit when filled with water weighs approximately: 505 lbs. Consult the owner's manual for your vehicle.

There is a shut-off valve on the intake line. It is at this location so you can shut off the flow of solution to access your system's filter screen for cleaning.

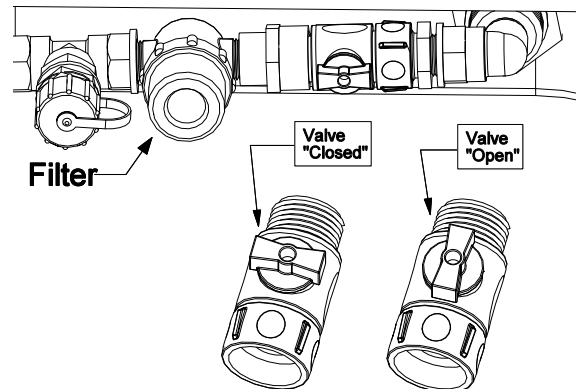

Checking/Cleaning the sprayer's filter/screen:

- ◆ Start your pump and before it shuts off, reach down and shut the valve to the 'Closed' position (lever is perpendicular to the flow of fluid), then shut off your pump.
- ◆ Unscrew the bowl of the filter to access the screen.
- ◆ Remove the screen and clean as necessary. Replace when done and reassemble the entire assembly.
- ◆ Make sure the valve is turned to the 'Open' position before restarting your pump.

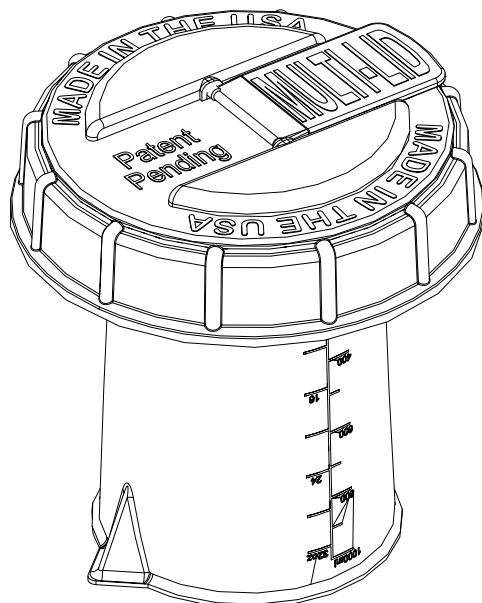

Multi-Lid Directions

1. Open fill cap and place garden hose into tank. Fill tank to desired gallon marker, if marker is above the bottom of calibration container, stop before water reaches calibration container. This is done to help chemical mix better and keep foaming of chemical to a minimum later.
2. Remove Multi-Lid and use calibration container to measure the correct amount of chemical for the water being used.
3. Pour chemical into tank and tighten Multi-Lid back onto tank. If desired amount of water was added in step 1, you are done. Be sure to press firmly on fill cap to seal with Multi-Lid. If desired amount of water was not met in step 1, proceed to step 4.
4. Open fill cap and place garden hose into tank. Add water to the desired gallon marker. Close fill cap, pressing firmly to seal cap to Multi-Lid.

NOTE: If water and chemical has not mixed properly, use the pressure adjustment control on the manifold to recirculate the mixture through tank.

Warranty

LIMITED WARRANTY FOR NEW FIMCO, IND. EQUIPMENT

WHO MAY USE THIS LIMITED WARRANTY. This limited warranty (the "Limited Warranty") is provided by Fimco, Ind. to the original purchaser ("you") of the Equipment (as defined below) from Fimco, Ind. or one of Fimco, Ind.'s authorized dealers. This Limited Warranty does not apply to any subsequent owner or other transferee of the Equipment. THIS LIMITED WARRANTY GIVES YOU SPECIFIC LEGAL RIGHTS, AND YOU MAY ALSO HAVE OTHER RIGHTS WHICH VARY FROM STATE TO STATE.

WHAT THIS LIMITED WARRANTY COVERS AND FOR HOW LONG. Fimco, Ind. warrants that any new Equipment will be free from defects in material and workmanship for a period of **one (1) year** for sprayer and **two (2) years** for High-Flo High Performance pump (homeowner), **90 days** for sprayer and pump (commercial user), after delivery of the Equipment to you (the "Warranty Period"). The Warranty Period is not extended if Fimco, Ind. repairs or replaces the Equipment.

WHAT IS NOT COVERED BY THIS LIMITED WARRANTY. This Limited Warranty does not apply to: (1) used Equipment; (2) any Equipment that has been altered, changed, repaired or treated since its delivery to you, other than by Fimco, Ind. or its authorized dealers; (3) damage or depreciation due to normal wear and tear; (4) defects or damage due to failure to follow Fimco, Ind.'s operator's manual, specifications or other written instructions, or improper storage, operation, maintenance, application or installation of parts; (5) defects or damage due to misuse, accident or neglect, "acts of God" or other events beyond Fimco, Ind.'s reasonable control; (6) accessories, attachments, tools or parts that were not manufactured by Fimco, Ind., whether or not sold or operated with the Equipment; or (7) rubber parts, such as tires, hoses and grommets.

HOW TO OBTAIN WARRANTY SERVICE. To obtain warranty service under this Limited Warranty, you must (1) provide written notice to Fimco, Ind. of the defect during the Warranty Period and within **thirty (30) days** after the defect becomes apparent or the repair becomes necessary, at the following address: Fimco, Ind., 1000 Fimco Lane, North Sioux City, SD 57049; and (2) make the Equipment available to Fimco, Ind. or an authorized dealer within a reasonable period of time. For more information about this Limited Warranty, please call: **800-831-0027**.

WHAT REMEDIES ARE AVAILABLE UNDER THIS LIMITED WARRANTY. If the conditions set forth above are fulfilled and the Equipment or any part thereof is found to be defective, Fimco, Ind. shall, at its own cost, and at its option, either repair or replace the defective Equipment or part. Fimco, Ind. will pay for shipping and handling fees to return the repaired or replacement Equipment or part to you.

LIMITATION OF IMPLIED WARRANTIES AND OTHER REMEDIES. THE REMEDIES DESCRIBED ABOVE ARE YOUR SOLE AND EXCLUSIVE REMEDIES, AND FIMCO, IND.'S SOLE LIABILITY, FOR ANY BREACH OF THIS LIMITED WARRANTY. TO THE EXTENT APPLICABLE, ANY IMPLIED WARRANTIES, INCLUDING, WITHOUT LIMITATION, THE IMPLIED WARRANTIES OF MERCHANTABILITY AND FITNESS FOR A PARTICULAR PURPOSE, SHALL BE LIMITED IN DURATION TO THE WARRANTY PERIOD, AND THE REMEDIES AVAILABLE FOR BREACH THEREOF SHALL BE LIMITED TO THE REMEDIES AVAILABLE UNDER THIS EXPRESS LIMITED WARRANTY. SOME STATES DO NOT ALLOW LIMITATIONS ON HOW LONG AN IMPLIED WARRANTY LASTS, SO THE ABOVE LIMITATION MAY NOT APPLY TO YOU. IN NO EVENT SHALL FIMCO, IND.'S LIABILITY UNDER THIS LIMITED WARRANTY EXCEED THE ACTUAL AMOUNT PAID BY YOU FOR THE DEFECTIVE EQUIPMENT, NOR SHALL FIMCO, IND. BE LIABLE, UNDER ANY CIRCUMSTANCES, FOR ANY CONSEQUENTIAL, INCIDENTAL, SPECIAL OR PUNITIVE DAMAGES OR LOSSES, WHETHER DIRECT OR INDIRECT. SOME STATES DO NOT ALLOW THE EXCLUSION OR LIMITATION OF INCIDENTAL OR CONSEQUENTIAL DAMAGES, SO THE ABOVE LIMITATION OR EXCLUSION MAY NOT APPLY TO YOU.