

AXWG01 / AXWG03 WALL SYSTEM SPECIFICATION SHEET

MAX WEIGHT PER SHELF 25 LBS / 9.331 KG
MAX TOTAL WEIGHT 75 LBS / 27.993 KG
SIDE TO SIDE ROTATION 35°

**VANTAGE
POINT**
Possibilities are mounting.™

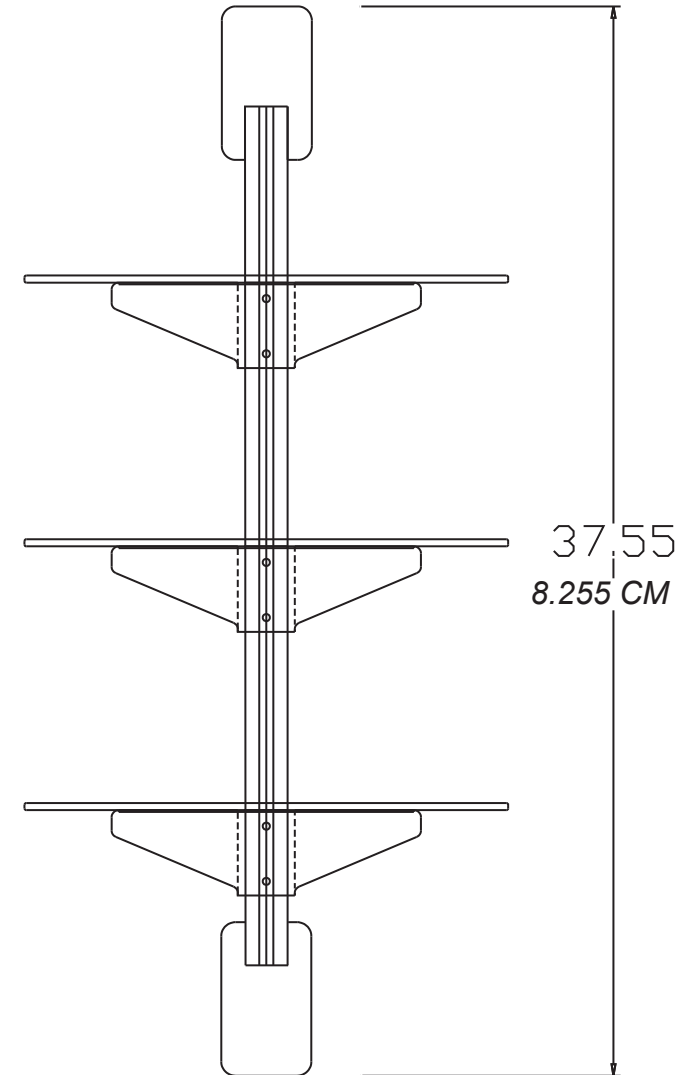
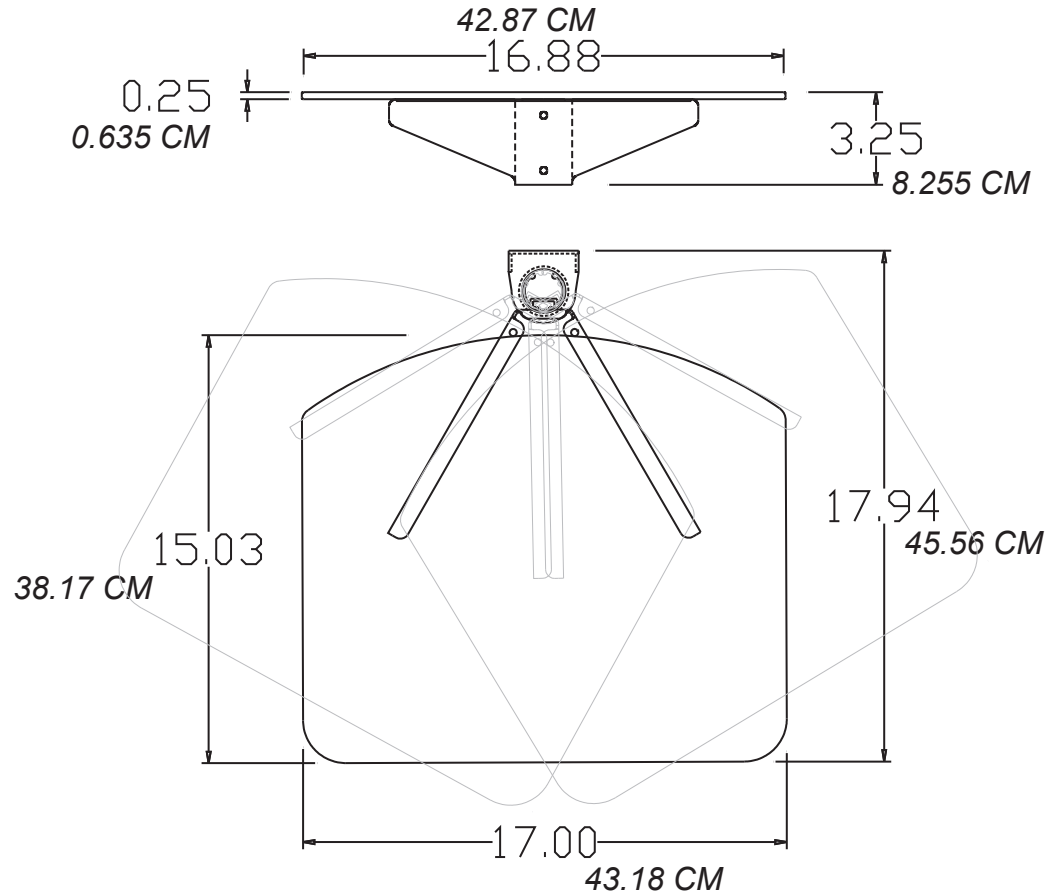

Vantage Point Products Corp. 10233 Palm Drive Santa Fe Springs, CA 90670
USA: 800.582.9595 Canada: 905.607.9994 Europe: 31.72.581.6056
Email: cons-serv@vanptc.com WebSite: www.vanptc.com