

Model: _____ Size: _____ Tag: _____

Project Name: _____

Project Location: _____

Engineer: _____ Contractor: _____

Distributor: _____ Representative: _____

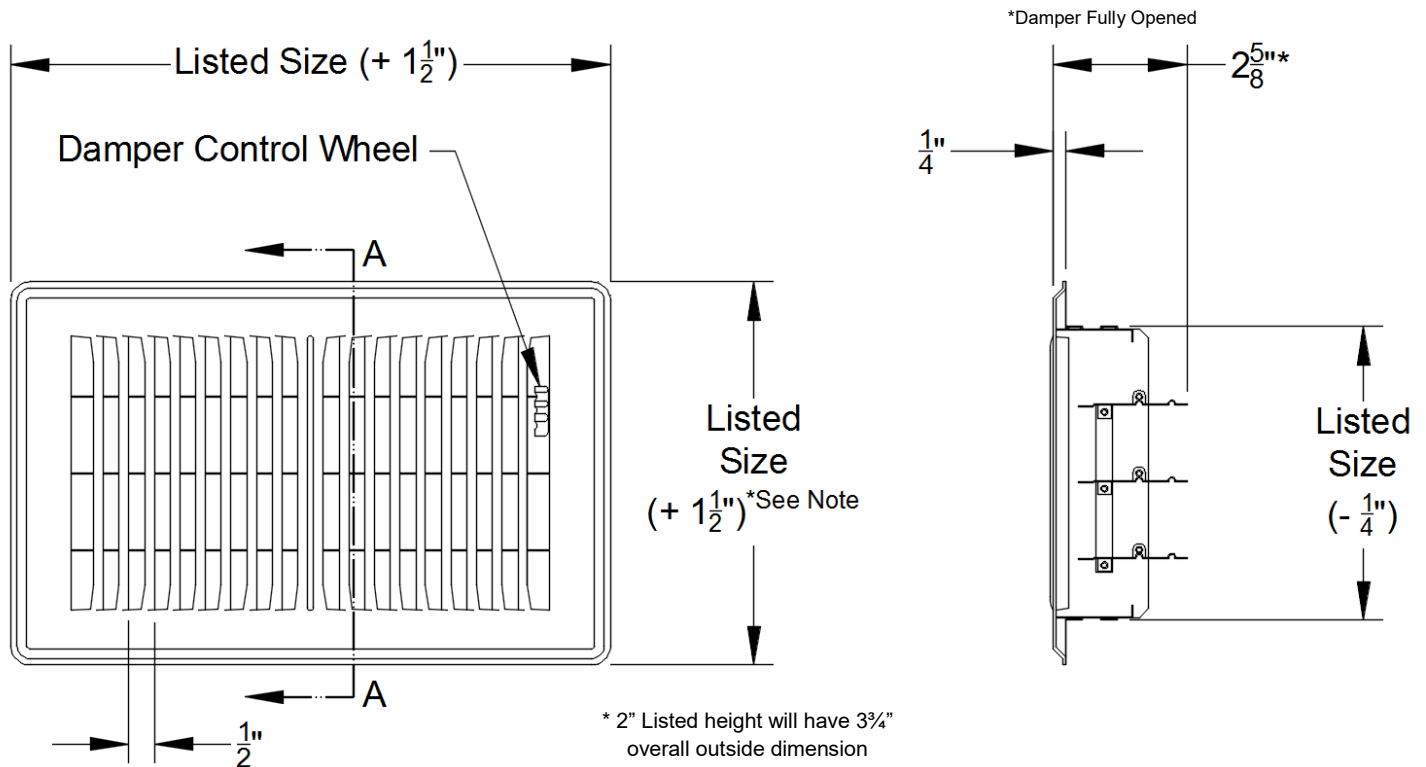

Features:

- Heavy Duty Construction
- One Piece Frame
- SmoothGlide™ Multi-Shutter Damper
- Foot Operated Wheel Control

Finish Options:

- Pristine White Powder Coat Finish
- Textured Non-Scuff Brown Powder Coat Finish
- Textured Non-Scuff Pristine White Powder Coat Finish

Note: This submittal is meant to demonstrate the general dimensions of this product. The illustrations are not meant to detail every aspect of the product. Drawings are not to scale. T.A. Industries, Inc. reserves the right to make changes without notice or obligations.