

# TIGER BRAND™

JACK POST

Put the load on us.



# THE BEST, MADE BETTER STILL.

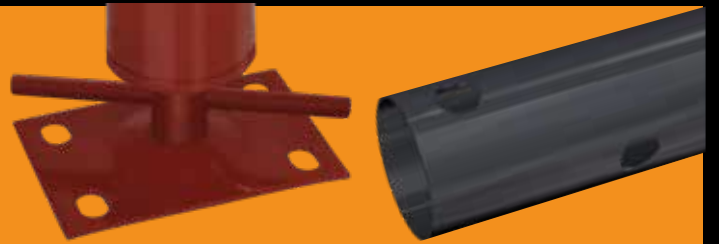

**PRECISION MANUFACTURING**



**INNOVATIVE ENGINEERING SOLUTIONS**



**VERTICALLY INTEGRATED TUBE MILL**

**Since 1946 as America's leading manufacturer of adjustable columns, posts and jacks, we've learned one indelible truth: our business isn't simply about supporting floors, beams or joists – It's also about supporting you.**

The performance of our products are superior in every respect; they are not simply manufactured, but engineered in the most sophisticated design, process automation and testing facilities in the industry. Powder coated for ultimate protection and "green by design." And constantly refined for strength, with greater structural integrity and thicker plates. Our evolving specifications say it all.

And we don't simply sell those products. We surround them with equally advanced marketing, merchandising, service and support. Our vertically integrated tube mills assure the most consistent quality and supply chain dependability, so product by product, feature for feature, The Tiger Brand Company can deliver the reliability and innovation that builds sales, profitability and long-term customer satisfaction.

**TIGER  
BRAND**  
JACK POST



**PROCESS AUTOMATION**

Our adjustable columns are compliant with ICC-ES report number 1766 as well as, IRC and IBC building codes.

# PRO SERIES JACK POST

**OUR STRONGEST JACK FOR SECURE TEMPORARY SUPPORT UNDER THE HEAVIEST LOAD AREAS.**



**Compression Load Range\*  
38,000 lbs.  
to 20,000 lbs.**

**Double Carriage Bolt & Nut for added safety**

**Adjusting Screw SAE**

**Heavy Gauge Steel Plate**

- 11 gauge inside/outside high carbon steel tubes
- Heavy gauge steel plates
- Double carriage bolt design for added safety
- Corrosion resistant coating inside & out
- Zinc-coated secure bolt/nut connectors
- Adjustment range from 4' 8" to 8' 4"
- Temporary support for room additions & remodeling projects, with the strength to support large appliances
- Easy to adjust, easy to install
- Can be used permanently as secondary support along with the approved primary support



**Designed for heavy load areas, with added strength in every component.**

## PRO SERIES JACK POST

2<sup>7</sup>/<sub>8</sub>" OD Outside Tube, 2<sup>1</sup>/<sub>2</sub>" OD Inside Tube; 3<sup>1</sup>/<sub>16</sub>" x 4" x 6" Plates

11 GA.	ADJUSTMENT RANGE	UPC	COMPRESSION LOAD RANGE*	WEIGHT	UNIT CUBE
J-PRO-100	4' 8" - 8' 4" / 56"-100"	8-38956-00100-6	38,000 lbs. to 20,000 lbs.	31 lbs.	0.5

\*Compression load is testing to the point of failure. Maximum loads are obtained at minimum extension. To determine safe or allowable loads, consult a licensed engineer.

# SUPER "S" SERIES JACK POST

ADVANCED FEATURES  
SET THE STANDARD FOR  
TEMPORARY SUPPORT

*Easy to adjust, easy to install, incredibly adaptable temporary support while mending, replacing or installing primary structural supports.*

**Jacks can be used as temporary support while making structural repairs.**

- Designed with multiple features for added safety
- Can be used permanently as secondary support (example: sagging floors)

## SUPER "SERIES" JACK POSTS 2 1/2" OD Outside Tube, 2 1/4" OD Inside Tube; 3/32" x 4" x 5" Plates

15 GA.	ADJUSTMENT RANGE	UPC	COMPRESSION LOAD RANGE*	WEIGHT	UNIT CUBE
J-S-100	4' 8" - 8' 4" / 56"-100"	8-38956-00000-9	18,000 lbs. to 9,100 lbs.	18 lbs.	0.5
J-S-93	4' 6" - 7' 9" / 54"-93"	8-38956-00093-1	18,000 lbs. to 11,350 lbs.	16 lbs.	0.4
J-S-55	2' 10" - 4' 7" / 34"-55"	8-38956-00055-9	18,000 lbs. to 14,000 lbs.	11 lbs.	0.3
J-S-36	1' 7" - 3' / 19"-36"	8-38956-00036-8	18,000 lbs. to 16,000 lbs.	8 lbs.	0.2
J-S-15	1' 0" - 1' 3" / 12"-15"	8-38956-00015-3	18,000 lbs.	4 lbs.	0.1

\*Compression load is testing to the point of failure. Maximum loads are obtained at minimum extension. To determine safe or allowable loads, consult a licensed engineer.

# JACK POST

**ALL STEEL  
ADJUSTABLE  
EASY TO INSTALL**



### Ideal temporary support for:

- Room additions
- Porches and decks
- Remodeling projects
- Sagging floors
- Under stairs
- Attics
- Basement beams
- Under kitchen areas with granite counters & heavy appliances

Note: Jack Posts are for use in projects as temporary or additional support. Not intended for permanent, primary support. Our jacks are tools that can be used to make remodeling and repair projects easier and achieve a more professional result.



### JACK POST DISPLAY/ASSORTMENT – JRD06T

(Includes products below + Display Rack)

MODEL#	ADJUSTMENT	THICKNESS	UPC	QTY.
J-PRO-100	4' 8" - 8' 4"	11 Gauge	8-38956-00100-6	4
J-S-100	4' 8" to 8' 4"	15 Gauge	8-38956-00000-9	4
J-S-93	4' 6" to 7' 9"	15 Gauge	8-38956-00093-1	4
J-S-55	2' 10" to 4' 7"	15 Gauge	8-38956-00055-9	4
J-S-36	1' 7" to 3' 0"	15 Gauge	8-38956-00036-8	4
Display Merchandiser				1

# JACK POST

## INSTALLATION INSTRUCTIONS

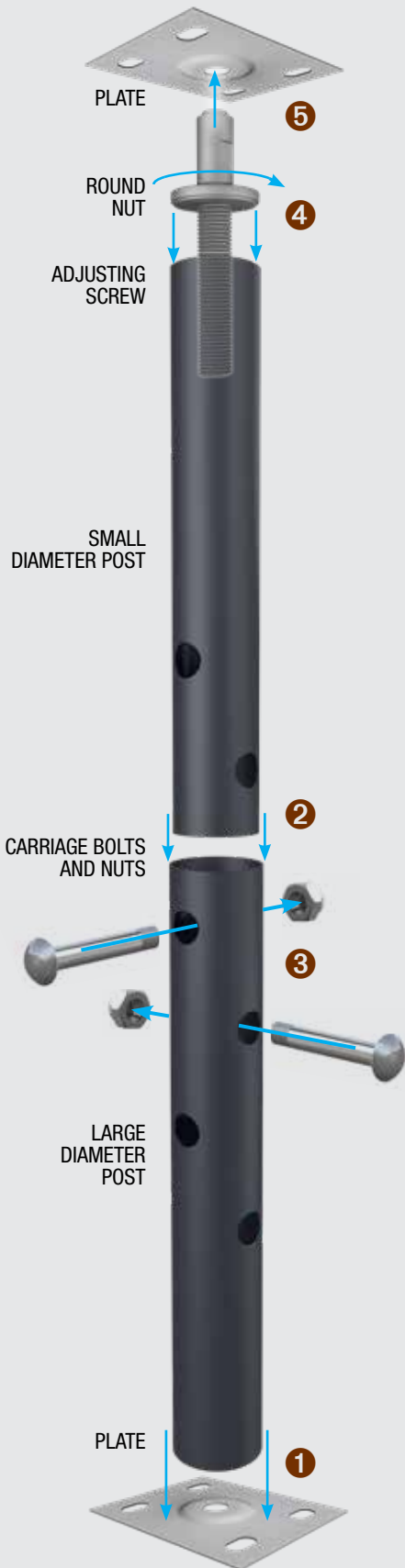

1. Place the flat side of one of the plates on footing. Put the larger diameter post over the plate with the holes oriented at the top (Figure 1). Reverse for shorter applications. For 12"-15" Jack skip steps 2 and 3.
2. Insert the smaller diameter post inside the larger diameter post. The hole end of the smaller diameter tube is required to be inserted into the outer diameter tube (Figure 2).
  - a. Note: For shorter heights, the holes of the larger diameter tube will be at the bottom (i.e. near the footer).
3. Lift the smaller diameter post to provide the tallest assembly height achievable for the given conditions. With the holes aligned between the outside and inside tube, install two carriage bolts through the aligned holes and install the acorn nuts onto the threaded portion of the carriage bolts (Figure 3).
  - a. Note: It is imperative that both carriage bolts are installed through the holes of the inside and outside tubing.
4. With the adjusting screw and nut, turn the round nut to the top of the threads of the adjusting screw. Place the adjustment screw on top of the smaller diameter post. The tapered side of the nut will fit into the smaller diameter post with the shoulder of the nut resting on top of the post (Figure 4).
  - a. Note: If the assembly was installed too high, it may prevent the installation of the adjusting nut and screw. If this is the case, go back to step 3 and readjust the assembly.
5. Place the other plate on top of the adjusting screw with the flat side of the plate facing up and use an adjustable wrench to complete the fine adjustment (Figure 5).

Note:

- For best support under wooden structures place the larger diameter tube and plate up against the wooden support (Figure 6)
- Make sure post is centered under beam and is vertically plumb (straight)
- Secure plates with proper nails, screws or bolts.
- To correct sagging floors, place beam under joists and hold in place with two Telescoping Jacks. Adjust the floor jacks one-half turn each week over several weeks.
- Telescoping jacks should be used as additional support, not the primary means of support.
- When used in a lifting application consult a licensed engineer to determine safe allowable load.
- Be sure that the jack is placed on a solid stable foundation.



# JACK POST

## INSTRUCCIONES DE INSTALACIÓN

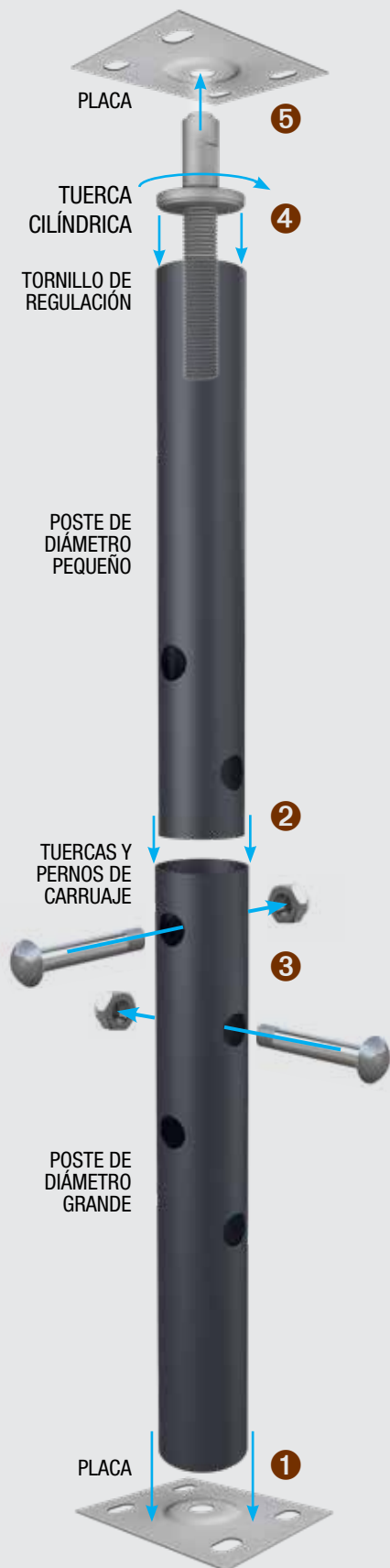

**1.** Coloque la cara plana de una de las placas sobre la base. Coloque el poste de mayor diámetro sobre la placa, con los orificios en la parte superior (**Figura 1**). Invierta para aplicaciones más cortas. Para soportes de 12 in a 15 in, saltee los pasos 2 y 3.

**2.** Introduzca el poste de menor diámetro dentro del poste de mayor diámetro. El extremo del tubo de menor diámetro que tiene orificios debe introducirse en el tubo de diámetro externo (**Figura 2**).

a. Nota: para alturas menores, los orificios del tubo de mayor diámetro estarán en la parte inferior (es decir, cerca de la base).

**3.** Levante el poste de menor diámetro hasta alcanzar la máxima altura de montaje posible para las condiciones dadas. Con los orificios de los tubos externo e interno alineados, instale dos pernos de carruaje en los orificios alineados e instale las tuercas ciegas en la parte roscada de los pernos de carruaje (**Figura 3**).

a. Nota: es imprescindible que ambos pernos de carruaje se instalen a través de los orificios de los tubos interno y externo.

**4.** Con el tornillo y la tuerca de regulación, gire la tuerca cilíndrica hasta llegar a la parte superior de la rosca del tornillo de regulación. Coloque el tornillo de regulación en la parte superior del poste de menor diámetro. El lado ahusado de la tuerca encajará en el poste de menor diámetro, y el reborde de la tuerca quedará apoyado sobre la parte superior del poste (**Figura 4**).

a. Nota: Si el montaje se instaló a demasiada altura, esto podría impedir la instalación del tornillo y la tuerca de regulación. En este caso, vuelva al paso 3 y reajuste el montaje.

**5.** Coloque la otra placa sobre el tornillo de regulación, con la cara plana de la placa hacia arriba, y utilice una llave inglesa para completar el ajuste fino (**Figura 5**).

Nota:

- Para obtener el mejor soporte posible bajo estructuras de madera, coloque el tubo de mayor diámetro y la placa contra el soporte de madera (**Figura 6**)
- Asegúrese de que el poste esté centrado bajo la viga y que esté verticalmente a plomo (recto).
- Asegure las placas con los clavos, tornillos o pernos correspondientes.
- Para corregir pisos hundidos, coloque una viga debajo de los tirantes y sosténgala en su lugar con dos soportes telescópicos. Ajuste los soportes de piso media vuelta cada semana durante varias semanas.
- Los soportes telescópicos deben utilizarse como apoyo adicional, no como medio principal de apoyo.
- Cuando se los utilice en una aplicación de elevación, debe consultarse a un ingeniero calificado para determinar la carga permitida segura.
- Asegúrese de que el gato esté colocado sobre una base sólida y estable.



# JACK POST

## INSTRUCTIONS D'INSTALLATION

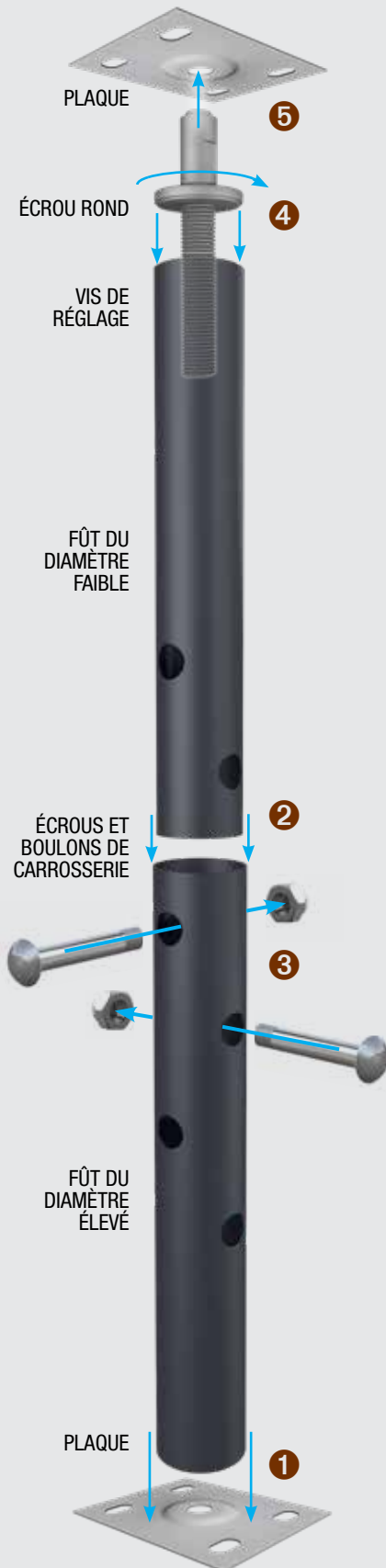

1. Placez le côté plat d'une des plaques sur le sol. Placez le fût du diamètre le plus élevé sur la plaque avec les trous orientés vers le haut (**Figure 1**). Inversez pour les applications plus courtes. Pour les étais de 30 à 38 cm (12 à 15 po) passez les étapes 2 et 3.
2. Insérez le fût du diamètre le plus faible dans le fût du diamètre le plus élevé. Le trou d'extrémité du tube du diamètre le plus faible doit être inséré dans le tube de diamètre extérieur (**Figure 2**).
  - a. Remarque : pour les plus petites hauteurs, les trous du tube du diamètre le plus élevé seront en bas (près de la base).
3. Soulevez le fût du diamètre le plus faible pour obtenir la hauteur la plus grande pouvant être obtenue pour les conditions données. Alignez les trous des tubes extérieur et intérieur. Insérez deux boulons de carrosserie dans l'alignement des trous et placez les écrous borgnes sur la portion fileté des boulons (**Figure 3**).
  - a. Remarque : il est impératif d'insérer les deux boulons de carrosserie dans les trous des tubes intérieur et extérieur.
4. À l'aide de la vis et de l'écrou de réglage, faites tourner l'écrou rond vers le haut du filetage de la vis de réglage. Placez la vis de réglage en haut du fût du diamètre le plus petit. La partie conique de l'écrou s'insère dans le fût du diamètre le plus petit, l'épaulement de l'écrou reposant sur le haut du fût (**Figure 4**).
  - a. Remarque : une installation trop élevée de l'ensemble peut empêcher l'installation de la vis et de l'écrou de réglage. Dans ce cas, revenez à l'étape 3 et réajustez l'ensemble.
5. Placez l'autre plaque au-dessus de la vis de réglage, le côté plat de la plaque vers le haut, et utilisez une clé à molette pour affiner le réglage (**Figure 5**).

Remarque :

- Pour un meilleur soutien sous les structures en bois, placez le tube du plus grand diamètre et la plaque contre le support en bois (**Figure 6**)
- Veillez à ce que le fût soit centré sous la poutre et vertical (droit)
- Sécurisez les plaques de manière appropriée avec des clous, des vis ou des chevilles.
- Pour corriger des planchers affaissés, placez une poutre sous les solives et maintenez l'ensemble en place avec deux étais télescopiques. Ajustez les étais d'un demi-tour chaque semaine pendant plusieurs semaines.
- Les étais télescopiques ne doivent servir que pour un soutien supplémentaire, en aucun cas pour le soutien principal.
- Pour une utilisation dans une application de soulèvement, consultez un ingénieur qualifié pour déterminer la charge maximale autorisée.
- Assurez-vous que le cric est placé sur une base solide et stable.





# TEMPORARY SHORE JACK

## TEMPORARY SHORING SUPPORT

The Shore Jack™ offers a convenient and durable way to make structural repairs and functions as temporary support for various construction and remodeling projects.

- Transforms a nominal 4 x 4 lumber into a versatile adjustable post
- Recommended as a temporary or non-primary support.
- Load capacity dependent on a 4 x 4 used up to 24,700 lbs.
- Consult with your wood supplier for allowable load
- 4" height adjustment creates an adjustable post

### USE FOR:

- Construction projects
- Repairs or installations
- Renovations
- Sagging floors
- Crawl spaces

Use a 4" x 4" wood post and cut to desired length.

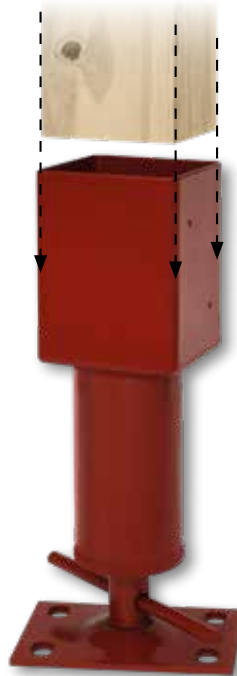

### TEMPORARY SHORING JACK

MODEL#	ADJUSTMENT RANGE	UPC
S301944PC	4"	890475001301

Fits a 4" x 4" timber post (3.75" x 3.75" ID), height fully retracted: 14 5/16", 4" screw adjustment fully extended equals overall height at 18 5/16"

# ADJUST-A-STUD

**PUT REAL VERSATILITY  
IN YOUR TOOLBAG WITH  
ADJUST-A-STUD™!**

## FULL FRAME DUST CONTROL BARRIER:



- Home remodeling
- Interior demolition
- Drywall/plaster sanding
- Temporary partition walls
- Mold remediation
- Lead paint/asbestos removal
- Commercial/industrial applications

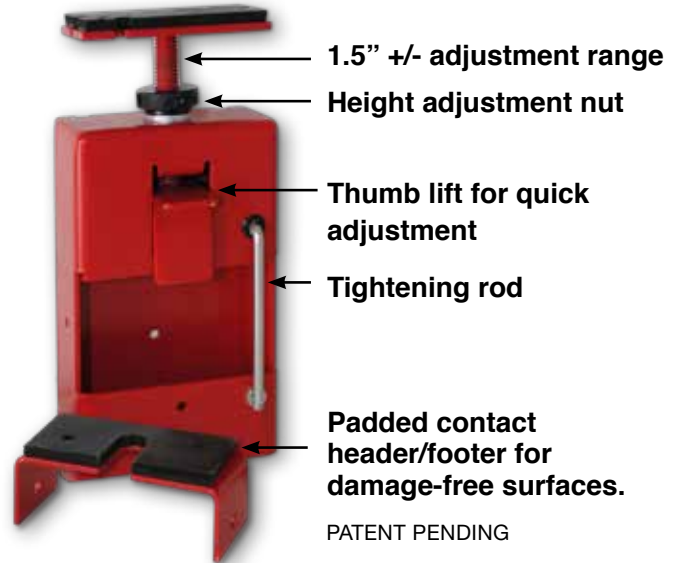

## JUST CUT A 2X4, SLIP ON ADJUST-A-STUD™ AND KEEP ON WORKING!

### TEMPORARY SUPPORT FOR:



**Bracing**



**Extra Set of Hands**



**Temporary Jacks**



**Barricades**



**Clamping**

- Temporary support
- Temporary expanding clamps & bracing
- Barricades
- Temporary walls
- Cargo control
- All-purpose "extra hand"

**Trucks and Vans – create custom bracing for cargo control.**



### ADJUST-A-STUD

MODEL#	UPC
J ADJUSTUD	890475001004

Load values of this system are strictly dependent upon the load capabilities of the wood 2x4 used. Consult your lumber dealer for load capabilities of the specific wood product used in your project.

# MOBILE HOME JACKS

## MOBILE HOME AND RV STABILIZATION



### State-of-the-art multi-purpose jacks:

- Perfect for stabilizing RV and other trailers when parked
- Easy to store, easy to install, easy to adjust from 12" to 16"

### MOBILE HOME JACKS

11 GA.	ADJUSTMENT RANGE	UPC	ALLOWABLE LOAD	WEIGHT	UNIT CUBE
J-MOBILE	1' - 1' 4" / 12" - 16"	838956000016	24,700	9 lbs.	0.5

Available in both Standard Series and H Plates

# ADJUSTABLE BUILDING COLUMNS

ULTIMATE STRENGTH, ULTIMATE EFFICIENCY FOR PERMANENT NEW HOME CONSTRUCTION AND REMODELING SUPPORT.

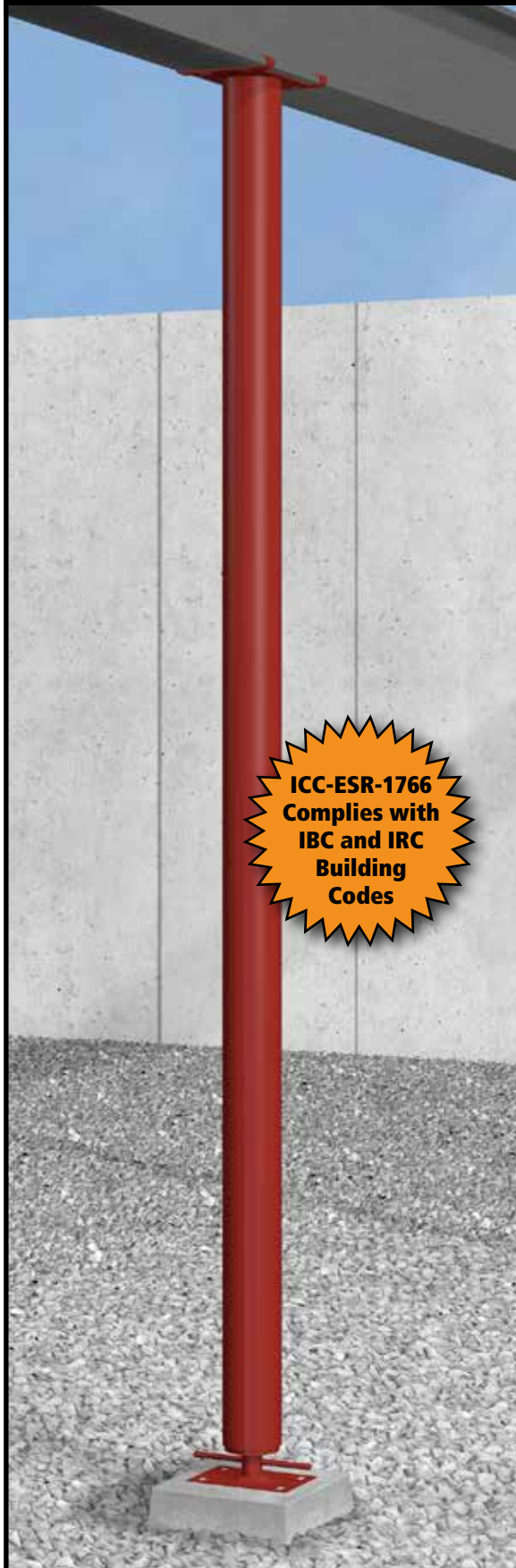

**ICC-ESR-1766  
Complies with  
IBC and IRC  
Building  
Codes**

- Adjustable building columns can be installed in about fifteen minutes by a single worker
- Set column perpendicular between footer and beam with adjustment screw on footer; adjust screw until post is firmly in position
- Additional adjustments may be made during construction to maintain level floor
- Tamper proof adjustment... **poured concrete floor locks column adjustment permanently** when correctly installed
- 11 gauge Adjustable building columns available in 3", 3 1/2", 4" OD, and 3 1/2" OD Schedule 40
- Corrosion resistant powder coating that exceeds ASTM-B117-85
- Lengths available in 3" increments up to 12 feet
- Fully assembled, self-contained, no loose parts
- Refer to current ICC-ES report for load values

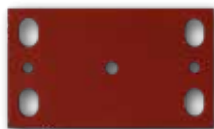

## STANDARD END PLATE

USED WITH WOOD BEAMS  
4 1/4" x 7 1/2" x .205" thick

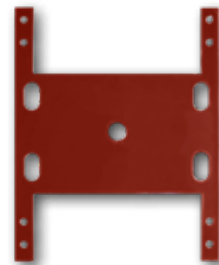

## "H" PLATE

USED WITH STEEL BEAMS  
4 1/4" x 7 1/4" x .205" thick

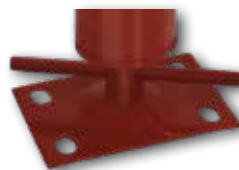

## SWIVEL END PLATE

4" x 6" x .205" thick

**SCREW:** 1 1/4" O.D., 7 Pitch  
"V" thread with 4" adjustment

**NUT:** 3" O.D. tapped for 1 1/4" 7 pitch thread

# ADJUSTABLE BUILDING COLUMNS

3" O.D., 11 GAUGE STEEL TUBING							
MODEL#	ADJUSTMENT RANGE	UPC STANDARD SERIES	ALLOWABLE STRENGTH LOAD LBS. (ASD)*	DESIGN STRENGTH LOAD LBS. (LRFD)*	WEIGHT UNIT	UNIT CUBE	
3A-6064	6' - 6' 4"	72" - 76"	8-38956-00376-5	13,500	20,300	28 lbs.	1.37
3A-6367	6' 3" - 6' 7"	75" - 79"	8-38956-00379-6	13,300	19,900	29 lbs.	1.42
3A-66610	6' 6" - 6' 10"	78" - 82"	8-38956-00382-6	13,000	19,500	30 lbs.	1.48
3A-6971	6' 9" - 7' 1"	81" - 85"	8-38956-00385-7	12,700	19,100	31 lbs.	1.53
3A-7074	7' - 7' 4"	84" - 88"	8-38956-00388-8	12,400	18,600	32 lbs.	1.57
3A-7377	7' 3" - 7' 7"	87" - 91"	8-38956-00391-8	12,100	18,200	33 lbs.	1.64
3A-76710	7' 6" - 7' 10"	90" - 94"	8-38956-00394-9	11,800	17,700	34 lbs.	1.70
3A-7981	7' 9" - 8' 1"	93" - 97"	8-38956-00397-0	11,500	17,300	35 lbs.	1.75
3A-8084	8' - 8' 4"	96" - 100"	8-38956-00300-0	11,200	16,800	35 lbs.	1.81
3A-8387	8' 3" - 8' 7"	99" - 103"	8-38956-00303-1	10,900	16,300	36 lbs.	1.86
3A-86810	8' 6" - 8' 10"	102" - 106"	8-38956-00306-2	10,600	15,900	37 lbs.	1.92
3A-8991	8' 9" - 9' 1"	105" - 109"	8-38956-00309-3	10,200	15,400	38 lbs.	1.97
3A-9094	9' - 9' 4"	108" - 112"	8-38956-00312-3	9,900	14,900	39 lbs.	2.03
3A-9397	9' 3" - 9' 7"	111" - 115"	8-38956-00315-4	9,600	14,400	40 lbs.	2.08
3A-96910	9' 6" - 9' 10"	114" - 118"	8-38956-00318-5	9,300	14,000	41 lbs.	2.14
3A-99101	9' 9" - 10' 1"	117" - 121"	8-38956-00321-5	9,000	13,500	42 lbs.	2.20
3A-100104	10' - 10' 4"	120" - 124"	8-38956-00324-6	8,700	13,000	43 lbs.	2.25
3A-103107	10' 3" - 10' 7"	123" - 127"	8-38956-00325-3	8,300	12,500	47 lbs.	2.31
3A-1061010	10' 6" - 10' 10"	126" - 130"	8-38956-00326-0	8,000	12,100	49 lbs.	2.36
3A-109111	10' 9" - 11' 1"	129" - 133"	8-38956-00327-7	7,700	11,600	50 lbs.	2.42
3A-110114	11' - 11' 4"	132" - 136"	8-38956-00328-4	7,400	11,100	51 lbs.	2.47
3A-113117	11' 3" - 11' 7"	135" - 139"	8-38956-00329-1	7,100	10,700	52 lbs.	2.53
3A-1161110	11' 6" - 11' 10"	138" - 142"	8-38956-00330-7	6,800	10,200	53 lbs.	2.58
3A-119121	11' 9" - 12' 1"	141" - 145"	8-38956-00331-4	6,600	10,000	54 lbs.	2.64

3½" O.D., 11 GAUGE STEEL TUBING							
MODEL#	ADJUSTMENT RANGE	UPC STANDARD SERIES	ALLOWABLE STRENGTH LOAD LBS. (ASD)*	DESIGN STRENGTH LOAD LBS. (LRFD)*	WEIGHT UNIT	UNIT CUBE	
35A-6064	6' - 6' 4"	72" - 76"	8-38956-35160-6	17,000	25,600	33 lbs.	1.37
35A-6367	6' 3" - 6' 7"	75" - 79"	8-38956-35163-7	16,800	25,200	34 lbs.	1.42
35A-66610	6' 6" - 6' 10"	78" - 82"	8-38956-35166-8	16,500	24,800	35 lbs.	1.48
35A-6971	6' 9" - 7' 1"	81" - 85"	8-38956-35169-9	16,300	24,500	36 lbs.	1.53
35A-7074	7' - 7' 4"	84" - 88"	8-38956-35170-5	16,000	24,100	37 lbs.	1.59
35A-7377	7' 3" - 7' 7"	87" - 91"	8-38956-35173-6	15,700	23,600	38 lbs.	1.64
35A-76710	7' 6" - 7' 10"	90" - 94"	8-38956-35176-7	15,500	23,200	39 lbs.	1.70
35A-7981	7' 9" - 8' 1"	93" - 97"	8-38956-35179-8	15,200	22,800	40 lbs.	1.75
35A-8084	8' - 8' 4"	96" - 100"	8-38956-35180-4	14,900	22,400	41 lbs.	1.81
35A-8387	8' 3" - 8' 7"	99" - 103"	8-38956-35183-5	14,600	21,900	42 lbs.	1.86
35A-86810	8' 6" - 8' 10"	102" - 106"	8-38956-35186-6	14,300	21,500	44 lbs.	1.92
35A-8991	8' 9" - 9' 1"	105" - 109"	8-38956-35189-7	14,000	21,000	45 lbs.	1.97
35A-9094	9' - 9' 4"	108" - 112"	8-38956-35190-3	13,700	20,600	46 lbs.	2.03
35A-9397	9' 3" - 9' 7"	111" - 115"	8-38956-35193-4	13,400	20,100	47 lbs.	2.08
35A-96910	9' 6" - 9' 10"	114" - 118"	8-38956-35196-5	13,100	19,600	48 lbs.	2.14
35A-99101	9' 9" - 10' 1"	117" - 121"	8-38956-35199-6	12,800	19,200	49 lbs.	2.20
35A-100104	10' - 10' 4"	120" - 124"	8-38956-35110-1	12,400	18,700	50 lbs.	2.25
35A-103107	10' 3" - 10' 7"	123" - 127"	8-38956-35111-8	12,100	18,200	52 lbs.	2.31
35A-1061010	10' 6" - 10' 10"	126" - 130"	8-38956-00652-0	11,800	17,700	52 lbs.	2.36
35A-109111	10' 9" - 11' 1"	129" - 133"	8-38956-00653-7	11,500	17,300	52 lbs.	2.42
35A-110114	11' - 11' 4"	132" - 136"	8-38956-35114-9	11,200	16,800	53 lbs.	2.47
35A-113117	11' 3" - 11' 7"	135" - 139"	8-38956-00655-1	10,800	16,300	54 lbs.	2.53
35A-1161110	11' 6" - 11' 10"	138" - 142"	8-38956-00656-8	10,500	15,800	55 lbs.	2.58
35A-119121	11' 9" - 12' 1"	141" - 145"	8-38956-35117-0	10,200	15,400	56 lbs.	2.64

\*Consult a registered professional engineer for column selection based on ASD or LRFD methodologies.

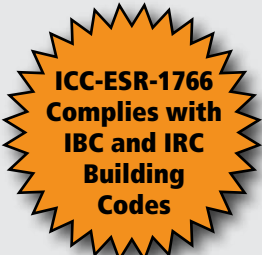

- Minimum yield strength of 42,000 psi. complies with ASTM A500.
- Meets all FHA/HUD requirements.
- Finished with corrosion resistant coating that exceeds ASTM-B117-85. One year limited warranty.

**STANDARD END PLATE:** 4¼" x 7½" x .205"  
**"H" PLATE:** 4¼" x 7¼" x .205"  
**SWIVEL END PLATE:** 4" x 6" x .205"  
 (Please specify either Standard or H Series Plate when ordering)

# ADJUSTABLE BUILDING COLUMNS

## 4" O.D., 11 GAUGE STEEL TUBING

MODEL#	ADJUSTMENT RANGE	UPC STANDARD SERIES	ALLOWABLE STRENGTH LOAD LBS. (ASD)*	DESIGN STRENGTH LOAD LBS. (LRFD)*	WEIGHT UNIT	UNIT CUBE	
4A-6064	6' - 6' 4"	72" - 76"	8-38956-00476-2	20,400	30,700	37 lbs.	1.37
4A-6367	6' 3" - 6' 7"	75" - 79"	8-38956-00479-3	20,200	30,400	38 lbs.	1.42
4A-66610	6' 6" - 6' 10"	78" - 82"	8-38956-00482-3	20,000	30,000	40 lbs.	1.48
4A-6971	6' 9" - 7' 1"	81" - 85"	8-38956-00485-4	19,700	29,700	41 lbs.	1.53
4A-7074	7' - 7' 4"	84" - 88"	8-38956-00488-5	19,500	29,300	42 lbs.	1.59
4A-7377	7' 3" - 7' 7"	87" - 91"	8-38956-00491-5	19,300	28,900	43 lbs.	1.64
4A-76710	7' 6" - 7' 10"	90" - 94"	8-38956-00494-6	19,000	28,600	45 lbs.	1.70
4A-7981	7' 9" - 8' 1"	93" - 97"	8-38956-00497-7	18,700	28,200	46 lbs.	1.75
4A-8084	8' - 8' 4"	96" - 100"	8-38956-00400-7	18,500	27,800	47 lbs.	1.81
4A-8387	8' 3" - 8' 7"	99" - 103"	8-38956-00403-8	18,200	27,400	48 lbs.	1.86
4A-86810	8' 6" - 8' 10"	102" - 106"	8-38956-00406-9	17,900	26,900	50 lbs.	1.92
4A-8991	8' 9" - 9' 1"	105" - 109"	8-38956-00409-0	17,600	26,500	51 lbs.	1.97
4A-9094	9' - 9' 4"	108" - 112"	8-38956-00412-0	17,400	26,100	52 lbs.	2.03
4A-9397	9' 3" - 9' 7"	111" - 115"	8-38956-00415-1	17,100	25,700	53 lbs.	2.08
4A-96910	9' 6" - 9' 10"	114" - 118"	8-38956-00418-2	16,800	25,200	55 lbs.	2.14
4A-99101	9' 9" - 10' 1"	117" - 121"	8-38956-00421-2	16,500	24,800	56 lbs.	2.20
4A-100104	10' - 10' 4"	120" - 124"	8-38956-00424-3	16,200	24,300	57 lbs.	2.25
4A-103107	10' 3" - 10' 7"	123" - 127"	8-38956-00425-0	15,900	23,900	58 lbs.	2.31
4A-1061010	10' 6" - 10' 10"	126" - 130"	8-38956-00427-4	15,600	23,400	60 lbs.	2.36
4A-109111	10' 9" - 11' 1"	129" - 133"	8-38956-00430-4	15,300	22,900	61 lbs.	2.42
4A-110114	11' - 11' 4"	132" - 136"	8-38956-00433-5	14,900	22,500	62 lbs.	2.47
4A-113117	11' 3" - 11' 7"	135" - 139"	8-38956-00436-6	14,600	22,000	63 lbs.	2.53
4A-1161110	11' 6" - 11' 10"	138" - 142"	8-38956-00439-7	14,300	21,500	64 lbs.	2.58
4A-119121	11' 9" - 12' 1"	141" - 145"	8-38956-00441-0	14,000	21,000	66 lbs.	2.64

## 3½" O.D., SCHEDULE 40 SERIES

MODEL#	ADJUSTMENT RANGE	UPC STANDARD SERIES	ALLOWABLE STRENGTH LOAD LBS. (ASD)*	DESIGN STRENGTH LOAD LBS. (LRFD)*	WEIGHT UNIT	UNIT CUBE	
3540A-6064	6' - 6' 4"	72" - 76"	8-38956-40160-8	29,300	44,000	52 lbs.	1.37
3540A-6367	6' 3" - 6' 7"	75" - 79"	8-38956-40161-4	28,800	43,300	54 lbs.	1.42
3540A-66610	6' 6" - 6' 10"	78" - 82"	8-38956-40162-2	28,400	42,600	56 lbs.	1.48
3540A-6971	6' 9" - 7' 1"	81" - 85"	8-38956-40163-9	27,900	41,900	58 lbs.	1.53
3540A-7074	7' - 7' 4"	84" - 88"	8-38956-40164-6	27,400	41,200	60 lbs.	1.59
3540A-7377	7' 3" - 7' 7"	87" - 91"	8-38956-40165-3	26,900	40,500	62 lbs.	1.64
3540A-76710	7' 6" - 7' 10"	90" - 94"	8-38956-40166-0	26,400	39,700	64 lbs.	1.70
3540A-7981	7' 9" - 8' 1"	93" - 97"	8-38956-40167-7	25,900	39,000	65 lbs.	1.75
3540A-8084	8' - 8' 4"	96" - 100"	8-38956-40168-4	25,400	38,200	67 lbs.	1.81
3540A-8387	8' 3" - 8' 7"	99" - 103"	8-38956-40169-1	24,900	37,400	69 lbs.	1.86
3540A-86810	8' 6" - 8' 10"	102" - 106"	8-38956-40170-7	24,400	36,600	71 lbs.	1.92
3540A-8991	8' 9" - 9' 1"	105" - 109"	8-38956-40171-4	23,800	35,800	73 lbs.	1.97
3540A-9094	9' - 9' 4"	108" - 112"	8-38956-40172-1	23,300	35,000	75 lbs.	2.03
3540A-9397	9' 3" - 9' 7"	111" - 115"	8-38956-40173-8	22,700	34,100	77 lbs.	2.08
3540A-96910	9' 6" - 9' 10"	114" - 118"	8-38956-40174-5	22,200	33,300	79 lbs.	2.14
3540A-99101	9' 9" - 10' 1"	117" - 121"	8-38956-40175-2	21,600	32,500	81 lbs.	2.20
3540A-100104	10' - 10' 4"	120" - 124"	8-38956-40176-9	21,000	31,600	83 lbs.	2.25
3540A-103107	10' 3" - 10' 7"	123" - 127"	8-38956-40177-6	20,500	30,800	85 lbs.	2.31
3540A-1061010	10' 6" - 10' 10"	126" - 130"	8-38956-40178-3	19,900	29,900	87 lbs.	2.36
3540A-109111	10' 9" - 11' 1"	129" - 133"	8-38956-40179-0	19,300	29,100	89 lbs.	2.42
3540A-110114	11' - 11' 4"	132" - 136"	8-38956-40180-6	18,800	28,200	90 lbs.	2.47
3540A-113117	11' 3" - 11' 7"	135" - 139"	8-38956-00609-4	18,200	27,400	92 lbs.	2.53
3540A-1161110	11' 6" - 11' 10"	138" - 142"	8-38956-40182-0	17,600	26,500	94 lbs.	2.58
3540A-119121	11' 9" - 12' 1"	141" - 145"	8-38956-40183-7	17,100	25,700	96 lbs.	2.64

\*Consult a registered professional engineer for column selection based on ASD or LRFD methodologies.



**ICC-ESR-1766**  
Complies with  
IBC and IRC  
Building  
Codes

- Minimum yield strength of 42,000 psi. complies with ASTM A500.
- Meets all FHA/HUD requirements.
- Finished with corrosion resistant coating that exceeds ASTM-B117-85. One year limited warranty.

**STANDARD END PLATE:** 4¼" x 7½" x .205"  
**"H" PLATE:** 4¼" x 7¼" x .205"  
**SWIVEL END PLATE:** 4" x 6" x .205"  
 (Please specify either Standard or H Series Plate when ordering)

LOAD  
CARRYING  
BEAM

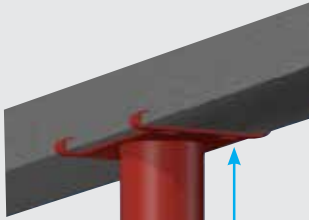

## ADJUSTABLE COLUMNS

### INSTALLATION INSTRUCTIONS

Installation Time: Approximately 15 Minutes

Tools Required: None

1. Choose the correct size and strength column for the project based on construction document.
2. Adjust screw to slightly short of the length needed between footer and load carrying beam at installation location (**Figure 1**).
3. Place column vertically between footer and beam with the adjustment nut and screw on the footer (adjustable end down) (**Figure 2**).
4. Adjust screw to wedge the column between footer and beam, tighten until Mono-Post is firmly centered directly under the load carrying beam and the footer below (**Figure 3**).
5. Additional screw adjustments may be made during construction to keep floor level
6. Poured concrete basement floor permanently locks column adjustment (**Figure 4**).

TAMPER PROOF ADJUSTMENT: COLUMN SHOULD BE POSITIONED WITH ADJUSTMENT NUT AND SCREW AT THE FOOTER.

2

3

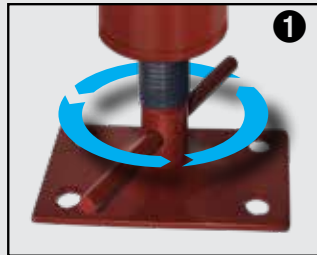

ADJUSTMENT NUT AND SCREW



FOOTER



*Note: Always consult Local Building Codes for specific installation requirements in your area.*

DE CHARGE  
FAISCEAU

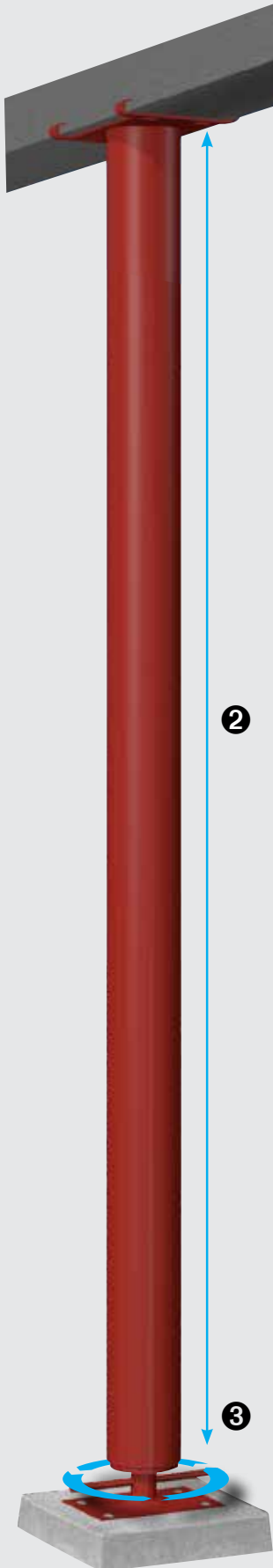

FOOTER

## ADJUSTABLE COLUMNS

### INSTRUCTIONS D'INSTALLATION

Temps d'installation : environ 15 minutes

Outils requis : aucun

1. Choisissez le poteau simple de la longueur et de la force adaptées au projet en fonction des documents de construction
2. Sur le site de l'installation, ajustez la vis pour obtenir une longueur légèrement inférieure à la longueur requise entre la base et la poutre porteuse (**Figure 1**).
3. Placez le poteau simple verticalement entre la base et la poutre, l'écrou et la vis de réglage sur la base (extrémité réglable vers le bas) (**Figure 2**).
4. Réglez la vis pour caler le poteau simple entre la base et la poutre, et resserrez jusqu'à ce que le poteau simple soit fermement centré directement sous la poutre porteuse et avec la base (**Figure 3**).
5. Il est possible d'effectuer des réglages supplémentaires de la vis pendant la construction afin de maintenir le niveau du plancher
6. Le cimentage du sol fixe de manière permanente le réglage du poteau simple (**Figure 4**).

POUR UN RÉGLAGE PROTÉGÉ CONTRE LES MANIPULATIONS : LE POTEAU SIMPLE DOIT ÊTRE POSITIONNÉ AVEC L'ÉCROU ET LA VIS DE RÉGLAGE SUR LA BASE.

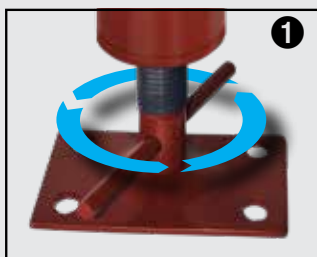

ÉCROU DE RÉGLAGE ET LA VIS



Remarque : consultez toujours le code du bâtiment local pour connaître les exigences d'installation spécifiques dans votre région.



DE  
TRANSPORTE  
DE CARGA DEL  
HAZ

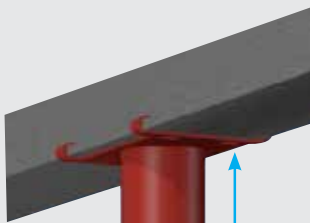

## ADJUSTABLE COLUMNS

### INSTRUCCIONES DE INSTALACIÓN

Tiempo de instalación: aproximadamente 15 minutos.

Herramientas necesarias: ninguna

1. Escoja el monoposte del tamaño y la resistencia adecuados para el proyecto en función de los documentos de construcción
2. Ajuste el tornillo a un largo ligeramente inferior a la longitud necesaria entre la base y la viga que soporta peso en el lugar de instalación (**Figure 1**).
3. Coloque el monoposte en forma vertical entre la base y la viga, con la tuerca y el tornillo de regulación sobre la base (con el extremo regulable hacia abajo) (**Figure 2**).
4. Ajuste el tornillo para encajar el monoposte entre la base y la viga, ajuste hasta que el monoposte quede firmemente centrado directamente debajo de la viga que soporta peso, con la base debajo (**Figure 3**).
5. Pueden realizarse ajustes adicionales del tornillo durante la construcción para mantener el piso nivelado.
6. El piso de cemento vertido del sótano bloquea el ajuste del monoposte (**Figure 4**).

AJUSTE INVARIABLE: EL MONOPOSTE DEBE COLOCARSE CON LA TUERCA Y EL TORNILLO DE REGULACIÓN EN LA BASE.

2

3

LA BASE



TUERCA Y EL TORNILLO DE AJUSTE



*Nota: siempre deben consultarse los códigos de construcción locales para determinar los requisitos de instalación específicos de su área.*

# MINI COLUMNS

**COMPACT PERMANENT SUPPORT  
FOR RENOVATIONS AND  
CONSTRUCTION PROJECTS.**



**State-of-the-art  
multi-purpose jacks:**

- Ideal permanent support for crawl spaces, under windows and tight confines
- Easy to store, easy to install, easy to adjust

MINI COLUMNS					
NO.	UPC	NO.	UPC	DESCRIPTION	ALLOWABLE LOAD
3A-1014	838956001013	3A-1014-2	838956001167	3" 1'0" - 1'4" Mini Column	24,700
3A-1418	838956001020	3A-1418-2	838956001174	3" 1'4" - 1'8" Mini Column	24,700
3A-1820	838956001037	3A-1820-2	838956001181	3" 1'8" - 2'0" Mini Column	24,700
3A-2024	838956001044	3A-2024-2	838956001198	3" 2'0" - 2'4" Mini Column	23,700
3A-2428	838956001051	3A-2428-2	838956001204	3" 2'4" - 2'8" Mini Column	23,700
3A-2830	838956001068	3A-2830-2	838956001211	3" 2'8" - 3'0" Mini Column	23,700
3A-3034	838956001075	3A-3034-2	838956001228	3" 3'0" - 3'4" Mini Column	22,300
3A-3438	838956001082	3A-3438-2	838956001235	3" 3'4" - 3'8" Mini Column	22,300
3A-3840	838956001099	3A-3840-2	838956001242	3" 3'8" - 4'0" Mini Column	22,300
3A-4044	838956001105	3A-4044-2	838956001259	3" 4'0" - 4'4" Mini Column	20,700
3A-4448	838956001112	3A-4448-2	838956001266	3" 4'4" - 4'8" Mini Column	20,700
3A-4850	838956001129	3A-4850-2	838956001273	3" 4'8" - 5'0" Mini Column	20,700
3A-5054	838956001136	3A-5054-2	838956001280	3" 5'0" - 5'4" Mini Column	18,800
3A-5458	838956001143	3A-5458-2	838956001297	3" 5'4" - 5'8" Mini Column	18,800
3A-5860	838956001150	3A-5860-2	838956001303	3" 5'8" - 6'0" Mini Column	18,800

Available in both Standard Series and H Plates

# FIXED LENGTH BUILDING COLUMNS

## PERMANENT SUPPORT FOR NEW HOME CONSTRUCTION

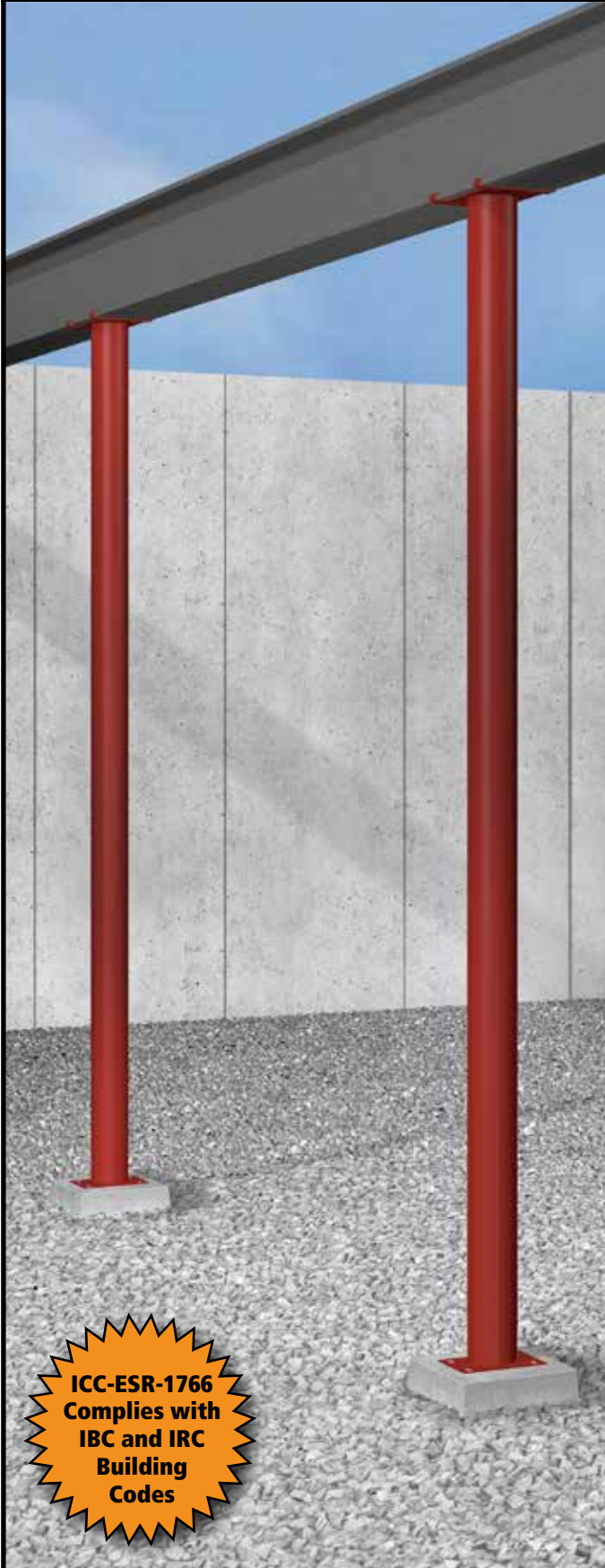

Designed for permanent building support applications, available in any length up to 12', Tiger Brand fixed length columns arrive fully assembled to your specifications and fully code compliant.

- 11 gauge COLUMNS available in 3", 3½", 4" OD and 3½" OD Schedule 40
- Corrosion resistant powder coating exceeds ASTM-B117-85
- Choose one plate welded + one plate loose, both plates welded or both plates loose
- ID labels clearly show size
- Any length - fixed length columns are available in custom lengths up to 12 feet to fit any need
- Order column length to fit. (See product list for most popular sizes).



### STANDARD END PLATE

USED WITH WOOD BEAMS  
4¼" x 7½" x .205" thick

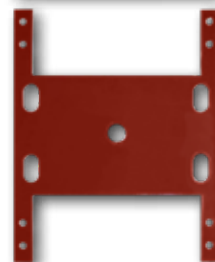

### "H" PLATE

USED WITH STEEL BEAMS  
4¼" x 7¼" x .205" thick

**ICC-ESR-1766  
Complies with  
IBC and IRC  
Building  
Codes**

## FIXED LENGTH BUILDING COLUMNS



### 3" O.D., 11 GAUGE STEEL TUBING

MODEL#	ADJUSTMENT RANGE	UPC STANDARD SERIES	ALLOWABLE STRENGTH LOAD LBS. (ASD)*	DESIGN STRENGTH LOAD LBS. (LRFD)*	WEIGHT UNIT	UNIT CUBE
3F-60	6' (72")	8-38956-00575-2	18,800	28,300	26 lbs	1.33
3F-70	7' (84")	8-38956-00584-4	16,900	25,400	36 lbs	1.55
3F-80	8' (96")	8-38956-00596-7	14,900	22,300	40 lbs.	1.77
3F-90	9' (108")	8-38956-00508-0	12,900	19,300	43 lbs.	1.99
3F-100	10' (120")	8-38956-00520-2	11,000	16,500	47 lbs.	2.21
3F-120	12' (144")	8-38956-00544-8	7,700	11,600	54 lbs.	2.66

### 3½" O.D., 11 GAUGE STEEL TUBING

35F-60	6' (72")	8-38956-00545-5	24,000	36,100	31 lbs.	1.33
35F-70	7' (84")	8-38956-00547-9	22,200	33,300	35 lbs.	1.55
35F-80	8' (96")	8-38956-00549-3	20,200	30,400	39 lbs.	1.77
35F-90	9' (108")	8-38956-00551-6	18,200	27,400	44 lbs.	1.99
35F-100	10' (120")	8-38956-00553-0	16,200	24,300	48 lbs.	2.21
35F-120	12' (144")	8-38956-00554-7	12,400	18,600	58 lbs.	2.66

### 4" O.D., 11 GAUGE STEEL TUBING

4F-60	6' (72")	8-38956-00555-4	29,100	43,700	35 lbs	1.33
4F-70	7' (84")	8-38956-00784-8	27,400	41,100	40 lbs.	1.55
4F-80	8' (96")	8-38956-00796-1	25,500	38,300	47 lbs.	1.77
4F-90	9' (108")	8-38956-00708-4	23,600	35,400	51 lbs.	1.99
4F-100	10' (120")	8-38956-00720-6	21,600	32,400	57 lbs.	2.21
4F-120	12' (144")	8-38956-00744-2	17,500	26,400	65 lbs.	2.66

### 3½" O.D., SCHEDULE 40

3540F-60	6' (72")	8-38956-00501-1	41,500	62,400	50 lbs	1.37
3540F-70	7' (84")	8-38956-00505-9	38,100	57,300	57 lbs.	1.59
3540F-80	8' (96")	8-38956-00508-0	34,600	52,000	65 lbs.	1.81
3540F-90	9' (108")	8-38956-00512-7	31,000	46,600	72 lbs.	2.03
3540F-100	10' (120")	8-38956-00516-5	27,400	41,200	80 lbs.	2.25
3540F-120	12' (144")	8-38956-00517-2	20,600	31,000	95 lbs.	2.70

\*Consult a registered professional engineer for column selection based on ASD or LRFD methodologies.

**ICC-ESR-1766**  
Complies with  
IBC and IRC  
Building  
Codes

- Minimum yield strength of 42,000 psi. complies with ASTM A500.
- Meets all FHA/HUD requirements.
- Finished with corrosion resistant coating that exceeds ASTM-B117-85. One year limited warranty.

**STANDARD END PLATE:** 4¼" X 7½" X .205"  
**"H" PLATE:** 4¼" X 7¼" X .205"  
(Please specify either Standard or H Series Plate when ordering)

# THE GRABBER SADDLE PLATE

SADDLE PLATE FOR LAMINATED (LVL) OR DIMENSIONAL LUMBER BEAMS.

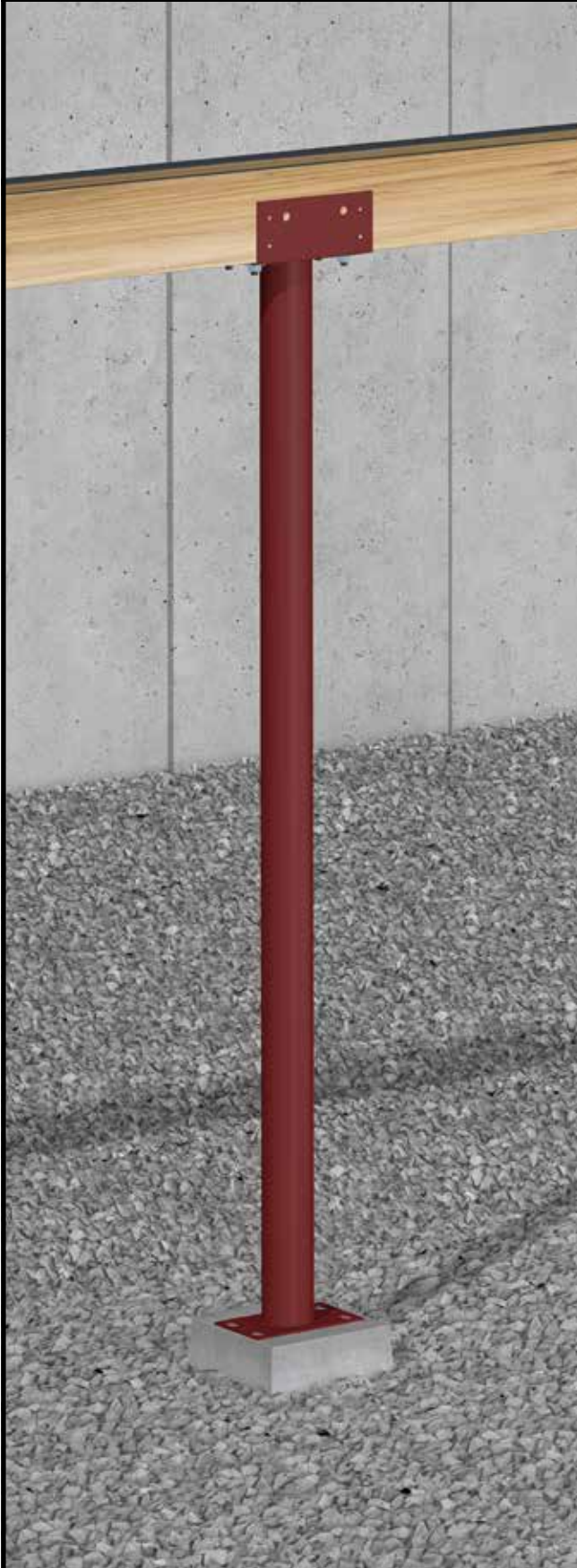

- The Grabber Saddle Plate provides lateral support for dimensional lumber beams and prevents the beam from torquing
- Allows for the through connection of fasteners into the side of the wood beam
- Some municipalities have required the use of a saddle plate for dimensional lumber or LVL beams in conjunction with Adjustable Steel Columns

## GRABBER SADDLE PLATE

PART#	DIMENSIONS	UPC	SHELF PACK	WT.PC.
SP5716	5 3/8" W x 3 9/16" H x 8" L	8-90475-001716-0	12	3.7 lbs.
SP3916	3 5/8" W x 3 9/16" H x 8" L	8-90475-001916-4	12	2.4 lbs.



If you are using a laminated (LVL) or dimensional lumber beam, you must use a saddle plate in conjunction with Adjustable Steel Columns per Wisconsin UDC (Uniform Dwelling Code).

Com21.22(3)(d) Lateral restraint for all wood beams shall be provided at all columns using a saddle plate or other approved connection where the beam meets one of the following conditions:

1. The beam is not restrained at both ends.
2. The beam is more than 11¼ inches deep using actual measurement.

# AREA WALLS

**ALL-STEEL, SINGLE-PIECE CONSTRUCTION FOR FAST, EASY INSTALLATION.**



- Area Walls provide more daylight and drainage for at-grade windows
- 22 gauge galvanized steel with deep corrugations for extra strength
- Fully rolled top for rigidity and safety
- Wide, pre-punched flat mounting flanges
- Single-piece construction up to 48" height – no welds

## ALL STEEL WINDOW WELLS

Round						Square					
MODEL#	HEIGHT/STYLE	UPC	BUNDLE	WEIGHT	UNIT CUBE	MODEL#	HEIGHT/STYLE	UPC	BUNDLE	WEIGHT	UNIT CUBE
AW 12R	12" Round	8-38956-00812-8	5	31 lbs.	4.63	AW 12S	12" Square	8-38956-00912-5	5	33 lbs.	3.85
AW 15R	15" Round	8-38956-00815-9	5	43 lbs.	5.78	AW 15S	15" Square	8-38956-00915-6	5	38 lbs.	4.82
AW 18R	18" Round	8-38956-00818-0	5	45 lbs.	6.94	AW 18S	18" Square	8-38956-00918-7	5	41 lbs.	5.78
AW 24R	24" Round	8-38956-00824-1	5	59 lbs.	9.25	AW 24S	24" Square	8-38956-00924-8	5	63 lbs.	7.71
AW 30R	30" Round	8-38956-00830-2	5	72 lbs.	11.56	AW 30S	30" Square	8-38956-00930-9	5	74 lbs.	9.64
AW 36R	36" Round	8-38956-00836-4	5	81 lbs.	13.88	AW 36S	36" Square	8-38956-00694-0	5	95 lbs.	11.56
AW 48R	48" Round	8-38956-00948-4	5	125 lbs.	18.50	AW 48S	48" Square	8-38956-00949-1	5	125 lbs.	15.42

**Round**  
37" wide  
16" projection  
accommodates 35"  
to 40" width

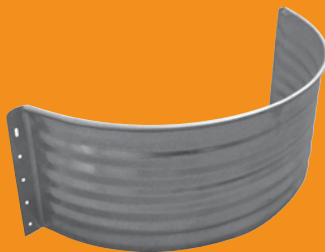

**Square**  
37" wide,  
13" projection

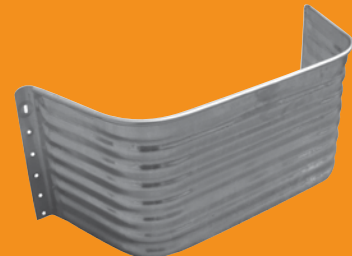

Standard Heights for Both Round & Square (approx.):  
12", 15", 18", 24", 30", 36", 48". Standard package: 5 per bundle