

Installation Instructions for the Sure-Lites SELW25 Emergency Light

WARNING

Risk of Fire / Electric Shock

If not qualified, consult an electrician.

WARNING

Risk of Electric Shock

Disconnect power at fuse or circuit breaker before installing or servicing.

Important Safeguards

When using electrical equipment, basic safety precautions should always be observed including the following:

- READ AND FOLLOW ALL SAFETY INSTRUCTIONS
- Do not use in hazardous locations, or near gas or electric heaters.
- Do not let power supply cords touch hot surfaces.
- Use caution when servicing batteries. Battery acid can cause burns to skin and eyes. If acid is spilled on skin or in eyes, flush acid with fresh water and contact a physician immediately.
- Do not use this equipment for other than the intended use.
- Installation is to be performed only by qualified personnel.
- Install in accordance with National Electric Code and local regulatory agency requirements.
- The use of accessory equipment not recommended by the manufacturer may cause an unsafe condition.
- Equipment should be mounted in locations and at heights where it will not readily be subjected to tampering by unauthorized personnel.
- SAVE THESE INSTRUCTIONS

INSTALLATION

1. De-energize the circuit at the junction box (J-box) where the emergency light is to be installed.
2. Open the emergency light by inserting a flat screwdriver in the two slots on the side of the unit, then turning to separate housing from the backplate.
3. To mount to a junction box - Drill out the appropriate mounting pattern and the wire pass hole in the backplate and the back gasket to fit the J-box being used.
4. To mount to conduit – Unscrew the ½” NPT plug located at the top of the fixture and screw in the user-supplied conduit hub.
5. Once the backplate is secured, the housing can be held in place during installation with the help of the two plastic strips (see Fig. 1 next page).
6. Connect the incoming wires to the SELW25 power supply wires using the wire nuts provided. Connect the white wire to neutral. If using 120V, connect the black wire to the hot lead. If using 277V, connect the orange wire to the hot lead. Cap the unused lead. Secure the emergency light to the wall and/or junction box using installer supplied hardware.
7. Complete the battery connection and snap the cover onto the backplate.
8. Energize AC supply. The test button should illuminate, and LED heads will illuminate briefly when the test button is pushed.
9. Adjust the heads as needed. The SELW25 lenses utilize a highly directional beam, and the lenses can be rotated to adjust the beams to the front or sides of the fixture (see Fig. 2 next page).

Figure 1

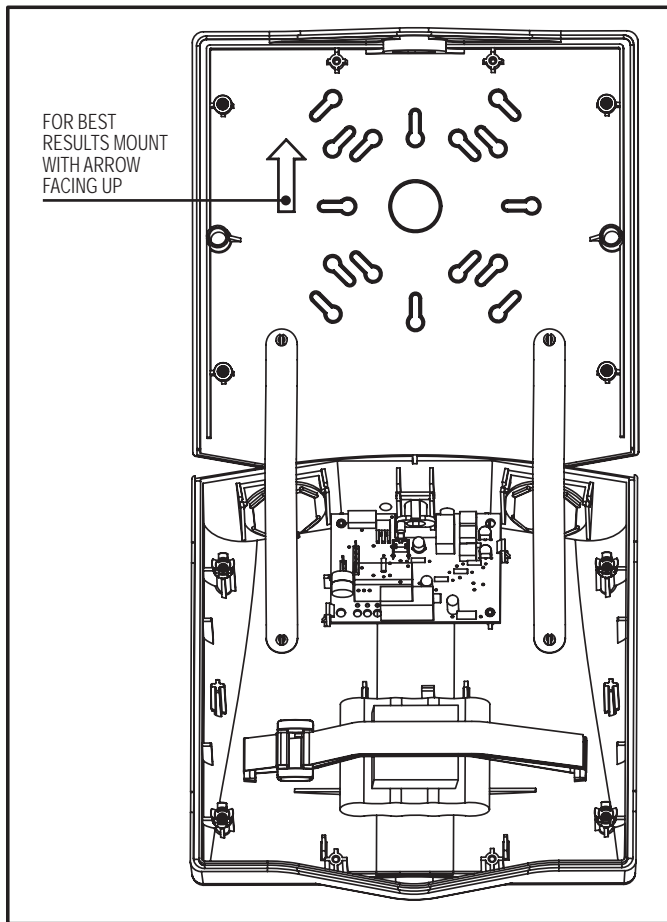
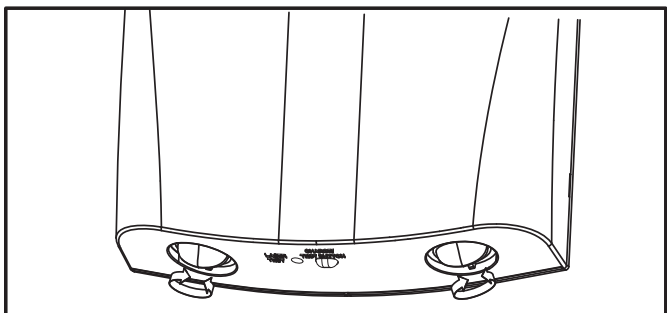

Figure 2



OPERATION

Depress the test switch. The LED heads will light and the charge LED will extinguish. LED heads will illuminate as long as the button is pushed. Release the test switch. The charge LED will illuminate and the LED heads will turn off.

MAINTENANCE:

None required. Replace the batteries as needed according to ambient conditions. Equipment should be tested every 30 days in accordance with local codes.

NOTE: Servicing of any parts should be performed by qualified personnel. Only use replacement parts supplied by Cooper Lighting Solutions. Use of unauthorized parts may void the warranty.

CAUTION: This equipment is furnished with a sophisticated low voltage battery dropout circuit to protect the battery from over discharge after its useful output has been used. Allow 24 hours recharge time after installation or power failure prior to 90 minute testing.

TROUBLE SHOOTING GUIDE

If LED heads or charge indicator LED does not illuminate, check the following:

1. Check AC supply – verify that unit has 24 hour AC supply.
2. Unit is shorted or battery is not connected.
3. Battery discharged. Permit unit to charge for 24 hours and then re-test.
4. If following the above trouble shooting hints does not solve your problem, contact your local Cooper Lighting Solutions Light rep-resentative for assistance

