

USA 800-766-0076
 Fax 323-890-4456
 www.smithcooper.com
 Los Angeles, CA
 Chicago, IL
 Atlanta, GA
 Vancouver, WA



Series 01728170

BRASS BALL VALVE, THREADED



WARNING: Cancer and Reproductive Harm -
www.P65Warnings.ca.gov

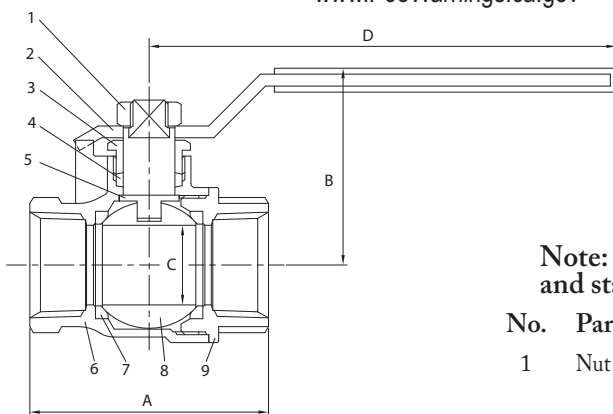

Pressure - Temperature Ratings

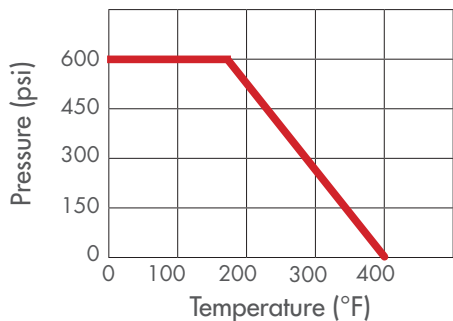

- 600 lb. WOG, 150 lb. WSP
- Full port
- Forged brass body
- Blow-out proof stem
- Chrome plated ball
- UL Listed (1/4" - 2") Threaded
- FM Approved, (1/2" - 2")
- CSA Approved under z21.15a for 1/2 psiG (1/2" - 2") - Threaded
- CSA Approved under 3-88 for 5 psig (1/2" - 2") - Threaded
- Approved under ANSI/ASM B16.33 spec for gas piping to 125 psig (1/2" - 2")
- Meets Fed Spec WW-V-35, Type II, Class A, Style 3 (1/2" - 2")
- Conforms to MSS-SP110
- Certified to NSF/ANSI 61.8
- ISO 9001:2008 manufacturer

Note: Product contains brass which does not meet federal and state requirements for drinking water.

No.	Part	Material
1	Nut	Forged Steel ASTM - AISI-1010 (1/8" - 2") - ASTM A-283 (2-1/2" - 4")
2	Handle	Forged Steel ASTM-A-283-D
3	Packing Nut	Brass ASTM B-16, C36000 (1/8" - 2") - ASTM B-124, C37700 (2-1/2" - 4")
4	Stem Packing	PTFE
5	Stem	Brass ASTM B-16, C36000 (1/8" - 2") - ASTM B-124, C37700 (2-1/2" - 4")
6	Body	Forged Brass ASTM B-124 C37700, (1/8" - 1 1/2") - Cast Brass ASTM B-584 C85700, (2" - 4")
7	Ball Seat	PTFE
8	Ball	Chrome Plated, Brass ASTM B-16, C36000, (1/8" - 1/2") Chrome Plated, Forged Brass ASTM B-124, C37700 (3/4" - 4")
9	Body End Cap	Forged Brass ASTM B-124, C37700

Size IN	Part Number	Weight LB	A IN	B IN	C IN	D IN	Cv
1/8	01728170A	0.34	1.81	1.37	0.37	3.23	6.5
1/4	01728170C	0.34	1.81	1.37	0.37	3.23	6.5
3/8	01728170E	0.34	1.81	1.37	0.37	3.23	6.5
1/2	01728170G	0.42	2.12	1.45	0.50	3.23	10.0
3/4	01728170I	0.83	2.41	1.78	0.75	3.94	26.0
1	01728170K	1.25	2.96	2.29	0.98	4.72	48.0
1-1/4	01728170L	2.05	3.28	2.44	1.24	4.72	70.0
1-1/2	01728170M	2.80	3.62	3.0	1.50	7.09	105.0
2	01728170N	4.72	4.21	3.30	1.98	7.09	200.0
2-1/2	01728170P	7.89	5.15	3.85	2.48	7.87	380
3	01728170Q	11.7	5.90	4.17	2.95	7.87	550
4	01728170T	16.0	7.38	6.00	3.85	10.5	1050

USA 800-766-0076
 Fax 323-890-4456
 www.smithcooper.com
 Los Angeles, CA
 Chicago, IL
 Atlanta, GA
 Vancouver, WA

Series 01728171

BRASS BALL VALVE, SWEAT



- 600 lb. WOG, 150 lb. WSP
- Full port
- Forged brass body
- Blow-out proof stem
- Chrome plated ball
- Meets Fed Spec WW-V-35, Type II, Class A, Style 3 (1/2" - 2")
- Conforms to MSS-SP110
- Certified to NSF/ANSI 61.8
- ISO 9001:2008 manufacturer

Note: Product contains brass which does not meet federal and state requirements for drinking water.

⚠ WARNING: Cancer and Reproductive Harm -
www.P65Warnings.ca.gov

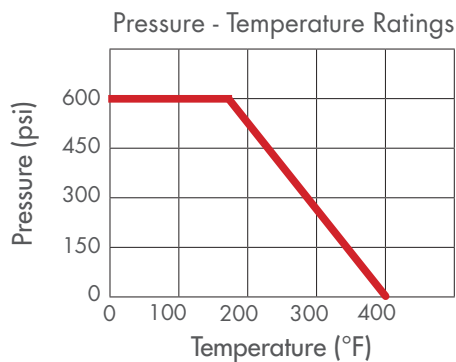
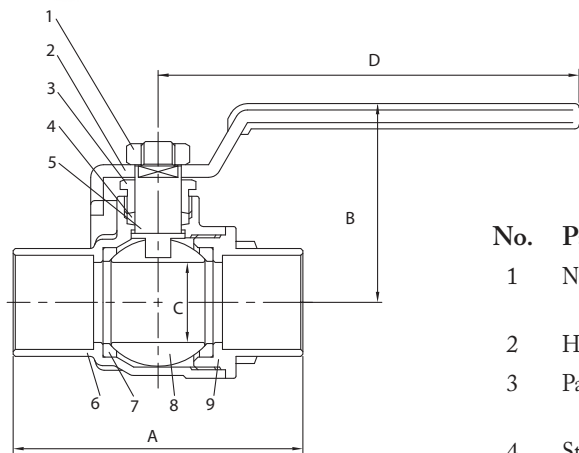

No.	Part	Material
1	Nut	Forged Steel ASTM - AISI-1010 (1/8" - 2") - ASTM A-283 (2-1/2" - 4")
2	Handle	Forged Steel ASTM-A-283-D
3	Packing Nut	Brass ASTM B-16, C36000 (1/8" - 2") - ASTM B-124, C37700 (2-1/2" - 4")
4	Stem Packing	PTFE
5	Stem	Brass ASTM B-16, C36000 (1/8" - 2") - ASTM B-124, C37700 (2-1/2" - 4")
6	Body	Forged Brass ASTM B-124 C37700, (1/8" - 1 1/2") - Cast Brass ASTM B-584 C85700, (2" - 4")
7	Ball Seat	PTFE
8	Ball	Chrome Plated, Brass ASTM B-16, C36000, (1/8" - 1/2") - Chrome Plated, Forged Brass ASTM B-124, C37700 (3/4" - 4")
9	Body End Cap	Forged Brass ASTM B-124, C37700

Size IN	Part Number	Weight LB	A IN	B IN	C IN	D IN	Cv
1/2	01728171G	0.37	1.94	1.45	0.50	3.23	10
3/4	01728171I	0.79	2.73	1.88	0.75	3.94	26
1	01728171K	1.16	3.29	2.29	0.98	4.72	48
1-1/4	01728171L	1.88	3.74	2.44	1.24	4.75	70
1-1/2	01728171M	2.57	4.30	3.0	1.50	7.09	105
2	01728171N	4.53	5.31	3.30	1.98	7.09	200
2-1/2	01728171P	6.88	6.34	4.17	2.55	7.87	380
3	01728171Q	11.24	7.17	4.96	2.95	9.84	550
4	01728171T	15.69	9.21	5.62	3.94	9.84	1050