

Valves





Ball Valves

- Stainless Steel
- Forged Steel
- Brass
- Ductile Iron
- PVC

Gate Valves

- Stainless Steel
- Forged Steel
- Brass
- Cast Steel
- Ductile Iron

Globe Valves

- Stainless Steel
- Forged Steel
- Brass
- Cast Steel

Check Valves

- Stainless Steel
- Forged Steel
- Brass
- Cast Steel
- PVC

Butterfly Valves

- Stainless Sanitary
- Ductile Iron
- Cast Iron

Straight Stops

- Brass
- PVC

Hose Bibbs / Sillcocks

- Brass
- PVC

Boiler Drains

- Brass
- PVC



SCI ProPak™ System

Series SC101 316 Stainless Steel One-Piece Ball Valve

- 1000# CWP, 150# WSP
- Reduced Port
- Body/Ball: ASTM A351 GR CF8M (SS316)
- Stem: ASTM A276 T-316
- Pressure balance hole in ball slot
- RTFE Seats
- Blow-Out Proof Stem
- Vacuum Service to 29" Hg
- Locking Handle
- Conforms to MSS SP-110
- ISO 9001:2008 Manufacturer
- Lead Free



Size in	Part Number	Packing		Weight lb
	Threaded	Inner	Master	
1/4	SC101C	30	120	0.14
3/8	SC101E	18	72	0.21
1/2	SC101G	12	48	0.39
3/4	SC101I	10	40	0.49
1	SC101K	8	32	0.82
1-1/4	SC101L	8	16	1.16
1-1/2	SC101M	6	12	1.64
2	SC101N	4	8	2.59

Series SC201 316 Stainless Steel Two-Piece Ball Valve

- 1000# CWP, 150# WSP
- Full Port
- Body/Ball: ASTM A351 GR CF8M (SS316)
- Stem: ASTM A276 T-316
- Pressure balance hole in ball slot
- RTFE Seats
- Blow-Out Proof Stem
- Vacuum Service to 29" Hg
- Locking Handle
- ISO 9001:2008 Manufacturer
- Conforms to MSS SP-110
- Lead Free



Size in	Part Number	Packing		Weight lb
	Threaded	Inner	Master	
1/4	SC201C	10	40	0.46
3/8	SC201E	10	40	0.46
1/2	SC201G	8	32	0.60
3/4	SC201I	12	24	0.87
1	SC201K	8	16	1.45
1-1/4	SC201L	6	12	2.13
1-1/2	SC201M	2	4	3.30
2	SC201N	2	4	5.70
2-1/2	SC201P	-	2	11.59
3	SC201Q	-	2	17.10

Series SC208 & SCL208 with Locking Handle

304 Stainless Steel Two-Piece Ball Valve

- 800# CWP, 150# WSP
- Full Port
- Body/Ball: ASTM A351 GR CF8 (SS304)
- Stem: ASTM A276 T-304
- RTFE Seats
- Blow-Out Proof Stem
- Vacuum Service to 29" Hg
- Locking Handle (SCL208 only)
- Pressure balance hole in ball slot
- Conforms to MSS SP-110
- ISO 9001:2008 Manufacturer
- Lead Free



Size in	Part Number		Packing		Weight lb
	Threaded	w/ Locking Handle	Inner	Master	
1/4	SC208C	SCL208C	12	48	0.36
3/8	SC208E	SCL208E	12	48	0.35
1/2	SC208G	SCL208G	8	32	0.52
3/4	SC208I	SCL208I	12	24	0.95
1	SC208K	SCL208K	8	16	1.21
1-1/4	SC208L	SCL208L	6	12	1.95
1-1/2	SC208M	SCL208M	4	8	2.74
2	SC208N	SCL208N	2	4	4.44

Series SC301 316 Stainless Steel Three-Piece Ball Valve

- 1000# CWP (1/4"-2") 600# CWP (2-1/2" - 4"), 150# WSP
- Full Port
- Body/Ball/End Caps: ASTM A351 GR CF8M (SS316)
- Stem: ASTM A 276 T-316
- Pressure balance hole in ball slot
- RTFE Seats
- Blow-Out Proof Stem
- Conforms to MSS SP-110
- Vacuum Service to 29" Hg
- Locking Handle
- ISO 9001:2008 Manufacturer
- Repair Kits, Lever Handles and Oval Handles Available
- Threaded and Socketweld Available
- Lead Free



Size in	Part Number		Packing		Weight lb
	Threaded	Socket Weld	Inner	Master	
1/4	SC301THC	-	6	24	0.67
3/8	SC301THE	-	6	24	0.68
1/2	SC301THG	SC301SWG	8	16	1.01
3/4	SC301THI	SC301SWI	8	16	1.33
1	SC301THK	SC301SWK	6	12	1.96
1-1/4	SC301THL	SC301SWL	4	8	2.96
1-1/2	SC301THM	SC301SWM	-	4	4.55
2	SC301THN	SC301SWN	-	3	7.13
2-1/2	SC301THP	-	-	2	15.87
3	SC301THQ	-	-	2	23.53
4	SC301THT	-	-	2	46.19

Series SC402 316 Stainless Steel Gate Valve

- 200# CWP, 125# WSP
- 316 Stainless Steel
- Solid Wedge Disc
- Screwed in Bonnet
- Non-Rising Stem
- ISO 9001:2008 Manufacturer
- Lead Free



Size in	Part Number	Packing	Weight lb
	Threaded	Master	
1/2	SC402G	30	0.9
3/4	SC402I	25	1.2
1	SC402K	20	1.5
1-1/4	SC402L	15	2.2
1-1/2	SC402M	10	3.4
2	SC402N	5	4.5

Series SC602 316 Stainless Steel Check Valve

- 200# CWP, 125# WSP
- 316 Stainless Steel
- Metal-to-Metal Seat
- Screwed Cap
- ISO 9001:2008 Manufacturer
- Lead Free



Size in	Part Number	Packing	Weight lb
	Threaded	Master	
1/2	SC602G	25	0.7
3/4	SC602I	16	1.0
1	SC602K	12	1.5
1-1/4	SC602L	9	2.2
1-1/2	SC602M	10	3.3
2	SC602N	8	4.7
2-1/2	SC602P	2	10.0
3	SC602Q	2	16.7

Series SC502 316 Stainless Steel Globe Valve

- 200# CWP, 125# WSP
- 316 Stainless Steel
- Metal-to-Metal Seat
- Screwed in Bonnet
- Rising Stem
- ISO 9001:2008 Manufacturer
- Lead Free



Size in	Part Number	Packing	Weight lb
	Threaded	Master	
1/2	SC502G	40	0.7
3/4	SC502I	25	1.0
1	SC502K	20	1.4
1-1/4	SC502L	15	1.5
1-1/2	SC502M	10	2.8
2	SC502N	6	4.7

Series SCYS8 316 Stainless Steel Threaded Wye Strainer

- 800# CWP, 150# WSP
- 20 Mesh 316 Stainless Steel Screen
- Start-up screen included
- Blow-Down Plug
- Lead Free
- Replacement Screens Available



Size in	Part Number	Weight lb
	Threaded	
1/2	SCYS8004	0.5
3/4	SCYS8006	0.8
1	SCYS8010	1.6
1-1/4	SCYS8012	2.0
1-1/2	SCYS8014	2.7
2	SCYS8020	4.3

Each valve is individually tagged with CWP and WSP pressure ratings, alloy of body, ball and stem, series number and notice of LEAD FREE.



Series 0384 PTFE Tape with Nickel

- Use on Stainless Steel Threads
- 90% PTFE / 10% Nickel
- Melting Point 620°F (327°C)
- Thickness .0045 (±.0005)
- ISO 9001:2008 Manufacturer
- ASTM Mill Spec T-27730A



Size in	Part Number	Length in	Packing		Weight lb
			Inner	Master	
1/2	0384260G	260	100	600	0.02
3/4	0384260I	260	50	300	0.04

Series S76BVH & S76SBVH

316 Stainless Steel Instrumentation Ball Valve

- 1000 psi @ 200° F
- PTFE seats
- Double ferrule instrumentation tube ends - S76BVH
- Single ferrule instrumentation tube ends - S76SBVH



Tube OD in	Part Number		Packing		Weight lb
	Double Ferrule	Single Ferrule	Inner	Master	
1/4	S76BVH002	S76SBVH002	1	10	0.4
3/8	S76BVH003	S76SBVH003	1	10	0.4
1/2	S76BVH004	S76SBVH004	1	10	0.7
3/4	S76BVH006	S76SBVH006	1	10	1.0
1	S76BVH010	S76SBVH010	1	10	1.6

Series S76BVH6

316 Stainless Steel Instrumentation Ball Valve

- 6000 psi @ 200° F
- PTFE seats
- Double ferrule instrumentation tube ends



Tube OD in	Part Number	Packing		Weight lb
	Instrumentation	Inner	Master	
1/4	S76BVH6002	1	10	0.4
3/8	S76BVH6003	1	10	0.4
1/2	S76BVH6004	1	10	0.7
3/4	S76BVH6006	1	10	1.0
1	S76BVH6010	1	10	1.6

Series S76BVH3

316 Stainless Steel Instrumentation Ball Valve

- 3000 psi @ 200° F
- PTFE seats
- Double ferrule instrumentation tube ends



Tube OD in	Part Number	Packing		Weight lb
	Instrumentation	Inner	Master	
1/4	S76BVH3002	1	10	0.6
3/8	S76BVH3003	1	10	0.7
1/2	S76BVH3004	1	10	0.8
3/4	S76BVH3006	1	10	1.6
1	S76BVH3010	1	10	2.5

Series S76PCV3 & S76SPCV3

316 Stainless Steel Instrumentation Check Valve

- 3000 psi @ 200° F
- Cracking Pressure 7 psi
- PTFE seats
- Double ferrule instrumentation tube ends - S76PCV3
- Single ferrule instrumentation tube ends - S76SPCV3



Tube OD in	Part Number		Packing		Weight lb
	Double Ferrule	Single Ferrule	Inner	Master	
1/4	S76PCV3002	S76SPCV3002	1	10	0.3
3/8	S76PCV3003	S76SPCV3003	1	10	0.3
1/2	S76PCV3004	S76SPCV3004	1	10	0.5
3/4	S76PCV3006	S76SPCV3006	1	10	0.6
1	S76PCV3010	S76SPCV3010	1	10	1.5

Series S7166NV

316 Stainless Steel Needle Valve

- 6000 lb. CWP
- Straight pattern
- NPT threaded ends
- 0°F to 450°F



Size in	Part Number	Weight lb
	Threaded	
1/4	S7166NV002	1.0
3/8	S7166NV003	1.1
1/2	S7166NV004	1.6
3/4	S7166NV006	1.9
1	S7166NV010	3.1

For our complete line of instrumentation see pages 91-104.

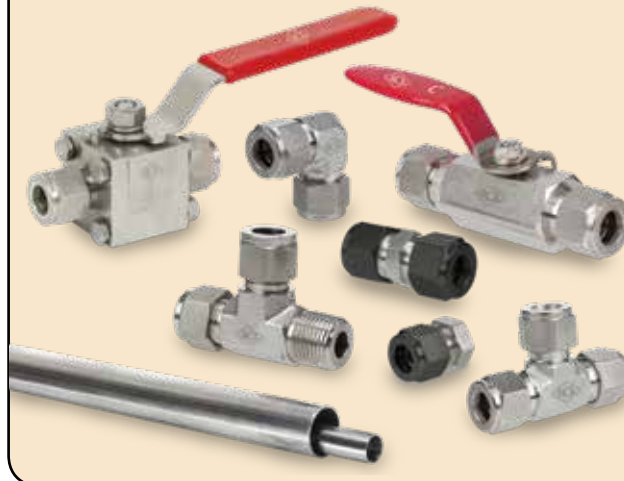

**Series 8170
Brass Ball Valve**

- 600 lb. CWP, 150 lb. WSP
- Full port
- PTFE seats and seals
- Forged brass body
- Blow-out proof stem
- Chrome plated ball
- UL Listed (1/4" – 2") threaded
- F/M Approved, (1/2" – 2")
- CSA Approved under z21.15a for 1/2 psig (1/2" – 2") – threaded
- CSA Approved under 3-88 for 5 psig (1/2" – 2") – threaded
- Approved under ANSI/ASME B16.33 spec for Gas Piping to 125 psig (1/2" – 2")
- Meets Fed Spec WW-V-35, Type II, Class A, Style 3 (1/2" – 2")
- Conforms to MSS-SP110
- Certified to NSF/ANSI 61-8
- ISO 9001:2008 manufacturer



Size in	Part Number Threaded	Packing		Weight lb
		Inner	Master	
1/4	01728170C	10	160	0.4
3/8	01728170E	10	160	0.3
1/2	01728170G	10	160	0.5
3/4	01728170I	6	72	0.7
1	01728170K	4	48	1.0
1-1/4	01728170L	4	24	1.7
1-1/2	01728170M	6	18	2.3
2	01728170N	4	8	3.5
2-1/2	01728170P	1	6	7.9
3	01728170Q	2	4	11.7
4	01728170T	1	2	22.1

**Series 8145
Brass Ball Valve**

- 600 lb. CWP, 150 lb. WSP
- Full port
- Forged brass body
- Chrome plated ball
- PTFE seats and seals
- Blow-out proof stem
- Certified to NSF/ANSI 61-8
- ISO 9001:2008 manufacturer



Size in	Part Number Threaded	Packing		Weight lb
		Inner	Master	
1/4	01728145C	12	120	0.4
3/8	01728145E	12	120	0.3
1/2	01728145G	8	96	0.4
3/4	01728145I	6	72	0.6
1	01728145K	6	36	0.9
1-1/4	01728145L	6	24	1.3
1-1/2	01728145M	2	16	2.1
2	01728145N	2	12	3.1

**Series 8155 & 8156
Brass Ball Valve**

- 600 lb. CWP, 150 lb. WSP
- Full port
- PTFE seats and seals
- Forged brass body
- Chrome plated ball
- Blow-out proof stem
- CSA approved (1/2 thru 2) - threaded
- ISO 9001:2008 manufacturer



Size in	Part Number		Packing		Weight lb
	Threaded	Sweat	Inner	Master	
1/4	01728155C	-	10	160	0.3
3/8	01728155E	-	10	160	0.3
1/2	01728155G	01728156G	10	120	0.5
3/4	01728155I	01728156I	10	60	0.7
1	01728155K	01728156K	6	60	1.0
1-1/4	01728155L	01728156L	4	24	1.7
1-1/2	01728155M	01728156M	4	16	2.3
2	01728155N	01728156N	2	16	3.5
2-1/2	01728155P	01728156P	1	6	7.2
3	01728155Q	01728156Q	2	4	8.8
4	01728155T	01728156T	1	2	16.5

**Series 8135
Brass Ball Valve**

- 400 lb. CWP, 150 lb. WSP
- Standard port
- Forged brass body
- Chrome plated ball
- PTFE seats and seals
- Blow-out proof stem
- Certified to NSF/ANSI 61-8
- ISO 9001:2008 manufacturer



Size in	Part Number Threaded	Packing		Weight lb
		Inner	Master	
1/4	01728135C	12	120	0.3
3/8	01728135E	12	120	0.3
1/2	01728135G	12	120	0.4
3/4	01728135I	8	96	0.5
1	01728135K	8	48	0.9
1-1/4	01728135L	8	32	1.1
1-1/2	01728135M	4	24	1.7
2	01728135N	2	16	2.4
2-1/2	01728135P	2	8	5.4
3	01728135Q	2	4	8.2
4	01728135T	2	4	13.1

Note: Product contains brass which does not meet federal and state requirements for drinking water.

WARNING: Cancer and Reproductive Harm - www.P65Warnings.ca.gov

Series 8140 & 8141 Lever Handle Series 8142 Slotted Stem Mini Brass Ball Valves

- 600 lb. CWP, 150 lb. WSP
- Forged brass body
- PTFE seats and seals
- ISO 9001:2008 manufacturer



Size in	Part Number	Ends Config.	Packing		Weight lb
			Inner	Master	
1/4 x 1/4	01728140CC	FIP x FIP	50	300	0.2
1/8 x 1/8	01728141AA	FIP x MIP	25	300	0.2
1/4 x 1/8	01728141CA	FIP x MIP	25	300	0.2
1/4 x 1/4	01728141CC	FIP x MIP	50	400	0.2
1/4 x 1/4	01728142CC	FIP x MIP	25	300	0.1

Series 9191 & 9192 Brass Swing Check Valve

- 200 lb. CWP, 125 lb. WSP
- Cast brass
- Forged brass disc
- ISO 9001:2008 manufacturer



Size in	Part Number		Packing		Weight lb
	Threaded	Sweat	Inner	Master	
3/8	01739191E	-	25	150	0.4
1/2	01739191G	01739192G	20	120	0.4
3/4	01739191I	01739192I	12	72	0.5
1	01739191K	01739192K	10	60	0.7
1-1/4	01739191L	01739192L	8	32	1.3
1-1/2	01739191M	01739192M	5	20	1.6
2	01739191N	01739192N	4	16	2.6
2-1/2	01739191P	01739192P	1	8	4.5
3	01739191Q	01739192Q	1	8	6.6
4	01739191T	-	1	4	11.4

Series 9193 Brass Swing Check Valve Soft Seat*

- Full floating disc
- 200 lb. CWP
- Cast brass



Size in	Part Number	Packing		Weight lb
		Inner	Master	
1/2	01739193G	20	120	0.4
3/4	01739193I	12	72	0.5
1	01739193K	10	60	0.7
1-1/4	01739193L	8	32	1.3
1-1/2	01739193M	5	20	1.6
2	01739193N	4	16	2.6

Series CV30 Brass In-Line Check Valve

- Rated at 200 psi
- Cast brass
- EPDM seat and seal
- Spring loaded, stainless steel spring, opens at 2 psi



Size in	Part Number	Packing		Weight lb
		Threaded Ends	Inner	
1/2	0209CV30G	10	150	0.4
3/4	0209CV30I	18	108	0.6
1	0209CV30K	10	60	0.9
1-1/4	0209CV30L	8	40	1.5
1-1/2	0209CV30M	5	30	1.5
2	0209CV30N	4	24	3.5

Series 8501 & 8502 Brass Gate Valve

- 200 lb. CWP, 125 lb. WSP
- Full port (1/4 - 3)
- Cast brass
- Screwed in bonnet
- Non-rising brass stem
- ISO 9001:2008 manufacturer
- Brass cross handles available



Size in	Part Number		Packing		Weight lb
	Threaded	Sweat	Inner	Master	
1/4	01718501C	-	12	72	0.5
3/8	01718501E	01718502E	12	72	0.5
1/2	01718501G	01718502G	12	72	0.6
3/4	01718501I	01718502I	14	56	0.8
1	01718501K	01718502K	5	40	1.1
1-1/4	01718501L	01718502L	3	18	1.8
1-1/2	01718501M	01718502M	6	24	2.2
2	01718501N	01718502N	4	16	3.3
2-1/2	01718501P	01718502P	1	6	6.4
3	01718501Q	01718502Q	1	6	9.7
4	01718501T	-	1	4	17.0

Series 9101 Bronze Gate Valve

- 300 lb. CWP, 150 lb. WSP
- Full port (1/2 - 3)
- ASTM B-62 bronze
- Solid wedge disc
- Screwed in bonnet
- Non-rising stem
- Conforms to MSS SP-80
- Cast iron star handle
- ISO 9001:2008 manufacturer



Size in	Part Number	Packing		Weight lb
		Threaded	Inner	
1/2	01719101G	12	72	0.6
3/4	01719101I	14	56	1.0
1	01719101K	5	40	1.3
1-1/4	01719101L	3	18	1.9
1-1/2	01719101M	6	24	2.3
2	01719101N	4	16	3.5
2-1/2	01719101P	1	6	6.7
3	01719101Q	1	6	9.1
4	01719101T	1	4	15.7

Note: Product contains brass which does not meet federal and state requirements for drinking water.



WARNING: Cancer and Reproductive Harm - www.P65Warnings.ca.gov

Series 200
Straight Gas Ball Valve, FIP



- Lever/tee handle, UL Listed
- Forged brass body, two-piece
- Blow-out proof stem
- ISO 9001:2008 manufacturer



Size in	Part Number	Packing		Weight lb
	FIP x FIP	Inner	Master	
3/8	0190200E	10	100	0.3
1/2	0190200G	10	100	0.3
3/4	0190200I	10	100	0.5
1	0190200K	6	48	0.9

Series 230
Straight Gas Ball Valve, FIP x Flare



- Lever/tee handle, UL Listed
- Forged brass body, two-piece
- Blow-out proof stem
- ISO 9001:2008 manufacturer



Size in	Part Number	Packing		Weight lb
	FIP x Flare	Inner	Master	
1/2 x 3/8	0190230GE	10	100	0.4
1/2 x 1/2	0190230GG	10	100	0.4
1/2 x 9/16	0190255XG	10	100	0.4
1/2 x 5/8	0190230GH	10	100	0.4
3/4 x 5/8*	0190230IH	10	80	0.5

*5/8 Flare connection 15/16-16 threads

Series 235
Angle Gas Ball Valve, FIP x Flare



- Lever/tee handle, UL Listed
- Forged brass body, two-piece
- Blow-out proof stem
- ISO 9001:2008 manufacturer



Size in	Part Number	Packing		Weight lb
	FIP x Flare	Inner	Master	
1/2 x 3/8	0190235GE	12	144	0.4
1/2 x 1/2	0190235GG	12	144	0.4
3/4 x 5/8*	0190235IH	12	144	0.6

*5/8 Flare connection 15/16-16 threads

Series 236
Straight Gas Ball Valve, Flare



- Lever/tee handle, UL Listed
- Forged brass body, two-piece
- Blow-out proof stem
- ISO 9001:2008 manufacturer



Size in	Part Number	Packing		Weight lb
	Flare x Flare	Inner	Master	
3/8	0190236EE	10	100	0.4
1/2	0190236GG	10	100	0.4

Series 236
Straight Gas Ball Valve, Flare

- Lever/tee handle, UL Listed
- Forged brass body, two-piece
- Blow-out proof stem
- ISO 9001:2008 manufacturer



Size in	Part Number	Packing		Weight lb
	Flare x Flare	Inner	Master	
3/8	0190236EE	10	100	0.4
1/2	0190236GG	10	100	0.4

Series 250
Straight Gas Ball Valve, FIP



- Square operator, UL Listed
- Forged brass body, two-piece
- Blow-out proof stem
- ISO 9001:2008 manufacturer



Size in	Part Number	Packing		Weight lb
	FIP x FIP	Inner	Master	
1/2	0190250G	12	144	0.3
3/4	0190250I	12	144	0.5

All Gas Valves are certified to:
Fed. Spec. WW-V-35, Type II Class A, Style 3 / CSA Approved
(ANSI z21.15a for 1/2 psiG) / CSA Approved (3-88 spec 5 psiG
Residential Gas)

WARNING: Cancer and Reproductive Harm -
www.P65Warnings.ca.gov

Series 0383
PTFE Tape (Virgin)

- Melting point 620°F (327°C)
- Thickness .0035 (±.0005)
- ISO 9001:2008 manufacturer
- ASTM Mil Spec T-27730A
- Manufactured especially for natural gas, propane, butane, water, oil and chemical lines



Size in	Part Number	Length in	Packing		Weight lb
			Inner	Master	
1/2	0383260GY	260	100	600	0.1

Series 160 Iron Body Butterfly Valve

- 200 psi (2" - 12")
- 150 psi (14" & 16")
- Wafer body - Cast Iron
- Lug body - Ductile Iron
- Disc materials: 316 stainless steel, nickel plated ductile iron or aluminum bronze
- Seat materials: EPDM or BUNA-N
- Lug or wafer connections
- Stainless steel stem
- Fusion bonded epoxy coating

- MSS SP-67/API 609
- ISO 5211 mounting pad
- Install between ANSI Class 125/150 flanges
- Not suitable for dead-end service or steam
- ISO 9001:2008 manufacturer
- Stem extensions available
- Phenolic backed cartridge seat
- Bi-Directional service
- Self lubricating bushings

0160W D E L 020

Valve Style	
0160W	Wafer
0160L	Lug

Disc Material	
S	316 Stainless Steel
D	Nickel Plated Ductile Iron
A	Aluminum Bronze*

Seat Material	
E	EPDM
N	BUNA-N

Operator	
L	10 Position Lever Handle
G	Gear Operator w/ Handwheel
N	Gear Operator w/ Op. Nut

Size in	
020	2
024	2-1/2
030	3
040	4
050	5
060	6
080	8
100	10
120	12
140	14
160	16



*Denotes Special Order - Lead Times Will Vary, Call For More Information

Series 17

Ductile Iron Body Butterfly Valve

- 200 psi (2" - 12")
- 150 psi (14" - 48")
- Ductile iron body
- Disc materials: 316 stainless steel
- Seat materials: EPDM or BUNA-N
- Lug or wafer
- MSS SP - 67 and API 609 compliant
- MSS SP - 25 marking
- Self-lubricating bushings
- Blow-out proof shaft
- Epoxy coated
- ISO 5211 mounting pad
- For bi-directional or dead-end service
- Valves available with undercut discs to 50 psi maximum working pressure
- Phenolic backed cartridge seat
- Stem extensions available



Series 17 Gear Operator

- Nine Sizes
- From 1,500 - 26,400 In/ lb.
- Fits Series 17 Butterfly Valves
- ISO Bolt Circle
- Cast Iron Body
- Visual Position Indicator
- Can be fitted for chainwheels, other handwheels or limit switches



SV17W 2 6 4 1 2 020

Valve Style		Body Material		Disc Material		Shaft Material		Seat Material		Operator		Size in	
SV17W	Wafer	2	Ductile Iron (A356)	6	316 Stainless Steel	4	Stainless Steel 416	1	EPDM	1	10 Position Lever Handle	020	2
SV17L	Lug							2	BUNA-N	2	Gear Operator	024	2-1/2
										7	Gear w/ Chain Wheel	030	3
										8	Bare Stem	040	4
												050	5
												060	6
												080	8
												100	10
												120	12
												140	14
												160	16
												180	18
												200	20
												240	24
												260	26
												300	30
												340	34
												360	36
												420	42
												480	48



*Denotes Special Order - Lead Times Will Vary, Call For More Information

Series 017135FW UL/FM AWWA Resilient Wedge OS&Y Gate Valve, Flanged



- Sizes 2 1/2"-12"
- 300 lb. non-shock cold working pressure
- Ductile iron body and bonnet
- EPDM rubber encapsulated ductile iron wedge
- 304 Stainless Steel stem
- Wax encapsulated stainless cap screws
- Fusion bonded epoxy coating AWWA C550
- Meets AWWA C515
- Certified to ANSI/NSF 61 & 372 (Lead Free)
- UL Listed / FM Approved
- Grooved stem for tamper switch
- Pre-tapped and plugged for bypass with additional bosses
- Brand for full traceability



Series 017135FGW UL/FM AWWA Resilient Wedge OS&Y Gate Valve, Flanged x Grooved



- 300 lb. non-shock cold working pressure
- Ductile iron body and bonnet
- 304 Stainless Steel stem
- Wax encapsulated stainless cap screws
- EPDM rubber encapsulated ductile iron wedge
- Fusion bonded epoxy coating AWWA C550
- Meets AWWA C515
- Grooved dimensions meet AWWA C-606
- Certified to ANSI/NSF 61 & 372 (Lead Free)
- UL Listed / FM Approved
- Grooved stem for tamper switch
- Tapped and plugged for by-pass with additional bosses
- Brand for full traceability



Size in	Part Number	Weight lb
2-1/2	017135FW024	39
3	017135FW030	51
4	017135FW040	71
6	017135FW060	117
8	017135FW080	201
10	017135FW100	296
12	017135FW120	440

Size in	Part Number	Weight lb
4	017135FGW040	61
6	017135FGW060	104
8	017135FGW080	181

Series 017135GW UL/FM Resilient Wedge OS&Y Gate Valve, Grooved



- 300 lb. non-shock cold working pressure
- Ductile iron body and bonnet
- 304 Stainless Steel stem
- Wax encapsulated stainless cap screws
- EPDM rubber encapsulated ductile iron wedge
- Fusion bonded epoxy coating AWWA C550
- Grooved dimensions meet AWWA C-606
- Certified to ANSI/NSF 61 & 372 (Lead Free)
- UL Listed / FM Approved
- Grooved stem for tamper switch
- Pre-tapped and plugged for by-pass with additional bosses
- Brand for full traceability



Size in	Part Number	Weight lb
4	017135GW040	53
6	017135GW060	91
8	017135GW080	162

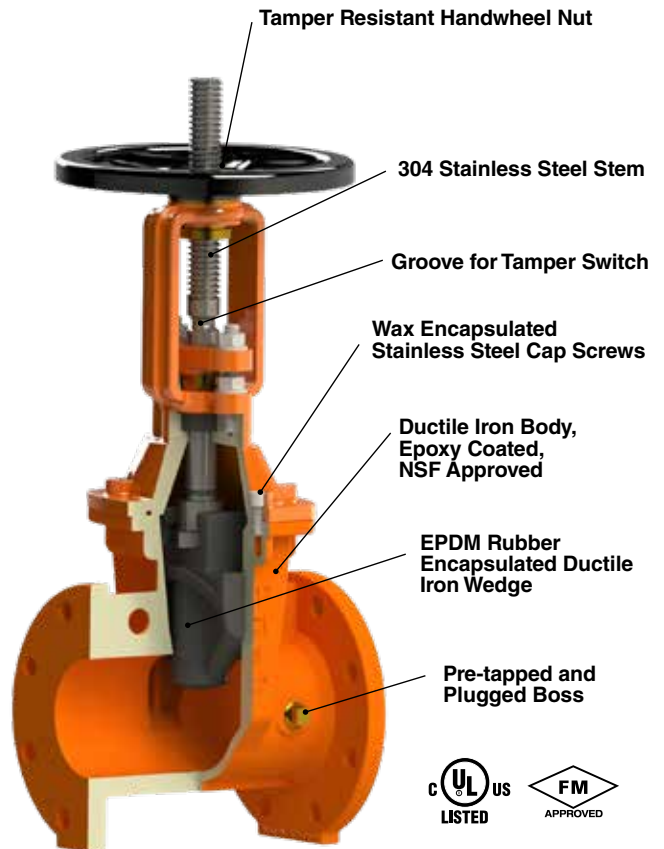

Link to OS&Y Valve Submittal



www.smithcooper.com/QROSY



Series 017115FW
UL/FM AWWA Resilient Wedge
NRS Gate Valve, Flanged - Handwheel



- 300 lb. non-shock cold working pressure
- Ductile iron body and bonnet
- EPDM rubber encapsulated ductile iron wedge
- 304 Stainless Steel non-rising stem
- Wax encapsulated stainless cap screws
- Fusion bonded epoxy coating AWWA C550
- Meets AWWA C515
- Certified to ANSI/NSF 61 & 372 (Lead Free)
- UL Listed / FM Approved
- Brand for full traceability



Size in	Part Number	Weight lb
2	017115FW020	29
2-1/2	017115FW024	35
3	017115FW030	46
4	017115FW040	65
6	017115FW060	108
8	017115FW080	180
10	017115FW100	251
12	017115FW120	400

Series 017115FN
UL/FM AWWA Resilient Wedge NRS
Gate Valve, Flanged - Op Nut

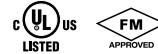

- 300 lb. non-shock cold working pressure
- Ductile iron body and bonnet
- EPDM rubber encapsulated ductile iron wedge
- 304 Stainless Steel non-rising stem
- Wax encapsulated stainless cap screws
- Fusion bonded epoxy coating AWWA C550
- Meets AWWA C515
- Certified to ANSI/NSF 61 & 372 (Lead Free)
- UL Listed / FM Approved
- Brand for full traceability



Size in	Part Number	Weight lb
2	017115FN020	29
2-1/2	017115FN024	35
3	017115FN030	46
4	017115FN040	65
6	017115FN060	108
8	017115FN080	180
10	017115FN100	251
12	017115FN120	400

Series 017115MFN
UL/FM AWWA Resilient Wedge NRS
Gate Valve, Flanged x MJ - Op Nut

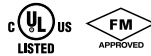

- 300 lb. non-shock cold working pressure
- Ductile iron body and bonnet
- EPDM rubber encapsulated ductile iron wedge
- 304 Stainless Steel non-rising stem
- Wax encapsulated stainless cap screws
- Fusion bonded epoxy coating AWWA C550
- Meets AWWA C515
- Certified to ANSI/NSF 61 & 372 (Lead Free)
- UL Listed / FM Approved
- Brand for full traceability



Size in	Part Number	Weight lb
3	017115MFN030	46
4	017115MFN040	62
6	017115MFN060	103
8	017115MFN080	175
10	017115MFN100	270
12	017115MFN120	404

Series 017115MN
UL/FM AWWA Resilient Wedge NRS
Gate Valve, Mechanical Joint - Op Nut



- 300 lb. non-shock cold working pressure
- Ductile iron body and bonnet
- EPDM rubber encapsulated ductile iron wedge
- 304 Stainless Steel non-rising stem
- Wax encapsulated stainless cap screws
- Fusion bonded epoxy coating AWWA C550
- Meets AWWA C515
- Certified to ANSI/NSF 61 & 372 (Lead Free)
- UL Listed / FM Approved
- Brand for full traceability



Size in	Part Number	Weight lb
3	017115MN030	46
4	017115MN040	62
6	017115MN060	103
8	017115MN080	175
10	017115MN100	270
12	017115MN120	404

Series 10MN*

- Nitrile rubber encapsulated ductile iron wedge

Size in	Part Number	Weight lb
	Mechanical Joint	
14	017110MN140	875
16	017110MN160	1225
18	017110MN180	1436

Link to NRS
Valve Submittal



www.smithcooper.com/QRNRS

* Not UL/FM



Series 017115FGW UL/FM AWWA Resilient Wedge NRS Gate Valve, Flanged x Grooved

- 300 lb. non-shock cold working pressure
- Ductile iron body and bonnet
- EPDM rubber encapsulated ductile iron wedge
- 304 Stainless Steel non-rising stem
- Wax encapsulated stainless cap screws
- Fusion bonded epoxy coating AWWA C550
- Meets AWWA C515
- Grooved dimensions meet AWWA C-606
- Certified to ANSI/NSF 61 & 372 (Lead Free)
- UL Listed / FM Approved
- Brand for full traceability



Size in	Part Number	Weight lb
3	017115FGW030	44
4	017115FGW040	61
6	017115FGW060	104
8	017115FGW080	180
10	017115FGW100	290



Series 017115GW UL/FM Resilient Wedge NRS Gate Valve, Grooved End

- 300 lb. non-shock cold working pressure
- Ductile iron body and bonnet
- EPDM rubber encapsulated ductile iron wedge
- 304 Stainless Steel non-rising stem
- Wax encapsulated stainless cap screws
- Fusion bonded epoxy coating AWWA C550
- Meets AWWA C515
- Grooved dimensions meet AWWA C-606
- Certified to ANSI/NSF 61 & 372 (Lead Free)
- UL Listed / FM Approved
- Brand for full traceability



Size in	Part Number	Weight lb
4	017115GW040	48
6	017115GW060	83
8	017115GW080	149



Series 017125FN UL/FM AWWA Resilient Wedge NRS Gate Valve, Flanged w/ Top Plate

- 300 lb. non-shock cold working pressure
- Ductile iron body and bonnet
- EPDM rubber encapsulated ductile iron wedge
- 304 Stainless Steel non-rising stem
- Wax encapsulated stainless cap screws
- Fusion bonded epoxy coating AWWA C550
- Meets AWWA C515
- Certified to ANSI/NSF 61 & 372 (Lead Free)
- UL Listed / FM Approved
- Brand for full traceability



Size in	Part Number	Weight lb
4	017125FN040	79
6	017125FN060	119
8	017125FN080	189
10	017125FN100	258
12	017125FN120	396



Series 017125MFN UL/FM AWWA Resilient Wedge NRS Gate Valve, Flanged x MJ w/ Top Plate

- 300 lb. non-shock cold working pressure
- Ductile iron body and bonnet
- EPDM rubber encapsulated ductile iron wedge
- 304 Stainless Steel non-rising stem
- Wax encapsulated stainless cap screws
- Fusion bonded epoxy coating AWWA C550
- Meets AWWA C515
- Certified to ANSI/NSF 61 & 372 (Lead Free)
- UL Listed / FM Approved
- Brand for full traceability



Size in	Part Number	Weight lb
4	017125MFN040	78
6	017125MFN060	117
8	017125MFN080	186
10	017125MFN100	276
12	017125MFN120	417

Link to NRS
Valve Submittal

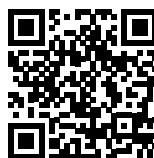

www.smithcooper.com/QRNRS



Series 017125MFN
UL/FM AWWA Resilient Wedge
NRS Gate Valve, MJ w/ Top Plate

- 300 lb. non-shock cold working pressure
- Ductile iron body and bonnet
- EPDM rubber encapsulated ductile iron wedge
- 304 Stainless Steel non-rising stem
- Wax encapsulated stainless cap screws
- Fusion bonded epoxy coating AWWA C550
- Meets AWWA C515
- Certified to ANSI/NSF 61 & 372 (Lead Free)
- UL Listed / FM Approved
- Brand for full traceability



Series 017125WP
UL/FM AWWA Indicator Post, Wall

- Cast iron body
- Stainless Steel Op Nut
- Fusion bonded epoxy coating
- UL Listed / FM Approved
- Brand for full traceability



Size in	Part Number	Weight lb
4	017125MN040	78
6	017125MN060	120
8	017125MN080	191
10	017125MN100	286
12	017125MN120	419

Size in	Part Number	Weight lb
	Mechanical Joint x Flanged	
-	017125WP	90

Series 017125PI3672
UL/FM AWWA Indicator Post, Vertical

- Adjustable from 36" to 72"
- Cast iron body
- Stainless Steel Op Nut
- Fusion bonded epoxy coating
- UL Listed / FM Approved
- Brand for full traceability



Size in	Part Number	Weight lb
	Mechanical Joint	
36 - 72	017125PI3672	220



Link to Post Indicator
Submittal

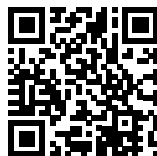

www.smithcooper.com/QRPOST

**Series 10FW
Flanged Gate Valve
with Handwheel**

- 250 lb. non-shock cold working pressure
- Ductile iron body and bonnet
- Nitrile rubber encapsulated ductile iron wedge
- Stainless steel non-rising stem
- Wax encapsulated stainless steel cap screws
- Fusion bonded epoxy coating
- Meets AWWA C515



Size in	Part Number	Weight lb
	Flanged	
2	017110FW020	32
2-1/2	017110FW025	43
3	017110FW030	53
4	017110FW040	74
6	017110FW060	150
8	017110FW080	215
10	017110FW100	335
12	017110FW120	478
14	017110FW140	868
16	017110FW160	1224

**Series 10FN
Flanged Gate Valve
with Operating Nut**

- 250 lb. non-shock cold working pressure
- Ductile iron body and bonnet
- Nitrile rubber encapsulated ductile iron wedge
- Stainless steel non-rising stem
- Wax encapsulated stainless steel cap screws
- Fusion bonded epoxy coating
- Meets AWWA C515



Size in	Part Number	Weight lb
	Flanged	
2	017110FN020	32
2-1/2	017110FN025	43
3	017110FN030	53
4	017110FN040	74
6	017110FN060	150
8	017110FN080	215
10	017110FN100	335
12	017110FN120	478
14	017110FN140	868
16	017110FN160	1224

**Series 10RN
Ring Tite Joint IPS Gate Valve
with Operating Nut**

- 250 lb. non-shock CWP
- Ductile iron body and bonnet
- Stainless steel non-rising stem
- Wax encapsulated stainless steel cap screws
- Fusion bonded epoxy coating
- Meets AWWA C515
- IPS pipe size



Size in	Part Number	Weight lb
	Push On	
2	017110RN020	27
2-1/2	017110RN025	38
3	017110RN030	47
4	017110RN040	69
6	017110RN060	146
8	017110RN080	208

**Series 10NW & 10NN
IPS Threaded Gate Valve
with Handwheel or Operating Nut**

- 250 lb. non-shock CWP
- Ductile iron body and bonnet
- Stainless steel non-rising stem
- Wax encapsulated stainless steel cap screws
- Fusion bonded epoxy coating
- Meets AWWA C515



Size in	Part Number		Weight lb
	Hand Wheel	Op Nut	
2	017110NW020	017110NN020	24
3	017110NW030	017110NN030	49
4	017110NW040	017110NN040	68

Series 22FC
Flanged Ductile Iron Swing Check Valve

- 300 lb. CWP
- Meets AWWA C508
- NSF/ANSI 372-2011 Compliant
- Ductile Iron Body
- Meets MSS-SP-71
- Fusion bonded epoxy coating AWWA C550
- Flanged connection
- EPDM resilient disc
- Brass seat
- 4 boss design



Series 22FCW
Flanged Ductile Iron Swing Check Valve with Lever and Weight

- 300 lb. CWP
- Meets AWWA C508
- NSF/ANSI 372-2011 Compliant
- Ductile Iron Body
- Meets MSS-SP-71
- Fusion bonded epoxy coating AWWA C550
- Flanged connection
- EPDM resilient disc
- Brass seat
- 4 boss design



Size in	Part Number	Weight lb
	Flanged	
2	017322FC020	30
2-1/2	017322FC025	42
3	017322FC030	39
4	017322FC040	83
6	017322FC060	131
8	017322FC080	278
10	017322FC100	452
12	017322FC120	608

Size in	Part Number	Weight lb
	Flanged	
2	017322FCW020	43
2-1/2	017322FCW025	45
3	017322FCW030	58
4	017322FCW040	108
6	017322FCW060	154
8	017322FCW080	314
10	017322FCW100	368
12	017322FCW120	546

Spring Kits Available

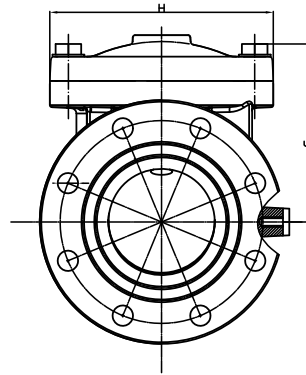
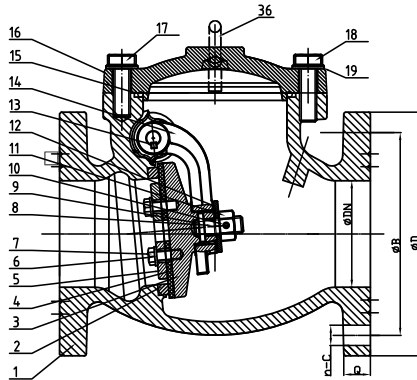

No.	Part	Material
1	Body	Ductile Iron ASTM A536 Class B
2	Body Seat Ring	Bronze, ASTM B62
3	Disc	Ductile Iron, Epoxy Coated
4	Disc Ring	EPDM
5	Disc Washer	Steel A307 Grade B
6	Disc Bolt/Washer	Stainless Steel, Type 304
7	Bolt/Pin/Nut/Washer	Stainless Steel, Type 304
8	Pin	Stainless Steel, Type 304
9	Key	Stainless Steel, Type 304
10	Cover O-Ring	EPDM
11	Cover Bolt/Washer	Steel A307 Grade B

No.	Part	Material
12	O-Ring	EPDM
13	Hinge Bolt	Stainless Steel, Type 304
14	Washer	Stainless Steel, Type 304
15	Cover	Ductile Iron, ASTM A536 Class B
16	Arm	Stainless Steel CF8

Series 100 & 101 Brass Boiler Drain

- 125 lb. CWP
- Cast brass
- Cast iron handle



Size in	Part Number		Packing		Weight lb
	Female	Male	Inner	Master	
1/2	0190100G	0190101G	14	84	0.5
3/4	0190100I	0190101I	14	84	0.5

Series 101X Brass Extended Shank Boiler Drain

- 125 lb. CWP
- Cast brass
- Extended shank model w/plastic locknut
- Cast iron handle



Size in	Part Number	Packing		Weight lb
	Male	Inner	Master	
1/2	0190101XG	12	72	0.5

Series 102 & 103 Brass Boiler Drain with Stuffing Box

- 125 lb. CWP
- Full flow
- Cast brass
- CSA Approved
- Certified to NSF/ANSI 61-8
- ISO 9001:2008 manufacturer



Size in	Part Number		Packing		Weight lb
	Female	Male	Inner	Master	
1/2	0190102G	0190103G	12	72	0.5
3/4	0190102I	0190103I	12	72	0.5

Series 106 Brass Boiler Drain, Compression Inlet

- 125 lb. CWP
- Cast brass
- Cast iron handle



Size in	Part Number	Packing		Weight lb
	Compression	Inner	Master	
1/2	0190106G	12	72	0.5

Series 180 Brass Evaporative Cooler Valve

- 125 lb. CWP
- Cast brass
- 1/8 NPT outlet tapped in side



Size in	Part Number	Packing		Weight lb
	Female	Inner	Master	
3/4	0190180I	14	84	0.5

Series 301 Brass Boiler Drain, 1/4 Turn

- 125 lb. CWP
- Lever/tee handle



Size in	Part Number	Packing		Weight lb
	Male	Inner	Master	
1/2	0190301G	12	72	0.5
3/4	0190301I	12	72	0.6

Note: Product contains brass which does not meet federal and state requirements for drinking water.



WARNING: Cancer and Reproductive Harm - www.P65Warnings.ca.gov

Series 132 & 142
Brass Straight Stop
with Stuffing Box

- 125 lb. CWP
- Cast brass
- CSA Approved
- Certified to NSF/ANSI 61-8
- ISO 9001:2008 manufacturer



Size in	Part Number		Packing		Weight lb
	Threaded	Sweat	Inner	Master	
1/2	0190132G	0190142G	14	84	0.6
3/4	0190132I	0190142I	14	84	0.6

Series 136 & 146
Brass Straight Stop
with Drain

- 125 lb. CWP
- Cast brass
- CSA Approved
- Certified to NSF/ANSI 61-8
- ISO 9001:2008 manufacturer



Size in	Part Number		Packing		Weight lb
	Threaded	Sweat	Inner	Master	
1/2	0190136G	0190146G	14	84	0.6
3/4	0190136I	0190146I	12	84	0.6

Series 164
Brass No Kink Hose Bibb,
MIP Inlet 1/4 Turn

- 125 lb. CWP
- Cast brass
- Red Butterfly handle
- ISO 9001:2008 manufacturer



Size in	Part Number	Ends Config.	Packing		Weight lb
			Inner	Master	
1/2	0190164G	Male	12	96	0.3
3/4	0190164I	Male	12	96	0.5

Series 361 & 362
Brass Hose Bibb,
1/4 Turn

- 125 lb. CWP
- Red Butterfly handle
- Cast brass
- ISO 9001:2008 manufacturer



Size in	Part Number		Packing		Weight lb
	Male	Female	Inner	Master	
1/2	0190361G	0190362G	12	72	0.48
3/4	0190361I	0190362I	12	72	0.53

Series 4101
Bronze Globe Valve

- 200 lb. CWP, 125 lb. WSP
- 85-5-5-5 bronze body
- Hard seat
- Conforms to MSS SP-80
- Brass stem and disc
- Cast iron handle
- ISO 9001:2008 manufacturer



Size in	Part Number	Packing		Weight lb
	Threaded	Inner	Master	
3/8	01764101E	10	100	0.6
1/2	01764101G	14	84	0.6
3/4	01764101I	10	60	0.7
1	01764101K	5	30	1.1
1-1/4	01764101L	4	32	1.9
1-1/2	01764101M	6	24	2.4
2	01764101N	4	16	3.6

Order On-Line
at www.smithcooper.com

Note: Product contains brass which does not meet federal and state requirements for drinking water.

WARNING: Cancer and Reproductive Harm - www.P65Warnings.ca.gov

Series 166 Brass Hose Bibb, MIP Inlet

- 125 lb. CWP
- Cast brass
- Heavy duty construction
- Green Tee handle
- Certified to NSF/ANSI 61-8
- ISO 9001:2008 manufacturer



Size in	Part Number	Packing		Weight lb
	Male	Inner	Master	
1/2	0190166G	10	60	0.6
3/4	0190166I	10	60	0.6

Series 167 Brass No Kink Hose Bibb, Compression Inlet

- 125 lb. CWP
- Cast brass
- Heavy duty construction
- Green Tee handle
- Certified to NSF/ANSI 61-8
- ISO 9001:2008 manufacturer



Size in	Part Number	Packing		Weight lb
	Compression	Inner	Master	
1/2	0190167G	15	90	0.5

Series 168 Brass No Kink Hose Bibb, FIP Inlet

- 125 lb. CWP
- Cast brass
- Heavy duty construction
- Green Tee handle
- Certified to NSF/ANSI 61-8
- ISO 9001:2008 manufacturer



Size in	Part Number	Packing		Weight lb
	Female	Inner	Master	
1/2	0190168G	15	90	0.4
3/4	0190168I	15	90	0.5

Series 169 Brass No Kink Hose Bibb, MIP Inlet

- 125 lb. CWP
- Cast brass
- Heavy duty construction
- Green Tee handle
- Certified to NSF/ANSI 61-8
- ISO 9001:2008 manufacturer



Size in	Part Number	Packing		Weight lb
	Male	Inner	Master	
1/2	0190169G	15	90	0.5
3/4	0190169I	15	90	0.5

Series 169IG Brass No Kink Hose Bibb, Sweat Inlet

- 125 lb. CWP
- Cast brass
- Heavy duty construction
- Green Tee handle
- Certified to NSF/ANSI 61-8
- ISO 9001:2008 manufacturer



Size in	Part Number	Packing		Weight lb
	Fem/Male SWT	Inner	Master	
3/4 x 1/2	0190169IG	15	90	0.5

Series 170 Brass Bent Nose Garden Valve, FIP Inlet

- 125 lb. CWP
- Cast brass
- Oval handle



Size in	Part Number	Packing		Weight lb
	Female	Inner	Master	
1/2	0190170G	12	72	0.7
3/4	0190170I	12	72	0.7
1	0190170K	12	72	0.7
1/2	0190170GLK*	12	72	0.6
3/4	0190170ILK*	12	72	0.7

*With Loose Key Handle

Note: Product contains brass which does not meet federal and state requirements for drinking water.



WARNING: Cancer and Reproductive Harm - www.P65Warnings.ca.gov

Series 159
Brass No Kink Hose Bibb,
Compression Inlet

- 125 lb. CWP
- Cast brass



Size in	Part Number	Packing		Weight lb
	Compression	Inner	Master	
1/2	0190159G	20	120	0.4

Series 160
Brass Hose Bibb,
MIP Inlet

- 125 lb. CWP
- Cast brass



Size in	Part Number	Packing		Weight lb
	Male	Inner	Master	
1/2	0190160G	15	90	0.4
3/4	0190160I	15	90	0.4

Series 161
Brass No Kink Hose Bibb,
MIP Inlet

- 125 lb. CWP
- Cast brass



Size in	Part Number	Packing		Weight lb
	Male	Inner	Master	
1/2	0190161G	20	120	0.3
3/4	0190161I	20	120	0.4

Series 162
Brass No Kink Hose Bibb,
FIP Inlet

- 125 lb. CWP
- Cast brass



Size in	Part Number	Packing		Weight lb
	Female	Inner	Master	
1/2	0190162G	20	120	0.3
3/4	0190162I	20	120	0.3

Series 163
Brass No Kink Hose Bibb,
Sweat Inlet

- 125 lb. CWP
- Cast brass



Size in	Part Number	Packing		Weight lb
	Fem/Male SWT	Inner	Master	
3/4 x 1/2	0190163IG	20	120	0.5

Series 0383
PTFE Tape (Virgin)

- Melting point 620°F (327°C)
- Thickness .0035 (±.0005)
- ISO 9001:2008 manufacturer
- ASTM Mil Spec T-27730A



Size in	Part Number	Length in	Packing		Weight lb
			Inner	Master	
1/2	0383260G	260	200	1200	0.1
3/4	0383260I	260	150	600	0.1
1/2	0383520G	520	200	1200	0.1
3/4	0383520I	520	150	600	0.1
1	0383260K	260	150	600	0.1
1/2 (yellow)	0383260GY	260	100	600	0.1

Note: Product contains brass which does not meet federal and state requirements for drinking water.

WARNING: Cancer and Reproductive Harm - www.P65Warnings.ca.gov

Series 400 Frost Free Sillcock

- 3/4 MHT outlet
- 1/2 MIP x 1/2 SWT inlet
- Brass body
- Chrome plated



Length in	Part Number	Packing		Weight lb
	1/2 MIP x 1/2 SWT	Inner	Master	
4	0190404GG	2	48	0.9
6	0190406GG	2	48	1.0
8	0190408GG	2	48	1.0
10	0190410GG	2	48	1.1
12	0190412GG	2	48	1.2

Series 500 Frost Free Sillcock

- 3/4 MHT outlet
- 3/4 MIP x 1/2 FIP inlet
- Brass body
- Chrome plated



Length in	Part Number	Packing		Weight lb
	3/4 MIP x 1/2 FIP	Inner	Master	
4	0190504IG	2	48	1.0
6	0190506IG	2	48	1.0
8	0190508IG	2	48	1.1
10	0190510IG	2	48	1.1
12	0190512IG	2	24	1.2
14	0190514IG	2	24	1.3

Series 700 Anti-Siphon Frost Free Sillcock

- 3/4 MHT outlet
- 1/2 MIP x 1/2 SWT inlet
- Chrome plated brass body with vacuum breaker
- Metal handle (plastic handle available)
- IAPMO/UPC Listed
- CSA Approved
- ASSE Approved
- ISO 9001:2008 manufacturer



Length in	Part Number	Packing		Weight lb
	1/2 MIP x 1/2 SWT	Inner	Master	
4	0190704GG	2	24	1.0
6	0190706GG	2	24	1.1
8	0190708GG	2	24	1.1
10	0190710GG	2	24	1.2
12	0190712GG	2	24	1.3
14	0190714GG	2	24	1.3

Series 800 Anti-Siphon Frost Free Sillcock

- 3/4 MHT outlet
- 3/4 MIP x 1/2 FIP inlet
- Chrome plated brass body with vacuum breaker
- Metal handle (plastic handle available)
- IAPMO/UPC Listed
- CSA Approved
- ASSE Approved
- ISO 9001:2008 manufacturer



Length in	Part Number	Packing		Weight lb
	3/4 MIP x 1/2 FIP	Inner	Master	
4	0190804IG	2	48	1.1
6	0190806IG	2	24	1.1
8	0190808IG	2	24	1.2
10	0190810IG	2	24	1.2
12	0190812IG	2	24	1.2
14	0190814IG	2	24	1.3

Note: Product contains brass which does not meet federal and state requirements for drinking water.



WARNING: Cancer and Reproductive Harm - www.P65Warnings.ca.gov

Series 112VB
Brass Flanged Sillcock with
Stuffing Box & Vacuum Breaker,
FIP Inlet

- 125 lb. CWP
- Cast brass
- Hose end vacuum breaker installed
- Certified to NSF/ANSI 61-8
- Vacuum breaker meets ANSI 10.11 and CSA B64.2
- ISO 9001:2008 manufacturer



Size in	Part Number	Packing		Weight lb
		Inner	Master	
1/2	0190112GVB	8	48	0.8

Series 112
Brass Flanged Sillcock with
Stuffing Box, FIP Inlet

- 125 lb. CWP
- Cast brass
- Certified to NSF/ANSI 61-8
- ISO 9001:2008 manufacturer



Size in	Part Number	Packing		Weight lb
		Inner	Master	
1/2	0190112G	10	60	0.6
3/4	0190112I	8	48	0.6

Series 167
Vacuum Breaker

- FHT x MHT
- ASSE/UPC Approved and Marked
- Flat sealing washer
- Break away locking screw



Size in	Part Number	Packing		Weight lb
		Inner	Master	
3/4	0190167II	48	288	0.2

Series 310
Brass Flanged Sillcock,
FIP Inlet 1/4 Turn

- Red Butterfly Handle
- Brass Body
- ISO 9001:2008 manufacturer



Size in	Part Number	Packing		Weight lb
		Inner	Master	
1/2	0190310G	12	72	0.5
3/4	0190310I	12	72	0.6

Series 110 & 111
Brass Flanged Sillcock
FIP or Sweat Inlet

- 125 lb. CWP
- Cast brass



Size in	Part Number	Connection	Packing		Weight lb
			Inner	Master	
1/2	0190110G	Female	12	72	0.5
3/4	0190110I	Female	12	72	0.5
1/2 x 3/4	0190111GI	Sweat	12	72	0.5

Series 7200
Ground Key Stop & Drain

- Max 150 psi @ 100°F



Size in	Part Number	Packing		Weight lb
		Inner	Master	
1/2	01767200G	6	48	.9
3/4	01767200I	6	48	1.0
1	01767200K	4	32	2.0

Note: Product contains brass which does not meet federal and state requirements for drinking water.

WARNING: Cancer and Reproductive Harm - www.P65Warnings.ca.gov

Series 9121 & 9122 PVC Ball Valve

- Schedule 40/80 PVC
- 150 psi @ 73°F
- Molded-in-place construction
- White w/blue handle
- EPDM O-ring stem seal
- Santoprene seat



Size in	Part Number		Packing		Weight lb
	Threaded	Slip	Inner	Master	
1/2	02939121G	02939122G	24	96	0.2
3/4	02939121I	02939122I	18	72	0.2
1	02939121K	02939122K	20	80	0.4
1-1/4	02939121L	02939122L	20	40	0.5
1-1/2	02939121M	02939122M	14	28	0.8
2	02939121N	02939122N	5	20	1.4
2-1/2	02939121P	02939122P	-	12	3.7
3	02939121Q	02939122Q	-	8	5.6
4	02939121T	02939122T	-	3	6.3

Series 9541 & 9542 PVC Ball Valve

- Certified to NSF/ANSI 14
- Schedule 40/80 PVC
- 150 psi @ 73°F
- PTFE seat
- EPDM O-ring stem seal
- Molded-in-place construction
- Gray w/blue handle
- Produced using virgin PVC resins



Size in	Part Number		Packing		Weight lb
	Threaded	Slip	Inner	Master	
1/2	02939541G	02939542G	24	96	0.2
3/4	02939541I	02939542I	18	72	0.2
1	02939541K	02939542K	20	80	0.4
1-1/4	02939541L	02939542L	20	40	0.5
1-1/2	02939541M	02939542M	14	28	0.8
2	02939541N	02939542N	5	20	1.4

Series 9521 & 9522 PVC Ball Valve

- Certified to NSF/ANSI 14
- Schedule 40/80 PVC
- 150 psi @ 73°F
- PTFE seat
- EPDM O-ring stem seal
- Molded-in-place construction
- White w/blue handle
- Produced using virgin PVC resins



Size in	Part Number		Packing		Weight lb
	Threaded	Slip	Inner	Master	
1/2	02939521G	02939522G	24	96	0.2
3/4	02939521I	02939522I	18	72	0.3
1	02939521K	02939522K	20	80	0.6
1-1/4	02939521L	02939522L	20	40	0.7
1-1/2	02939521M	02939522M	14	28	1.0
2	02939521N	02939522N	5	20	1.5

Series 6122 CPVC Ball Valve, CTS Slip

- Certified to NSF/ANSI 14
- Copper Tube Size
- 150 psi @ 180°F
- PTFE seat
- EPDM O-ring stem seal
- Cream body w/red handle
- Produced using virgin CPVC resins



Size in	Part Number	Packing		Weight lb
	Slip	Inner	Master	
1/2	02936122G	45	180	0.1
3/4	02936122I	25	100	0.2
1	02936122K	18	72	0.4

Series CV40 & CV50 PVC In-Line Check Valve

- 150 psi @ 73°F
- Schedule 40 PVC
- EPDM seal
- Spring loaded, stainless steel spring, opens at 2 psi



Size in	Part Number		Packing		Weight lb
	Threaded	Slip	Inner	Master	
1/2	0209CV40G	0209CV50G	12	144	0.2
3/4	0209CV40I	0209CV50I	6	72	0.2
1	0209CV40K	0209CV50K	6	60	0.4
1-1/4	0209CV40L	0209CV50L	4	48	0.6
1-1/2	0209CV40M	0209CV50M	4	40	0.9
2	0209CV40N	0209CV50N	4	24	2.0



Series 7161
Celcon No Kink Hose Bibb
• Max 150 psi @ -20°F to +180°F

Size in	Part Number	Packing		Weight lb
	MIP x MHT	Inner	Master	
1/2	0227161G	-	108	0.2
3/4	0227161I	-	108	0.2



Series 7160
Celcon Hose Bibb
• Max 150 psi @ -20°F to +180°F

Size in	Part Number	Packing		Weight lb
	MIP x MHT	Inner	Master	
1/2	0227160G	12	108	0.2
3/4	0227160I	12	108	0.2



Series 7101 & 7102
Celcon Boiler Drain
• Max 150 psi @ -20°F to +180°F

Size in	Part Number		Packing		Weight lb
	Threaded	Slip	Inner	Master	
1/2	0227101G	0227102G	12	108	0.2
3/4	0227101I	0227102I	12	108	0.2



Series 7130
Celcon Straight Stop Valve
• Max 150 psi @ -20°F to +180°F

Size in	Part Number	Packing		Weight lb
	Threaded	Inner	Master	
1/2	0227130G	12	108	0.2
3/4	0227130I	12	108	0.2



Series 8135
CPVC Straight Stop Valve with Drain
• Max 100 psi @ 100°F

Size in	Part Number	Packing		Weight lb
	Slip x Slip	Inner	Master	
1/2	0228135G	-	108	0.2



Series 8130
CPVC Straight Stop Valve
• Max 100 psi @ 100°F

Size in	Part Number	Packing		Weight lb
	Slip x Slip	Inner	Master	
1/2	0228130G	12	108	0.2
3/4	0228130I	12	108	0.2



Series 6130
PVC Straight Stop Valve
• Max 100 psi @ 73°F

Size in	Part Number	Packing		Weight lb
	Slip x Slip	Inner	Master	
1/2	0226130G	12	108	0.2
3/4	0226130I	12	108	0.2