

L/LS/GA

Reinforcing and Skewable Angles

L — Staggered nail pattern reduces the possibility for splitting.

LS — Field-adjustable 0° to 135° angles. The GA gusset angles' embossed bend section provides added strength.

Material: L — 16 gauge; GA and LS — 18 gauge

Finish: Galvanized. Some products available in stainless steel or ZMAX® coating. See Corrosion Information, pp. 13–15.

Installation:

- Use all specified fasteners; see General Notes
- LS — Field skewable; bend one time only
- Joist must be constrained against rotation (for example, with solid blocking) when using a single LS per connection
- Nail the L angle's wider leg into the joist to ensure table loads and allow correct nailing

Codes: See p. 12 for Code Reference Key Chart

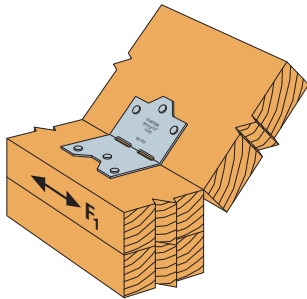
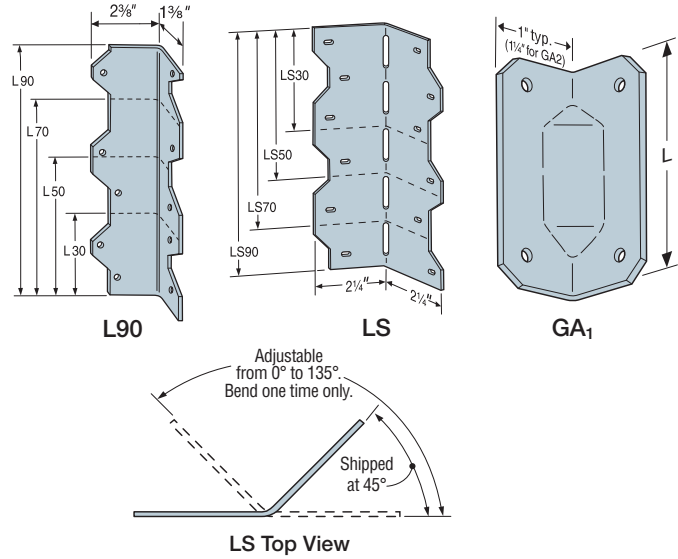

Typical LS30 Installation

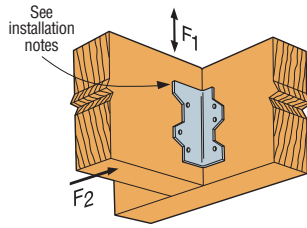

Typical L50 Installation

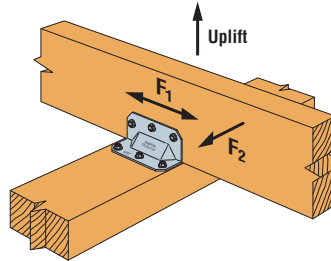

Typical GA Installation

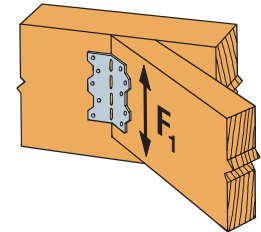

Typical LS70 Installation

These products are available with additional corrosion protection. For more information, see p. 15.

SS For stainless-steel fasteners, see p. 21.

SD Many of these products are approved for installation with Strong-Drive® SD Connector screws. See pp. 335–337 for more information.

Model No.	Fasteners (in.)	L (in.)	Load Direction	DF/SP Allowable Loads				SPF/HF Allowable Loads				Code Ref.
				Floor (100)	Snow (115)	Roof (125)	Wind/Seismic (160)	Floor (100)	Snow (115)	Roof (125)	Wind/Seismic (160)	
GA1	(4) 0.148 x 1 1/2	2 3/4	F ₁ , F ₂	235	270	290	350	200	230	250	300	IBC, FL, LA
	(4) SD #9 x 1 1/2		F ₁	340	375	375	375	225	260	280	325	
	(4) SD #9 x 1 1/2		F ₂	340	395	430	435	225	260	280	360	
GA2	(6) 0.148 x 1 1/2	3 1/4	F ₁ , F ₂	355	405	435	550	305	350	375	475	IBC, FL, LA
	(6) SD #9 x 1 1/2		F ₁	515	590	640	695	335	385	420	600	
	(6) SD #9 x 1 1/2		F ₂	515	590	640	820	335	385	420	540	
L30	(4) 0.148 x 1 1/2	3	F ₁	245	250	250	250	210	215	215	215	IBC, FL, LA
			F ₂	245	275	295	370	210	235	255	320	
L50	(6) 0.148 x 1 1/2	5	F ₁	365	415	445	525	315	355	385	450	IBC, FL, LA
			F ₂	365	415	445	555	315	355	385	475	
L70	(8) 0.148 x 1 1/2	7	F ₁ , F ₂	485	550	595	740	415	475	510	635	IBC, FL, LA
L90	(10) 0.148 x 1 1/2	9	F ₁ , F ₂	610	690	740	925	525	595	635	795	
LS30	(6) 0.148 x 1 1/2	3%	F ₁	320	320	320	320	275	275	275	275	IBC, FL, LA
	(6) 0.148 x 3		F ₁	355	395	395	395	305	340	340	340	
SS LS50	(8) 0.148 x 1 1/2	4 7/8	F ₁	475	540	560	560	410	465	480	480	IBC, FL, LA
	(8) 0.148 x 3		F ₁	475	540	580	730	410	465	500	630	
LS70	(10) 0.148 x 1 1/2	6 3/8	F ₁	590	645	645	645	510	555	555	555	IBC, FL, LA
	(10) 0.148 x 3		F ₁	590	675	725	915	510	580	625	785	
LS90	(12) 0.148 x 1 1/2	7 7/8	F ₁	710	805	870	890	610	690	750	765	IBC, FL, LA
	(12) 0.148 x 3		F ₁	710	805	870	1,040	610	690	750	895	

1. GA angles may be installed with 0.148" x 3" nails.
 2. GA1 uplift is 425 lb. for DF and 300 lb. for SPF when installed with Strong-Tie® SD Connector screws.
 3. GA2 uplift is 370 lb. for DF and 260 lb. for SPF when installed with Strong-Tie® SD Connector screws.
 4. **Fasteners:** Nail dimensions in the table are listed diameter by length. SD screws are Simpson Strong-Tie® Strong-Drive® screws. See pp. 21–22 for fastener information.