

PCZ/EPCZ

Post Caps

PCZ/EPCZ post caps are designed with their post and beam flanges in-line so that one PCZ/EPCZ model can accommodate several post sizes. The PCZ/EPCZ uses 0.148" x 3" nails. An alternate choice of fastener is the #9 x 1 1/2" Strong-Drive® SD Connector screw. ZMAX® finish is standard to meet exposure conditions in many environments. See additional corrosion information at strongtie.com/info.

Material: 16 gauge

Finish: ZMAX coating

Installation:

- Use all specified fasteners; see General Notes
- Do not install bolts into pilot holes

Options:

- For end conditions, specify EPCZ post caps
- For heavy-duty applications, see CCQ and CC Series
- For retrofit applications, see AC and LCE Series

Codes: See p. 12 for Code Reference Key Chart

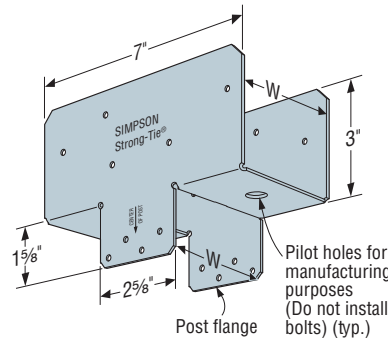

PCZ

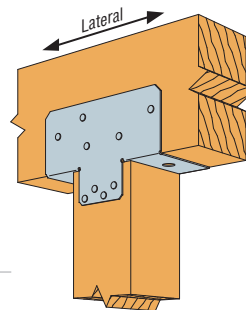

Typical PCZ Post Cap Installation

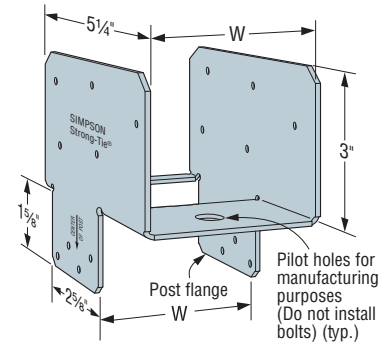

EPCZ

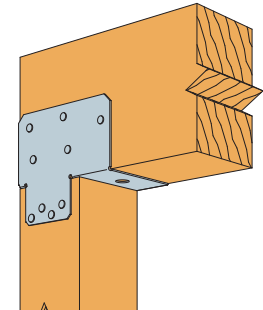

Typical EPCZ End Post Cap Installation

These products are available with additional corrosion protection. For more information, see p. 15.

SD Many of these products are approved for installation with Strong-Drive® SD Connector screws. See pp. 335–337 for more information.

Model No.	W (in.)	Fasteners (in.)		Post Size	Allowable Loads (DF/SP)				Code Ref.
		Beam	Post		PCZ		EPCZ		
					Uplift (160)	Lateral (160)	Uplift (160)	Lateral (160)	
PC4Z	3 3/16	(10) 0.148 x 3	(8) 0.148 x 3	(2) 2x4	1,480	1,120	1,130	895	IBC, FL, LA
				4x4	1,480	1,260	1,130	1,075	
				4x6	1,480	1,260	1,130	1,230	
				4x8	1,480	1,380	1,130	1,230	
PC6Z	5 1/2	(10) 0.148 x 3	(8) 0.148 x 3	4x6	1,480	1,260	1,435	1,075	
				6x6	1,480	1,295	1,435	1,230	
				6x8	1,480	1,380	1,435	1,230	
PC8Z	7 1/2	(10) 0.148 x 3	(8) 0.148 x 3	4x8	1,480	1,260	1,435	1,075	
				6x8	1,480	1,295	1,435	1,230	
				8x8	1,480	1,380	1,435	1,230	

1. Allowable loads have been increased for wind or earthquake loading with no further increase allowed. Reduce where other loads govern.
2. Uplift loads do not apply to spliced conditions. Spliced conditions must be detailed by the Designer to transfer tension loads between spliced members by means other than the post cap.
3. Structural composite lumber columns have sides that show either the wide face or the edges of the lumber strands/veneers known as the narrow face. Values in the tables reflect installation into the wide face. See technical bulletin T-C-SCLCLM at strongtie.com for load reductions resulting from narrow-face installations.
4. Post and beam may consist of multiple members provided they are connected independently of the post cap fasteners.
5. 0.148" x 2 1/2" nails may be used with no load reduction for uplift and 0.85 of the table loads for lateral.
6. #9 x 1 1/2" Strong-Drive® SD Connector screws may be substituted for table fasteners with no load reduction.
7. To order models available for rough size lumber, specify RZ suffix — e.g., PC4RZ.
8. **Fasteners:** Nail dimensions in the table are diameter by length. See pp. 21–22 for fastener information.

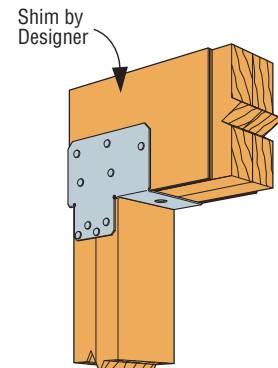

EPCZ Post Cap Installed on Double 2x Members

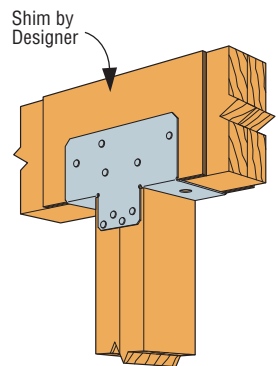

PCZ Post Cap Installed on Double 2x Members