

Installation Options for Deck Lateral Load Connections



Background

When decks are supported by attachment to the primary structure, the International Residential Code® (2000 through 2018 IRC) requires a positive attachment to that building to resist lateral loads. These loads can result from wind or seismic forces acting on a deck or from movements of the deck's occupants. If the band joist, deck ledger or deck joists were to pull away from the primary structure as a result of lateral forces, the deck would not be supported for gravity (vertical) loads and would likely collapse (see Figure 1).

To help builders achieve proper attachment, an approved method was added to the 2009 IRC to resist lateral loads by using holdown devices with a minimum allowable load of 1,500 lb. in at least two locations per deck. The 1,500 lb. holdowns connect a deck joist to a floor joist in the supporting structure that is nailed to the floor sheathing above (see Figure 2). The 2015 IRC added a second approved method that permits a holdown with an allowable load of 750 lb. in at least four locations per deck to fasten the deck joists to the top plate, studs or headers within the supporting structure using a fully threaded 3/8" lag screw (see Figure 3). This new option allows a positive attachment for the deck that is ideal when the house joists are inaccessible.

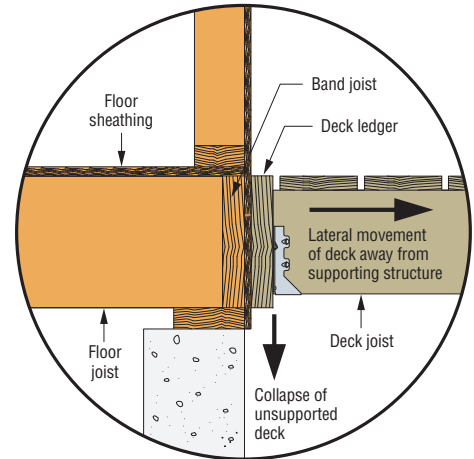

Figure 1

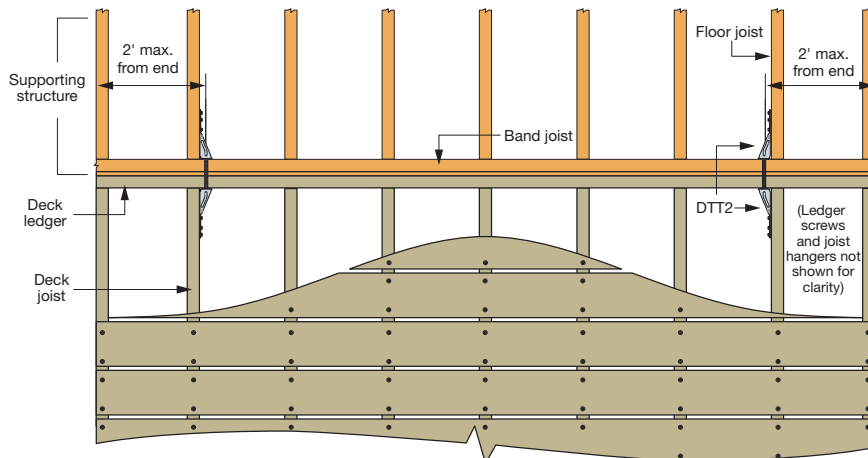

Figure 2 (1,500 lb. requirement)

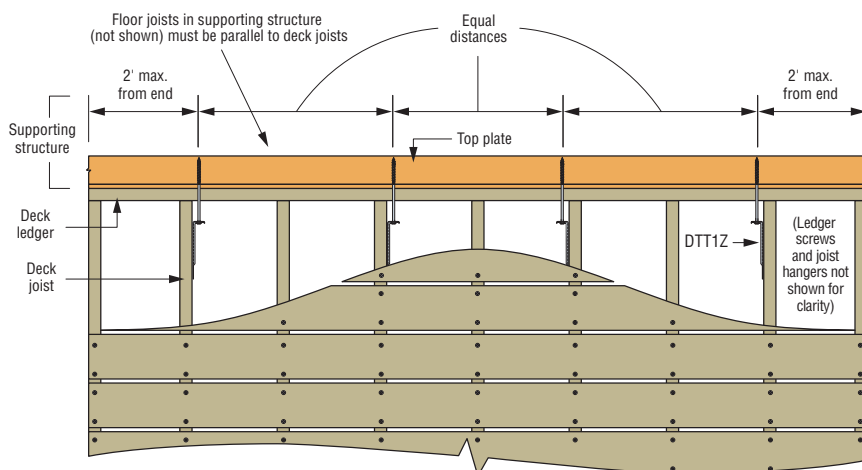

Figure 3 (750 lb. requirement)

The Simpson Strong-Tie® DTT1Z and DTT2 deck tension ties have been developed to provide versatile and cost-effective solutions for these critical connections. The DTT1Z is supplied with a ZMAX® coating; the DTT2 is available in ZMAX (DTT2Z) or stainless steel (DTT2SS).

The DTT2 satisfies the 1,500 lb. requirement and is installed in pairs. The DTT2 fastens to the wide face of the deck and house joists with Strong-Drive® SDS Heavy-Duty Connector screws (included), and the pair is anchored together with a 1/2" threaded rod (washers included).

The DTT1Z satisfies the 750 lb. requirement and fastens to the narrow or wide face of the deck joist with Strong-Drive SD Connector screws or nails and attaches to the supporting structure with a fully threaded 3/8" lag screw and washer (not included) or a Strong-Drive SDWH Timber-Hex HDG screw with an integral washer.



Installation Options for Deck Lateral Load Connections

Allowable Loads

Model No.	℄	Anchor Diameter or Type	Fasteners	Allowable Tension Load (lb.) (160)			
				Dry		Wet	
				DF/SP	SPF/HF	DF/SP	SPF/HF
DTT1Z	3/4"	3/8" or SDWH ⁶	(6) SD #9 x 1 1/2"	840	840	840	755
			(6) 10d x 1 1/2"	910	640 ⁴	795	640 ⁴
			(8) 10d x 1 1/2"	910	850	910	850
DTT2Z/DTT2SS	13/16"	1/2"	(8) SDS 1/4" x 1 1/2"	1,825	1,800	1,825	1,615

1. Allowable loads have been increased 60% for short-term loading with no further increase allowed.
2. Dry values are applicable to installations into wood with a moisture content that does not exceed 19%.
3. Wet values are applicable to installations into wood with a moisture content greater than 19% at time of installation or in service. Values include an NDS wet service factor for the fasteners.
4. DTT1Z installations with allowable loads below 750 lb. do not satisfy the 2015/2018 IRC requirements for deck-to-house lateral load connections.
5. DTT1Z installed with the Strong-Drive® SDWH Timber-Hex HDG screw with a min. of 3" thread penetration achieves the lesser of the table load or 855 lb. SDWH installed with 3" of thread penetration into dry lumber has an allowable withdrawal load (160) of 1,380 lb. into SP, 1,225 lb. into DF and 1,020 lb. into SPF/HF.
6. Load values are valid if the product is flush with the end of the framing member or installed away from the end from the end.
7. Fasteners: SD #9 x 1 1/2" (model SD9112) = 0.131" dia. x 1 1/2", 10d x 1 1/2" = 0.148" dia. x 1 1/2" long.

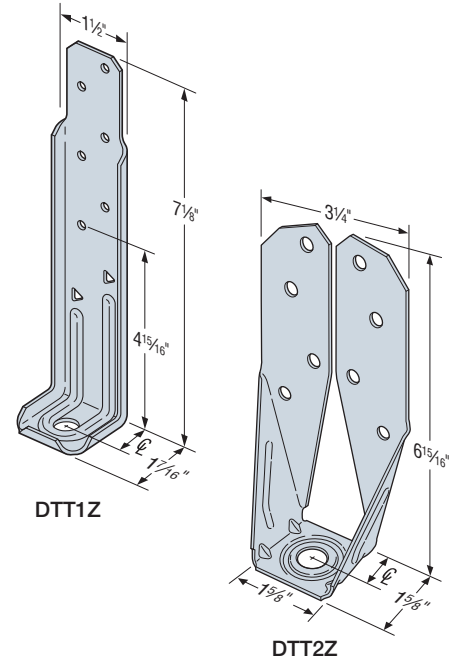

Conditions Not Shown in the IRC

The IRC details describe particular methods that are approved and do not represent all common framing conditions. When these are encountered, alternate methods of construction may need to be approved by the building official to ensure they satisfy the intent of the code and are at least equivalent to the prescribed method. Several alternate construction methods are shown here.

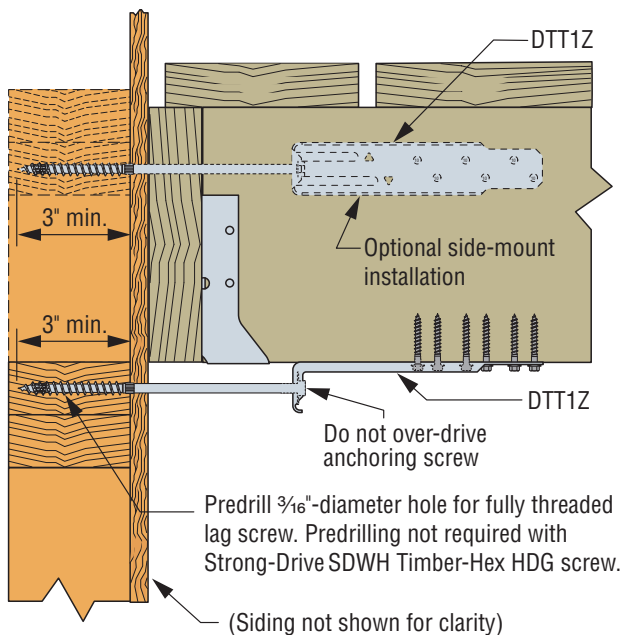

Figure 4

DTT1Z — 750 lb. Assembly

Condition 1 — Holdown Cannot Be Installed Flush with Wall Sheathing

Unlike some holdowns, the DTT1Z seat is not required to bear on sheathing or framing and can be installed away from the wall to account for non-structural siding, joist hanger interference or other conditions. Longer screw anchors may be required to ensure a minimum of 3" thread penetration by a fully threaded lag screw or Strong-Drive SDWH Timber-Hex HDG screw into the wall framing.

Condition 2 — Top of Wall Plate Does Not Align with Bottom of Deck Joist

The 2015/2018 IRC detail shows a holdown installed on the bottom of the joist. However, the DTT1Z was tested and developed using 1 1/2" fasteners into either the narrow edge or wide face of a 2x member, allowing the DTT1Z to be installed at any location along the depth of the joist.

Installation Options for Deck Lateral Load Connections

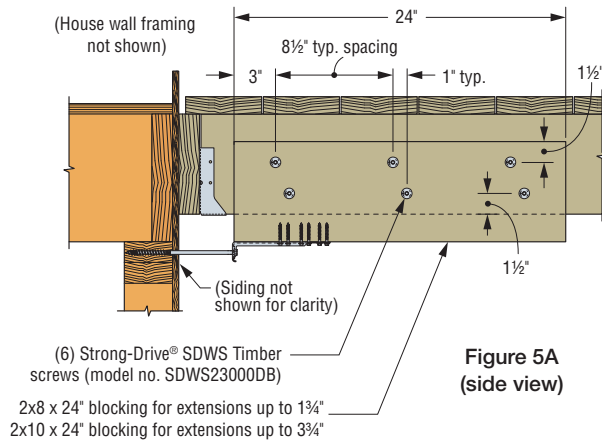

Figure 5A
(side view)

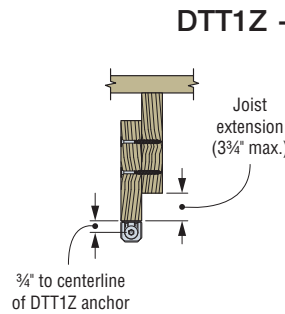

Figure 5B
(end view)

DTT1Z — 750 lb. Assembly (cont.)

Condition 3 — Wall Plate Is Below Bottom of Deck Joist

The DTT1Z has been tested with the blocking assembly shown in Figures 5A and 5B, which allows the holddown to be lowered up to 3 3/4" below the bottom of the deck joist in order to anchor into the center of a wall plate.

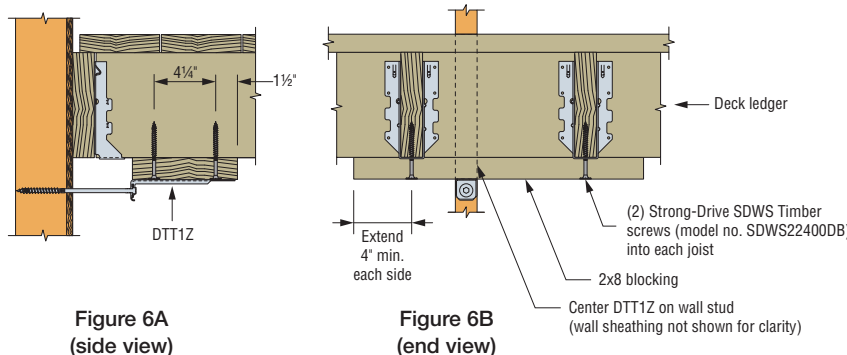

Figure 6A
(side view)

Figure 6B
(end view)

Condition 4 — Wall Stud Receiving Anchor Does Not Align with Deck Joist

The DTT1Z may be positioned on horizontal 2x8 blocking that can be installed between two deck joists, as shown in Figures 6A and 6B. This allows the holddown to be centered on a wall stud that does not align with a deck joist. Alternatively, an additional deck joist can be added to the deck to align with a wall stud (not shown).

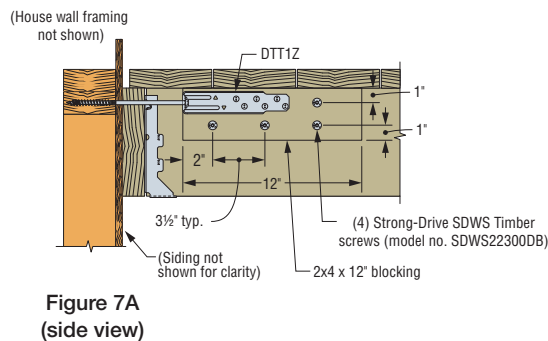

Figure 7A
(side view)

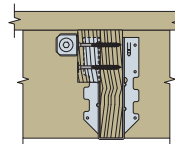

Figure 7B
(end view)

Condition 5 — Joist Hanger Flanges Interfere with Screw Anchor

In some cases it may be necessary to position the DTT1Z in a location that conflicts with a joist hanger or other obstruction. Figures 7A and 7B detail an assembly that allows the DTT1Z to be installed 1 1/2" away from the face of the deck joist.

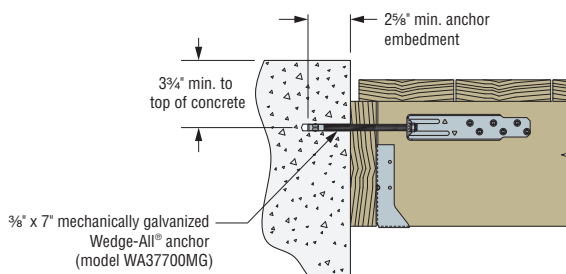

Figure 8

Condition 6 — Ledger Attaches to Concrete Foundation Wall

As an alternative to using a Strong-Drive SDWH Timber-Hex HDG screw or fully threaded 3/8" lag screw, the DTT1Z may be anchored with a 3/8" mechanically galvanized Wedge-All® anchor (as shown in Figure 8) to achieve the 750 lb. load requirement.

Condition 7 — Floor Joist Framing Is Perpendicular to the Deck Joist (Not Shown)

The IRC states that the 750 lb. holddown detail is "applicable where the floor joists are parallel to deck joists." For floor joists perpendicular to deck joists, refer to Condition 2 for the DTT2 — 1,500 lb. Assembly on the next page.

Installation Options for Deck Lateral Load Connections



DTT2 — 1,500 lb. Assembly

Condition 1 — Floor Joist Framing Does Not Line Up with the Deck Joist (Figure 9)

The DTT2 may be installed with a maximum allowable offset of 1½" when the ties are installed at least 18" apart (see Figure 9). Larger offsets may require an additional deck joist be added to line up with the floor joist.

Condition 2 — Floor Joist Framing Is Perpendicular to the Deck Joist (Figure 10)

Full-height blocking between joists is a common construction method when lateral load is applied perpendicular to floor framing. The blocking for this application would have to extend into the floor framing far enough to permit enough fasteners from the floor sheathing to transfer 1,500 lb. A 0.131" x 2½" nail through 2¾" wood structural-panel floor sheathing (G = 0.50) into SPF or better blocking (G ≥ 0.42) has an allowable lateral design value of 131 lb. (1.60 load duration factor*). This installation would require 12 nails through the floor sheathing into the blocking. It is recommended that the blocking extend into the floor at least two joist bays and the DTT2 be installed in the farthest blocked bay (see Figure 10). When nails into the floor sheathing cannot be installed, see Condition 5 below.

*A load duration factor of 1.60 corresponds to a 10-minute duration of maximum load; adjust for other durations.

Condition 3 — Floor Joist Is a Wood Truss or I-Joist

The DTT2 must be installed on a minimum 2x wood member. Some wood truss and I-joist manufacturers have developed details to attach a horizontal 2x member to their product to transfer a 1,500 lb. lateral load. Contact the manufacturer of the engineered floor component for more information.

Condition 4 — Top of Deck Steps Down Below Top of Floor (Figure 11 and 12)

The DTT2 may be installed with as little as 4" of vertical overlap between the floor joist and deck joist depths. Note that the code-prescribed connection between the deck ledger and band joist to support gravity loads will require much more overlap. When a step down results in a deck ledger that is attached to a concrete or grout-filled CMU foundation wall, the DTT2 may attach to a ½"-diameter anchor rod that is attached to the wall (ledgers are not permitted to be supported by stone or masonry veneer). The anchorage and the wall should be designed to support a 1,500 lb. lateral load (see Figures 11 and 12).

Condition 5 — No Access to the Top of the Floor Sheathing (Figure 13)

When the floor sheathing-to-joist nailing specified in the IRC cannot be installed, an alternate connection capable of transferring 1,500 lb. to the floor sheathing is required. Simpson Strong-Tie has evaluated the A35 framing angle installed in ½" minimum plywood or OSB sheathing with PH612I #6 x ½" pan-head screw.* The installation shown in Figure 13 has an allowable lateral load of 425 lb. per A35 (based on a 3.0 factor of safety). Use four A35 framing angles to meet the 1,500 lb. requirement. When fastened to full-height blocking (see Condition 2), use at least two A35 framing angles on each block.

*Available from Simpson Strong-Tie® in 200-count boxes, model number PH612IR200.

Condition 6 — No Access to Floor Joist

When there is no access to the floor joists in the primary structure, the DTT1Z 750 lb. assembly (as shown in this technical bulletin) offers an easy-to-install solution. Where a positive connection to the primary structure cannot be made or verified during inspection, the IRC requires the deck to be self-supporting.

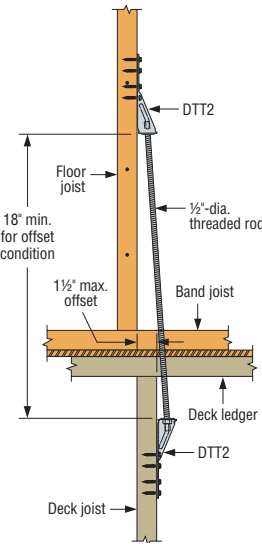

Figure 9

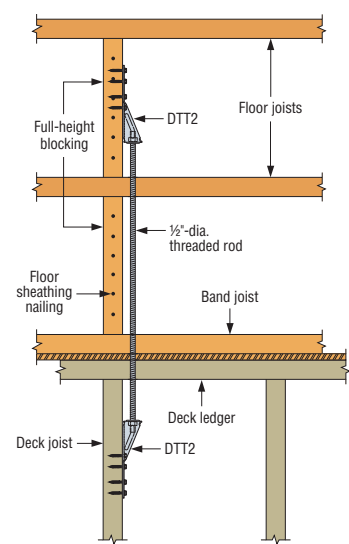

Figure 10

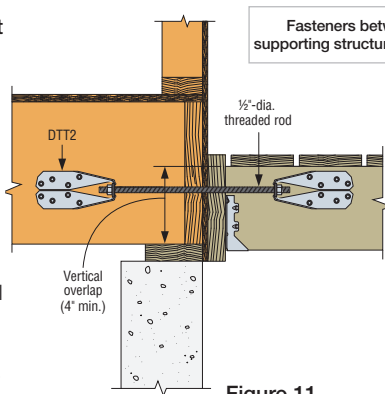

Figure 11

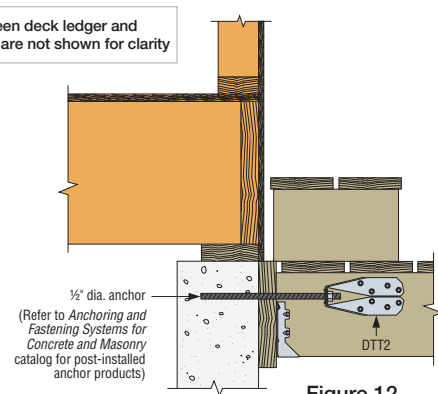

Figure 12

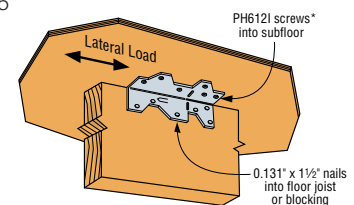

Figure 13