

STIHL MS 210, 230, 250

2003-04

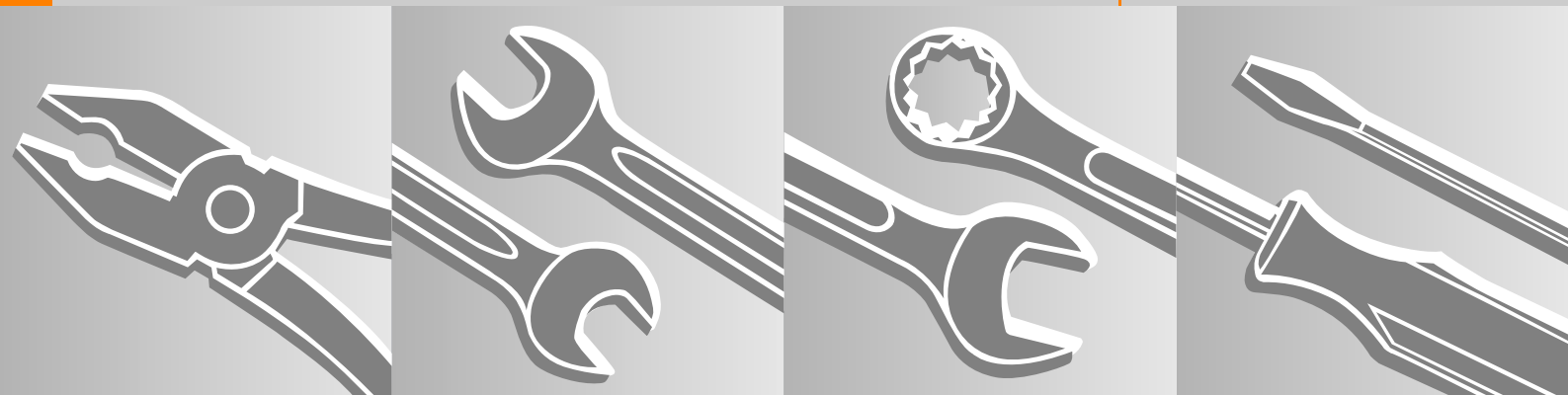

Contents

1.	Introduction	2	6.	Engine	23	10.	Chain Lubrication	54
			6.1	Muffler/Spark Arresting Screen	23	10.1	Pickup Body	54
2.	Safety Precautions	3	6.2	Leakage Test	24	10.2	Connector/ Suction Hose	55
			6.2.1	Preparations	24	10.3	Valve	55
3.	Specifications	4	6.2.2	Pressure Test	25	10.4	Worm	56
3.1	Engine	4	6.2.3	Vacuum Test	26	10.5	Oil Pump	57
3.1.1	Engine (USA only)	4	6.3	Oil Seals	26			
3.2	Fuel System	5	6.4	Removing and Installing	28	11.	Fuel System	58
3.3	Ignition System	5	6.5	Cylinder	29	11.1	Air Filter	58
3.4	Chain Lubrication	5	6.6	Piston	31	11.2	Carburetor	59
3.5	Tightening Torques	6	6.7	Piston Rings	33	11.2.1	Leakage Test	59
			6.8	Crankshaft	33	11.2.2	Removing and Installing	60
4.	Troubleshooting Chart	8	6.9	Decompression Valve	34	11.2.3	Adjusting (Carburetor without Limiter Cap)	61
4.1	Clutch, Chain Drive, Chain Brake, Chain Tensioner	8	7.	Ignition System	34	11.2.4	Adjusting (Carburetor with Limiter Cap)	62
4.2	Rewind Starter	9	7.1	Spark Plug Boot	35	11.2.5	Standard Setting (Carburetor with Limiter Cap)	62
4.3	Chain Lubrication	10	7.2	Ignition Module	35	11.3	Tank Vent	63
4.4	Ignition System	11	7.3	Testing the Ignition Coil	36	11.4	Pickup Body	64
4.5	Carburetor	12	7.4	Checking the Wiring Harness	36	11.5	Suction Hose	64
4.6	Engine	14	7.4.1	Ignition Timing	37	11.6	Manual Fuel Pump	65
			7.4.2	Removing and Installing	37	11.7	Hoses	65
5.	Clutch, Chain Drive, Chain Brake and Chain Tensioner	15	7.5	Flywheel	38	11.8	Fuel Tank	67
5.1	Clutch Drum / Chain Sprocket	15	7.6	Ignition System Troubleshooting	39			
5.2	Chain Catcher	16	8.	Rewind Starter	42	12.	Special Servicing Tools	69
5.3	Clutch	16	8.1	General	42			
5.4	Chain Brake	18	8.2	Removing and Installing	42	13.	Servicing Aids	71
5.4.1	Checking Operation	18	8.3	Rope Rotor	42			
5.4.2	Removing	19	8.4	Segment	44			
5.4.3	Installing	20	8.5	Starter Rope	44			
5.5	Front Chain Tensioner	22	8.5.1	Elastostart	45			
5.6	Side Chain Tensioner	22	8.5.2	Tensioning	46			
			8.6	Rewind Spring	47			
			8.7	Pawl	48			
			9.	AV Handle System/ Handle Housing	48			
			9.1	Annular Buffers	48			
			9.2	Front Handle	49			
			9.3	Handle Housing	50			
			9.4	Switch Shaft	52			
			9.5	Contact Spring	52			
			9.6	Throttle Trigger/ Interlock Lever	53			

STIHL[®]

© ANDREAS STIHL AG & Co. KG, 2007

1. Introduction

This service manual contains detailed descriptions of all the repair and servicing procedures specific to this power tool series.

As the design concept of model MS 210, 230 and 250 chainsaws is almost identical, the descriptions and servicing procedures in this manual generally apply to all three models. Differences are described in detail.

You should make use of the illustrated parts lists while carrying out repair work. They show the installed positions of the individual components and assemblies.

Refer to the latest edition of the relevant parts list to check the part numbers of any replacement parts.

A fault on the machine may have several causes. To help locate the fault, consult the troubleshooting charts for all assemblies and systems in this manual and the "STIHL Service Training System".

Refer to the "Technical Information" bulletins for engineering changes which have been introduced since publication of this service manual. Technical information bulletins also supplement the parts list until a revised edition is issued.

The special tools mentioned in the descriptions are listed in chapter "Special Servicing Tools" of this manual. Use the part numbers to identify the tools in the "STIHL Special Tools" manual. The manual lists all special servicing tools currently available from STIHL.

Symbols are included in the text and pictures for greater clarity. The meanings are as follows:

In the descriptions:

● = Action to be taken as shown in the illustration (above the text)

– = Action to be taken that is not shown in the illustration (above the text)

In the illustrations:

➔ Pointer (short)

➡ Direction of movement (long)

📖 4.2 = Reference to another chapter, i.e. chapter 4.2 in this example.

Service manuals and all technical Information bulletins are intended exclusively for the use of STIHL servicing dealers. They must not be passed to third parties.

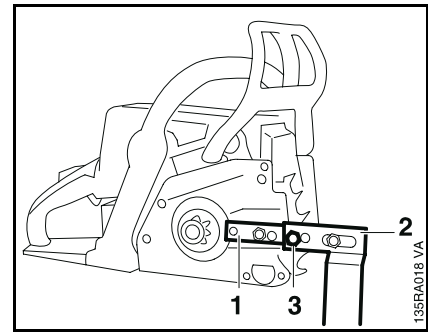

Servicing and repairs are made considerably easier if the clamp (1) 5910 890 2000 is used to mount the machine on assembly stand (2) 5910 890 3100 so that one clamp screw engages the outer 10 mm bore (3) in the assembly stand.

To service the underside of the machine (e.g. remove the oil pump), turn the machine through 180 degrees and mount it so that one clamp screw engages the inner 10 mm bore (1) in the assembly stand.

Note:

Pull the hand guard back against the front handle for this purpose.

Always use original STIHL replacement parts.

They can be identified by the STIHL part number, the **STIHL** logo and the STIHL parts symbol . This symbol may appear alone on small parts.

2. Safety Precautions

If the engine is started up in the course of repairs or maintenance work, observe all local and country-specific safety regulations as well as the safety precautions and warnings in the owner's manual.

Gasoline is an extremely flammable fuel and can be explosive in certain conditions.

Improper handling may result in burns or other serious injuries.

Warning!

Do not smoke or bring any fire, flame or other source of heat near the fuel. All work with fuel must be performed outdoors only. Spilled fuel must be wiped away immediately.

3. Specifications

3.1 Engine

	MS 210	MS 230	MS 250
Displacement:	35.2 cm ³	40.2 cm ³	45.4 cm ³
Bore:	40 mm	40 mm	42.5 mm
Stroke:	28 mm	32 mm	32 mm
Engine power to ISO 7293:	1.6 kW (2.2 HP) at 9,000 rpm	2.0 kW (2.7 HP) at 10,000 rpm	2.3 kW (3.1 HP) at 10,000 rpm
Max. permissible engine speed (with bar and chain):	12,500 rpm	14,000 rpm	14,000 rpm
Idle speed:	2,800 rpm		
Clutch:	Centrifugal clutch without linings		
Clutch engages at:	4,100 rpm		
Crankcase leakage test at gauge pressure:	0.5 bar		
under vacuum:	0.5 bar		

3.1.1 Engine (USA only)

	MS 210	MS 230	MS 250
Displacement:	2.15 cu. in	2.45 cu. in	2.77 cu. in
Bore:	1.57 in	1.57 in	1.67 in
Stroke:	1.10 in	1.26 in	1.26 in
Engine power to ISO 7293:	1.5 kW (2.01 HP)	1.9 kW (2.55 HP)	2.2 kW (2.95 HP)
Max. permissible engine speed (with bar and chain):	12,500 rpm	14,000 rpm	14,000 rpm
Idle speed:	2,800 rpm		
Clutch:	Centrifugal clutch without linings		
Clutch engages at:	4,100 rpm		
Crankcase leakage test at gauge pressure:	7.25 psi		
under vacuum:	7.25 psi		

3.2 Fuel System

Carburetor leakage test at gauge pressure:	0.8 bar (11.6 psi)
Function of tank vent at gauge pressure:	0.3 bar (4.35 psi)
	0.05 bar (0.72 psi)
Fuel:	see owner's manual

3.3 Ignition System

Air gap between ignition module and fanwheel:	0.2 – 0.4 mm (0.008 – 0.015 in)
Spark plug (resistor type):	Bosch WSR 6F NGK BPMR 7A
Electrode gap:	0.5 mm (0.02 in)

3.4 Chain Lubrication

Fully automatic speed-controlled oil pump with rotary piston

Oil delivery rate:	approx. 7.5 cc/min (0.46 cu in/min) at 10,000 rpm
--------------------	---

3.5 Tightening Torques

DG screws are used in the polymer and light-alloy components. These screws form a permanent thread when they are installed for the first time. They can be removed and installed as often as necessary without detrimentally affecting the strength of the screwed assembly, providing the specified tightening torque is observed. For this reason **always use a torque wrench**.

Fastener	Thread size	For component	Torque		Remarks
			kpm	Nm	
Spline screw	IS-M4x15	Cain brake cover	0.2	2.0	
Spline screw	IS-D4x15	Handle molding	0.16	1.6	
Spline screw	IS-P5x16	Connector (engine housing/oil pump)	0.4	4.0	
Spline screw	IS-M4x15	Ground wire (to cylinder)	0.35	3.5	
Spline screw	IS-DG5x24	Handle housing/front handle	0.35	3.5	
Spline screw	IS-DG5x24	Hand guard	0.35	3.5	
Spline screw	IS-DG5x24	Fan housing	0.35	3.5	
Spline screw	IS-DG5x24	Buffer (to front handle)	0.35	3.5	
Spline screw	IS-DG5x24	Buffer (to engine housing)	0.35	3.5	
Spline screw	IS-DG5x24	Ignition module (to engine housing)	0.4	4	
Spline screw	IS-DG5x24	Cylinder (to engine housing)	0.95	9.5	
Collar screw	DG 8x18	Guide bar mounting	1.6	16	
	M12x1	Carrier (clutch)	5.0	50	
	M14x1.25	Spark plug	2.5	25	
Collar locknut	M5	Muffler	0.8	8	
Collar locknut	M5	Filter housing/carburetor	0.27	2.7	
Collar nut	M8x1	Flywheel to crankshaft	2.8	28	
	M12x1.5	Decompression valve	1.4	14	
Spline screw	IS-DG5x16	Spiked bumper	0.37	3.7	

Use the following procedure to fit a DG screw in an existing thread:

- Place the DG screw in the hole and rotate it counterclockwise until drops down slightly.
- Tighten the screw clockwise to the specified torque.

This procedure ensures that the screw engages properly in the existing thread and does not form a new thread, which would weaken the assembly.

Note:

Power screwdriver speed setting for polymer:

- DG screws max. 500 rpm

4. Troubleshooting Chart
4.1 Clutch, Chain Drive, Chain Brake, Chain Tensioner

Condition	Cause	Remedy
Saw chain stops under load at full throttle	Clutch shoes badly worn	Install new clutch
	Clutch drum badly worn	Install new clutch drum
	Brake band stuck	Check freedom of movement and function of brake band
Saw chain rotates at idle speed	Engine idle speed too high	Readjust with idle speed screw (counterclockwise)
	Clutch springs stretched or fatigued	Replace the clutch springs
	Clutch spring hooks broken	Replace the clutch springs
Loud noises	Clutch springs stretched or fatigued	Replace all clutch springs
	Needle cage damaged	Fit new needle cage
	Clutch shoe retainer broken	Fit new retainer
	Clutch shoes and carrier worn	Install new clutch
Chain sprocket wears rapidly	Chain not properly tensioned	Tension chain as specified
	Wrong chain pitch	Fit chain of correct pitch
Saw chain does not stop immediately when brake is activated	Brake spring stretched or broken	Fit new brake spring
	Brake band stretched / worn / broken	Fit new brake band

4.2 Rewind Starter

Condition	Cause	Remedy
Starter rope broken	Rope pulled out too vigorously as far as stop or over edge, i.e. not vertically	Fit new starter rope
	Normal wear	Fit new starter rope
Rewind spring broken (rope does not rewind)	Spring overtensioned – no reserve when rope is fully extended	Fit new rewind spring
	Very dirty or corroded	Clean or replace rewind spring
Starter rope can be pulled out almost without resistance (crankshaft does not turn)	Guide peg on pawl or pawl itself is worn	Fit new pawl
	Spring clip fatigued	Fit new spring clip
Starter rope is difficult to pull and rewinds very slowly	Starter mechanism is very dirty (dusty conditions)	Thoroughly clean complete starter mechanism
	Lubricating oil on rewind spring becomes viscous at very low outside temperatures (spring windings stick together)	Apply a few drops of kerosine (paraffin) to spring, then pull rope carefully several times until normal action is restored

4.3 Chain Lubrication

Important!

In the event of trouble with the chain lubrication system, always investigate the other possible sources of faults before disassembling the oil pump.

Condition	Cause	Remedy
Chain receives no oil	Oil tank empty	Fill up with oil
	Oil inlet hole in guide bar is blocked	Clean oil inlet hole
	Intake hose or pickup body (strainer) clogged or intake hose ruptured	Wash intake hose and pickup body (strainer) in fresh STIHL cleaner or replace if necessary
	Valve in oil tank blocked	Clean or replace valve
	Oil pump damaged or worn	Install new oil pump
Machine losing chain oil	Oil seal leaking	Replace oil seal
	Bore in pump housing worn	Install new oil pump
Oil pump delivers too little oil	Oil pump worn	Install new oil pump

4.4 Ignition System

Warning!

Exercise extreme caution while carrying out maintenance and repair work on the ignition system. The high voltages which occur can cause serious or fatal accidents!

Condition	Cause	Remedy
Engine runs roughly, misfires, temporary loss of power	Spark plug boot is loose	Press boot firmly onto spark plug and fit new spring if necessary
	Spark plug sooted, smeared with oil	Clean the spark plug or replace if necessary
	Weak spark or no spark	Faulty insulation on ignition lead or short circuit wire. Use ohmmeter to check ignition lead for break. If break is detected or high resistance measured, fit a new ignition lead
	Incorrect air gap between ignition coil and flywheel	Set air gap correctly
	Flywheel cracked or has other damage	Install new flywheel
	Crankcase damaged (cracks)	Install new crankcase
	No ignition spark	Check operation of Master Control lever, ignition module and ignition lead

4.5 Carburetor

Condition	Cause	Remedy
Carburetor floods; engine stalls	Inlet needle not sealing. Foreign matter in valve seat or cone damaged	Remove and clean or replace the inlet needle, clean the fuel tank, pickup body and fuel line if necessary
	Inlet control lever sticking on spindle	Free off inlet control lever
	Helical spring not located on nipple of inlet control lever	Remove the inlet control lever and refit it correctly
	Perforated disc on diaphragm is deformed and presses constantly against the inlet control lever	Fit a new metering diaphragm
	Inlet control lever too high (relative to design position)	Set inlet control lever flush with top edge of housing or bottom of metering chamber
Poor acceleration	Idle jet too lean	Back off low speed screw (L) slightly
	Main jet too lean	Back off high speed screw (H) slightly
	Inlet control lever too low (relative to design position)	Set inlet control lever flush with top edge of housing or metering chamber face
	Inlet needle sticking to valve seat	Remove inlet needle, clean and refit
	Connecting bore to atmosphere blocked	Clean bore
	Diaphragm gasket leaking	Fit a new diaphragm gasket
	Metering diaphragm damaged or shrunk	Fit a new metering diaphragm

Condition	Cause	Remedy
Engine will not idle, idle speed too high	Throttle shutter opened too wide by idle speed screw (LA)	Reset idle speed screw (LA) correctly
	Engine leaking	Seal the engine
Engine stalls at idle speed	Idle jet bores or ports blocked	Clean jet bores and ports with compressed air
	Idle jet too rich	Screw down low speed screw (L) slightly
	Setting of idle speed (LA) incorrect – throttle shutter completely closed	Set idle speed screw (LA) correctly
	Small plastic plate in valve jet does not close	Clean or renew valve jet
Engine speed drops quickly under load – low power	Air filter plugged	Clean or renew the air filter
	Tank vent faulty	Clean tank vent or replace if necessary
	Leak in fuel line between tank and fuel pump	Seal connections or install new fuel line
	Pump diaphragm damaged or fatigued	Fit a new pump diaphragm
	Main jet bores or ports blocked	Clean the bores and ports
	Fuel pickup body dirty	Clean the pickup body, fit a new filter
	Fuel strainers dirty	Clean the fuel strainers

4.6 Engine

Always check and, if necessary, repair the following parts before looking for faults on the engine:

- Air filter
- Fuel system
- Carburetor
- Ignition system

Condition	Cause	Remedy
Engine does not start easily, stalls at idle speed, but operates normally at full throttle	Oil seals in crankcase damaged	Replace the oil seals
	Gasket on carburetor spacer flange leaking	Fit a new gasket
	Engine pan leaking	Seal the engine pan
	Crankcase damaged (cracks)	Replace the crankcase
	Muffler leaking	Seal or replace the muffler
Engine does not deliver full power or runs erratically	Secondary air seepage through leaking gaskets on carburetor spacer flange	Fit new gaskets
	Piston rings worn or broken	Fit new piston rings
	Muffler / spark arresting screen carbonized	Clean the muffler (inlet and exhaust), replace spark arresting screen
	Air filter element dirty	Replace air filter element
	Fuel / impulse line severely kinked or damaged	Replace lines or position them free from kinks
	Decompression valve sticking	Replace the decompression valve
Engine overheating	Insufficient cylinder cooling. Air inlets in fan housing blocked or cooling fins on cylinder very dirty	Thoroughly clean all cooling air openings and the cylinder fins

5. Clutch, Chain Drive, Chain Brake and Chain Tensioner

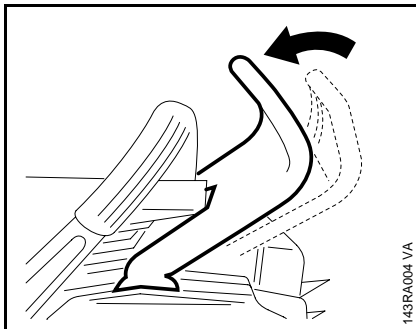

- Remove the chain sprocket cover.
- Disengage the chain brake by pulling the hand guard toward the front handle.

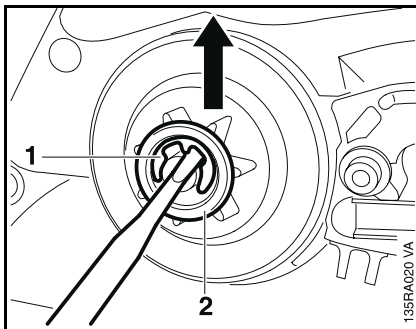

- Remove the E-clip (1).
- Remove the washer (2).

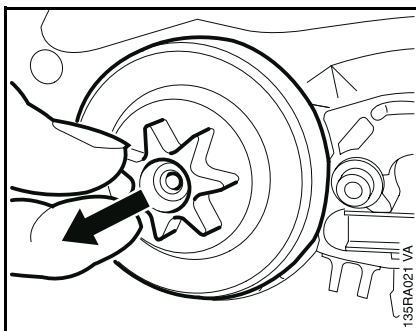

- Remove the rim sprocket, if fitted.
- Pull off the clutch drum / chain sprocket.

5.1 Clutch Drum / Chain Sprocket

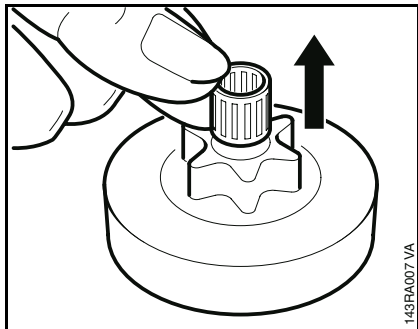

- Take the needle cage out of the sprocket.
- Clean and inspect the clutch drum / chain sprocket.

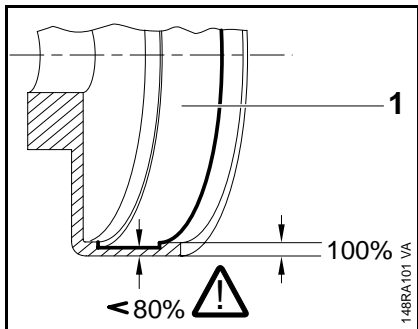

- Inspect the clutch drum (1) for signs of wear.

If there are noticeable wear marks on the inside diameter of the clutch drum, check its wall thickness. If it is less than 80% of the original wall thickness, fit a new clutch drum.

If the clutch drum has to be replaced, also check the brake band –  5.4.

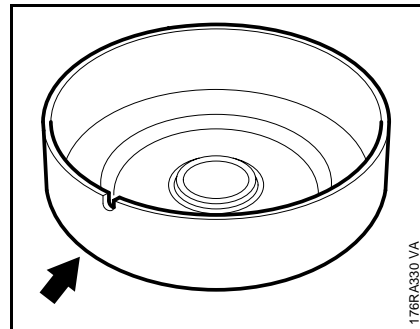

- If the clutch drum/chain sprocket is still serviceable, use No. 120 emery paper or emery cloth (grain size approx. 120 µm) to clean and roughen its friction surface.

Reassemble in the reverse sequence.

- Clean stub of crankshaft. Wash needle cage in clean white spirit and lubricate with grease –  13.
- Replace damaged needle cage.
- Rotate clutch drum/chain sprocket and apply slight pressure at the same time until oil pump drive spring engages properly.
- If rim sprocket was fitted, re-install it with the cavities facing outward.

5.2 Chain Catcher

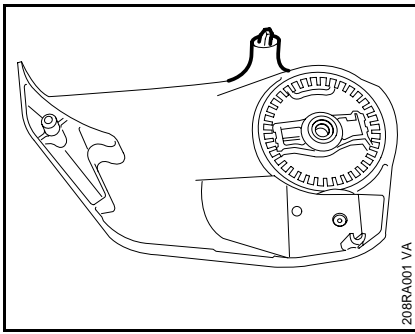

- Sprocket cover with integrally molded chain catcher.

If the chain catcher has broken off, repair as follows:

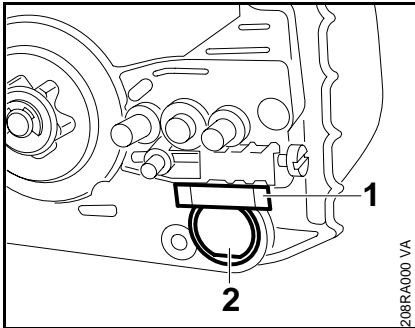

- Remove the chain bumper strip (1).
- Pry the plug (2) out of the front right-hand AV element.

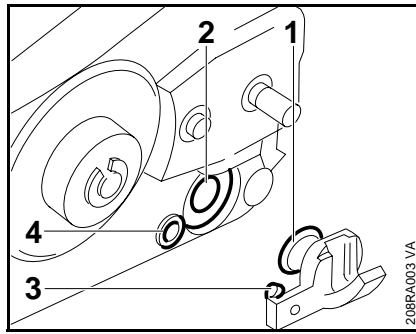

- Oil the cylindrical part (1) of the replacement chain catcher.
 - Push the chain catcher into the AV element (2) and engage the peg (3) in the housing bore (4) at the same time.
- Fit the chain bumper strip.

Assemble all other parts in the reverse sequence.

5.3 Clutch

Troubleshooting chart – 4.1.

- Remove the clutch drum/chain sprocket – 5.1.
- Remove the air filter – 11.1.

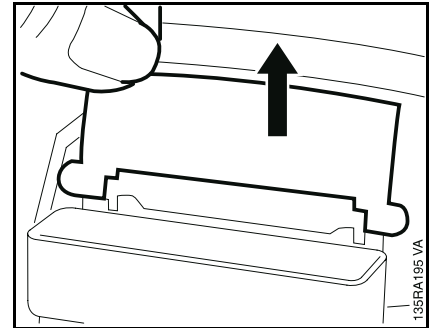

- Take out the shutter.
- Pull boot off the spark plug.
- Unscrew the spark plug.

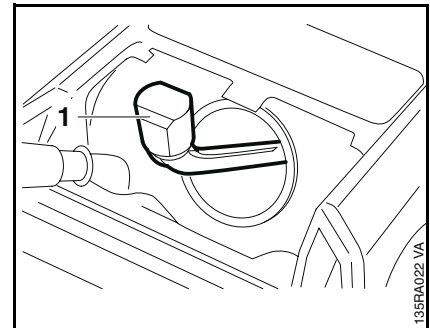

- Close the decompression valve, if fitted.
- Push the locking strip (1) 0000 893 5903 into the cylinder.

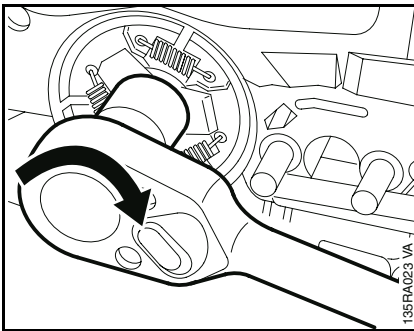

- Unscrew the clutch from the crankshaft clockwise (left-hand thread).

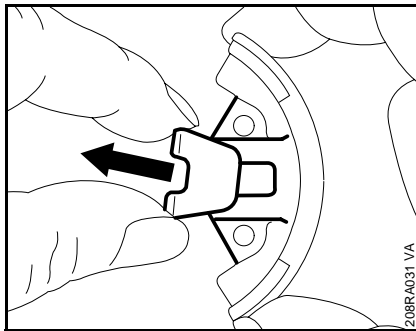

- Pull the retainers, if fitted, off the clutch shoes.

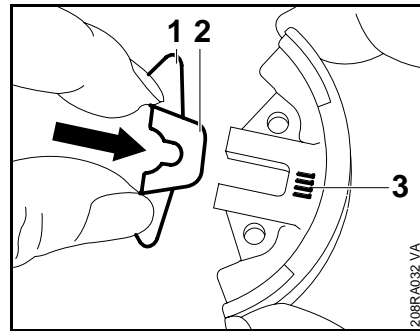

- On retainers with tabs (1), the narrow side (2) must be next to the series number (3).

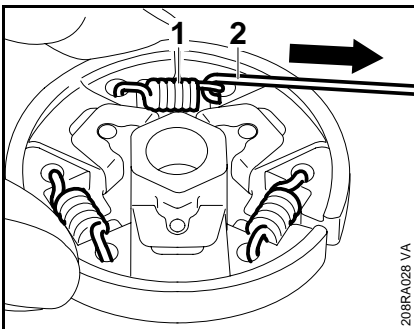

Disassembling the clutch:

- Use hook (2) 5910 890 2800 to remove the clutch springs (1).
- Pull the clutch shoes off the carrier.

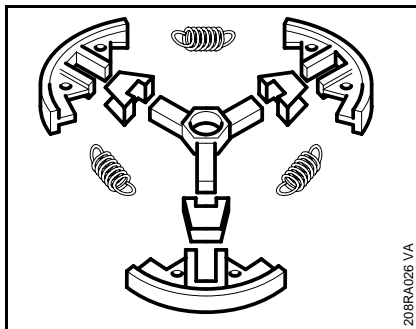

- Clean all parts with STIHL cleaner.
- Replace any damaged parts.

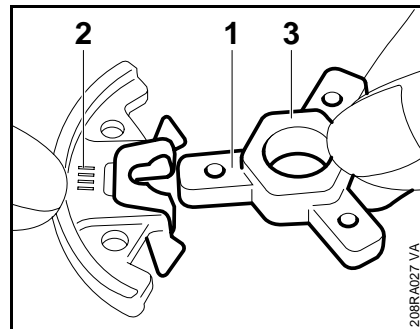

- Fit the clutch shoes over the arms (1) of the clutch carrier so that the series number (2) is on the same side as the larger hexagon (3).

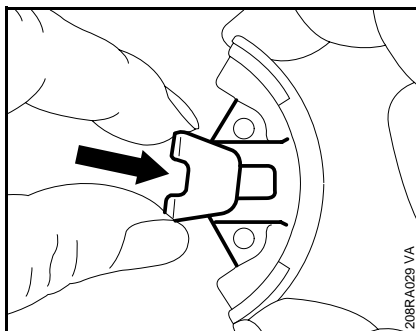

Assembling the clutch:

- Slip the retainers onto the clutch shoes.

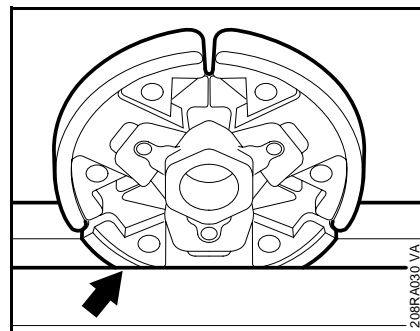

- Clamp the clutch in a vise.

5.4 Chain Brake

5.4.1 Checking Operation

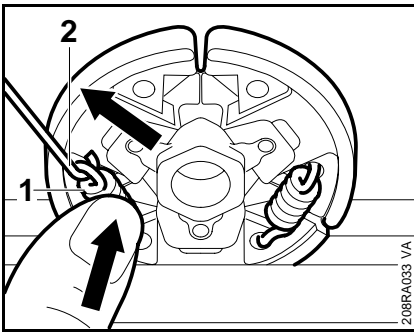

- Attach one end of each spring (1) to the clutch shoes.
- Use the hook (2) 5910 890 2800 to attach other ends of springs and press them firmly into the clutch shoes.

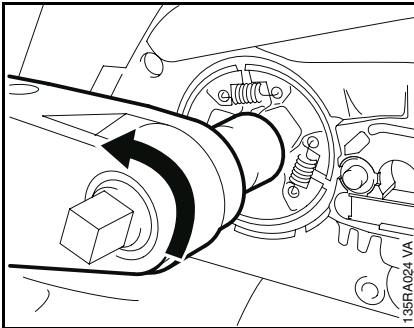

- Screw on the clutch and tighten down to 50 Nm (37 lbf.ft).
- Install the clutch drum / chain sprocket –  5.1.

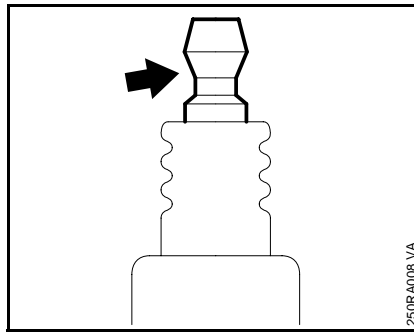

- Remove locking strip from the cylinder.
- Insert spark plug and tighten down to 25 Nm (18.5 lb.ft).
- If spark plug has a separate terminal nut, make sure it is properly tightened down.
- Fit boot on the spark plug.

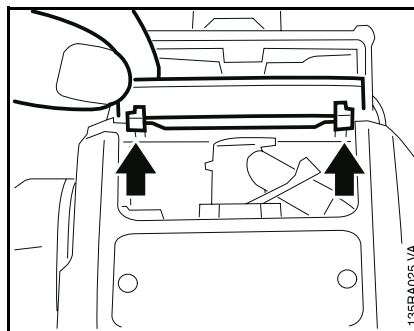

- Fit the shutter so that its lugs engage the recesses in the handle housing.
- Install the air filter –  11.1.

The chain brake is one of the most important safety devices on the chainsaw. Its efficiency is measured in terms of the chain braking time, i.e. the time that elapses between activating the brake and the saw chain coming to a complete standstill. The shorter the braking time, the better the efficiency and protection offered against being injured by the rotating chain.

Contamination (with chain oil, chips, fine particles of abrasion, etc.) and smoothing of the friction surfaces of the brake band and clutch drum impair the coefficient of friction. This, in turn, reduces the frictional forces and thus prolongs the braking time. A fatigued or stretched brake spring has the same negative effect.

- Start the engine.
- With the chain brake activated (locked), open throttle wide for a brief period (max. 3 seconds) – the chain must not rotate.
- With the chain brake released, open throttle wide and activate the brake manually – the chain must come to an abrupt stop.

The braking time is in order if deceleration of the saw chain is imperceptible to the eye.

5.4.2 Removing

- Remove the clutch drum / chain sprocket –  5.1.
- Release brake spring tension by pushing hand guard forward.
- Remove upper bumper strip from the tensioner.

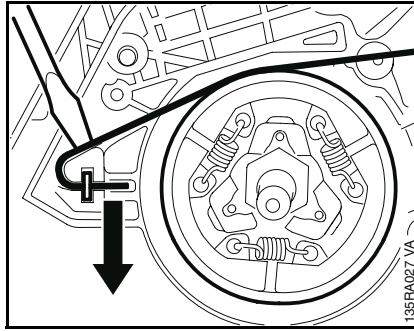

- Pry the brake band out of the engine housing.
- Disconnect the brake band from the bell crank.

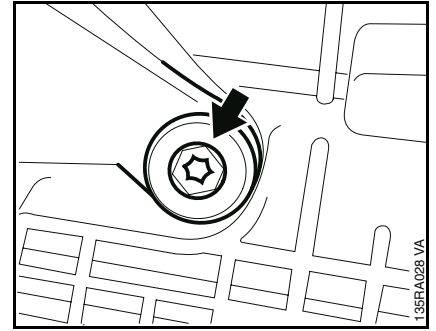

- Remove the screw (arrow) from the hand guard.

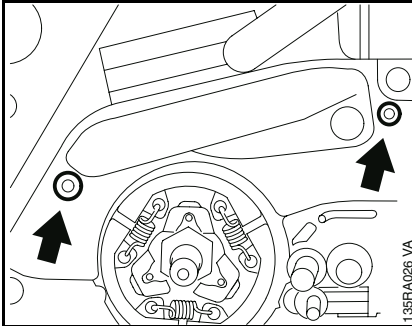

- Take out the screws.
- Remove the cover.

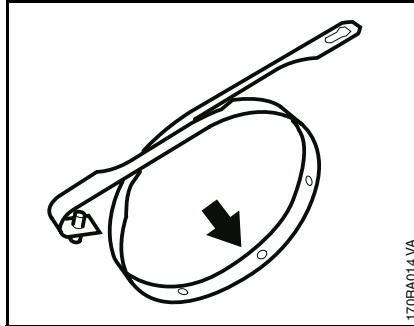

Install a new brake band if:

- there are noticeable signs of wear (large areas on inside diameter and/or parts of outside diameter) and its remaining thickness is less than 0.6 mm (0.024").

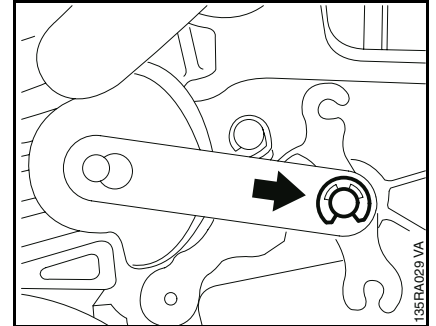

- Remove the E-clip.

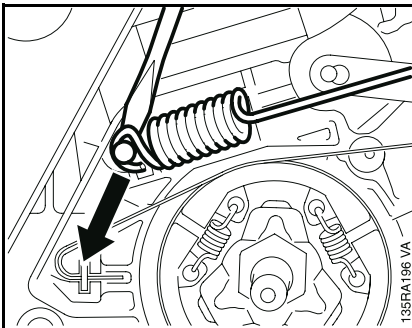

- Carefully ease the brake spring off the anchor pin and take it off the bell crank.

Important!

Thickness of brake band must not be less at any point.

- If the brake band is still serviceable, use No. 120 emery paper or emery cloth (grain size approx. 120 μm) to clean and roughen its entire friction surface (inside diameter).

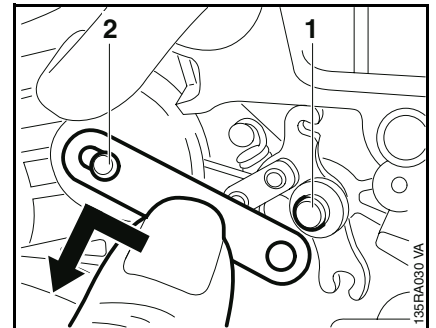

- Remove strap from bell crank pivot pin (1).
- Push the strap sideways and lift it off the hand guard pivot pin (2).

5.4.3 Installing

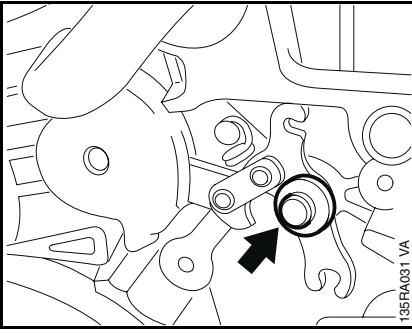

- Remove the washer.

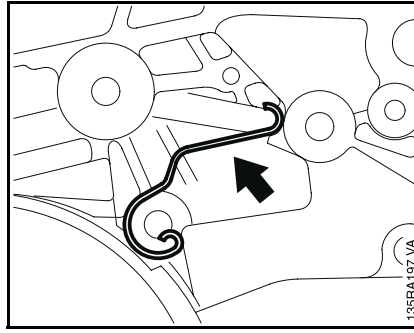

- Remove the flat spring.
- Inspect parts and replace if damaged.
- Clean the entire housing recess for the chain brake.
- If the groove of the brake spring anchor pin is worn, replace the housing.

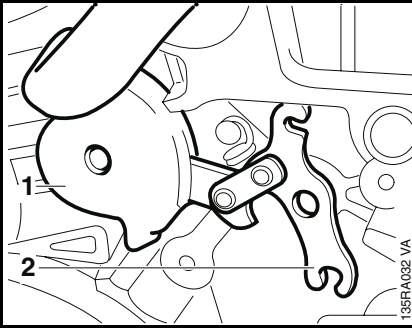

- Carefully pry the hand guard (1) and bell crank (2) off their pivot pins and lift away together.
- Pull the bell crank out of the hand guard.

- Lubricate sliding and bearing points of chain brake with STIHL multipurpose grease or, preferably, molybdenum grease (e.g. Molykote) –  13.
- Install the flat spring.

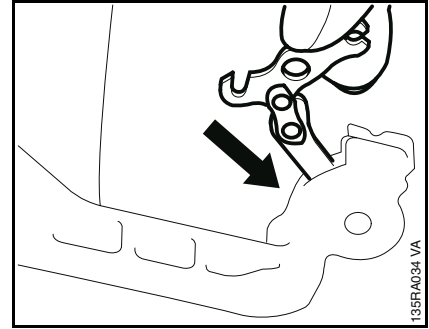

- Insert the bell crank in the side of the hand guard so that the short arm of the bell crank points to top of hand guard.

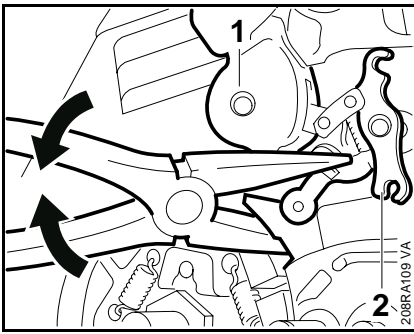

- Position the hand guard (1) against the pivot pin and fit the other side of the hand guard over the housing.
- Position the bell crank (2) against the pivot pin.
- Push the hand guard and bell crank onto their pivot pins.

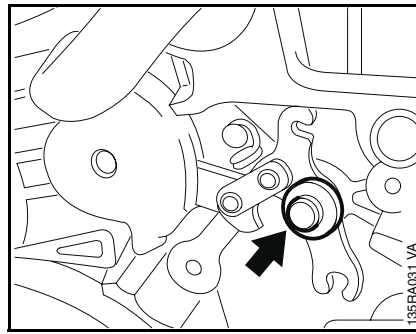

- Fit the washer.

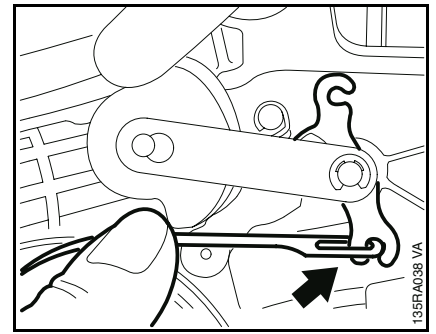

- Hook the brake spring onto the bell crank.

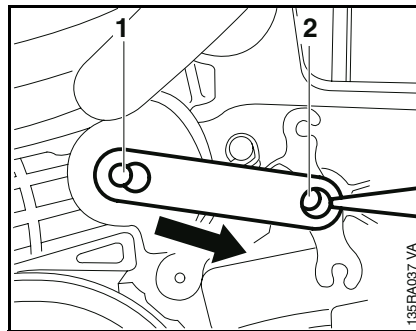

- Fit strap on the pivot pin (1) and engage it in the pivot pin's groove.
- Slip the other end of the strap over the bell crank pivot pin (2).
- Secure strap with E-clip.
- Coat the brake band with chain oil (STIHL Bioplus),  13, to protect it from corrosion and help reduce "snatching" during the first few brake applications.

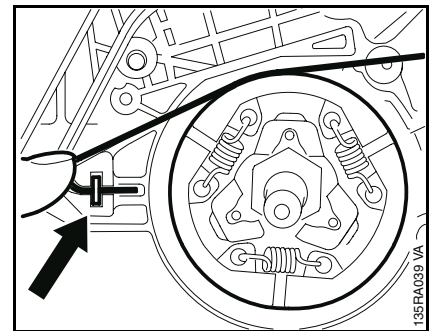

- Position the brake band around the clutch and push it into the engine housing.

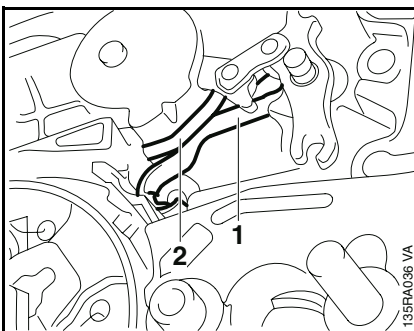

- Check that flat spring (1) is properly located on face (2) of hand guard bearing boss.

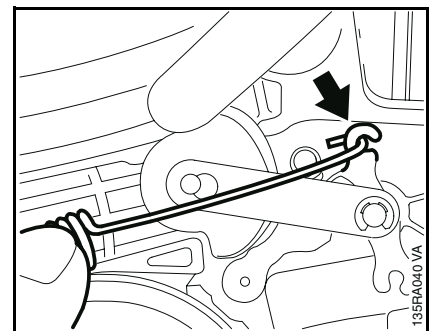

- Attach the brake spring to the bell crank.

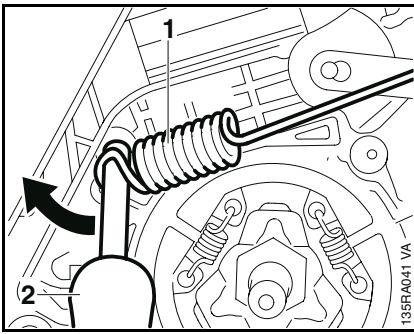

- Use the hook (2) 1117 890 0900 to attach the brake spring (1) to the anchor pin.

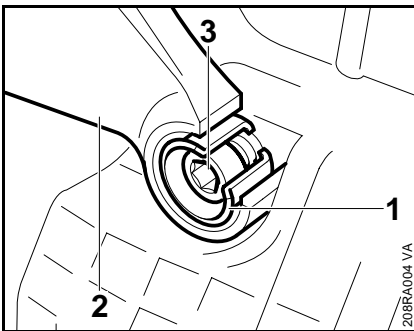

- Fit the bushing (1) in the hand guard (2).
- Insert M5x24 screw (3) and tighten down to 3.5 Nm (2.6 lbf.ft).
- Fit the cover.
- Tighten screws to 2.0 Nm (1.5 lbf.ft).
- Fit upper bumper strip on tensioner.
- Install clutch drum/chain sprocket – 5.1.
- Check operation of chain brake – 5.4.1.

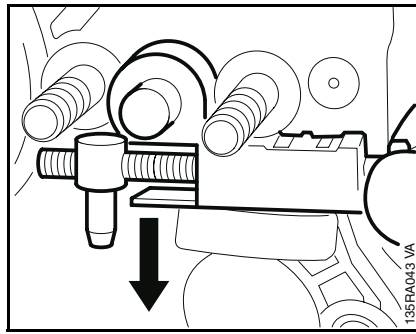

- Remove the chain sprocket cover.
- Pull the cover out of the housing.

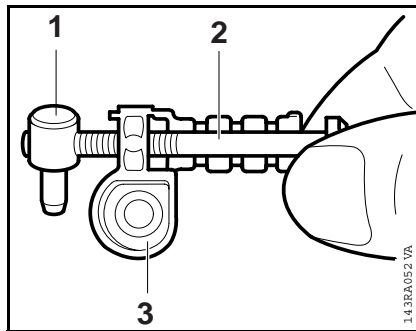

- Unscrew the nut (1) from the adjusting screw (2).
- Take the adjusting screw out of the cover (3).

Reverse the above sequence to install the chain tensioner.

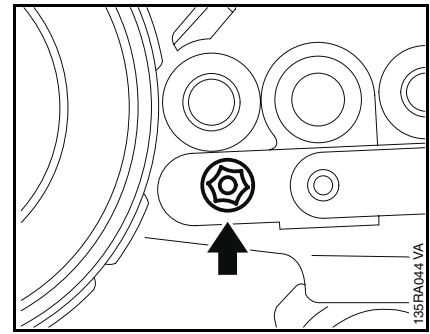

- Remove the chain sprocket cover.
- Take out the screw.
- Pull tensioner assembly out of the engine housing.

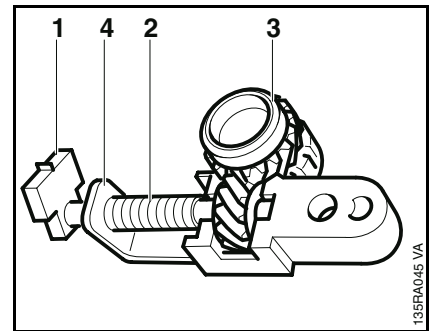

- Take the thrust pad (1) off the adjusting screw (2).
- Rotate the spur gear (3) until the adjusting screw (4) comes out of the tensioner slide (3).

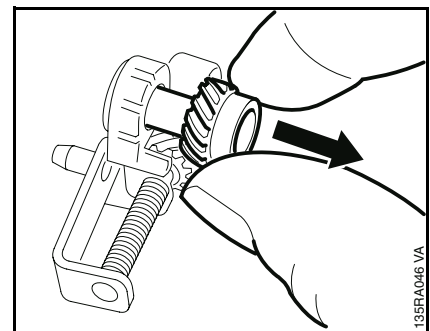

- Pull the spur gear out of the cover.

6. Engine

6.1 Muffler/Spark Arresting Screen

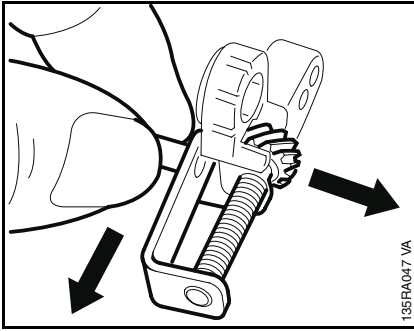

- Pull the tensioner slide off the cover.
- Take the adjusting screw out of the cover.
- Inspect the teeth on the spur gear and adjusting screw. Replace both parts if necessary.

Reverse the above sequence to install the chain tensioner.

- Coat teeth of adjusting screw and spur gear with grease,  13, before refitting.

This machine does not have a conventional crankcase. The engine consists of the cylinder, piston, crankshaft and engine pan.

Troubleshooting chart –  4.6.

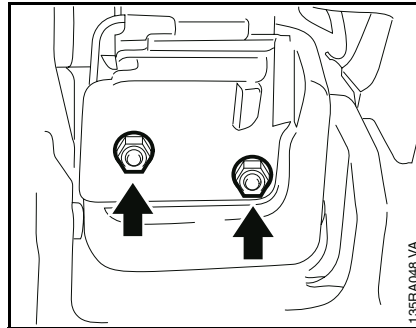

- Unscrew the nuts.
- Remove the muffler.

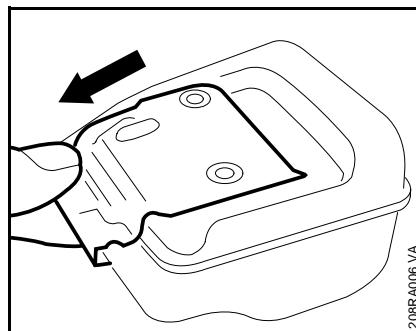

- Pull off or lever off the cover plate – depending on type fitted.
- Remove spark arresting screen, if fitted. Clean the screen or fit a new one if necessary.

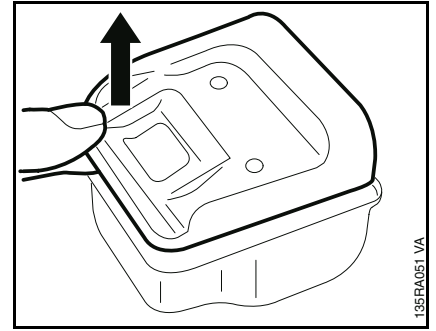

- Muffler with push-fit upper and lower casings: Remove the upper casing from the lower casing.

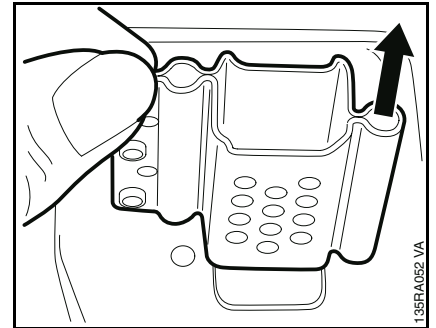

- Muffler with push-fit upper and lower casings: If necessary, take the baffle out of the lower casing.

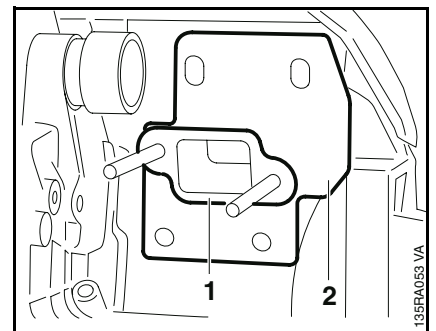

- Remove the gasket (1) and heat shield (2), if fitted.

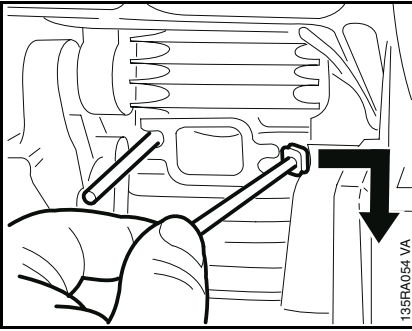

- Remove the screws from the flange.

Reassemble in the reverse sequence.

- Use a new gasket.
- Fit new locknuts and torque down to 8.0 Nm (5.9 lbf.ft).

Defective oil seals and gaskets or cracks in castings are the usual causes of leaks. Such faults allow supplementary air to enter the engine and upset the fuel-air mixture.

This makes adjustment of the prescribed idle speed difficult, if not impossible.

Moreover, the transition from idle speed to part or full throttle is not smooth.

The engine housing can be checked thoroughly for leaks with the carburetor and crankcase tester and the vacuum pump.

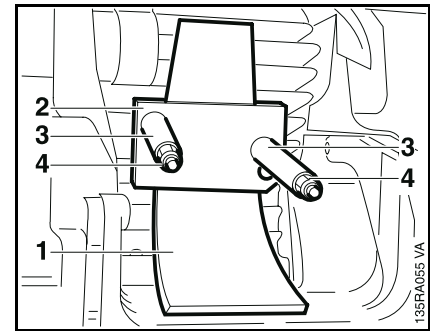

- Remove the muffler –  6.1.

- Fit the sealing plate (1) 0000 855 8106 between the mounting screws.

The sealing plate must completely fill the space between the two mounting screws.

- Slip the flange (2) 1123 855 4200 over the screws.
- Fit the sleeves (3) 1123 851 8300 on the screws.
- Fit the nuts (4) and tighten down securely.

- Remove the carburetor –  11.2.2.

- Set the piston to top dead center (T.D.C.). This can be checked through the inlet port.

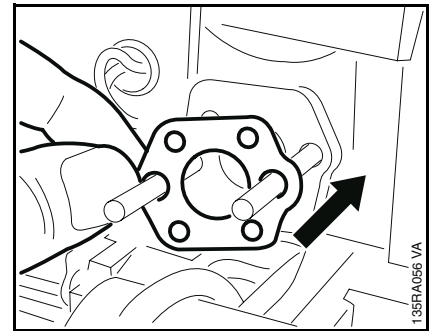

- Inspect carburetor gasket and fit a new one if necessary.

6.2.2 Pressure Test

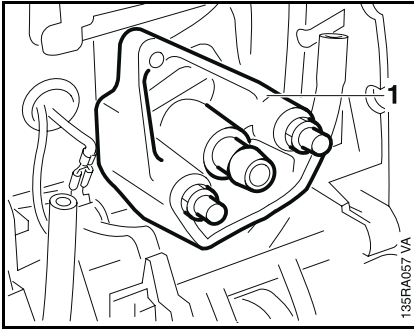

- Fit the test flange (1) 1118 850 4200 in place of the carburetor.

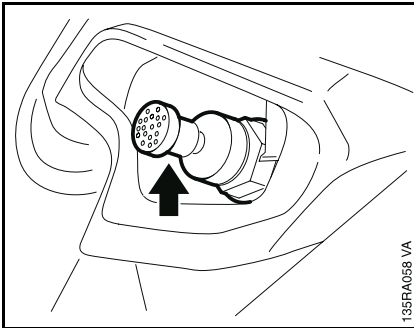

- If decompression valve is fitted, pull out the button.
- Check that spark plug is properly tightened down.
- Perform leakage test with tester 1106 850 2905 and vacuum pump 0000 850 3501.

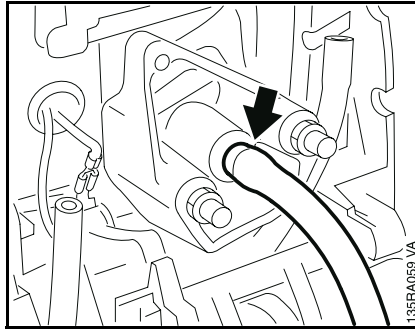

- Carry out preparations – 6.2.1.
- Connect pressure hose of tester 1106 850 2905 to nipple on test flange.

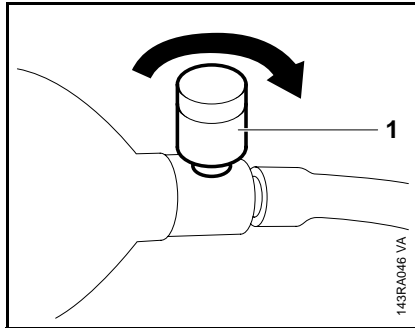

- Close the vent screw (1) on the rubber bulb.
- Pump air into the engine housing with the rubber bulb until the gauge indicates a pressure of 0.5 bar (7.25 psi). If this pressure remains constant for at least 20 seconds, the engine or decompression valve, if fitted, is airtight.

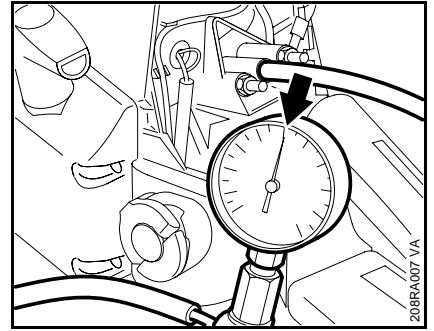

- However, if the indicated pressure drops, the leak must be located and the faulty part replaced.

To find the leak, coat the suspect area with oil and pressurize the engine again. Bubbles will appear if a leak exists.

- If the decompression valve is leaking, fit a new one – 6.9.
- Repeat the pressure test.
- Carry out the vacuum test – 6.2.3.
- After finishing the test, open the vent screw and disconnect the hose.
- Remove the test flange.
- Install the carburetor – 11.2.2.
- Remove the flange.
- Remove the sealing plate.
- Install the muffler – 6.1.

Oil seals tend to fail when subjected to a vacuum, i.e. the sealing lip lifts away from the crankshaft during the piston's induction stroke because there is no internal counterpressure.

An additional test can be carried out with the vacuum pump to detect this kind of fault.

- Carry out the preparations –  6.2.1.

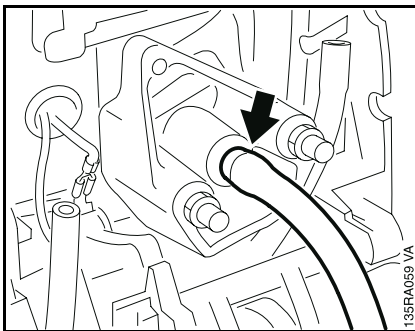

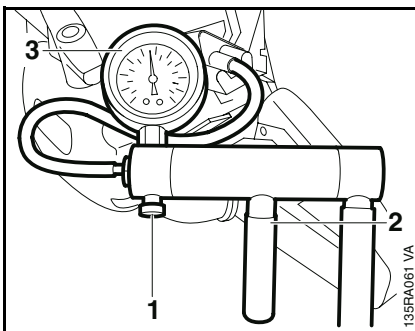

- Connect suction hose of vacuum pump 0000 850 3501 to test flange nipple.



- Close the vent screw (1) on the pump.
- Operate the lever (2) until pressure gauge (3) indicates a vacuum of 0.5 bar (7.25 psi).



If the vacuum reading remains constant, or rises to no more than 0.3 bar (4.25 psi) within 20 seconds, it can be assumed that the oil seals are in good condition.

However, if the pressure continues to rise (reduced vacuum in the engine housing), the oil seals must be replaced.

- After finishing the test, open the vent screw and disconnect the hose.
- Remove the test flange.
- Install the carburetor –  11.2.2.
- Remove the flange.
- Remove the sealing plate.
- Install the muffler –  6.1.

It is not necessary to disassemble the complete engine housing if only the oil seals have to be replaced.

Clutch side:

- Remove the clutch –  5.3.
- Remove the oil pump –  10.5.

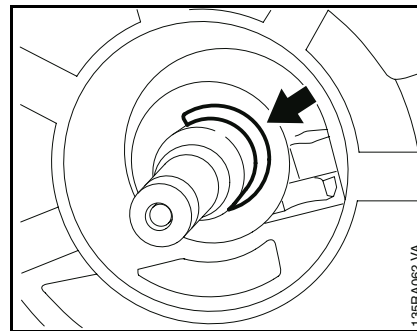

- Ease the retaining ring out of the crankshaft.

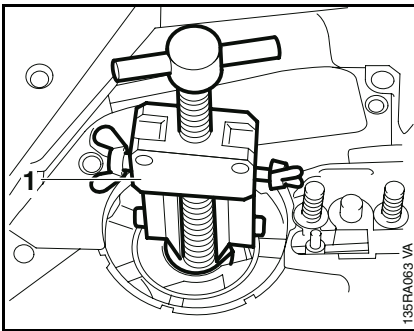

- Apply puller (1) 5910 890 4400 (jaws 0000 893 3711 with No. 6 profile).
- Clamp the puller arms.
- Pull out the oil seal.

Take care not to damage the crankshaft stub.

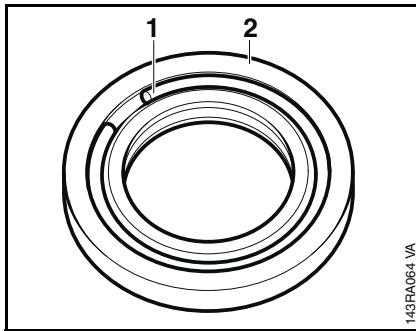

- If an oil seal with clamping ring (1) is installed, use puller and No. 3.1 jaws to remove the clamping ring (2) out of the housing.
- Clean sealing face with STIHL cleaner – 13.

If the cylinder and engine pan are assembled, only oil seal 9638 003 1581 (with clamping ring) may be installed.

- Lubricate sealing lip of oil seal with grease – 13.
- Thinly coat the outside diameter of the oil seal with sealant – 13.

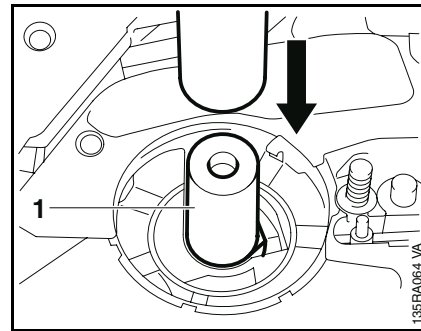

- Place the oil seal in position with the clamping ring faces up.
- Use the press sleeve (1) 1123 893 2400 to install the oil seal.
- Wait about one minute, then rotate the crankshaft.
- Fit a new retaining ring.
- Install the oil pump – 10.5.
- Install the clutch – 5.3.

Ignition side:

- Remove the flywheel – 7.5.

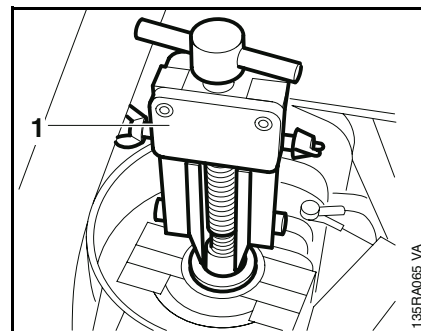



- Apply puller (1) 5910 890 4400 (jaws 0000 893 3711 with No. 6 profile).
- Clamp the puller arms.
- Pull out the oil seal.

Take care not to damage the crankshaft stub.

- Remove oil seal with clamping ring as described for clutch side.
- Cleaning sealing face with STIHL cleaner –  13.

If the cylinder and engine pan are assembled, only oil seal 9638 003 1581 (with clamping ring) may be installed.

- Lubricate sealing lip of oil seal with grease –  13.
- Thinly coat the outside diameter of the oil seal with sealant –  13.

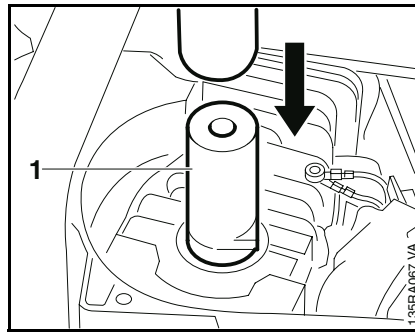

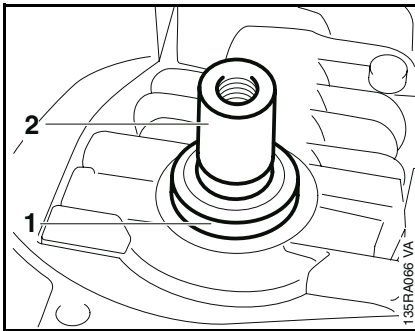

- Use the press sleeve (1) 1123 893 2400 to install the oil seal.
- Wait about one minute, then rotate the crankshaft.
- Install the flywheel –  7.5.



- Place the oil seal (1) in position with the clamping ring facing up.
- Screw the guide sleeve (2) 1123 894 7700 onto the crankshaft.

Always check and, if necessary, repair the fuel system, carburetor, air filter and ignition system before looking for faults on the engine.

- Remove the handle housing –  9.3.
- Remove the oil pump –  10.5.

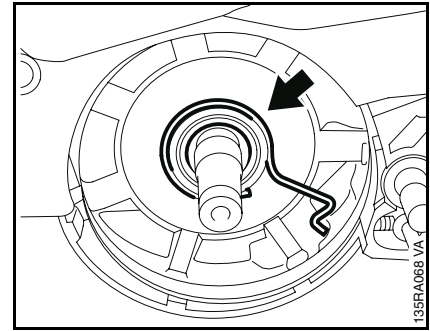

- Pull off the worm with drive spring.

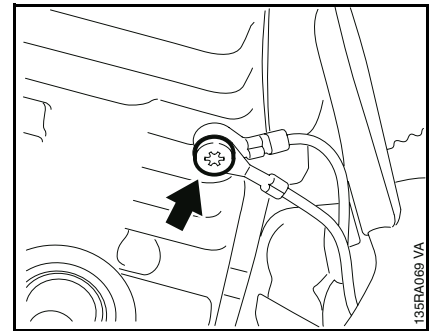

- Take out the ground wire fastening screw.

6.5 Cylinder

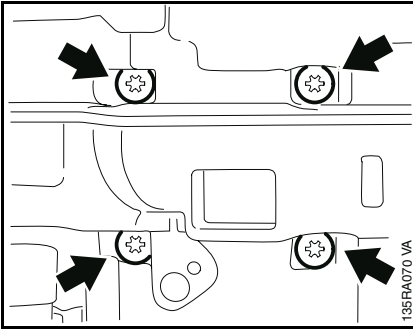

- Unscrew the engine pan mounting screws.

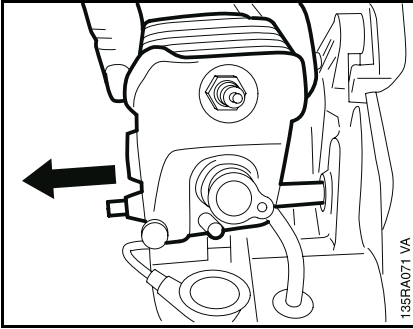

- Remove engine sideways from housing.

Install in the reverse sequence.

- Tighten down the engine pan mounting screws to 9.5 Nm (7 lbf.ft) and the ground wire fastening screw to 3.5 Nm (2.6 lbf.ft).

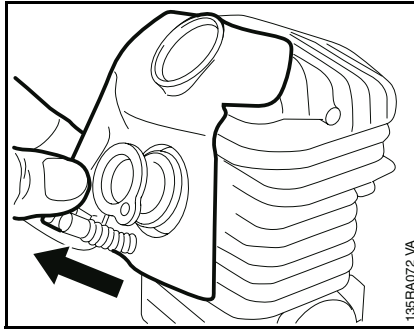

- Remove the engine – 6.4.

- Take out the spark plug.

- Remove baffle plate.

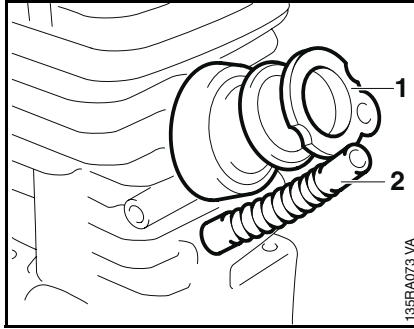

- Pull the manifold (1) off the intake port.

- Disconnect the impulse hose (2).

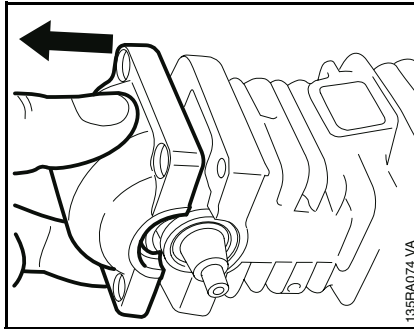

- Pull the engine pan off the cylinder.

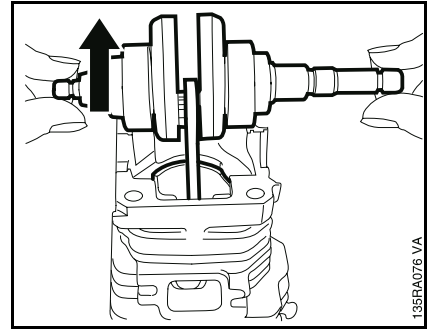

- Lift the crankshaft and pull the piston out of the cylinder at the same time.

- Inspect ball bearings and oil seals and replace if necessary – 6.8.

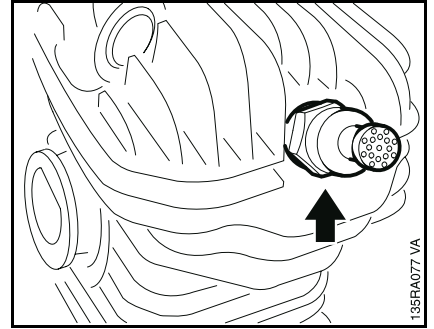

- Inspect the cylinder and replace it if necessary.

- On easy start version, unscrew the decompression valve.

- If a new cylinder has to be installed, always fit the matching piston. Replacement cylinders are only supplied complete with piston for this reason.

- Thoroughly clean all residue of sealant from the cylinder and engine pan mating faces.

- Apply a thin coating of sealant to the outer diameters of the oil seals – 13.

- Lubricate piston and piston ring with oil.

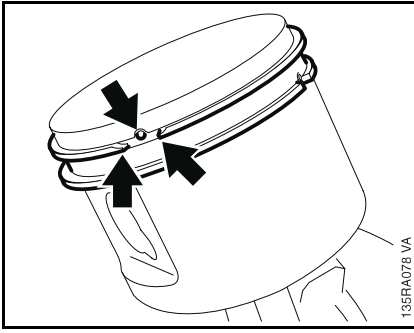

- Position the piston rings so that the radii at the ring gap meet at the fixing pin in the piston groove when the rings are compressed.

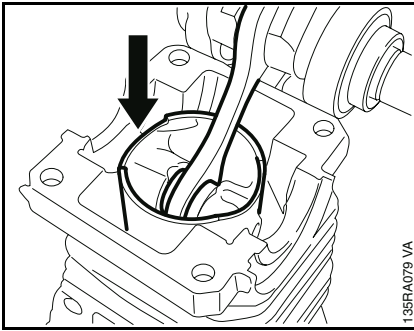

- Slide piston carefully into the cylinder.

The piston rings are compressed by the inner taper of the cylinder.

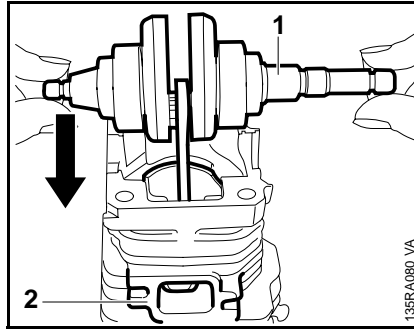

- Position the crankshaft so that the long crankshaft stub (1) points to the right, looking at exhaust port (2).
- Push piston home until ball bearings are seated.

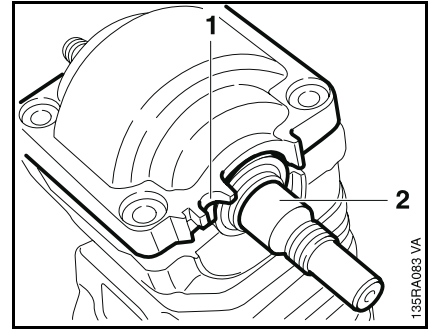

- Fit the engine pan so that the seat (1) for the oil pump is at the same side as the long crankshaft stub (2).

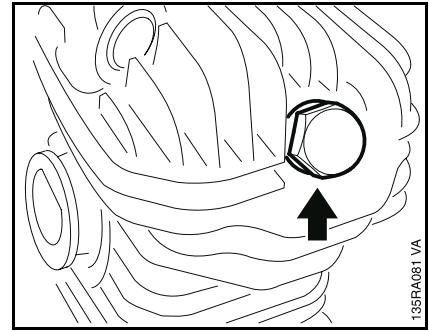

- On easy start version, unscrew the plug, screw home the decompression valve and tighten it to 14 Nm (10.3 lbf.ft).

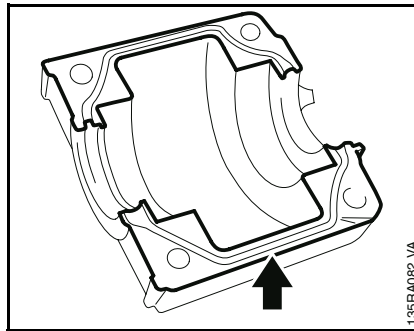

- Apply a thin bead of sealant to the engine pan mating face –  13.

Follow manufacturer's instructions for use of sealant.

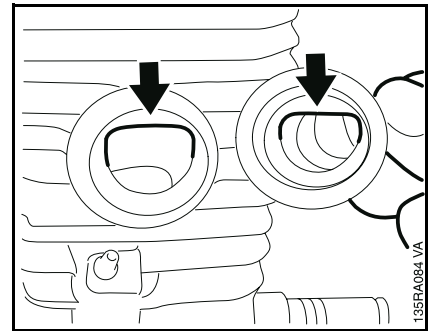

- Push the manifold on to the intake port so that the straight faces are in alignment.

Assemble all other parts in the reverse sequence.

6.6 Piston

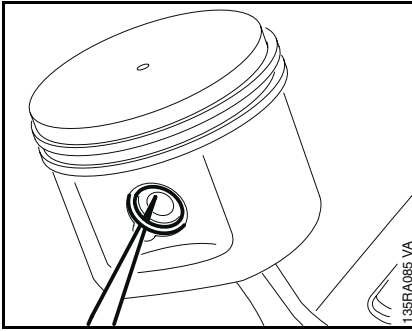

- Pull the piston out of the cylinder – 6.5.
- Ease the hookless snap rings out of the grooves in the piston bosses.

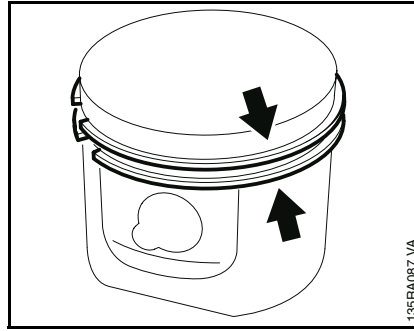

- Inspect piston rings and replace if necessary – 6.7.

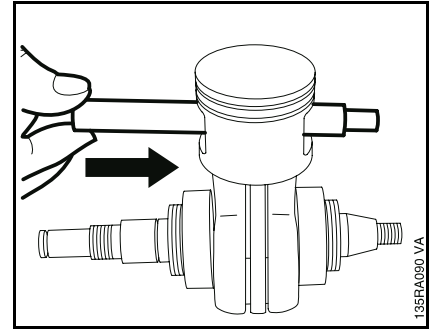

- Push the assembly drift, small diameter first, through the piston and small end (needle cage) and line up the piston.

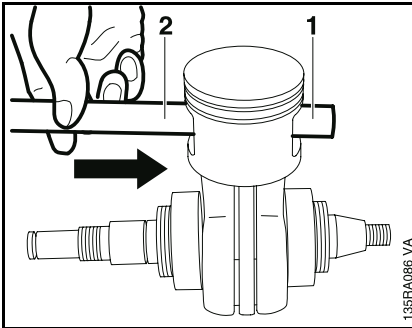

- Use the assembly drift (2) 1110 893 4700 to push the piston pin (1) out of the piston.

If the piston pin is stuck, release it by tapping the end of the drift **lightly** with a hammer. **Hold** the piston steady during this process to **ensure** that no jolts are transmitted to the connecting rod.

- Remove the piston from the connecting rod.
- Inspect needle cage and replace if necessary.

If needle cage is press-fitted, replace the crankshaft.

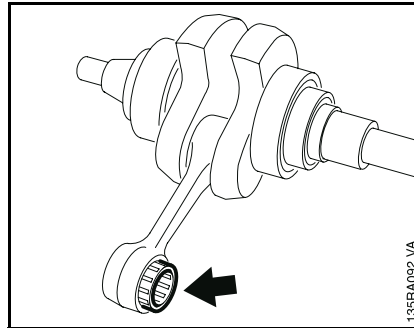

- Fit needle cage (arrow) in the connecting rod (not MS 210).
- Oil the needle cage.

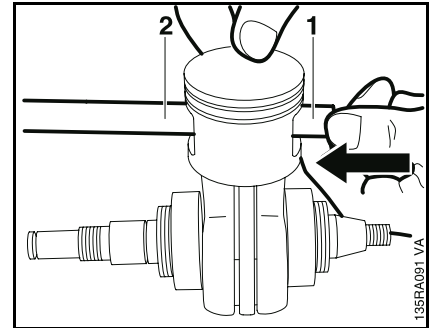

- Fit the piston pin (1) on the assembly drift (2) and slide it into the piston (the pin slides home easily if the piston is warm).

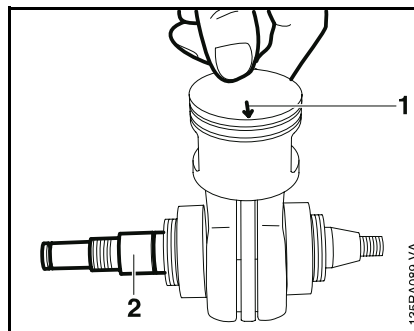

- To ease assembly, heat the piston slightly and push it over the connecting rod.

Installed position of piston:
1 = Arrow
2 = Long stub of crankshaft

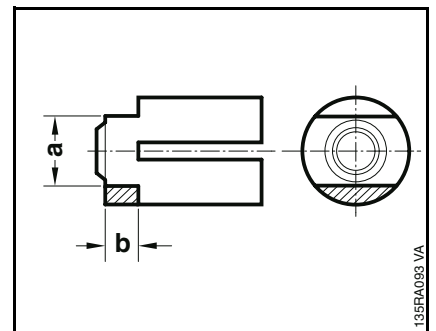

- Modify sleeve of the installing tool 5910 890 2210 as shown:

a = 16 mm (11/16")
b = 8 mm (5/16")

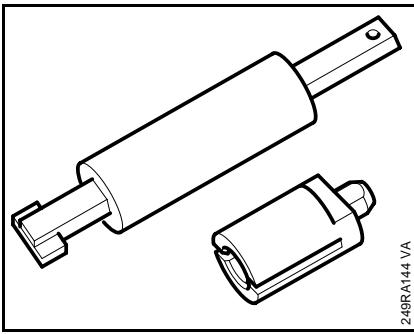

- Remove the sleeve from the tool.

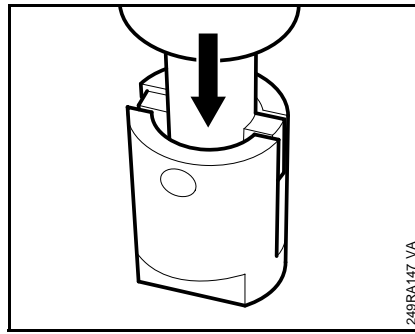

- Stand the installing tool, sleeve downward, on a flat surface (wooden board) and press vertically downwards until the sleeve butts against the tool's shoulder.

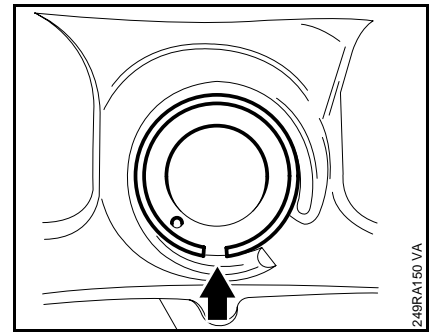

Fit the snap rings so that their gaps are on the piston's vertical axis (they must point either up or down – see arrow).

– Install the piston – 6.5.

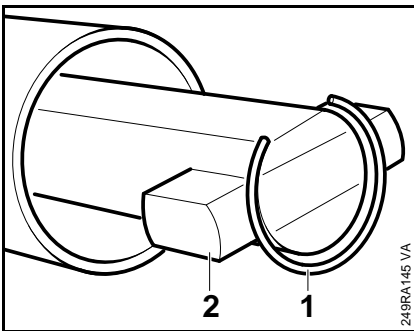

- Attach the snap ring (1) to the magnet (2) so that the snap ring gap is on the flat side of the tool's shank.

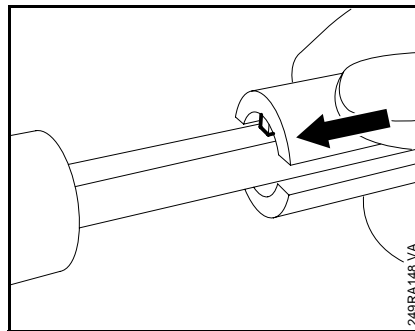

- Remove the sleeve and slip it onto the other end of the shank.

Inner pin must again point toward flat face.

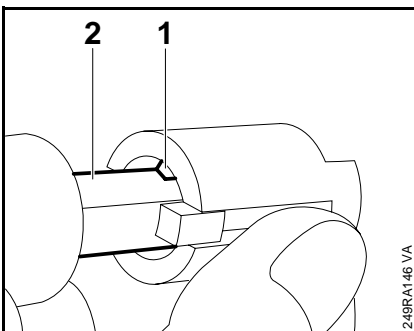

- Push the large slotted diameter of the sleeve over the magnet and snap ring. Position the sleeve so that the inner pin (1) points toward the flat face (2) of tool's shank.

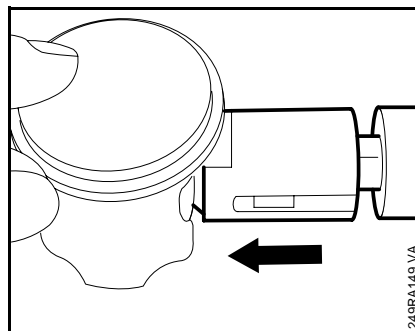

- Apply the installing tool to the piston boss, hold the piston steady, center the tool shank exactly and press home until the snap ring slips into the groove.

6.7 Piston Rings

- Pull the piston out of the cylinder –  6.6.
- Remove rings from the piston.

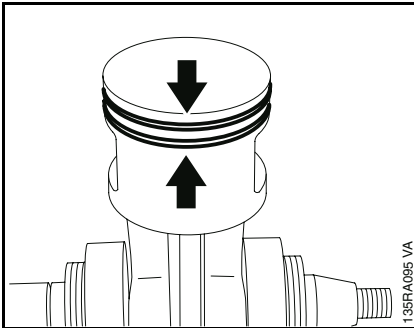

- Use a piece of old piston ring to scrape the grooves clean.

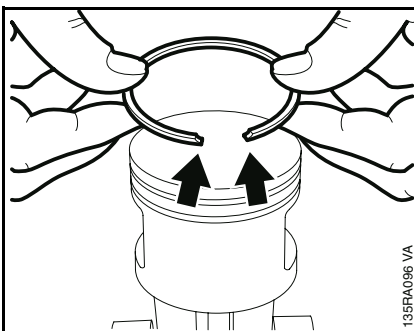

- Install the new piston rings in the grooves so that the radii face upward.
- Install the piston –  6.6.

6.8 Crankshaft

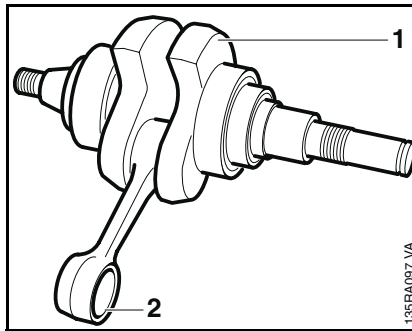

- The crankshaft (1) and connecting rod are an inseparable unit. This means the crankshaft must always be replaced as a complete unit. The needle bearing (2) is replaceable on models MS 230 and MS 250.

When fitting a replacement crankshaft, always install new ball bearings and oil seals.

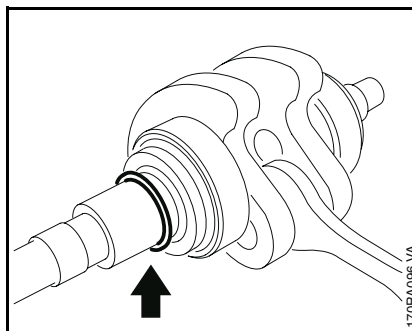

- Remove the piston –  6.6.
- Remove the retaining ring (arrow).

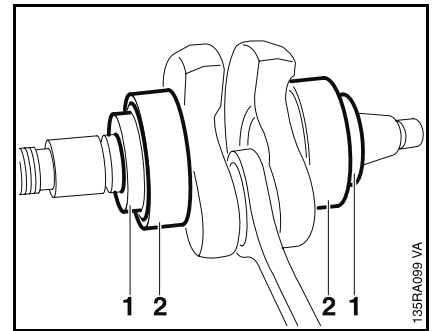

- Pull off the oil seals (1) and ball bearings (2).

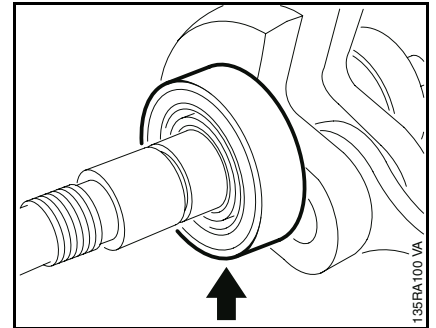

- Heat ball bearing to approx. 50°C (120°F) and, with closed side facing outwards, push it on to the crankshaft stub as far as stop.

If the crankshaft has been removed, the oil seals used in production (9639 003 1585 with rigid housing) may be installed.

- Lubricate sealing lips of oil seals with grease –  13.

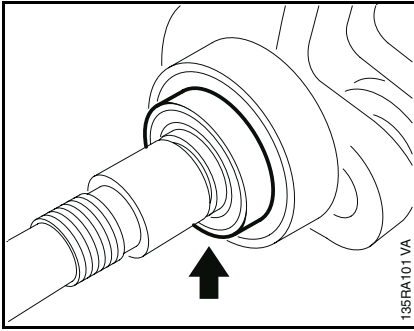

- Slide oil seals over the crankshaft stubs so that their open sides are facing the ball bearings.
- Install new retaining ring in crankshaft groove.
- Install the piston – 6.6.

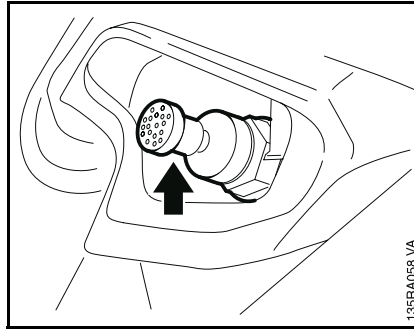

- Remove the front handle – 9.2.
- Use standard 13 mm socket to unscrew the decompression valve.
- Install new decompression valve and torque down to 14 Nm (10.5 lbf.ft).
- Refit the front handle.

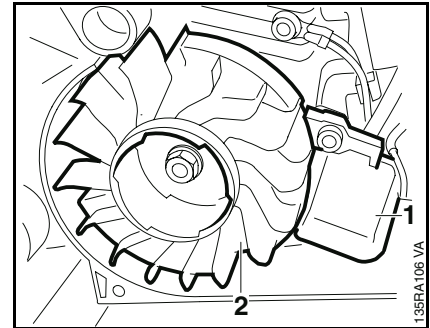

Exercise extreme caution when troubleshooting and carrying out maintenance or repair work on the ignition system. The high voltages which occur can cause serious or even fatal accidents!!

Troubleshooting on the ignition system should always begin at the spark plug – 4.4.



The electronic (breakerless) ignition system basically consists of an ignition module (1) and flywheel (2).

7.1 Spark Plug Boot

- Remove the air filter –  11.1.
- Pull out the shutter –  5.3.
- Pull boot off the spark plug.

The ignition lead is molded to the module.

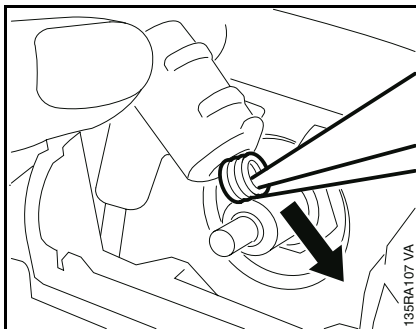

- Use pliers to grip the leg spring and pull it out of the spark plug boot.
- Unhook the leg spring from the ignition lead.
- Pull the spark plug boot off the ignition lead.
- Coat end of the ignition lead (about 20 mm/3/4") with oil.
- Fit spark plug boot over the ignition lead.
- Use pliers to grip the end of the ignition lead inside the spark plug boot and pull it out.

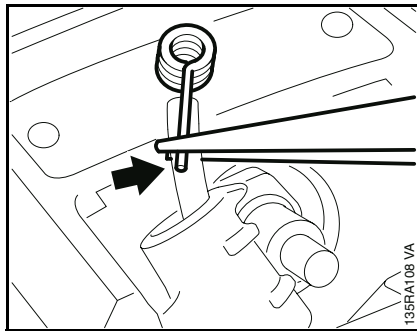

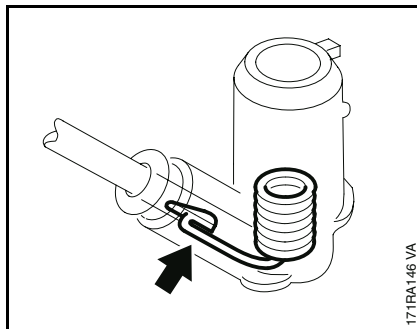

- Pinch the hook (arrow) of the leg spring into the center of the lead, i.e. about 10 mm (3/8") from the end of the lead.



- Pull the lead back into the boot so that the leg spring locates properly inside it (see arrow).

If the spark plug has a separate terminal nut, make sure that it is properly tightened down.

- Fit boot on the spark plug.
- Fit the shutter –  5.3.
- Install the air filter –  11.1.

7.2 Ignition Module

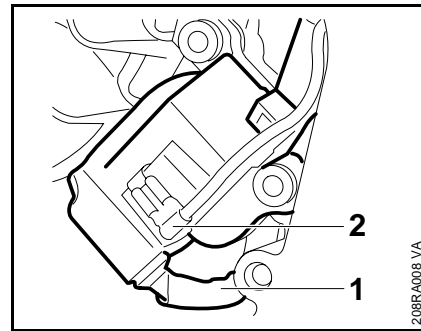

The ignition module accommodates all the components required to control ignition timing. There are two electrical connections on the coil body:

- the high voltage output with ignition lead (1),
- the connector tag (2) for the short circuit wire.

Accurate testing of the ignition module is only possible with a special tester. For this reason it is only necessary to carry out a spark test in the workshop.

A new ignition module must be installed if no ignition spark is obtained (after checking that wiring and stop switch are in good condition).

7.3 Testing the Ignition Coil

To test the ignition module, use either the ZAT 4 ignition system tester 5910 850 4503 or the ZAT 3 ignition system tester 5910 850 4520.

The ignition test refers only to a spark test, not to ignition timing. Before starting the test, check that the spark plug is in good condition. Test the ignition coil only with the spark plug properly installed in the cylinder.

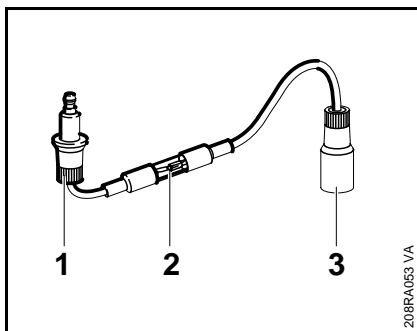

- Using the ZAT 4 ignition tester 5910 850 4503: Pull the boot off the spark plug and connect it to the input terminal (1). Push the tester's output terminal (3) onto the spark plug.
- Pull the rewind starter and check the sparkover in the tester's window (2).

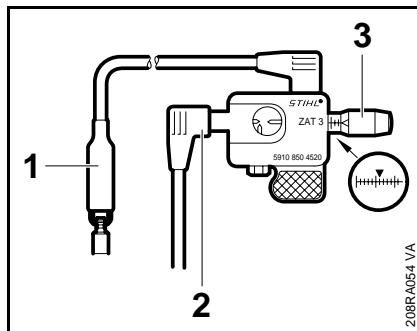

It is necessary to use the ZAT 3 ignition system tester 5910 850 4520 to test the auxiliary spark gap.

- Before starting the test, install a new spark plug in the cylinder and tighten it down firmly – 3.5.
- Pull the boot off the spark plug boot and connect it to terminal (2).
- Attach ground terminal (1) (alligator clip) to spark plug.

Use adjusting knob (3) to set spark gap to about 2 mm.

While using the ZAT 3, hold it only by the handle or position it in a safe place.

Warning!

High voltage – risk of electrocution.

- Crank engine with rewind starter (min. 1,000 rpm) and evaluate spark in spark window.

If a spark is visible, the ignition system is in order.

If no spark is visible, check the wiring harness and contact spring – 7.4.

7.4 Checking the Wiring Harness

If the spark plug, ignition lead and spark plug boot are in order, use an ohmmeter to check the short circuit wire, ground wire and contact spring for a break.

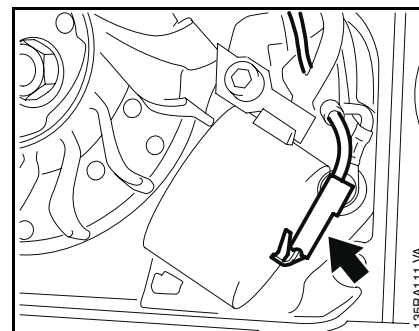



- Pull the short circuit wire (arrow) off the tag on the ignition module.
- Connect ohmmeter to ground and the short circuit wire.
- Set Master Control lever to "0".

The measured resistance must be about 0 Ohm. If the reading is much higher, there is a break in the wire and the wire or Master Control lever must be replaced.

- Set Master Control lever to "1".

The measured resistance must be infinitely high. If not, install a new Master Control lever.

If no fault is found, perform the following additional checks:

- Check flywheel for damage –  7.4.2.
- Check air gap between flywheel and ignition module –  7.5.

If no fault is detected in these areas either, install a new ignition module –  7.4.2.

Ignition timing is not adjustable.

Since there is no mechanical wear in these systems, ignition timing cannot get out of adjustment. However, an internal fault in the circuit can alter the switching point in such a way that a spark test will still show the system to be in order although timing is outside the permissible tolerance. This will impair engine starting and running behavior.

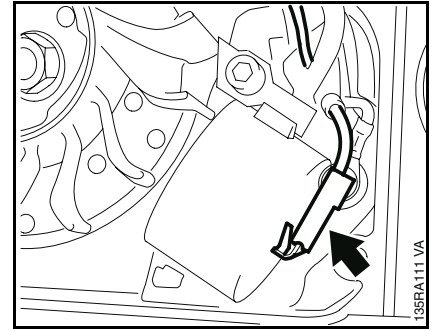

- Remove the fan housing –  8.2.
- Pull the short circuit wire off the tag on the ignition module.

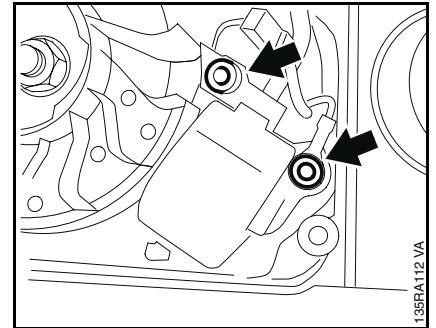

- Take out the screws (arrows).

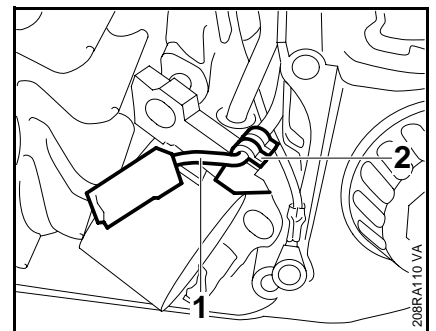

- Pull the ignition module forward a little.
- Take the short circuit wire (1) out of the retainer (2).

7.5 Flywheel

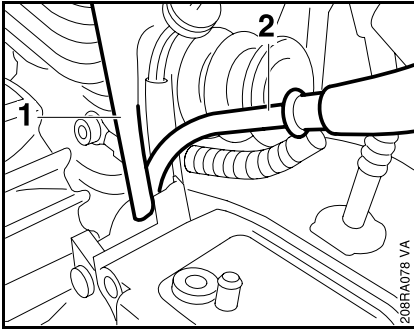

- Push baffle plate (1) in direction of fanwheel and carefully pull out the ignition lead (2).

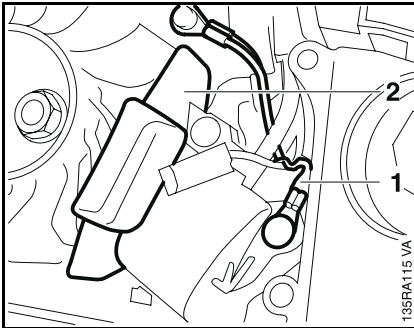

- Place the module in position, insert the screws but do not tighten them down yet.
- Secure ground wire (1) with outer screw.
- Slide the setting gauge (2) 1111 890 6400 between the arms of the ignition module and the flywheel magnet poles.
- Press the ignition module against the setting gauge and tighten down the mounting screws to 4 Nm (3 lbf.ft).

Reassemble all other parts in the reverse sequence.

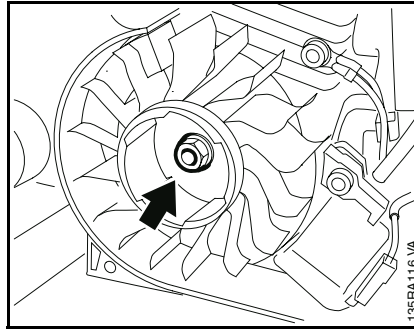

Removing the flywheel:

- Fit the locking strip to block the piston – 5.3.
- Remove the fan housing – 8.2.
- Unscrew the flywheel nut.
- Pull off the flywheel.

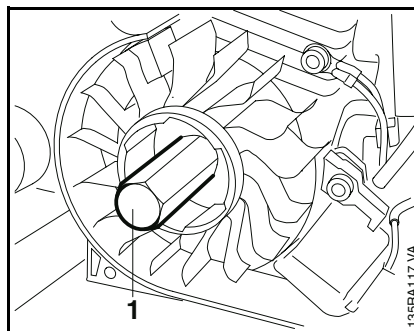

If the flywheel cannot be removed by hand, screw on the puller (1) 1116 893 0800 and tap its end to release the flywheel. Remove the puller.

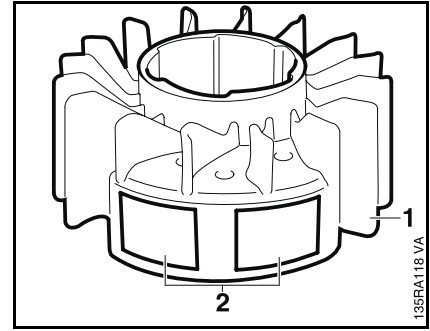

Inspect flywheel (1) and magnet poles (2) for cracks or other damage. If you find any damage, install a new flywheel.

Installing the flywheel:

Degrease crankshaft stub and bore in flywheel with STIHL cleaner – 13.

- Fit the flywheel.

Check position of slot.

Assemble all other parts in the reverse sequence.

- Tighten the flywheel nut to 28 Nm (20.6 lbf.ft).

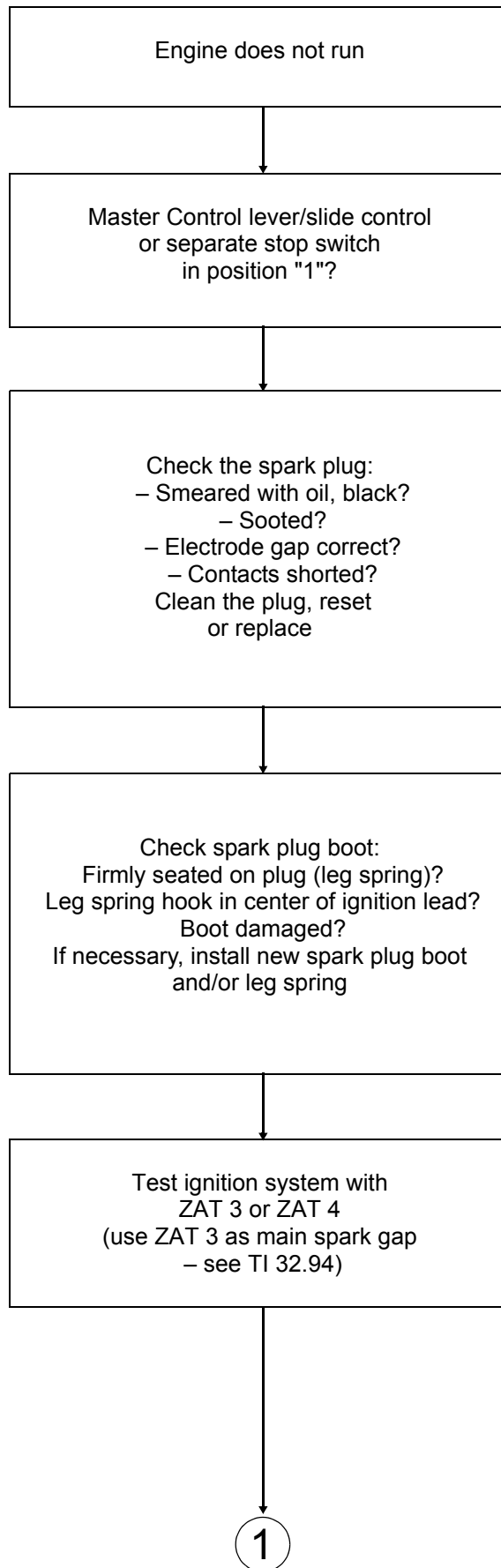

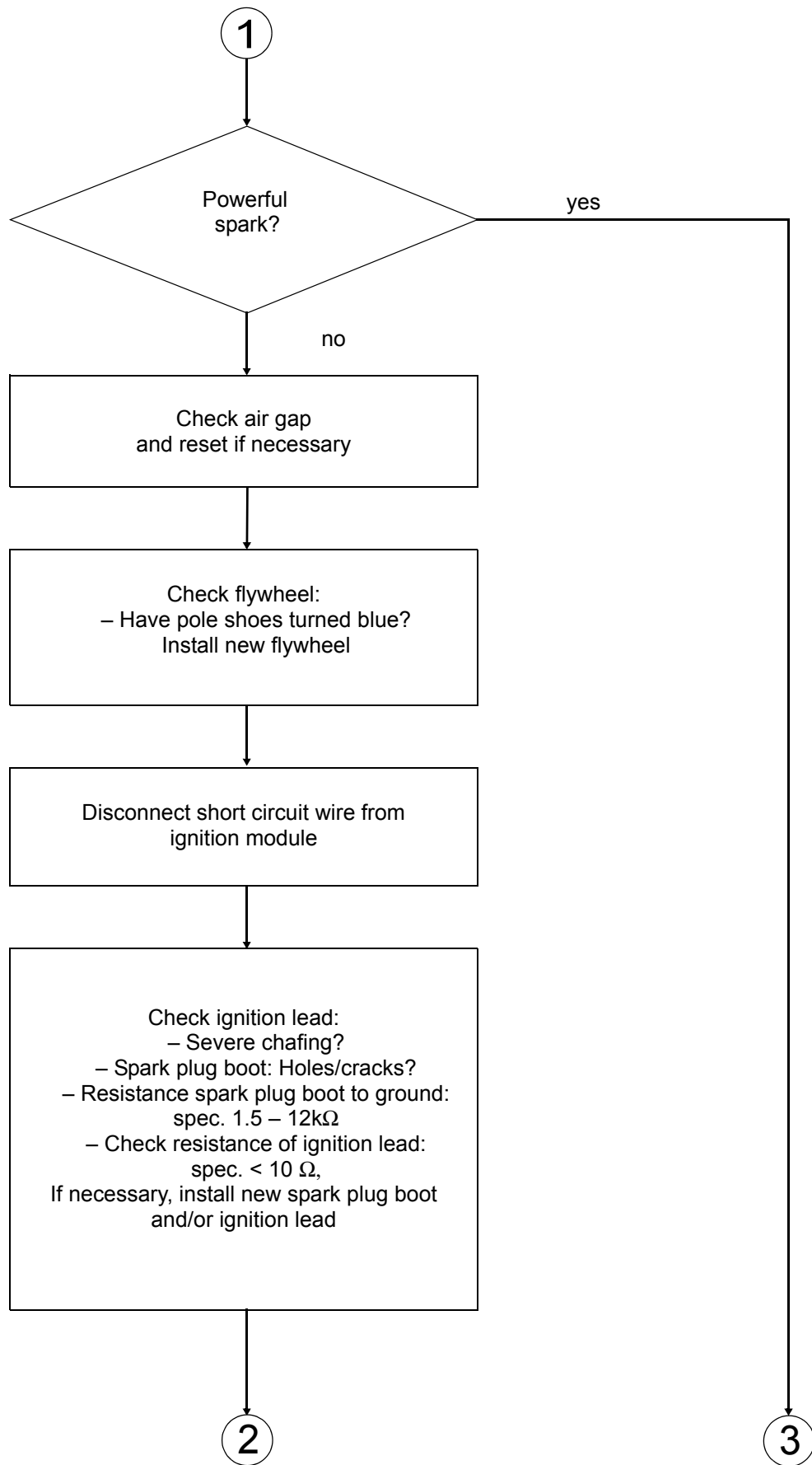

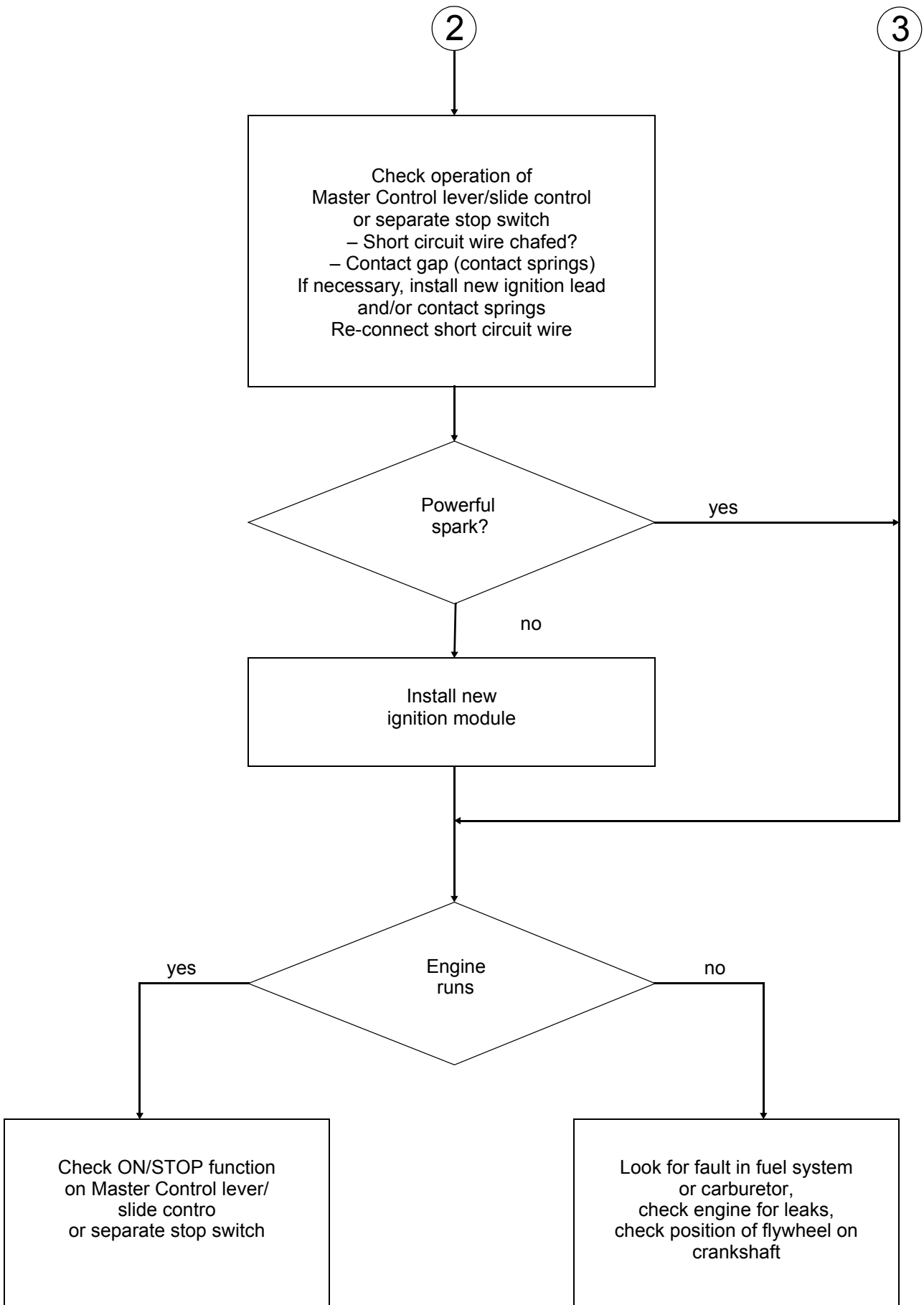

8. Rewind Starter

8.1 General

If the action of the starter rope becomes very stiff and the rope rewinds very slowly or not completely, it can be assumed that the starter mechanism is in order but plugged with dirt. At very low outside temperatures the lubricating oil on the rewind spring may thicken and cause the spring windings to stick together. This has a detrimental effect on the function of the starter mechanism. In such a case it is sufficient to apply a few drops of paraffin (kerosine) to the rewind spring.

Carefully pull out the starter rope several times and allow it to rewind until its normal smooth action is restored.

If clogged with dirt or pitch, the entire starter mechanism, including the rewind spring, must be removed and disassembled. Take special care when removing the spring.

Wash all parts in STIHL cleaner.

Lubricate the rewind spring and starter post with STIHL special lubricant,  13, before installing.

8.2 Removing and Installing

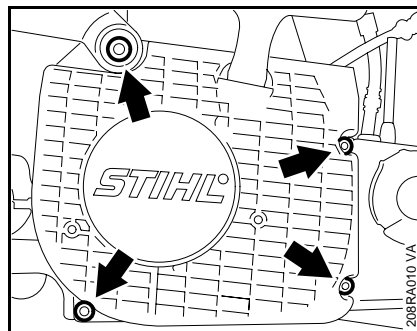

- Remove the screws (arrows) from the fan housing and hand guard.

- Lift away the fan housing with rewind starter.

Reassemble in the reverse sequence.

- Tighten down screws to 6 Nm (4.4 lbf.ft).

8.3 Rope Rotor

Troubleshooting chart –  4.2.

- Remove the fan housing –  8.2.

Relieving tension of rewind spring:

The rewind spring will not be under tension if the starter rope is broken.

- Pull out the starter rope about 5 cm (2") and hold the rope rotor steady.
- While still holding the rope rotor steady, take three full turns off the rope rotor.
- Pull out the rope with the starter grip and slowly release the rope rotor.

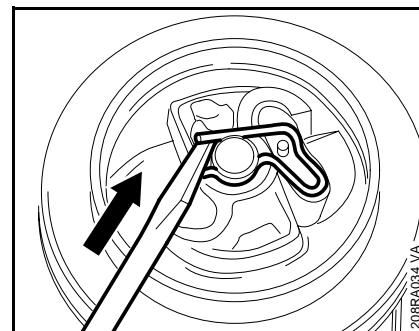

Removing the rope rotor:

- Use a screwdriver or suitable pliers to carefully remove the spring clip from the starter post.

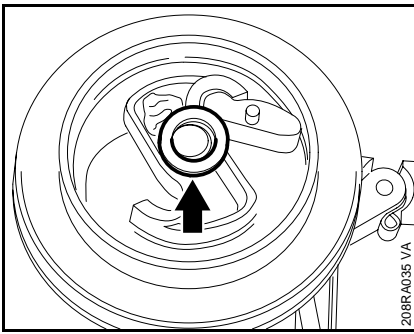

- Remove the washer (arrow).

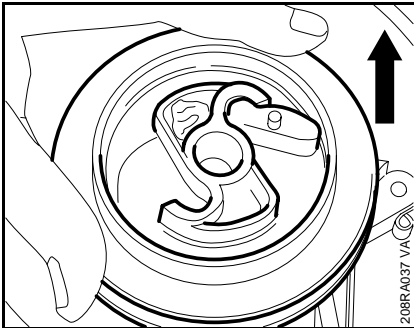

- Carefully pull the rope rotor off the starter post.
- To replace the rope rotor, first remove the starter rope – [8.5](#).

The rewind spring may pop out and unwind if rope rotor is not removed very carefully.

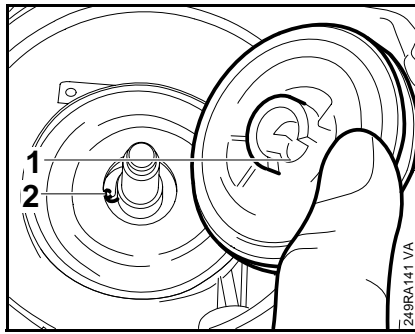

Installing the rope rotor:

Coat bore in rope rotor with STIHL special lubricant – [13](#).

- Fit the rotor on the starter post so that the lug (1) on the rope rotor slips behind the inner spring loop (2).

Check that spring loop has engaged by turning rope rotor slightly and letting it go – it must spin back.

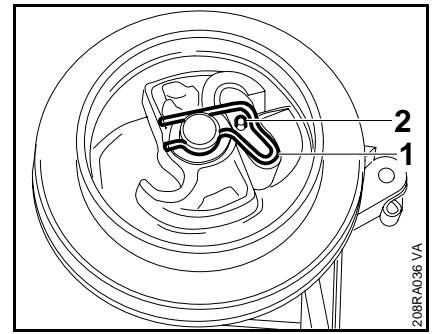

- Fit washer and push the spring clip into the groove in the starter post.

Make sure the spring clip (1) engages the pawl guide peg (2) and points in the clockwise direction.

The spring clip must be handled very carefully. If it is bent during disassembly or assembly, the rewind starter may not function properly.

- Install the starter rope – [8.5](#).
- Tension the rewind spring – [8.5.2](#).

– Remove the rope rotor –  8.3.

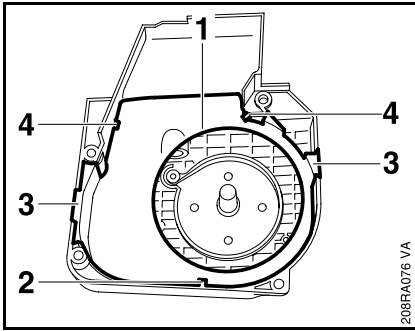

- Use a screwdriver to pry the segment (1) out of the upper retainers (4).

– Pull the segment upwards and remove.

Reassemble in the following sequence.

- Place the segment (1) in position and push it under the retainer (2).
- Engage lugs (3) flush with housing.
- Push segment into retainers (4).

Reassemble all other parts in the reverse sequence.

Remove the rope rotor –  8.3.

– Remove the remaining rope from the rope rotor and the starter grip.

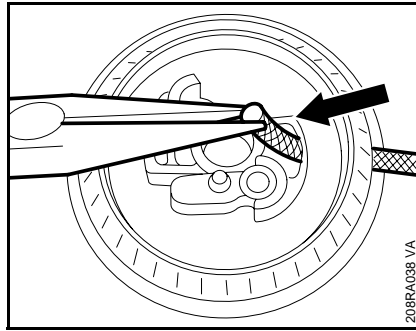

- Thread end of new rope through the hole in the side of the rotor, pull it out.

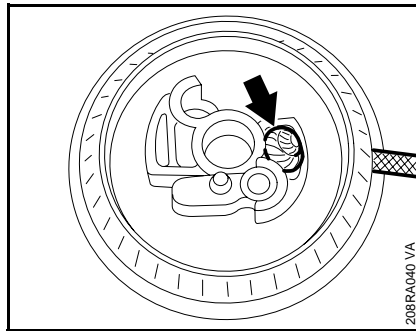

– Secure the rope with a simple overhand knot.

- Pull the rope back until the knot locates in the recess (arrow) in the rope rotor.

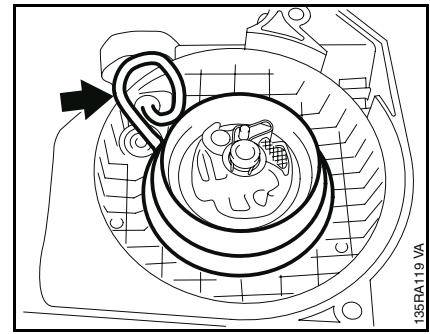

- Thread the other end of the rope through the guide bush from inside.

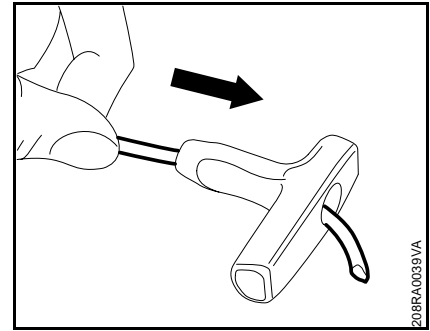

- Then through the underside of the starter grip and pull it out.

8.5.1 Elastostart

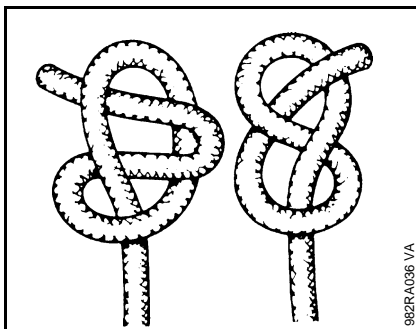

- Tie one of the special knots shown.
- Pull the rope back into the starter grip.
- Install the rope rotor – 8.3.
- Tension the rewind spring – 8.5.2.

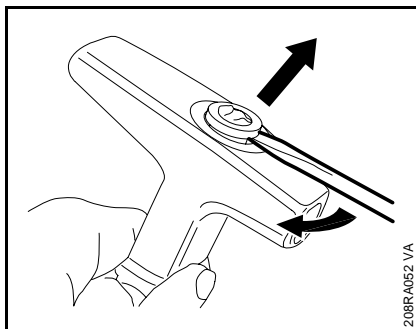

- Pry the nipple of the starter rope out of the starter grip. Pull out the starter rope.

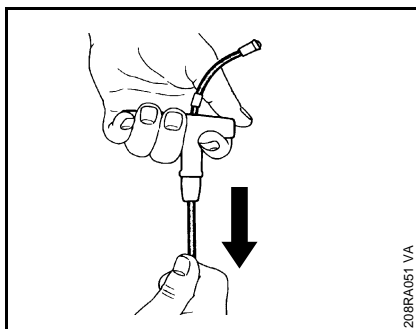

- Thread new starter rope through the top of the starter grip.

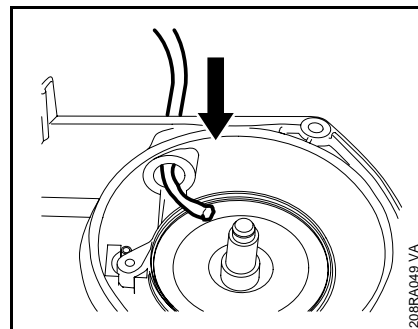

- Thread the other end of the rope, from outside, through the guide bush in the fan housing.
- Fit the rope in the rope rotor – 8.5.
- Install the rope rotor – 8.3.
- Fit the fan housing – 8.2.

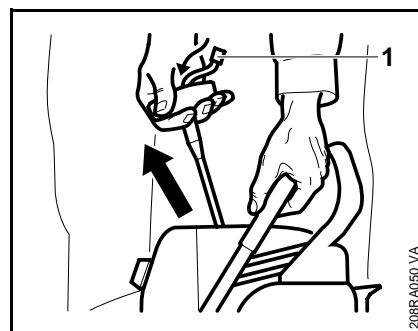

- Pull out the starter rope until the nipple (1) locates in the starter grip.

8.5.2 Tensioning

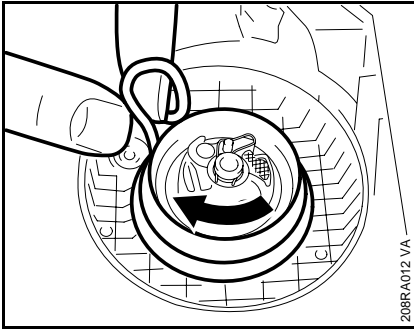

- Make a loop in the starter rope.

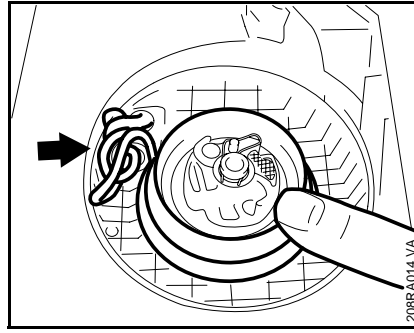

- Hold the rope rotor steady.
- Pull out the rope with the starter grip and straighten it out.
 - Hold the starter grip firmly to keep the rope tensioned.
 - Let go of the rope rotor and slowly release the starter rope so that it can rewind properly.

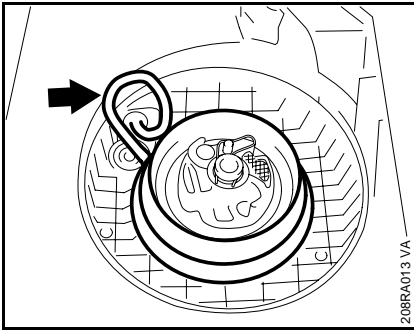

- **Grip** the rope next to the rotor and use it to turn the rope rotor six times clockwise.

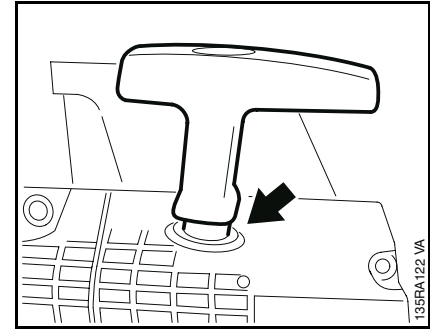

The rewind spring is correctly tensioned when the starter grip sits firmly in the rope guide bush without drooping to one side. If this is not the case, tension the spring by one additional turn.

When the starter rope is fully extended, it must still be possible to rotate the rope rotor at least another half turn before maximum spring tension is reached. If this is not the case, pull the rope out, hold the rope rotor steady and take off one turn of the rope.

Do not overtension the rewind spring as this will cause it to break.

- Fit the fan housing –  8.2.

8.6 Rewind Spring

– Remove the rope rotor –  8.3.

The replacement spring comes ready for installation and is secured with a frame.

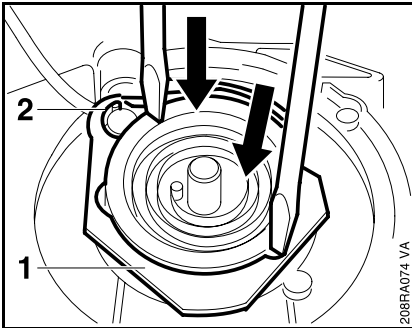

– Lubricate the spring with a few drops of STIHL special lubricant before installation –  13.

- The frame (1) slips off as the rewind spring is pushed into the fan housing. Press the anchor loop (2) into the recess in the fan housing at the same time.

The rewind spring may pop out and uncoil during installation.

– If the rewind spring has popped out, refit it in the assembly tool 1116 893 4800 as follows:

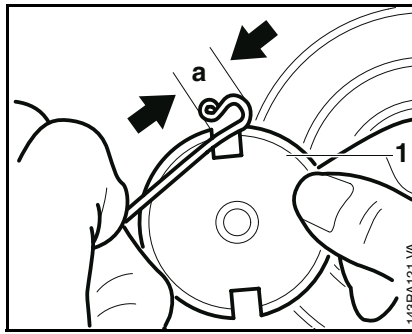

- Position the anchor loop about 20 mm (3/4") (dimension 'a') from the edge of the assembly tool.

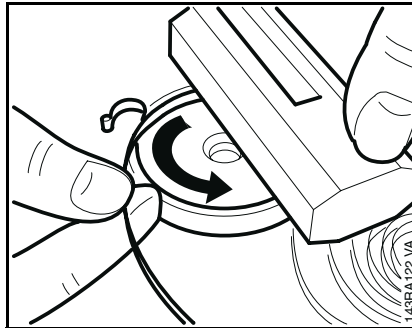

- Fit the rewind spring in the counterclockwise direction, starting from outside and working inwards.
- Place wooden block 1108 893 4800 over the assembly tool to simplify this operation.
- Slip the assembly tool with rewind spring over the starter post.

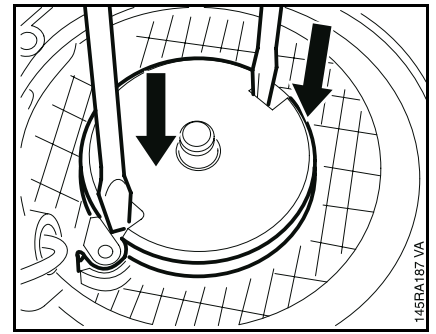

- Push the rewind spring into the fan housing and then remove the assembly tool.

– Install the rope rotor –  8.3.

– Tension the rewind spring –  8.6.

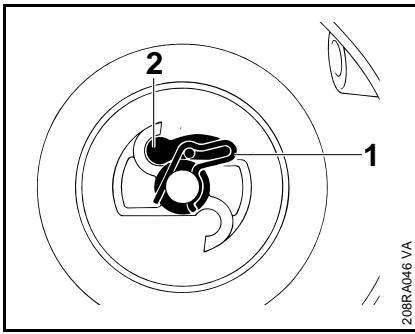

- Remove the spring clip (1) from the starter post.

Do not take the rope rotor off the starter post.

- Pull the pawl (2) out of the rope rotor.
- Coat peg of new pawl with graphite grease – 13.

Reassemble in the reverse sequence.

9. AV Handle System/ Handle Housing

9.1 Annular Buffers

Rubber anti-vibration buffers are installed between the handle and engine housing, handle housing and front handle. Damaged rubber buffers (annular buffers) must always be replaced.

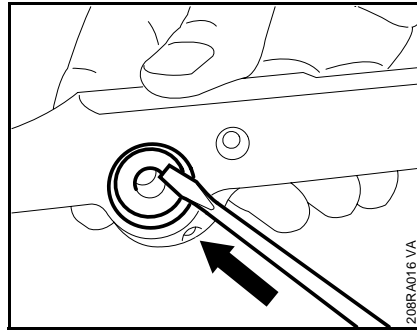

Annular buffers in front handle

- Remove the front handle – 9.2.
- Pry both annular buffers out of the front handle.

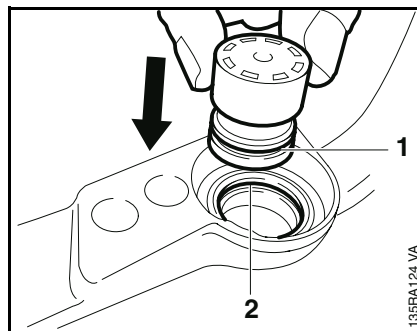

- Push home the annular buffer from inside the front handle until its groove (1) engages over the housing rib (2).

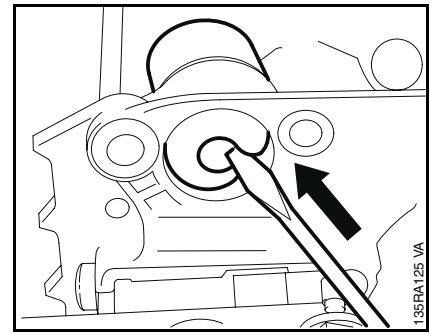

Annular buffer in engine housing

- Front handle removed.
- Pry the annular buffer out of the engine housing.

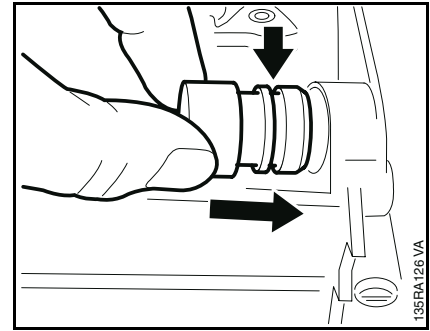

- Push annular buffer into the engine housing until its groove engages over the housing rib.
- Fit the front handle.

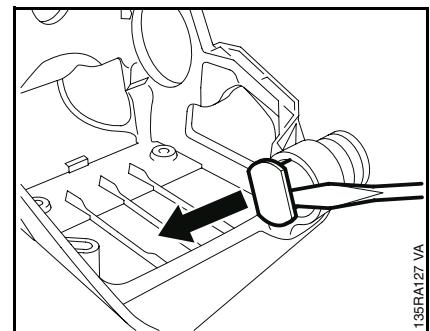

Annular buffer in handle housing

- Remove the handle housing – 9.3.
- Ease the plug out of the buffer.

9.2 Front Handle

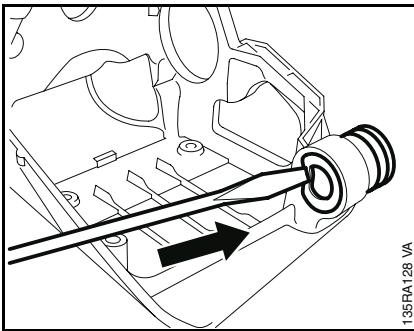

- Pry the annular buffer out of the handle housing.

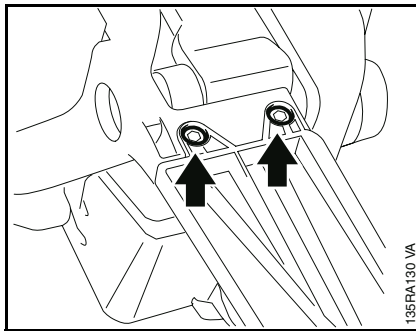

- Take the lower mounting screws out of the front handle.

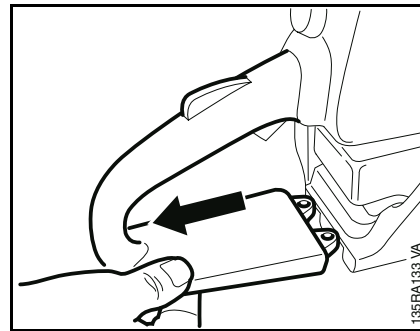

- Pull the lower part of the handle housing out of the front handle.

– Remove the front handle.

Reassemble in the reverse sequence.

– Tighten down screws in annular buffers to 3.5 Nm (2.6 lbf.ft).

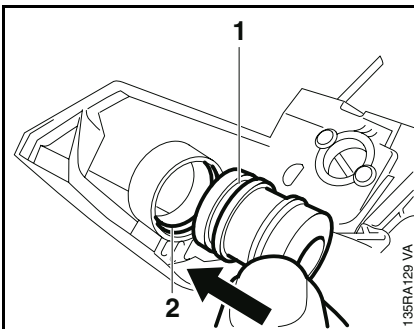

- Push the annular buffer into the handle housing from outside until its groove (1) engages over the rib (2).

– Install the handle housing –
 9.3.

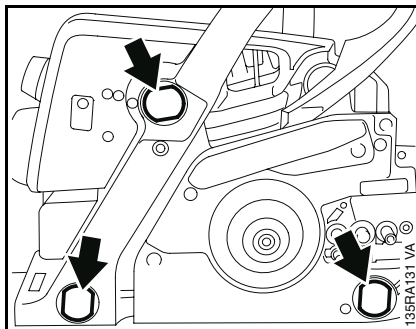

– Remove lower bumper strip from the tensioner.

- Ease plugs out of the annular buffers.

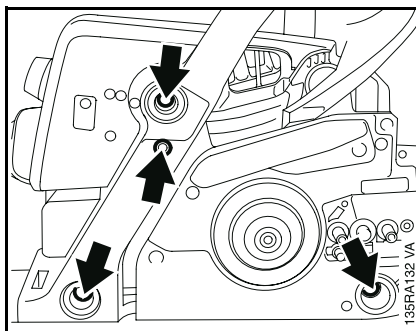

- Take out the screws.

9.3 Handle Housing

- Remove the front handle –
📖 9.2.
- Remove the fan housing –
📖 8.2.
- Remove the muffler – 📖 6.1.
- Remove the carburetor –
📖 11.2.2.

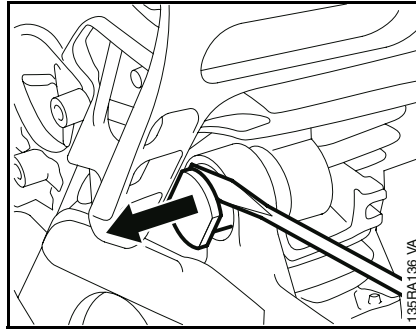

- Ease the plug out of the annular buffer.

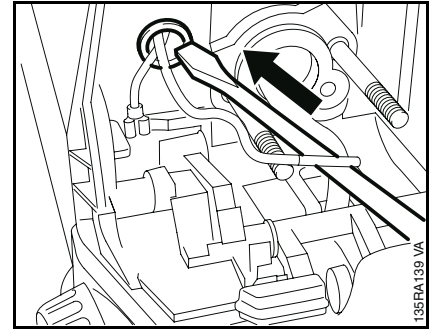

- Push the grommet out of the handle housing.
- Pull the ground and short circuit wires out of the bore.

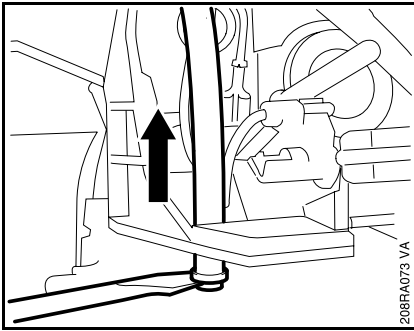

- Disconnect tank vent hose from the stub.

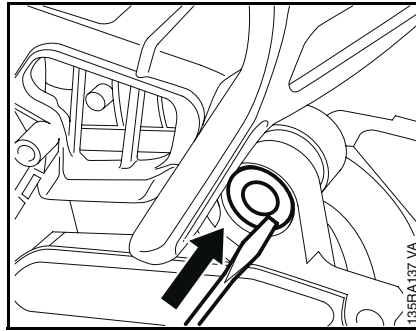

- Pry the annular buffer out of the engine housing.

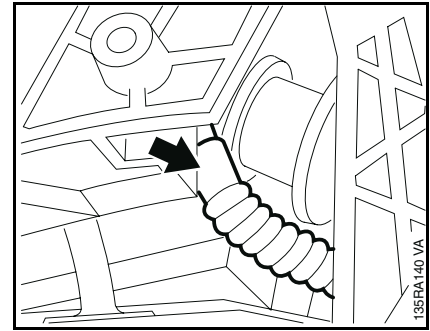

- Pull the impulse hose off the stub on the handle housing.

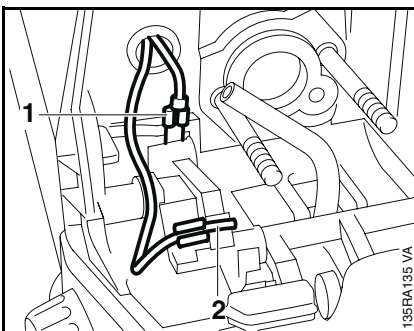

- Pull the ground wire (1) off the contact spring.
- Pull the short circuit wire's contact sleeve (2) out of the switch shaft.

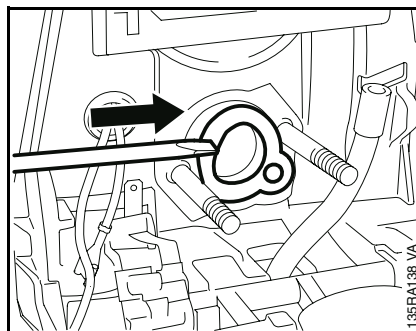

- Pull the handle housing slightly forward and push the manifold through the handle housing opening at the same time.

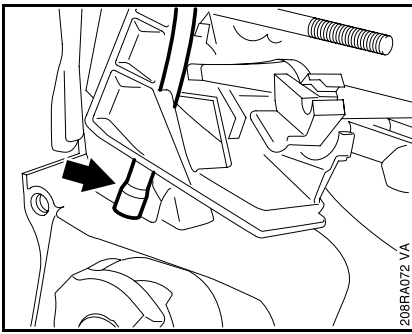

- On easy start machines, pull manual fuel pump hose (arrow) out of the fuel tank.
- Remove the handle housing.
- To replace, remove the annular buffers – 9.1.
- Remove the switch shaft – 9.4.
- Remove the throttle trigger – 9.6.
- Remove the contact spring – 9.5.
- On easy start machines, remove the manual fuel pump – 11.6.

Reassemble in the reverse sequence.

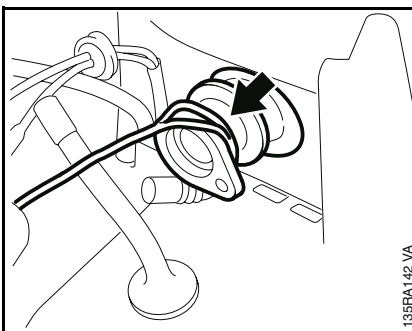

- To fit the manifold in the handle housing intake opening, wind a piece of string (about 15 cm / 6" long) around the back of the manifold flange.

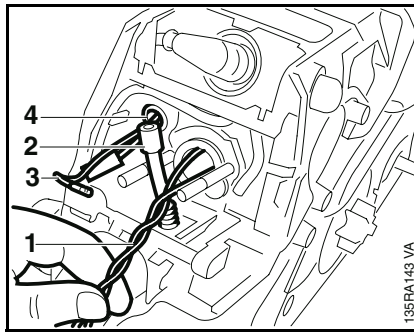

- Place the handle housing in position and pass the string (1), fuel hose (2), ground wire (3) and short circuit wire (4) through the openings.

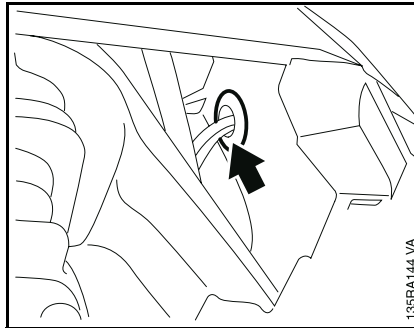

- Push the grommet for the ground and short circuit wires into the bore from inside.

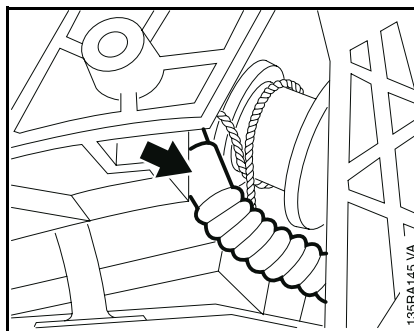

- Connect the impulse hose to the stub on the handle housing.

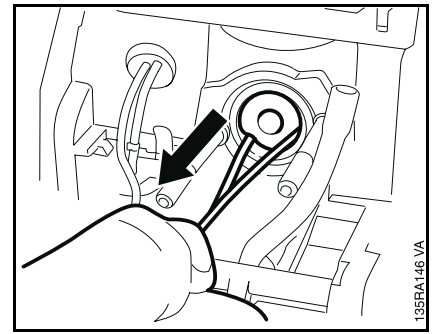

- Pull the ends of the string outward.

The manifold flange is thus pulled through the handle housing intake opening without any damage to the manifold.

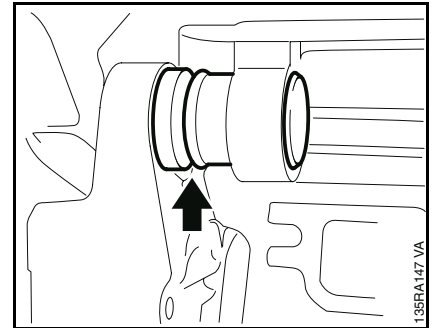

- Push the annular buffer into the engine housing until its groove engages over the housing rib.

Reassemble all other parts in the reverse sequence.

9.4 Switch Shaft

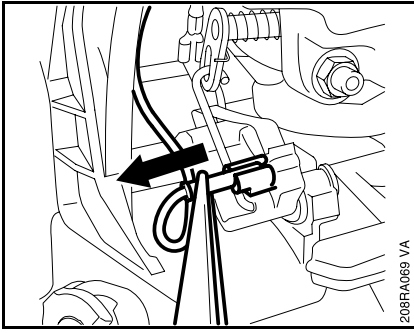

- Remove the carburetor box cover –  11.1.
- Pull the contact sleeve out of the switch shaft.

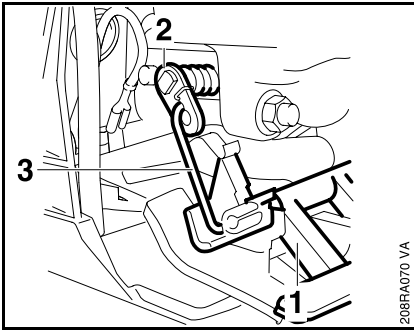

- Move the Master Control lever (1) until the slot in the choke shaft (2) and the choke rod (3) are in line.

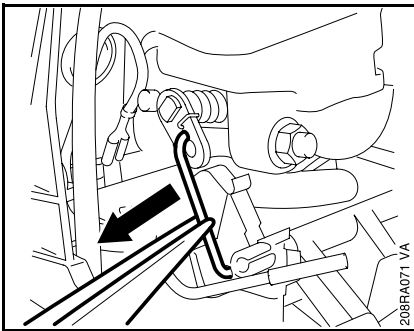

- Pull the choke rod out of the switch shaft and the choke shaft.

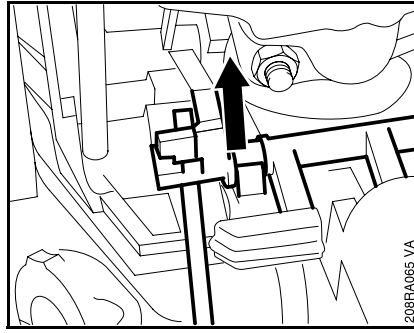

- Set the Master Control lever to the horizontal position and pry the switch shaft out of its pivot mount.

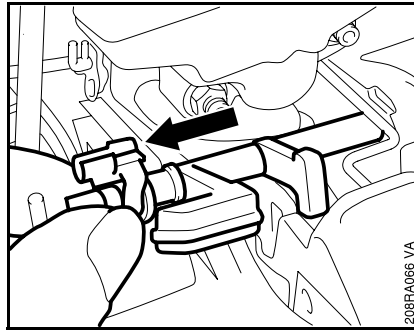

- Pull the switch shaft out of its bore.

Install in the reverse sequence.

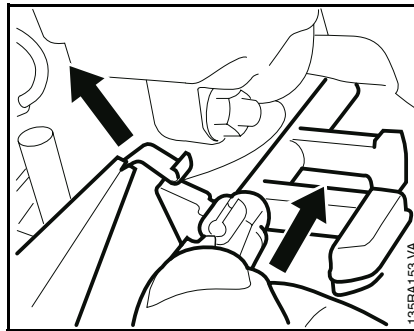

- Lift the contact spring slightly to install the switch shaft.

9.5 Contact Spring

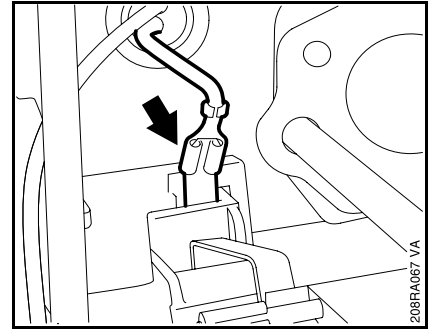

- Remove the carburetor –  11.2.2.

- Pull the ground wire terminal off the contact spring.

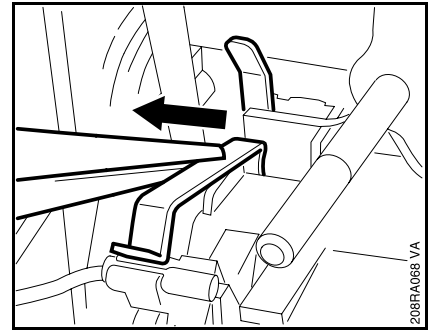

- Pull the contact spring out its seat in the handle housing.

Install in the reverse sequence.

9.6 Throttle Trigger/ Interlock Lever

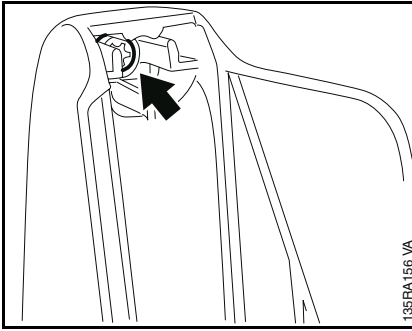

- Remove the carburetor box cover –  11.1.
- Take out the screw.
- Swing the handle molding up and lift it away.

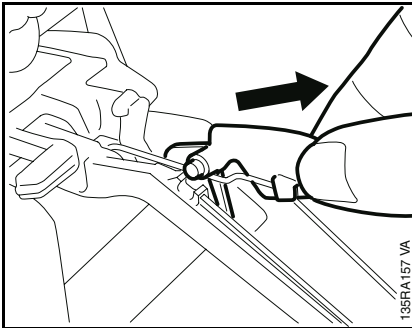

- Move the Master Control lever to the normal "RUN" position.
- Pull the interlock lever out of its seat.

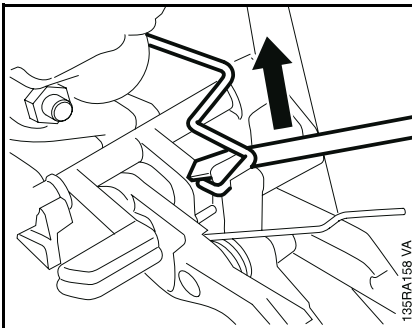

- Remove the throttle rod from the throttle trigger.

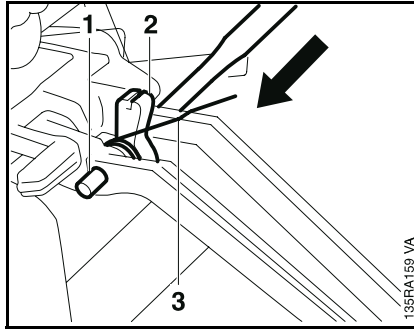

- Use a 4 mm (5/32") drift to drive out the cylindrical pin (1).
- Remove the throttle trigger (2) and torsion spring (3).

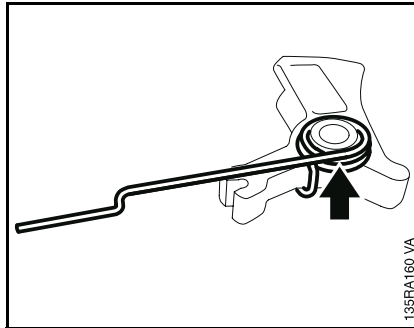

- Take the torsion spring off the throttle trigger.

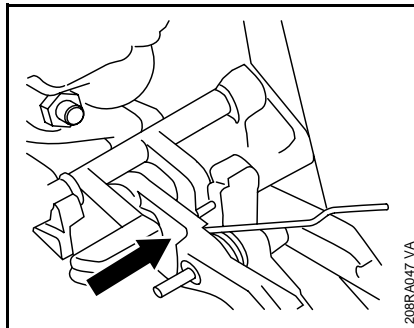

- Fit the throttle trigger so that the seat for the throttle rod points upward.
- Use a 4 mm (5/32") drift to push home the cylindrical pin.

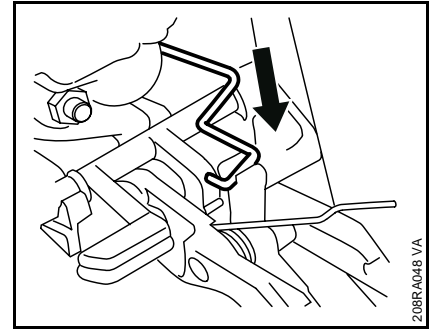

- Push the throttle rod into the throttle trigger.

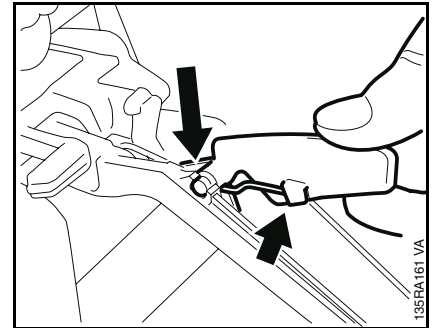

- Press the interlock lever into the slots. The torsion spring must be under the interlock lever and engage the notch.

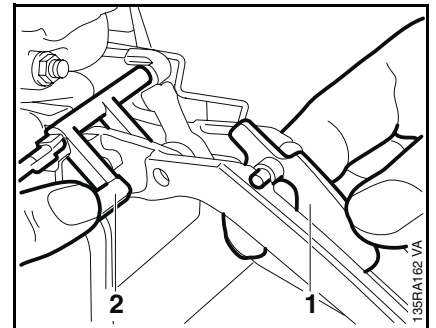

- Press the interlock lever (1) downward.
- Push the throttle trigger upward and move the Master Control lever (2) to the "Choke" position.

10. Chain Lubrication

10.1 Pickup Body

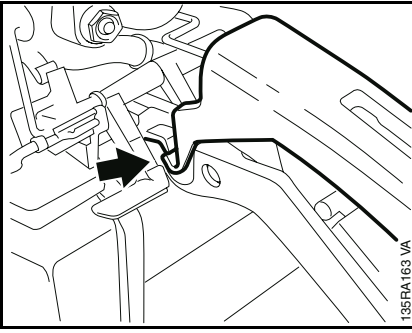

- Fit the handle molding so that it engages behind the lugs as shown.
- Insert screw and tighten down to 1.6 Nm (1.2 lbf.ft).
- Fit the carburetor box cover –  11.1.

Impurities gradually clog the fine pores of the filter with minute particles of dirt. This prevents the oil pump from supplying sufficient oil to the bar and chain. In the event of problems with the oil supply system, first check the oil tank and the pickup body. Clean the oil tank if necessary.

Troubleshooting chart –  4.3.

- Unscrew oil filler cap and drain the oil tank.

Collect chain oil in a clean container or dispose of it properly at an approved disposal site.

- Observe safety precautions –  2.

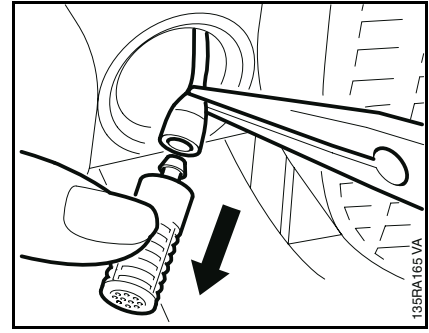

- Pull the pickup body out of the oil suction hose.
- Wash the pickup body in STIHL cleaner and, if possible, blow out with compressed air.
- Replace pickup body if it is damaged.
- Flush out the oil tank.

Install in the reverse sequence.

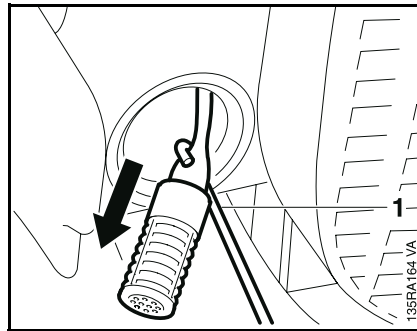

- Use hook (1) 5910 893 8800 to withdraw the pickup body from the oil tank.

Avoid stretching the oil suction hose.

10.2 Connector/ Suction Hose

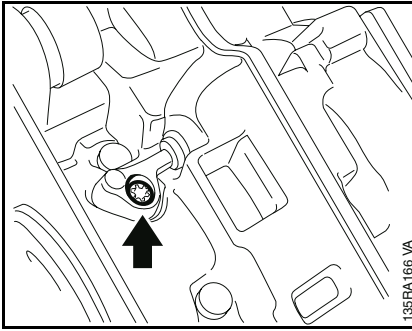

- Remove the front handle –
📖 9.2.
- Take out the screw.

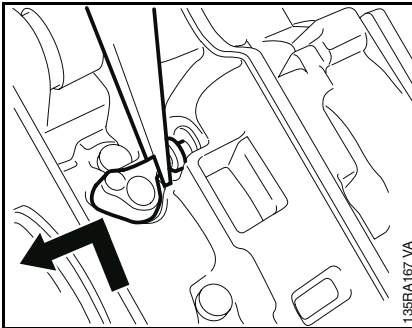

- Pull the connector out of the oil pump and suction hose.

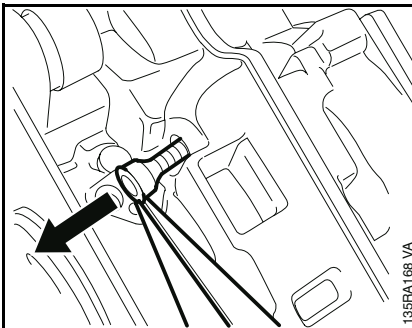

- Pull suction hose with pickup body out of the oil tank.
- Remove the pickup body.

10.3 Valve

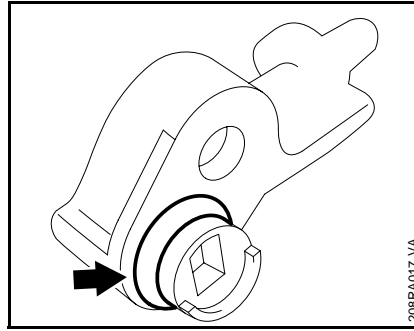

Install in the reverse sequence.

- Fit new O-ring on connector (see arrow).
- Tighten down screw to 4.0 Nm (3.0 lbf.ft).

A vent valve is installed in the tank wall to keep the internal pressure in the oil tank equal to atmospheric pressure.

Cleaning the valve

- Unscrew the oil filler cap.
- Drain the oil tank.

Collect chain oil in a clean container or dispose of it properly at an approved disposal site.

- Observe safety precautions –
📖 2.
- Use compressed air to blow valve clear from the outside inwards.
- Flush the oil tank.
- Fit the oil filler cap.

Replacing the valve

- Unscrew the oil filler cap.

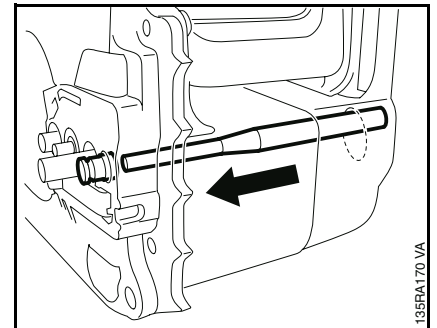

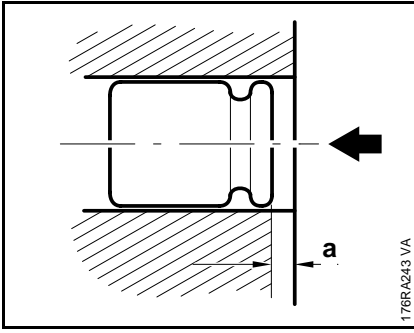

- Use a 5 mm (3/16") dia. drift to carefully drive the valve out of the housing from inside the tank.

10.4 Worm

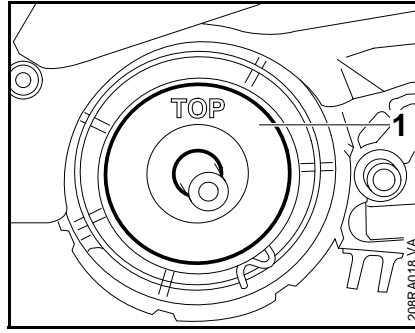

- Use a 7 mm (9/32") dia. drift to carefully push home the new valve until dimension 'a' is about 1 mm (3/64").
- Fit the oil filler cap.



- Remove the clutch –  8.
- Remove the cover washer (1).

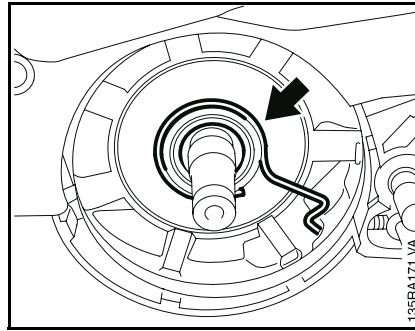

- Pull the worm and drive spring (arrow) off the crankshaft stub.

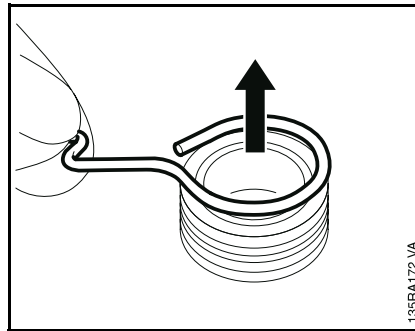

- Take the drive spring off the worm.

Reassemble in the reverse sequence.

Fit the cover washer so that the word "TOP" faces outwards.

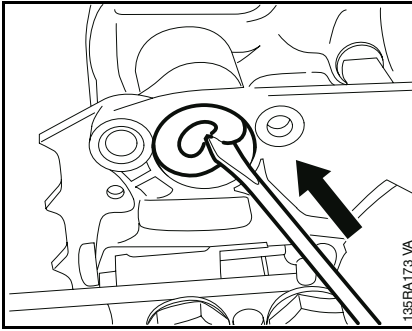

Removing

- Remove the connector –  10.2.
- Pry out the lower annular buffer.

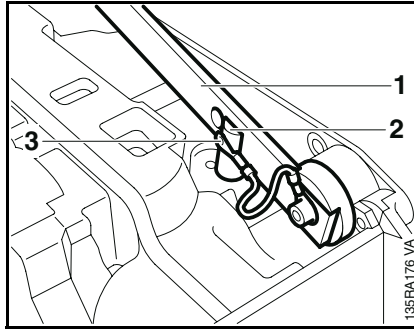

- Swing lever (1) down into fork head (2) and secure it with the connecting pin (3).

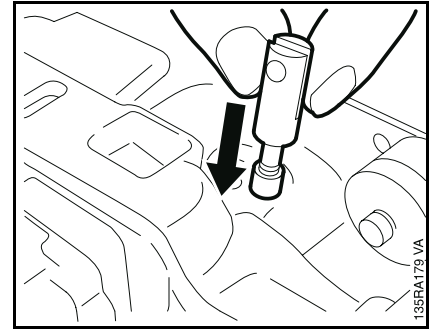

- Place the fork head (1123/01) with the straight stem (from installing tool) in the oil pump.
- Fit lever in fork head and secure in position.

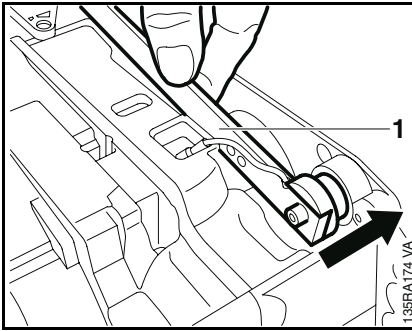

- Fit lever (1) of installing tool 1123 890 2201 in the bore for the annular buffer – from inside.

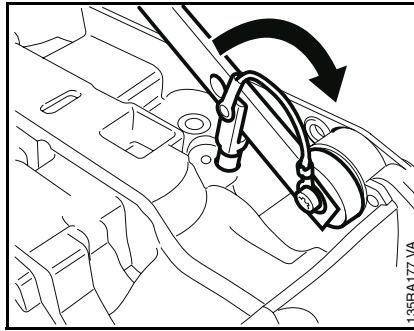

- Swing lever upward to pull the oil pump out of the housing.
- Unscrew the oil pump from the fork head.

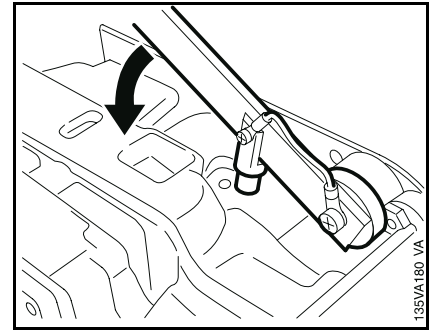

- Press the lever down until the fork head butts against the engine housing. The oil pump is now installed at the right depth.
- Remove the lever.

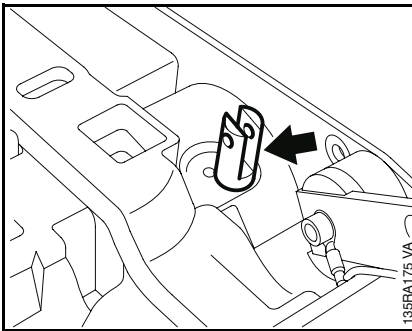

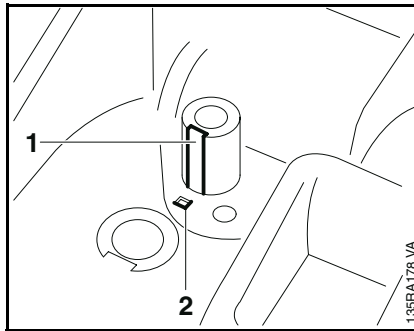

- Screw fork head (1123) with threaded stem (from installing tool) into the oil pump.

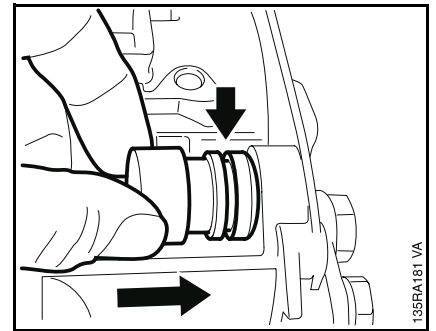

Installing

- Place the oil pump in position so that its groove (1) lines up with the square (2) on the housing.



- Push the annular buffer into the housing until its groove engages over the housing rib.
- Fit the connector –  10.2.

11. Fuel System

11.1 Air Filter

Dirty air filters reduce engine power, increase fuel consumption and make starting more difficult.

The air filter should always be cleaned when there is a noticeable loss of engine power.

- Close the choke shutter.

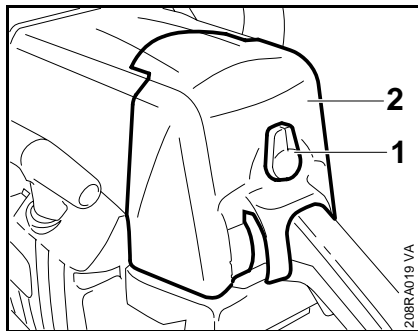

- Turn twist lock (1) 90 degrees counterclockwise.
- Lift off the carburetor box cover (2) vertically.
- Remove all loose dirt from around the filter.

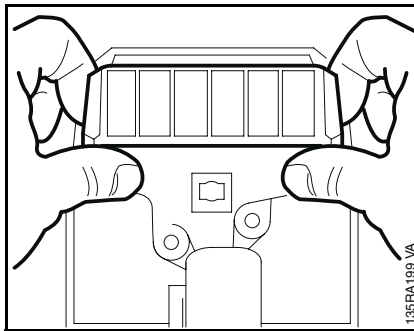

Fabric/fleece filter

- Place fingers behind the filter, press thumbs against housing, and swing filter toward rear handle.
- Remove the filter.
- Use compressed to blow out filter from the clean air side.
- If the filter is caked with dirt or no compressed air is available, wash the filter in a fresh, non-flammable cleaning solution (e.g. warm soapy water) and then dry.

Replace a damaged air filter.

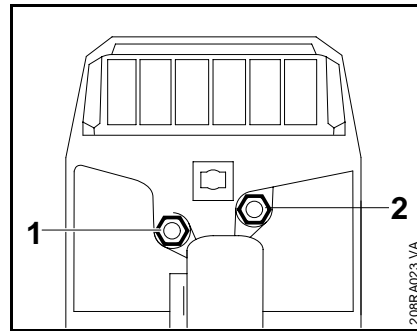

- To remove the filter housing, unscrew the nuts (1 and 2) and lift the filter housing away.

Reassemble in the reverse sequence.

- Tighten down nuts to 2.7 Nm (2.0 lbf.ft).
- Push air filter onto filter housing until it snaps into position.

11.2 Carburetor

11.2.1 Leakage Test

Troubleshooting chart –  4.5.

If problems occur on the carburetor or the fuel supply system, always check and clean the tank vent –  11.3.

The carburetor can be tested for leaks with the carburetor and crankcase tester 1106 850 2905.

- Remove the carburetor box cover –  11.1.

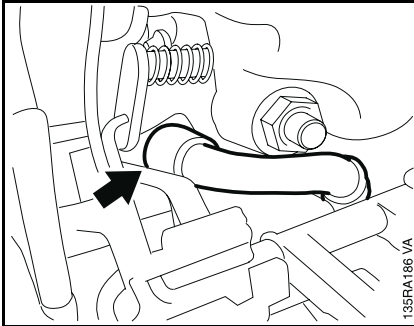

- Pull fuel hose (arrow) off the carburetor's elbow connector.

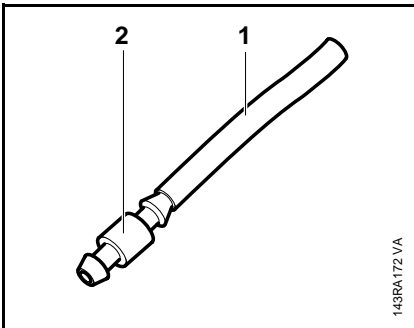

- Push the fuel line (1) 1110 141 8600 onto the nipple (2) 0000 855 9200.

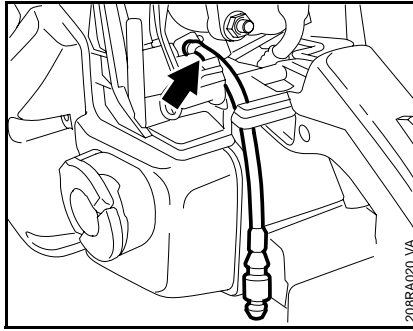

- Push fuel line with nipple onto carburetor elbow connector (arrow).

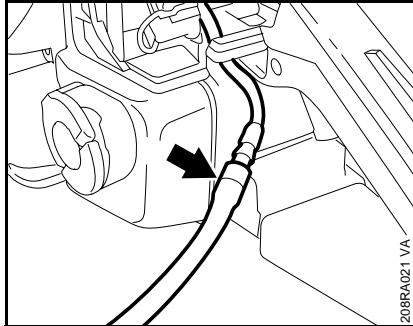

- Connect the tester's pressure hose to the nipple.

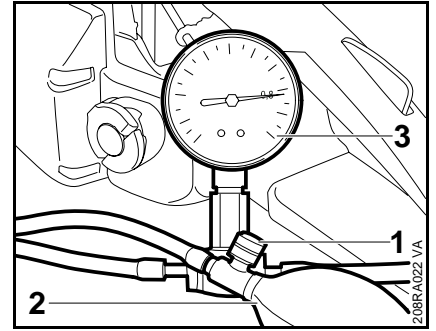

- Close the vent screw (1) on the rubber bulb (2) and pump air into the carburetor until the pressure gauge (3) shows a reading of approx. 0.8 bar (11.6 psi).

If this pressure remains constant, the carburetor is airtight. However, if it drops, there are two possible causes:

1. The inlet needle is not sealing (foreign matter in valve seat or sealing cone of inlet needle is damaged or inlet control lever sticking).

2. The metering diaphragm is damaged.

– After completing test, open the vent screw and pull the fuel line off the elbow connector.

– Push the fuel hose onto the elbow connector.

– Fit the carburetor box cover.

11.2.2 Removing and Installing

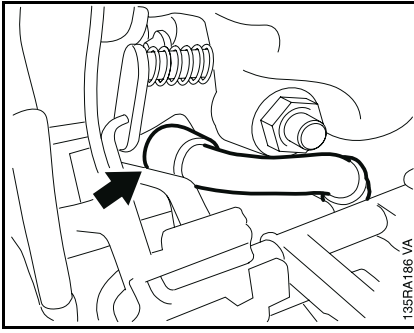

- Remove the air filter –  11.1.
- Pull fuel hose (arrow) off the carburetor's elbow connector.

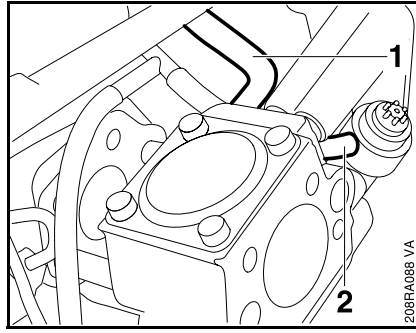

- Disconnect fuel hose (1) from the manual fuel pump, if fitted.
- Pull the hose (2) off the tank vent.

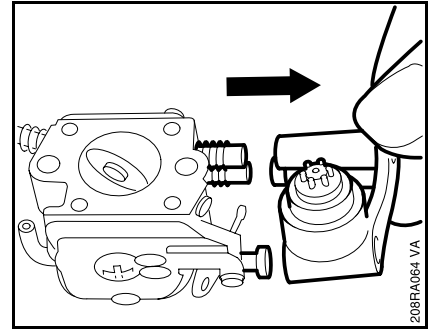

- Remove the grommet with tank vent from the adjusting screws.

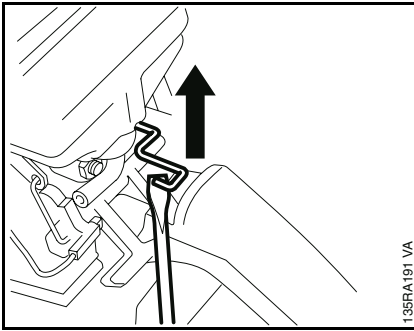

- Detach throttle rod from the throttle trigger.

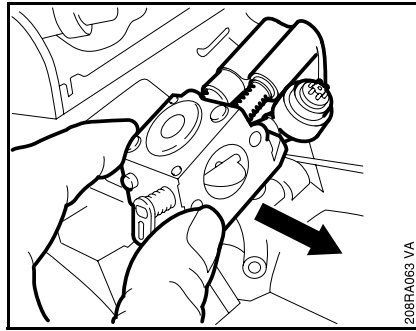

- Remove the carburetor.

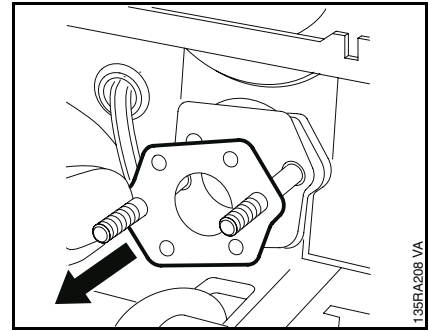

- Slip the gasket off the studs.
- If necessary, remove the shim from the studs.

Reassemble in the reverse sequence.

- Fit the shim with its flat side facing outward.
- Install a new gasket.
- Tighten down locknuts to 2.5 Nm (1.8 lbf.ft).

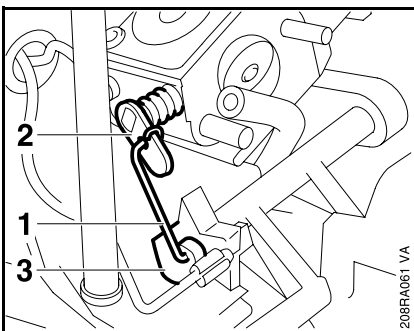

- Pull choke rod (1) out of choke shaft (2) and switch shaft (3).
- On easy start machines, pull carburetor forward a little.

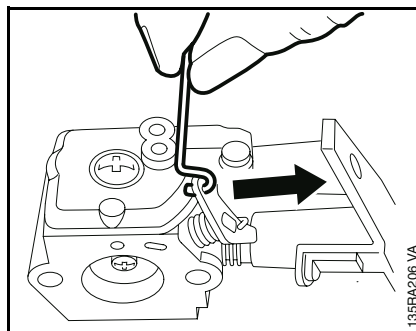

- Take the throttle rod off the throttle shaft.

11.2.3 Adjusting (Carburetor without Limiter Cap)

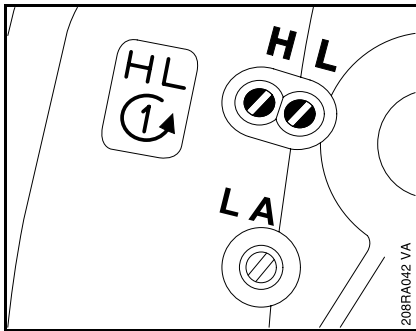

Standard setting (without tachometer)

To readjust the carburetor, start with the standard setting.

- Carefully screw down both adjusting screws (H and L) until they are against their seats.

Then make the following adjustments:

- Open high speed screw (H) one full turn.
- Open low speed screw (L) one full turn.

If no tachometer is available, do not turn the high speed screw (H) beyond the standard setting to make the mixture leaner.

Standard setting (with tachometer)

- Check the air filter and clean or replace as necessary.
- Check chain tension.
- Warm up the engine.
- Adjust idle speed.

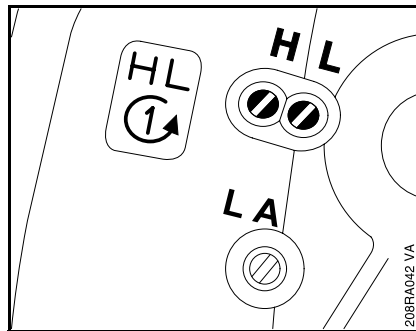

Adjusting engine idle speed

- Adjust idle speed with a tachometer. Adjust specified engine speeds within tolerance of +/- 200 rpm.

1. Adjust engine speed with idle speed screw (LA) to 3,300 rpm.
2. Turn low speed screw (L) clockwise or counterclockwise to obtain maximum engine speed.

If this speed is higher than 3,700 rpm, abort the procedure and start again with step 1.

3. Use the idle speed screw (LA) to set engine speed again to 3,300 rpm.

4. Set the engine speed to 2,800 rpm with the low speed screw (L).

Starting from the standard setting, use the high speed screw (H) to adjust the maximum engine speed to:

- 12,500 rpm (MS 210)
- 14,000 rpm (MS 230, 250)

If the setting is **too lean** there is a risk of engine damage due to insufficient lubrication and overheating.

11.2.4 Adjusting (Carburetor with Limiter Cap)

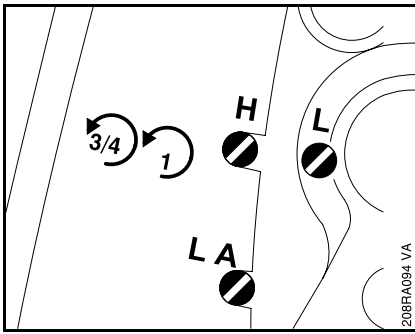

Standard setting

Do not remove the limiter cap to carry out the standard setting.

- With this carburetor it is only possible to correct the setting of the high speed screw (H) within fine limits.

Make the following adjustments:

- Turn high speed screw (H) counter-clockwise (max. 3/4 turn) as far as stop.
- Screw low speed screw (L) down onto its seat clockwise, then open it one full turn from that position.

Adjusting engine idle speed

- Check the air filter and clean or replace as necessary.
- Check chain tension.
- Warm up the engine.

Adjust idle speed with a tachometer. Adjust specified engine speeds within tolerance of +/- 200 rpm.

1. Adjust engine speed with idle speed screw (LA) to 3,300 rpm.
2. Turn low speed screw (L) clockwise or counterclockwise to obtain maximum engine speed.

If this speed is higher than 3,700 rpm, abort the procedure and start again with step 1.

3. Use the idle speed screw (LA) to set engine speed again to 3,300 rpm.
4. Set the engine speed to 2,800 rpm with the low speed screw (L).

11.2.5 Standard Setting (Carburetor with Limiter Cap)

The limiter cap needs to be removed from the high speed screw (H) only if it is necessary to replace the high speed screw (H) or clean the carburetor.

After removing the limiter cap it is necessary to carry out the standard setting.

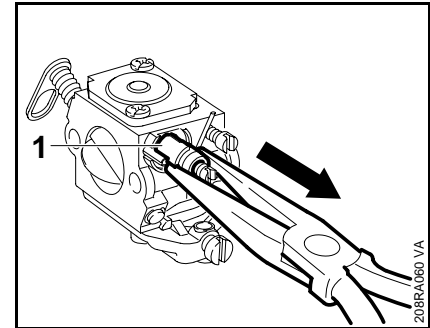

- Use suitable pliers to pull off the limiter cap (1).
- Carefully screw down both adjusting screws (H and L) clockwise until they are against their seats.

Then make the following adjustments:

11.3 Tank Vent

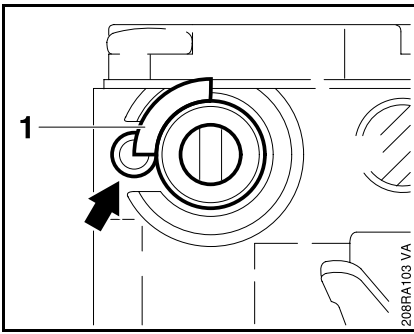

- Open the high speed screw **H** (1) one and one half turns.
- Open the low speed screw **L** (2) one full turn.

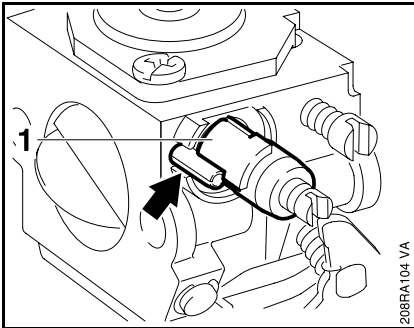

- Position new limiter cap (1) for the high speed screw (**H**) so that it is in line with the rich stop (arrow).
- Push home limiter cap as far as stop against the carburetor body.

Always install a new limiter cap. Limiter caps that have been removed once may be damaged and must not be re-used.

- Adjust engine idle speed –  11.2.4.

Correct operation of the carburetor is only possible if atmospheric pressure and internal fuel tank pressure are equal at all times. This is ensured by the tank vent.

If problems occur on the carburetor or the fuel supply system, also check and clean the tank vent.

Check function by performing pressure and vacuum tests on the tank via the fuel hose.

- Remove the carburetor box cover –  11.1.

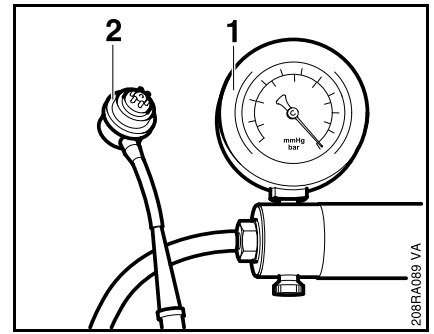

- Connect vacuum pump 0000 850 3501 (1) to tank vent (2) with hose.
- Use vacuum pump to subject vent valve to vacuum.

Equalization of pressure in the fuel tank takes place via the tank vent valve. There must be no build-up of vacuum during the test. In the event of a malfunction, wash the vent valve and hose in STIHL cleaner and blow clear with compressed air. Replace components if necessary.

Reassemble in the reverse sequence.

Make sure the hoses are not kinked.

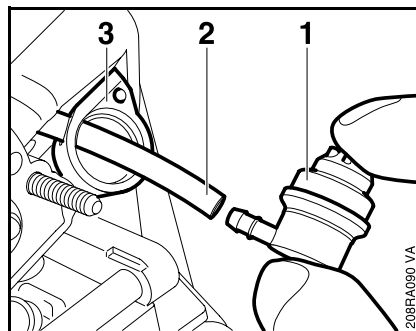

- Take the tank vent valve (1) out of the retainer (3) and pull off the hose (2).

11.4 Pickup Body

The diaphragm pump draws fuel out of the tank and into the carburetor via the fuel hose. Any impurities mixed with the fuel are retained by the pickup body (filter). The fine pores of the filter eventually become clogged with minute particles of dirt. This restricts the passage of fuel and results in fuel starvation.

In the event of trouble with the fuel supply system, always check the fuel tank and the pickup body first. Clean the fuel tank if necessary.

Cleaning the fuel tank

- Unscrew the filler cap and drain the tank.

Observe safety precautions –  2.

- Pour a small amount of clean gasoline into the tank.
- Close the tank and shake the saw vigorously.
- Open the tank again and drain it.

Dispose of fuel properly.

Pickup body

- Unscrew the fuel filler cap and remove it together with the cap retainer, if fitted.

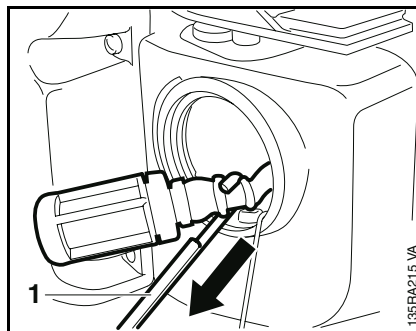

- Use hook (1) 5910 893 8800 to pull the pickup body out of the fuel tank.

Do not stretch the suction hose.

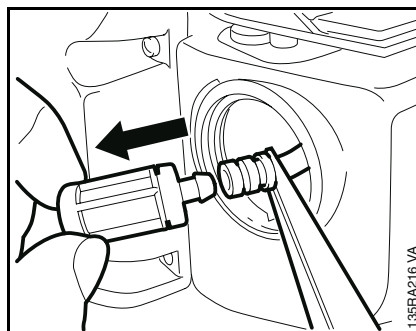



- Pull the pickup body off the fuel hose.
- Fit a new pickup body.

Reassemble in the reverse sequence.

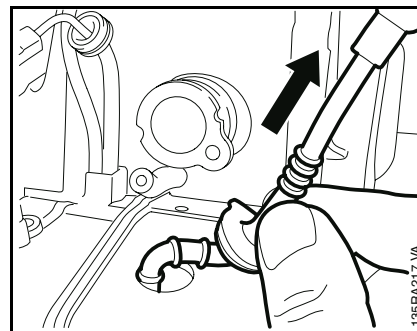
11.5 Suction Hose



- Remove the handle housing –  9.3.

- Remove the pickup body –  11.4.

- Pry suction hose flange out of the fuel tank.

- Pull out the suction hose.

Reassemble in the reverse sequence.

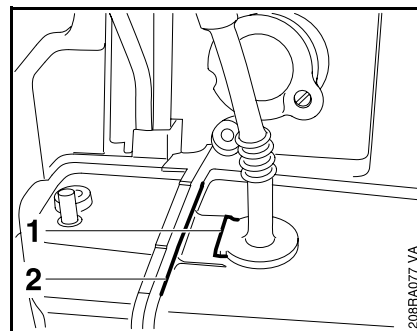

- Coat the hose flange with a little oil to simplify installation.



- Straight side (1) of hose flange must be in line with the tank joint (2).

Reassemble all other parts in the reverse sequence.

Easy start machines only:

- Remove the air filter –  11.1.
- Remove the shutter –  8.
- Remove the spark plug boot.

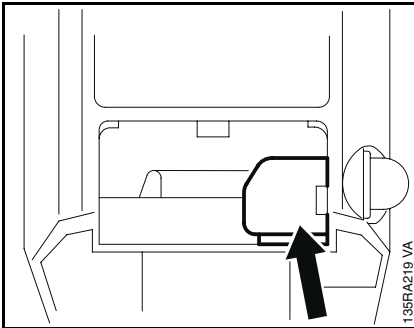

- Carefully push cover, if fitted, with thumb in direction of arrow until it is released from its seat.
- Remove the cover.

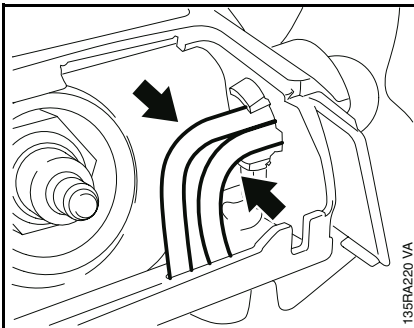

- Disconnect hoses from the connectors.

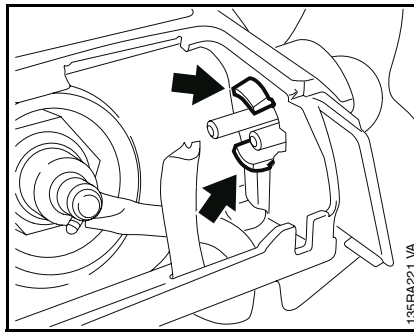

- Carefully squeeze the retaining tabs together.
- Pump the fuel pump out of its seat in the handle housing.

Reassemble in the reverse sequence.

- Push home the fuel pump (short intake stub facing the air filter) until retaining tabs snap into position.
- Connect suction hose from carburetor to the **short stub** on right.
- Connect hose from connector to **long stub** on left.

The hoses must not be interchanged.

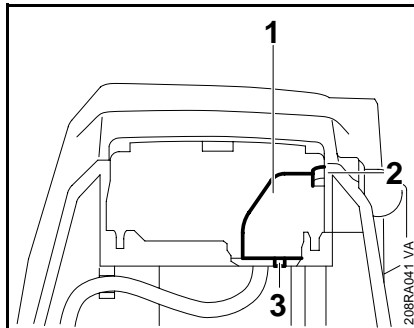

- Push the cover (1) under the upper retaining tab (2) and push the pin (3) into the bore in the handle housing.

The hoses for the tank vent and fuel supply must not be damaged in any way. Replace them if necessary.

- Remove the filter housing –  11.2.2.

Machines without manual fuel pump:

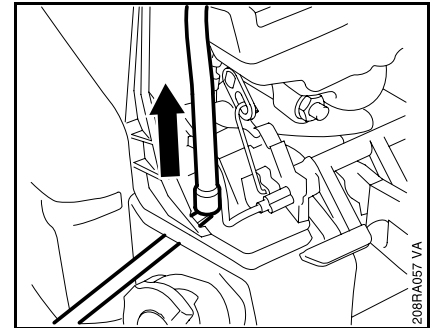

- Remove vent hose from tank.

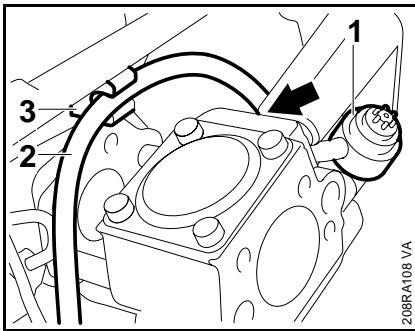

- Detach suction hose (2) from retainer (3) on handle housing.
- Pull suction hose (2) off the stub on the tank vent (1).
- Remove the carburetor –
 11.2.

If hose is damaged, install a new one of the following size:

5.7x3.1x166 mm

Reassemble in the reverse sequence.

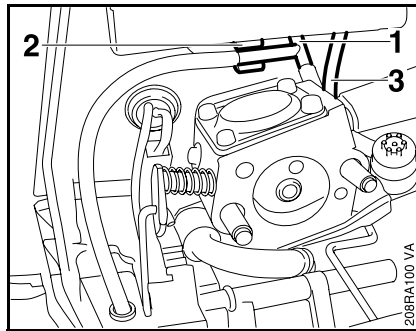

- Pull the connector (1) out of the retainer (2).
- Pull hose (3) off carburetor stub.
- Remove the carburetor –
 11.2.

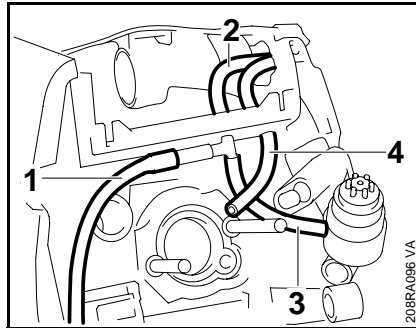

If hoses are damaged, install new ones of the following size:

Hose (1): 5.7x3.1x106 mm

Hose (2): 5.4x2.2x38 mm

Hose (3): 5.7x3.1x51 mm

Hose (4): 5.4x2.2x65 mm

On non-EU version:

Hose (4): 5.4x2.2x100 mm

Reassemble in the reverse sequence.

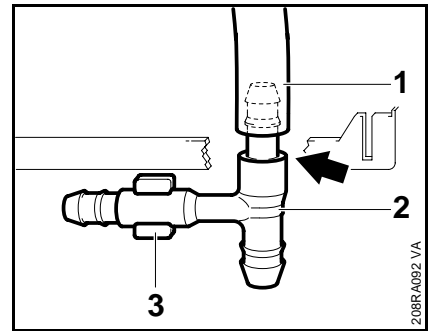

- When assembling, connect the hose (1) to the thin stub (arrow) of the connector (2) and the manual fuel pump to the **long left-hand** stub.
- Push the connector (2) with hose upwards into the handle housing.
- Engage the connector (2) in the retainer (3) on the handle housing.

Reassemble all other parts in the reverse sequence.

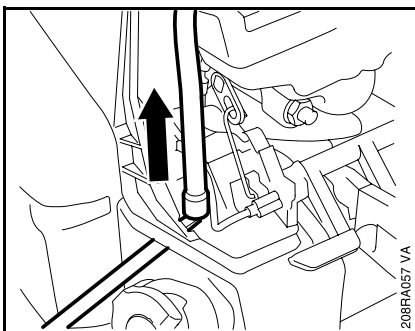

Machines with manual fuel pump:



- Remove the vent hose from the tank.

11.8 Fuel Tank

Fuel tank and engine housing are a single unit.

- Remove the engine –  8.
- Remove the chain tensioner –  8.
- Remove the chain brake –  8.

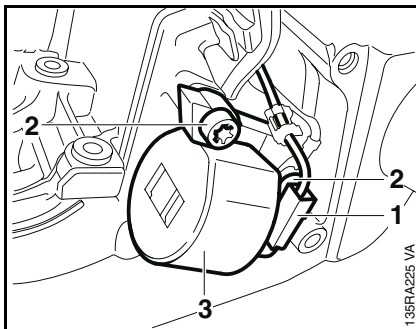

- Disconnect the short circuit wire (1).
- Take out the screws (2).
- Remove the ignition module (3).

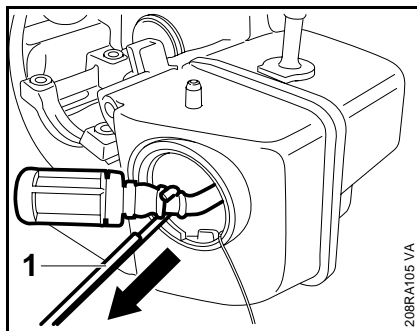

- Unscrew the fuel filler cap and remove with cap retainer, if fitted.
- Use hook (1) 5910 893 8800 to pull pickup body out of the fuel tank.

Do not stretch the suction hose.

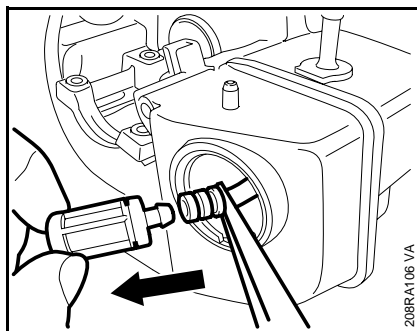

- Pull the pickup body off the hose.

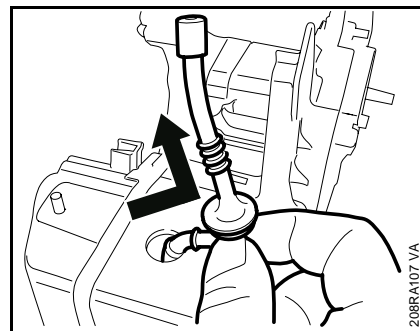

- Pry the suction hose flange out of the fuel tank.

- Pull out the suction hose.

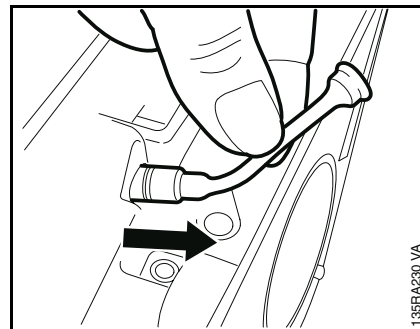

- Pull out the oil pump suction hose with pickup body.

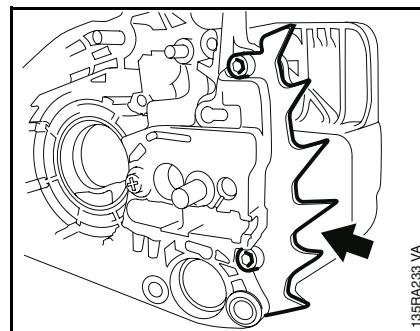

- Remove the spiked bumper, if fitted.

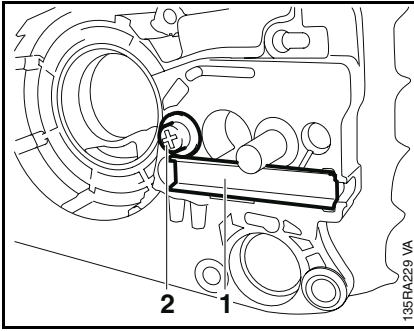

- On machines with quick chain tensioner, remove the stiffener (1) and take out the rear collar screw (2).

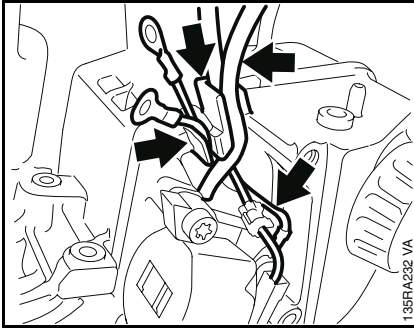

Reassemble in the reverse sequence.

- Position ground wires, short circuit wire and ignition lead in the housing slots.
- After assembling, set air gap between ignition module and flywheel – 8.
- Coat the fuel hose flange with a little oil to simplify installation.
- Straight side of hose flange must be in line with the tank joint.

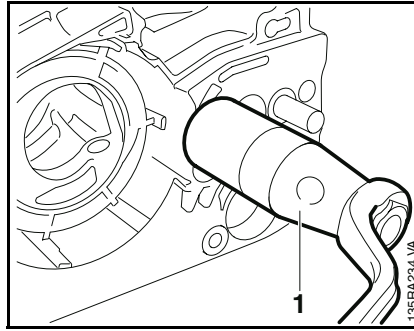

Replacement engine housings are supplied with two collar screws of the same length.

- To install engine housing in a machine with a quick chain tensioner, use stud puller (1) 5910 893 0501 to slowly unscrew the rear collar screw.

Thread in engine housing can be damaged if stud puller is turned too fast.

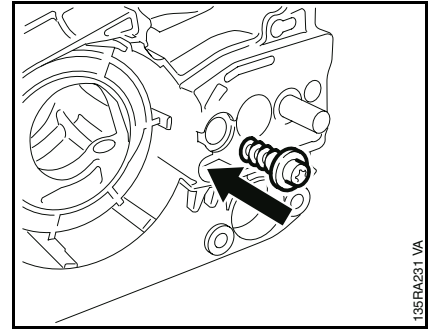

- Apply a little oil to the thread of the new or original collar screw.
- Insert collar screw in the bore of the replacement engine housing and turn it counterclockwise until it engages the thread.
- Then screw it home clockwise and torque down to about 8.0 Nm (5.9 lbf.ft).
- Tighten down mounting screws on spiked bumper to 3.7 Nm (2.8 lbf.ft).

Reassemble all other parts in the reverse sequence.

12. Special Servicing Tools

No.	Part Name	Part No.	Application	Rem.
1	Locking strip	0000 893 5903	Blocking the crankshaft	
2	Press sleeve	1123 893 2400	Installing oil seal(s)	
3	Guide sleeve	1123 894 7700	Protects oil seal at starter side	
4	Puller	5910 890 4400	Removing oil seals	1)
5	Jaws (No. 6 profile)	0000 893 3711	Removing oil seals	
6	Puller	1116 893 0800	Removing flywheel	
7	Crimping tool	5910 890 8210	Attaching connectors to electrical wires	
8	Assembly drift	1110 893 4700	Removing and fitting piston pin	
9	Carburetor and crankcase tester	1106 850 2905	Testing engine and carburetor for leaks	
10	Nipple	0000 855 9200	Testing carburetor for leaks	
11	Fuel hose	1110 141 8600	Testing carburetor for leaks	
12	Vacuum pump	0000 850 3501	Testing engine for leaks	
13	Sealing plate	0000 855 8106	Sealing exhaust port for leakage test	
14	Flange	1123 855 4200		
15	Sleeve (4)	1123 851 8300		
16	Flange	1118 850 4200	Leakage test	
17	Setting gauge	1111 890 6400	Setting air gap between ignition module and flywheel	
18	Socket, DIN 3124, 13 mm	5910 893 5608	Flywheel nut	
19	Socket, DIN 3124, 19 mm x12.5L	5910 893 5612	Clutch	
20	Torque wrench	5910 890 0301	0.5 – 18 Nm (0.4 – 13.5 lbf.ft) Alternative: Torque wrench 5910 890 0302 with optical/acoustic signal	
21	Torque wrench	5910 890 0311	6 – 80 Nm (4.4 – 60 lbf.ft) Alternative: Torque wrench 5910 890 0312 with optical/acoustic signal	
22	Spline screw socket T 27 x 150	0812 542 2104	IS-P screws (4 mm)	

Remarks:

1) Equivalent to puller 0000 890 4400, but with longer spindle 5910 890 8400.

No.	Part Name	Part No.	Application	Rem.
23	Hook	5910 893 8800	Removing pickup body	
24	Installing tool 10	5910 890 2210	Installing hookless snap rings in piston	
25	Assembly tube	1117 890 0900	Attaching/detaching brake spring	
26	Spline socket screwdriver T 27 x 150	5910 890 2400	IS screws	2)
27	Stud puller M 8	5910 893 0501	Removing guide bar mounting studs	
28	Installing tool	1123 890 2201	Removing/installing oil pump	
29	Installing tool	1116 893 4800	Refitting rewind spring	
30	Assembly stand	5910 890 3100	Holds chainsaw for repairs	
31	Clamping bar	5910 890 2000	For mounting chainsaw to assembly stand	
32	Jaws (No. 3.1 + 4 profile)	0000 893 3706	Removing oil seal(s)	
33	Sleeve	1124 893 7100		

Remarks:

2) Only use for releasing DG screws.

13. Servicing Aids

No.	Part Name	Part No.	Application
1	Lubricating grease (370 g / 13 oz tube)	0781 120 1111	Oil seals, oil pump drive, chain sprocket bearing, chain tensioner, cylindrical rollers
2	Press-Fluid lubricant	0781 957 9000	Rubber buffers of AV system
3	STIHL special lubricant	0781 417 1315	Bearing bore in rope rotor, rewind spring in fan housing
4	Dirko sealant (100 g / 3 1/2 oz tube)	0783 830 2120	Engine pan, oil seals (outside)
5	STIHL cleaner		Crankshaft stubs and taper on flywheel
6	STIHL Bioplus (1 ltr./ 34 fl.oz bottle)	0781 516 3331	Protects brake band from corrosion
7	Molybdenum grease (Molykote)		Sliding and bearing points of brake band
8	Graphite grease		Peg on pawl
9	Hose, 5.4x2.2x1000 mm	0000 930 2800	Fuel/suction hose
10	Hose, 5.7x3.1x1000 mm	0000 930 2801	Fuel/suction hose

englisch / english

0455 208 0123. M0,5. A7. Rei. Printed in Germany