



**RED LION®**

# PRODUCT CATALOG

CLEANWATER • LAWN & IRRIGATION • SUMP • EFFLUENT/SEWAGE • MULTI-PURPOSE • ENGINE DRIVE



Technical Service Line: 888.885.9254

[redlionproducts.com](http://redlionproducts.com)



# RED LION®

## ABOUT US

---

Backed by the heritage of a global leader in the development and manufacturing of systems and components that move water, the Red Lion® brand remains at the forefront of product innovation by listening to its customers, adapting to the market, and continuing to invest in research and development. This innovative product portfolio is supported by unparalleled service to provide you with current solutions to your water pumping challenges.

---



# TABLE OF CONTENTS

Index by item and model number is located at the end of the catalog.

## 2 CLEANWATER

- 2 Premium Shallow Well Jet Pumps
- 3 Cast Iron Shallow Well Jet Pumps
- 4 Stainless Steel Shallow Well Jet Pumps
- 5 Premium Cast Iron Convertible Jet Pumps
- 6 High Performance Cast Iron Convertible Jet Pump
- 7 Pre-Charged Pressure Tanks
- 8 Pump & Tank Systems
- 9 4" Submersible Well Pumps
- 11 1-2-3 Easy Guide for Pump & Tank Selection
- 12 Typical Installations

## 13 LAWN & IRRIGATION

- 13 Cast Iron Sprinkler Utility Pump
- 14 Stainless Steel Sprinkler Utility Pump
- 15 Sprinkler Pump
- 16 Cast Iron Industrial Sprinkler Pump

## 17 SUMP

- 17 Thermoplastic Sump Pumps
- 18 Stainless Steel Sump Pumps
- 19 Cast Iron Sump Pumps
- 20 1/3 HP Dual Cast Iron Sump Pump System
- 21 Snap-Action Cast Iron Sump/Effluent Pumps
- 22 Premium Submersible Stainless Steel Sump Pumps
- 23 Pedestal Pumps
- 24 Under-Sink Sump Package
- 25 Battery Backup System

## 26 EFFLUENT/SEWAGE

- 26 Cast Iron Surface Effluent Pump
- 27 Snap-Action Cast Iron Sump/Effluent Pumps
- 28 Premium Submersible Stainless Steel Sump/Effluent Pumps
- 29 Sewage Pump
- 30 Heavy-Duty Cast Iron Effluent Pump
- 31 Cast Iron Sewage Pump
- 32 Premium Cast Iron Sewage Pump
- 33 Sewage Basin Systems

## 34 MULTI-PURPOSE

- 34 Thermoplastic Utility Pumps
- 35 Aluminum Utility Pumps
- 36 Automatic Utility Pump
- 37 Utility Transfer Pumps
- 38 Camo Multi-Purpose Pump
- 39 Multi-Purpose Transfer Pump
- 40 Drill Powered Transfer Pump
- 41 Condensate Removal Pumps
- 42 Heavy-Duty Submersible Utility Pump

## 43 ENGINE DRIVE

- 43 Aluminum Water Transfer Pump | 2RLAG-1L
- 44 Aluminum Water Transfer Pump | 4RLAG-2H
- 45 Aluminum Water Transfer Pump | 5RLAG-2L
- 46 Aluminum Water Transfer Pump Kit | 5RLAG-2LKIT
- 47 Engine Drive Cast Iron Transfer Pump | 5RLGF-8KRF
- 48 Thermoplastic AG Chemical & Transfer Pump | 6RLPG-2U
- 49 Thermoplastic AG Chemical & Transfer Pump | 6RLPG-2K
- 50 Aluminum Semi-Trash Pumps | 6RLAG-2LST & 6RLAG-3LST
- 51 Engine Drive Semi-Trash Pump | 6RLAG-3HST
- 52 Aluminum Trash Pump | 6RLAG-3LTT

## 53 RESOURCES

- 53 Accessories
- 54 Training Program
- 55 Troubleshooting Guide
- 62 Glossary Of Terms
- 65 Technical Data
- 66 Index Of Items Numerically By Item Number
- 68 Index Of Items Alphabetically By Model

*Every effort has been made to ensure the accuracy of the information provided in this catalog. Red Lion reserves the right to change any information contained in this catalog without notice. Stenographic and clerical errors are subject to corrections.*



**RED LION**

# PREMIUM SHALLOW WELL JET PUMPS

## APPLICATIONS

Ideal for the supply of fresh water to rural homes, farms, and cabins that have suction lifts down to 25'.

## FEATURES & BENEFITS

- High performance shallow well jet pump able to handle the water demands of large homes, cottages, and farms
- Rugged cast iron casing for years of service and reliability
- Heavy-duty dual voltage (115/230 Volt) motor with capacitor for increased starting power
- Includes factory pre-set 30/50 pressure switch that produces up to 50 psi with automatic shut-off
- Glass-filled thermoplastic impeller and diffuser for superior performance and efficient water flow



Model	Item No.	UPC	HP	Volts	Amps	Intake	Discharge	Suction Lift	Discharge Pressure (PSI)				Max. Pressure (PSI)	Max. Head
									30	40	50	60		
RJS-50-PREM	602206	0 10121 14702 7	1/2	115/230	11.8 A @ 115 V 5.9 A @ 230 V	1-1/4" FNPT	1" FNPT	5'	12.6	10	6.1	2	65	150'
								15'	10	7.9	4	-	60	139'
								25'	6.9	6.2	2.5	-	55	127'
RJS-75-PREM	602207	0 10121 14704 1	3/4	115/230	14.4 A @ 115 V 7.2 A @ 230 V	1-1/4" FNPT	1" FNPT	5'	16.7	12.5	7	1.8	65	150'
								15'	13.1	10	4.9	-	60	139'
								25'	8.4	7.1	2.1	-	55	127'
RJS-100-PREM	602208	0 10121 14705 8	1	115/230	17.6 A @ 115 V 8.8 A @ 230 V	1-1/4" FNPT	1" FNPT	5'	23.2	16.8	10.6	3.5	65	150'
								15'	19.5	14.1	7.7	-	60	139'
								25'	13.3	11.5	5.3	-	55	127'

## CARTON SPECIFICATIONS

Model	Length	Width	Height	Weight (lbs)	Carton Cubes (cu ft)	Pallet Quantity	Quantity per Layer	Layers per Pallet
RJS-50-PREM	10.5"	20.5"	10.25"	38	1.28	24	6	4
RJS-75-PREM	10.5"	20.5"	10.25"	39	1.28	24	6	4
RJS-100-PREM	10.5"	20.5"	10.25"	40	1.28	24	6	4

Premium Cast Iron Shallow Well Jet Pumps

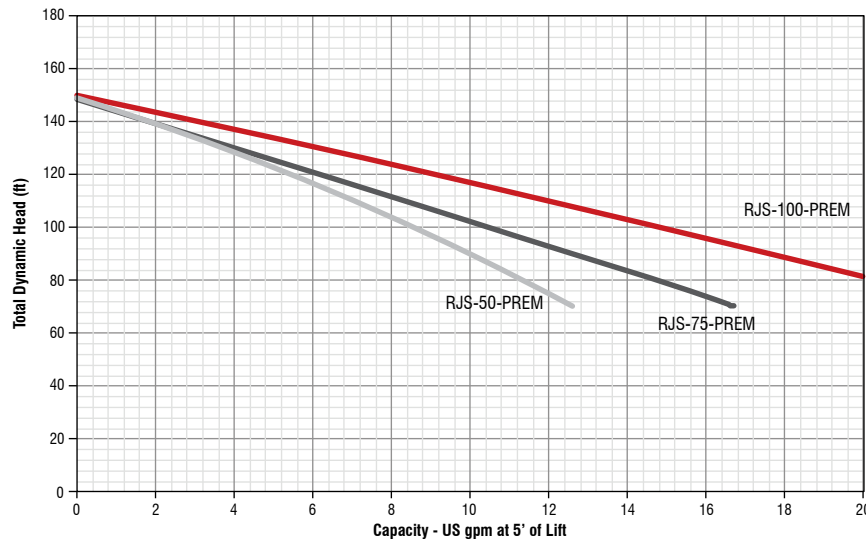

# CAST IRON SHALLOW WELL JET PUMPS

## APPLICATIONS

Ideal for the supply of fresh water to rural homes, farms, and cabins that have suction lifts down to 25'.

## FEATURES & BENEFITS

- Shallow well jet pump ideal for use in shallow wells less than 25' deep
- Heavy-duty cast iron construction for years of service and reliability
- Includes factory pre-set 30/50 pressure switch that produces up to 50 psi with automatic shut-off
- 115/230 Volt heavy-duty motor; TEFC design with simple connection to existing power source



Model	Item No.	UPC	HP	Volts	Amps	Intake	Discharge	Suction Lift	Discharge Pressure (PSI)					Max. Pressure (PSI)	Max. Head
									20	30	40	50	60		
RL-SWJ50	97080502	0 10121 14671 6	1/2	115/230	8.4 A @ 115 V 4.2 A @ 230 V	1-1/4" FNPT	1" FNPT	5'	13.6	12.6	7.3	3.4	1	64	148'
								15'	9.7	9.5	5.5	2.8	0.3	60	139'
								25'	4.7	5	4.1	1.7	-	57	133'
RL-SWJ75	97080701	0 10121 14672 3	3/4	115/230	9 A @ 115 V 4.5 A @ 230 V	1-1/4" FNPT	1" FNPT	5'	13.4	13	9.1	4.8	1.5	70	161'
								15'	9.8	9.7	7.2	3.4	0.8	66	152'
								25'	4.4	5.2	4.8	1.8	0.4	62	144'
RL-SWJ100	97081001	0 10121 14673 0	1	115/230	13.2 A @ 115 V 6.6 A @ 230 V	1-1/4" FNPT	1" FNPT	5'	17.3	17	12.9	8.5	4.4	74	172'
								15'	12.7	12.4	10.9	7	2.7	72	166'
								25'	6.7	6.5	6.6	5.2	2	68	156'

## CARTON SPECIFICATIONS

Model	Length	Width	Height	Weight (lbs)	Carton Cubes	Pallet Quantity	Quantity per Layer	Layers per Pallet
RL-SWJ50	12"	17.25"	11.75"	23	1.41	32	8	4
RL-SWJ75	12"	17.25"	11.75"	24.55	1.41	32	8	4
RL-SWJ100	12"	17.25"	11.75"	30.55	1.41	32	8	4

Cast Iron Shallow Well Jet Pumps

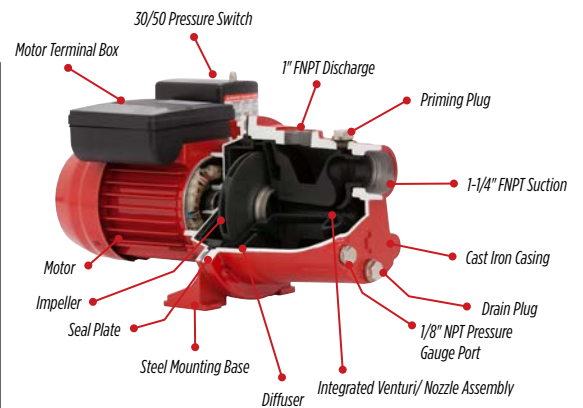
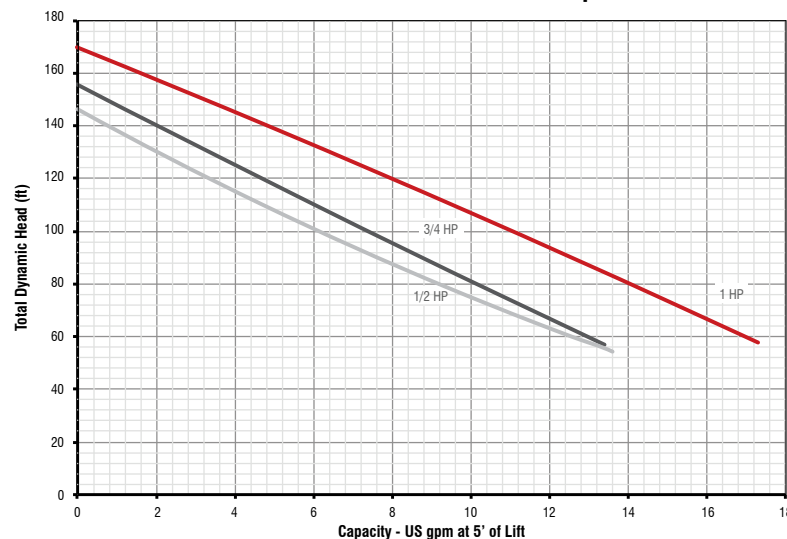

# STAINLESS STEEL SHALLOW WELL JET PUMPS

## APPLICATIONS

Ideal for supply of fresh water to rural homes, farms, and cabins that have suction lifts down to 25'.

## FEATURES & BENEFITS

- Shallow well stainless steel jet pump is ideal for use in pumping at depths of 25' or less
- Corrosion-resistant stainless steel pump housing suitable for aggressive water conditions
- Includes factory pre-set 30/50 pressure switch that produces up to 50 psi with automatic shut-off
- 115/230 Volt heavy-duty motor; TEFC design with simple connection to existing power source



Model	Item No.	UPC	HP	Volts	Amps	Intake/Discharge	Pressure Gauge Port	Suction Lift	Discharge Pressure (PSI)				Max. Pressure (PSI)	Max. Head
									30	40	50	60		
RJS-75SS	97080702	0 10121 14939 7	3/4	115/230	9.0 A @ 115 V 4.5 A @ 230 V	1" FNPT	1/8" NPT	5'	12.8	9.1	5.3	2.1	73	169'
								15'	9.4	7.4	3.9	1.7	68	158'
								25'	4.9	4.9	2.7	0.2	65	150'

## CARTON SPECIFICATIONS

Model	Length (in)	Width (in)	Height (in)	Weight (lbs)	Carton Cubes (cu ft)	Pallet Quantity	Quantity per Layer	Layers per Pallet
RJS-75SS	12.25"	17.5"	11.75"	18.5	1.46	24	6	4

Stainless Steel Shallow Well Jet Pump

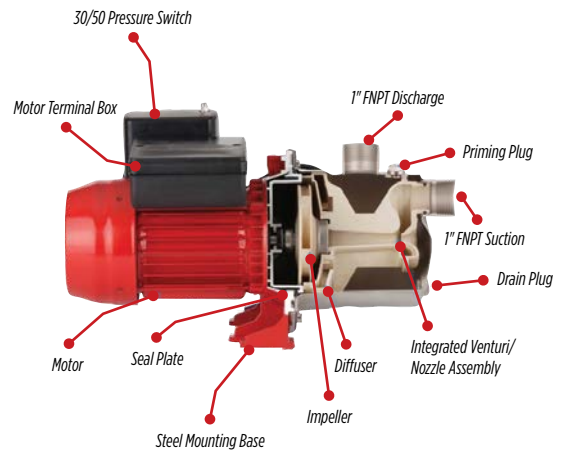
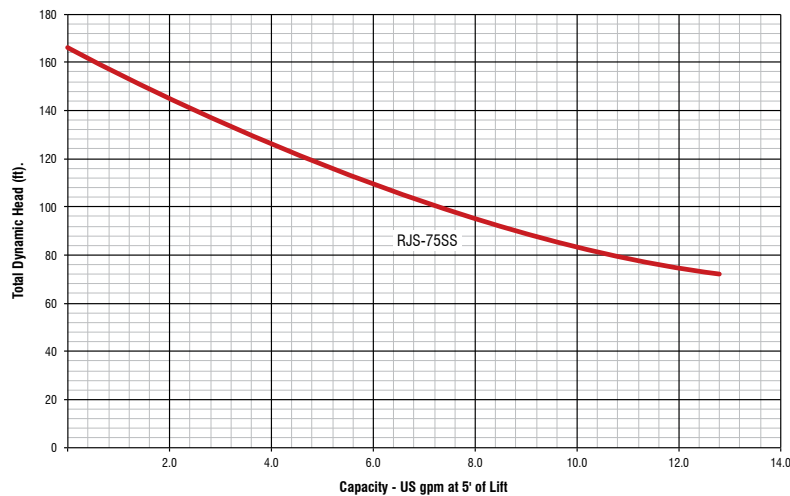

# PREMIUM CAST IRON CONVERTIBLE JET PUMPS

## APPLICATIONS

Ideal for the supply of fresh water to rural homes, farms, and cabins that have suction lifts down to 90'.

## FEATURES & BENEFITS

- Convertible jet pump with deep well injector is ideal for use in shallow well (less than 25') and deep well (25' to 90') applications
- Rugged cast iron casing for years of service and reliability
- Premium, heavy-duty, dual voltage (115/230 Volts) motor features copper windings to ensure high efficiency and dependable motor life
- Includes factory pre-set 30/50 pressure switch that produces up to 50 psi with automatic shut-off
- Glass-filled thermoplastic impeller and diffuser for high performance and efficient water flow



Model	Item No.	UPC	HP	Volts	Amps	Intake	Discharge	No. of Pipes	Suction Lift	Discharge Pressure (PSI)				Max. Press. (PSI)	Max. Head	Max. Flow (GPM)			
										30	40	50	60						
RJC-50-PREM	602136	0 10121 15110 9	1/2	115/230	14.4 A @ 115 V 7.2 A @ 230 V	1-1/4" FNPT	1" FNPT	1	5'	14.2	10.2	5.9	1.8	64	149'	14.2			
									15'	13.5	9.1	4.4	-				60	139'	
									2	25'	9.6	7.4	2.4				-	56	129'
									2	30'	5.8	3.7	1.8				0.2	62	143'
									2	60'	4.3	2.7	1.4				0.3	63	146'
									2	90'	1.6	0.7	0.1				-	51	119'
									1	5'	16.2	12.2	8				3.7	68	158'
									1	15'	14.3	10.6	6.1				1.3	64	147'
									2	25'	9.8	8.9	4.7				-	61	141'
									2	30'	7.2	4.8	2.8				1.2	69	159'
2	60'	5.4	3.7	2.2	1.1	73	169'												
2	90'	2.2	1.3	0.4	-	58	133'												
RJC-75-PREM	602137	0 10121 15111 6	3/4	115/230	17.6 A @ 115 V 8.8 A @ 230 V	1-1/4" FNPT	1" FNPT	2	25'	9.8	8.9	4.7	-	61	141'	16.2			
									30'	7.2	4.8	2.8	1.2	69	159'				
									60'	5.4	3.7	2.2	1.1	73	169'				
									90'	2.2	1.3	0.4	-	58	133'				

## CARTON SPECIFICATIONS

Model	Length	Width	Height	Weight (lbs)	Carton Cubes (cu ft)	Pallet Quantity	Quantity per Layer	Layers per Pallet
RJC-50-PREM	10.5"	20"	10.5"	43.8	1.28	32	8	4
RJC-75-PREM	10.5"	20"	10.75"	45.7	1.31	32	8	4



Pressure Gauge and Injector Kit Included

# HIGH PERFORMANCE CAST IRON CONVERTIBLE JET PUMP

## APPLICATIONS

Ideal for the supply of fresh water to rural homes, farms, and cabins that have suction lifts down to 90'.

## FEATURES & BENEFITS

- Convertible jet pump with deep well injector is ideal for use in shallow well (less than 25') and deep well (25' to 90') applications
- Rugged cast iron casing is ideal for supplying fresh water to rural homes, farms, and cabins
- Heavy-duty motor, 115/230 Volts for years of service and reliability
- Includes factory pre-set 30/50 pressure switch that produces up to 50 psi with automatic shut-off
- Glass-filled thermoplastic impeller and diffuser for high performance and efficient water flow

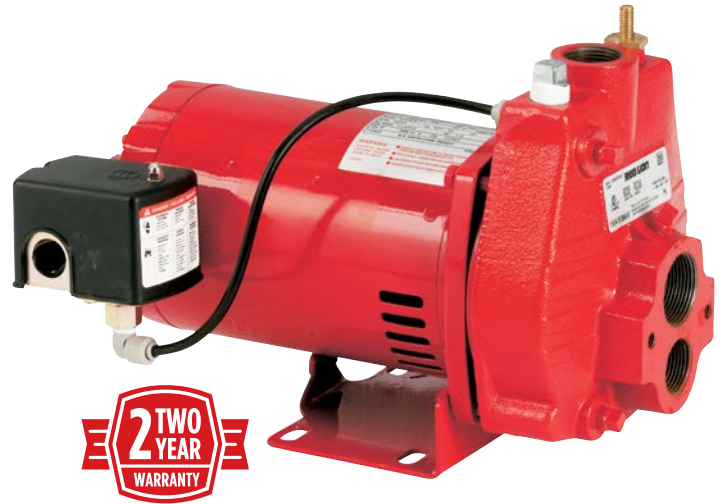

Model	Item No.	UPC	HP	Volts	Amps	Intake	Discharge	No. of Pipes	Suction Lift	Discharge Pressure (PSI)					Max. Pressure PSI	Max. Head	Max. Flow GPM
										20	30	40	50	60			
RJC-100	602038	0 10121 12284 0	1	115/230	16.4 A @ 115 V 8.2 A @ 230 V	1-1/4"	1" FNPT	1	5'	20.0	19.9	16.7	11.1	5.6	71.0	164'	20
								1	15'	14.5	14.1	13.6	8.7	3.3	66.7	154'	
								2	20'	-	10.5	7.3	5.2	3.6	87.0	201'	
								2	50'	-	7.2	5.0	3.4	1.9	74.0	171'	
								2	90'	-	3.4	1.9	0.7	-	56.7	131'	

## CARTON SPECIFICATIONS

Model	Length	Width	Height	Weight (lbs)	Carton Cubes (cu ft)	Pallet Quantity	Quantity per Layer	Layers per Pallet
RJC-100	10.33"	20.25"	11.5"	38	1.39	32	8	4



Injector Kit Included

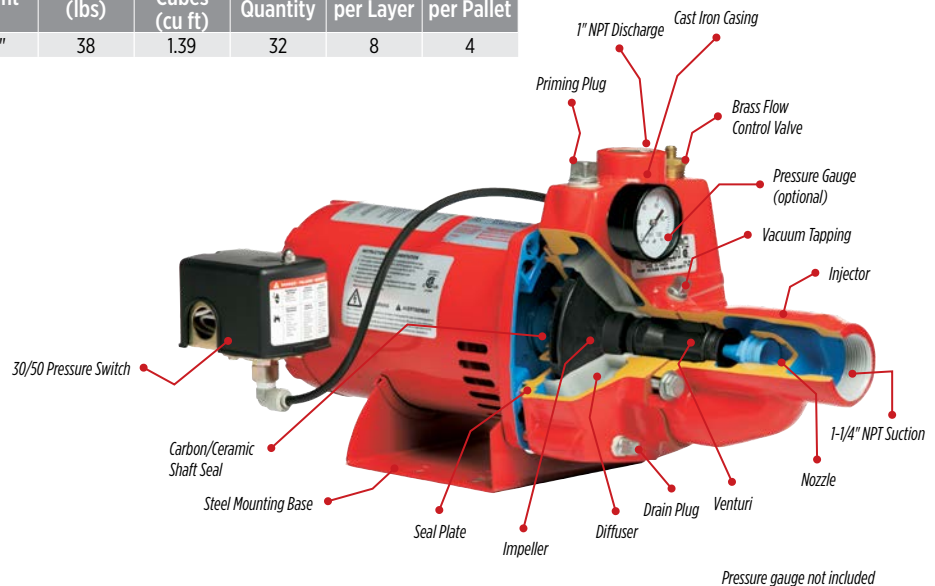

# PRE-CHARGED PRESSURE TANKS

## APPLICATIONS

For maintaining the water pressure in a residential water pump system when the pump is not running.

## FEATURES & BENEFITS

- ANSI/NSF Standard 61 approved assures safe, clean drinking water
- Blended butyl rubber diaphragm system isolates the air charge from the water chamber; reinforced in specific wear areas for longer life
- Heavy-duty, cold-rolled steel construction
- Leak-resistant, O-ring sealed air valve cap allows adjustment of air pre-charge
- Unique, patented dual water/air seal design offers superior leak protection
- Durable two-part paint finish is suitable for outdoor use and provides hundreds of hours of UV and salt spray protection in moderate climates\*



Model	Item No.	UPC	Gallons	Drawdown @ 30/50 psi (gal)	Fixtures	Type	System Connect
RL2	604452	0 10121 12335 9	2.1	0.7	-	Inline	3/4" MNPT
RL4	604453	0 10121 12336 6	4.8	1.5	-	Inline	3/4" MNPT
RL8	604454	0 10121 12337 3	8.5	2.6	-	Inline	3/4" MNPT
RL6H	604529	0 10121 12126 3	5.3	1.6	1	Horizontal	3/4" MNPT
RL14H	604493	0 10121 12124 9	14.0	4.3	4	Horizontal	3/4" MNPT
RL16*	604587	0 10121 15197 0	15.9	4.9	5	Vertical	1" NPT
RL20H*	604581	0 10121 15158 1	21.1	6.2	7	Horizontal	1" NPT
RL21*	604582	0 10121 15159 8	21.1	6.5	7	Vertical	1" NPT
RL34*	604583	0 10121 15160 4	34.3	10.6	11	Vertical	1" NPT
RL40*	604584	0 10121 15161 1	40.0	12.4	13	Vertical	1" NPT
RL81	604541	0 10121 12365 6	81.0	27.6	27	Vertical	1-1/4" NPT
RL119	604531	0 10121 12360 1	119.0	40.6	39	Vertical	1-1/4" NPT

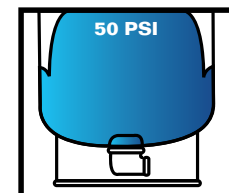
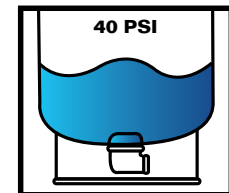
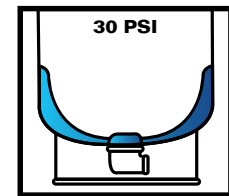

## CARTON SPECIFICATIONS

Model	Length	Width	Height	Weight (lbs)	Carton Cubes (cu ft)	Pallet Quantity	Quantity per Layer	Layers per Pallet
RL2	8.33"	8.33"	12.75"	5.0	0.51	60	20	3
RL4	11.12"	11.12"	15"	10.0	1.07	36	12	3
RL8	13.5"	19.5"	13.5"	15.4	2.06	18	6	3
RL6H	10.5"	18"	12.25"	13.3	1.34	18	6	3
RL14H	15.75"	21.25"	17.25"	27.0	3.34	8	4	2
RL16	15.5"	15.75"	25.13"	24.9	3.55	6	6	1
RL20H	15.75"	29"	17.25"	35.8	4.56	6	3	2
RL21	15.75"	15.5"	32.75"	35.8	4.63	6	6	1
RL34	17.25"	17.5"	43.25"	58.8	7.56	4	4	1
RL40	21.5"	21.25"	37.25"	76.3	9.85	2	2	1
RL81	21.5"	21.5"	60"	101.0	16.05	2	2	1
RL119	26.75"	26.75"	61.5"	160.0	25.47	1	1	1

# PUMP & TANK SYSTEMS

## APPLICATIONS

Ideal for the supply of fresh water to rural homes, farms, and cabins where compact system size and ease of installation are most important.

## FEATURES & BENEFITS

- Jet pump and pre-charged pressure tank are factory assembled and ready to install
- Pump casing is made of rugged cast iron
- Pre-charged steel tank has a high grade diaphragm water chamber (5.3-14 gallons)
- Low profile, compact horizontal pressure tank
- Includes factory pre-set 30/50 pressure switch
- Can be set for use with 115 Volts or 230 Volts



RL-SWJ50/RL6H

RJS-50/RL14H

Model	Item No.	UPC	HP	Gal.	Volts	Amps	Intake	Discharge	Press. Gauge Port	Suc. Lift	No. of Pipes	Discharge Pressure (PSI)				Max. Press. (PSI)	Max. Head	
												20	30	40	50			60
RL-SWJ50/RL6H	97080503	0 10121 14942 7	1/2	5.8	115/230	8.4 A @ 115 V 4.2 A @ 230 V	1-1/4" FNPT	1" FNPT	1/8" NPT	5'	1	13.6	12.6	7.3	3.4	1	64	148'
										15'	1	9.7	9.5	5.5	2.8	0.3	60	139'
										25'	1	4.7	5	4.1	1.7	0	57	133'
RJS-50/RL6H	602099	0 10121 12241 3	1/2	5.3	115/230	11.2 A @ 115 V 5.6 A @ 230 V	1-1/4" FNPT	1" FNPT	1/4" NPT	5'	1	12.8	12.3	11.2	6.9	2	64.2	148'
										15'	1	9.8	9.6	9.4	4.7	-	59.9	138'
										25'	1	5.6	5.5	5.3	2.3	-	55.5	128'
RJS-50/RL14H	602014	0 10121 12230 7	1/2	14	115/230	11.2 A @ 115 V 5.6 A @ 230 V	1-1/4" FNPT	1" FNPT	1/4" NPT	5'	1	12.8	12.3	11.2	6.9	2	64.2	148'
										15'	1	9.8	9.6	9.4	4.7	-	59.9	138'
										25'	1	5.6	5.5	5.3	2.3	-	55.5	128'
RJC-50/RL6H	602102	0 10121 12240 6	1/2	5.3	115/230	11.2 A @ 115 V 5.6 A @ 230 V	1-1/4" FNPT	1" FNPT	1/4" NPT	5'	1	11.1	10.9	10.7	7.4	4.5	76.2	176'
										15'	1	8.1	7.9	7.7	5.9	3.1	71.7	165'
										20'	2	-	9.2	6.5	4.5	2.9	85	196'
										50'	2	-	5.8	4	2.4	1.3	72	166'
										80'	2	-	3.4	2.2	1	-	59	136'

## CARTON SPECIFICATIONS

Model	Length	Width	Height	Weight (lbs)	Carton Cubes (cu ft)	Pallet Quantity	Quantity per Layer	Layers per Pallet
RL-SWJ50 / RL6H	22.85"	14.5"	25.25"	38.4	4.84	4	4	1
RJS-50 / RL6H	24.6"	14"	26"	53	5.18	4	4	1
RJS-50 / RL14H	23.5"	17"	32"	67	7.40	4	4	1
RJC-50 / RL6H	24.6"	12.6"	27"	54	4.84	4	4	1

## ADDITIONAL FEATURES

Model	Includes
RL-SWJ50 / RL6H	Pressure gauge
RJS-50 / RL6H	Pressure gauge, foot valve
RJS-50 / RL14H	Pressure gauge, foot valve
RJC-50 / RL6H	Injector, pressure gauge, foot valve

# 4" SUBMERSIBLE WELL PUMPS

## APPLICATIONS

Ideal for the supply of fresh water to rural homes, farms, and cabins that have 4" and greater diameter drilled wells to depths of 250'.

## FEATURES & BENEFITS

- Powered by industry standard 2- or 3-wire motors
- Thermoplastic discharge and motor bracket
- Stainless steel pump shell
- Built-in suction screen and check valve
- 12 gpm and 22 gpm models available
- Control box included with all 3-wire pumps (1/2-1 hp)



4" Submersible Well Pumps

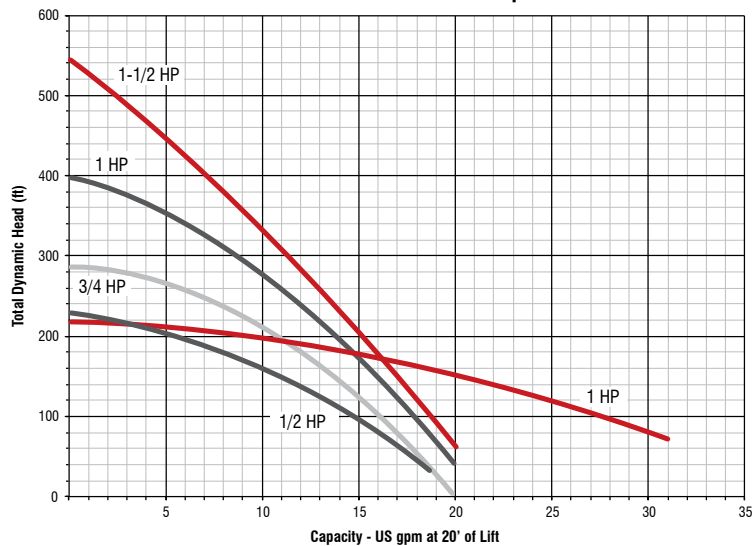

## CARTON SPECIFICATIONS

Model	Item No.	Length	Width	Height	Weight (lbs)	Carton Cubes (cu ft)	Pallet Quantity	Quantity per Layer	Layers per Pallet
Pumps only									
RL12G05-2W1V	14942401	4.6"	4.6"	28.5"	21	.35	100	10	10
RL12G05-2W2V	14942402	4.6"	4.6"	29"	21	.36	100	10	10
RL12G07-2W2V	14942403	4.6"	4.6"	29"	24	.36	100	10	10
RL12G10-2W2V	14942404	4.6"	4.75"	29"	28	.37	100	10	10
RL12G05-3W2V	14942405	4.6"	5.75"	38.25"	25	.59	80	8	10
RL12G07-3W2V	14942406	4.6"	5.75"	38.25"	28	.59	80	8	10
RL12G10-3W2V	14942407	4.75"	6"	43.75"	32	.72	60	6	10
RL12G15-3W2V	14942408	4.6"	4.6"	39.25"	36	.48	100	10	10
RL22G10-3W2V	14942409	4.6"	5.75"	43.75"	31	.67	70	7	10

Nomenclature: RL = Red Lion, 12G = 12 Gallon, ## = HP (05 = 1/2, 07 = 3/4, 10 = 1, 15 = 1.5), # W = Number of Wires, # V = Voltage (1 = 115, 2 = 230), SP = Sub-Pac  
 Example: RL12G05-2W1V = 12 Gallon, 1/2 hp, 2-wire, 115 Volt

# 4" SUBMERSIBLE WELL PUMPS

Model	Item No.	UPC	HP	Wires	Volts	Amps	Depth to Water	Discharge Pressure (PSI)								Discharge	Shut-Off	Max. Flow (GPM)	Avail.	
								0	10	20	30	40	50	60	70					80
								Gallons Per Minute												
RL12G05-2W1V	14942401	0 10121 14177 3	1/2	2	115	12	20'	-	19	18	16	15	14	12	10	6	1-1/4" FNPT	231'	12	Canada only
							40'	19	18	16	15	14	13	11	7	2				
							60'	18	17	16	14	13	11	7	3	-				
							80'	17	16	15	13	11	8	3	-	-				
							100'	16	15	13	11	8	4	-	-	-				
							140'	14	12	9	5	-	-	-	-	-				
							200'	7	2	-	-	-	-	-	-	-				
RL12G05-2W2V RL12G05-3W2V*	14942402 14942405	0 10121 14178 0 0 10121 14181 0	1/2	2 3	230	6	20'	-	19	18	16	15	14	12	10	6	1-1/4" FNPT	231'	12	Canada only
							40'	19	18	16	15	14	13	11	7	2				
							60'	18	17	16	14	13	11	7	3	-				
							80'	17	16	15	13	11	8	3	-	-				
							100'	16	15	13	11	8	4	-	-	-				
							140'	14	12	9	5	-	-	-	-	-				
							200'	7	2	-	-	-	-	-	-	-				
RL12G07-2W2V RL12G07-3W2V*	14942403 14942406	0 10121 14179 7 0 10121 14182 7	3/4	2 3	230	8	20'	-	20	18	17	16	15	14	12	-	1-1/4" FNPT	291'	12	Canada only
							40'	20	19	17	17	16	15	14	13	11				
							60'	19	18	17	16	15	14	13	11	9				
							80'	18	17	16	15	14	13	11	9	6				
							100'	17	16	15	14	13	12	9	6	3				
							140'	15	15	14	13	10	7	4	-	-				
							200'	13	11	8	5	1	-	-	-	-				
RL12G10-2W2V RL12G10-3W2V*	14942404 14942407	0 10121 14180 3 0 10121 14183 4	1	2 3	230	10.4	20'	-	20	19	18	17	16	15	14	-	1-1/4" FNPT	399'	12	
							40'	-	20	19	18	17	16	15	14					
							60'	20	19	18	17	17	16	15	14	13				
							80'	19	18	17	17	16	15	14	13	12				
							100'	18	17	17	16	15	14	13	12	11				
							140'	17	16	16	15	14	13	12	10	8				
							200'	15	14	13	11	11	9	7	5	2				
RL12G15-3W2V	14942408	0 10121 14184 1	1-1/2	3	230	11.5	20'	-	20	19	18	17	17	16	15	-	1-1/4" FNPT	545'	12	
							40'	-	20	19	18	18	17	17	16	16				
							60'	-	20	19	18	18	17	17	16	16				
							80'	20	19	18	18	17	17	16	16	15				
							100'	19	18	18	17	17	16	16	15	15				
							140'	18	17	17	16	16	15	15	14	14				
							200'	17	16	16	15	15	14	13	13	12				
RL22G10-3W2V*	14942409	0 10121 14185 8	1	3	230	10.4	20'	-	31	28	26	23	19	11	-	1-1/4" FNPT	221'	22		
							40'	-	32	28	26	24	20	12	1					
							60'	-	33	29	26	24	20	14	3					-
							80'	-	29	27	24	21	15	4	-					-
							100'	30	27	25	22	16	6	-	-					-
							140'	25	23	18	9	-	-	-	-					-
							200'	13	2	-	-	-	-	-	-					-

NOTE: SP indicates Sub-Pac, which includes factory spliced power cable, control center, pressure switch and gauge, pressure relief valve, and tank cross  
\*Includes control box

## CONTROL BOXES FOR 4" SUBMERSIBLE WELL PUMPS

Model	Item No.	UPC	HP	Volts	Length	Width	Height	Wt. (lbs)	Carton Cubes (cu ft)	Master Pack Qty.	Pallet Quantity	Quantity per Layer	Layers per Pallet
RLCB05-115	640188	0 10121 12203 1	1/2	115	8.75"	5.25"	3.25"	3	.09	10	45 Master Packs	9 Master Packs	5
RLCB05-230	640189	0 10121 12204 8	1/2	230	8.75"	5.35"	3.25"	3	.09	10	45 Master Packs	9 Master Packs	5
RLCB07-230	640190	0 10121 13096 8	3/4	230	9.0"	5.25"	3.0"	3	.08	10	45 Master Packs	9 Master Packs	5
RLCB10-230	640191	0 10121 13097 5	1	230	9.0"	5.5"	3.5"	3	.10	10	45 Master Packs	9 Master Packs	5
RLCB15-230	640222	0 10121 13173 6	1-1/2	230	11.5"	8.25"	6.25"	6	.34	10	45 Master Packs	9 Master Packs	5

NOTE: For cable size information, see the technical data section



# 1-2-3 EASY GUIDE FOR PUMP & TANK SELECTION

1

## DEPTH TO THE PUMPING WATER LEVEL

**0–25 feet:** Shallow well or convertible jet pump, install in shallow (single pipe) configuration.

**25–90 feet:** Convertible jet pump, installed in deep (two pipe) configuration or deep well submersible pump.

**0–250 feet:** Deep well submersible pump.

**250+ feet:** Call The Technical Service Line: 1.888.885.9254

**“Pumping water level”** is the depth to the water while the well is being pumped. It is usually deeper than the depth to the water when the pump is not running. For a lake or cistern installation, it is the depth to the surface of the water.

**For Jet pumps,** it is the vertical distance from the pumping water level to the suction opening of the pump.

**For Submersible pumps,** it is the vertical distance from the pumping water level to the point of water usage.

New installation information is available on the **Well Driller’s Report**. For replacement installations, use the equivalent style and horsepower pump, providing it was suitable when it was operational.

**NOTE:** A foot valve or check valve is required for proper operation of any system. The suction line must extend at least 5' below the pumping water level and be at least 10' above the well bottom.

## PUMP CHART

Read across the top of the chart for correct pumping water level in feet. Read down the side for correct flow required (gpm).

The letter(s) corresponds to the minimum recommended pump options. Higher horsepower models of the same categories may be substituted for jet pumps.

Flow Req. (GPM)	Pumping Water Level in Feet								
	5	15	25	50	80	100	150	200	250
3	A,D	A,D	A,D,G	D,G	D,G	G	G,H	H,I	I
4	A,D	A,D	A,D,G	D,G	E,G	G,H	G,H	H,I	I
5	A,D	A,D	A,E,G	D,G	F,G	G,H	G,H	H,I	I
6	A,D	A,D	B,E,G	D,G	G	G,H	H	I	I
7	A,D	A,D	B,E,G	F,G	G,H	G,H	H	I	I
8	A,D	A,E	C,F,G	G	G,H	G,H	H	I	I
9	A,D	A,E	C,G	G	G,H	G,H	I	I	J
10	A,D	B,E	C,G	G,H	G,H	G,H	I	I	J
11	A,E	B,E	G	G,H	H	H	I	J	J
12	A,E	C,E	G	G,H	H	H	I,J	J	J
13	B,E	C,F	G	G,H	H,I	I,J	J	J	J
14	B,E	C,F	G	I	I,J	J	J	J	J
15	B,E	C		I	J				
16	C,E	C							
17	C,E	C							

*NOTE: For depths greater than 250', consult tech support*

Shallow Jet Pumps	Convertible Jet Pumps	Deep Well Submersible Pumps
A = RJS-50-PREM ½ hp B = RJS-75-PREM ¾ hp C = RJS-100-PREM 1 hp	D = RJC-50-PREM ½ hp E = RJC-75-PREM ¾ hp F = RJC-100 1 hp	G = RL12G05 ½ hp H = RL12G07 ¾ hp I = RL12G10 1 hp J = RL12G15 1½ hp

2

## HOW MUCH WATER IS REQUIRED

The gpm (gallons per minute) of the pump must equal the total number of fixtures. Fixtures include all faucets, toilets, and water consuming appliances (do not include water treatment appliances, such as a hot water tank or water filter). Example: A house with one full bathroom (sink, tub/shower, toilet), kitchen sink, basement sink, outside faucet, washing machine, and dishwasher would require 8 gpm.

3

## MINIMUM WELL DIAMETER

**2½”** – Jet pumps in shallow well applications (depth less than 25') should be installed using 1-1/4" suction piping with a foot valve.

**4”** – Convertible jet pumps used in deep well applications (depth greater than 25') and deep well submersible pumps.



## TANK CHART

**NOTE:** Refer to Step 2 above.

The easy way to size a tank is take the gpm system requirement that you determined in Step 2, multiply by 3 and go to the next largest tank size.

**Example:** 8 gpm x 3 = 24 gallons – therefore use an RL33 tank.

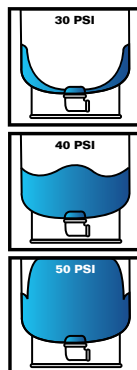

Model	Gallons	Drawdown @ 30/50 psi (gal)	Fixtures
RL2	2.1	0.7	-
RL4	4.8	1.5	-
RL8	8.5	2.6	-
RL6H	5.3	1.6	1
RL14H	14.0	4.3	4
RL16	15.9	4.9	5
RL20H	21.1	6.2	7
RL21	21.1	6.5	7
RL34	34.3	10.6	11
RL40	40.0	12.4	13
RL81	81.0	27.6	27
RL119	119.0	40.6	39



# TYPICAL INSTALLATIONS

## SHALLOW WELL JET PUMP (DOWN TO 25')

Suitable for applications where the pumping water level does not exceed 25'. Requires a single 1-1/4" suction pipe. May be used in wells 2" or larger in diameter.

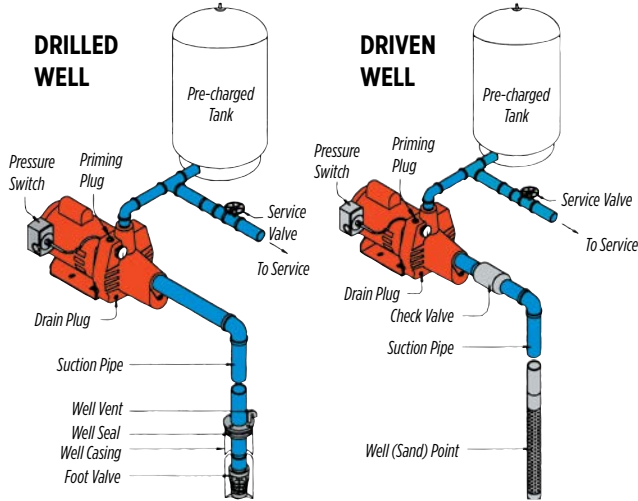

To complete installation, the following is required:

- Jet pump
- Pressure tank
- Pump-to-tank fittings
- 1-1/4" suction piping
- Foot valve or check valve

## CONVERTIBLE JET PUMP (SHALLOW WELL CONFIGURATION DOWN TO 25')

Suitable for applications where the pumping water level does not exceed 25'. Requires a single 1-1/4" suction pipe. May be used in wells 2-1/2" or larger in diameter.

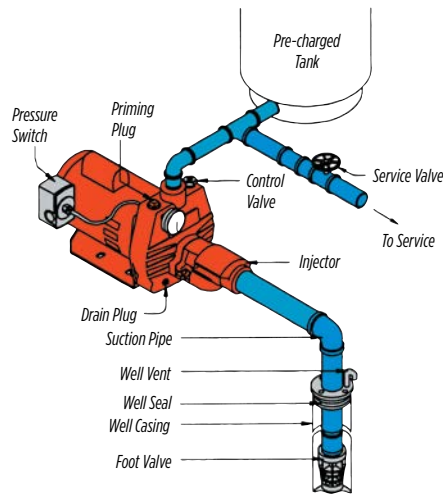

To complete installation:

- Jet pump; includes pressure switch, flow control valve, injector
- Pressure tank
- Pump-to-tank fittings
- 1-1/4" suction piping
- Foot valve or check valve (for driven well)

## CONVERTIBLE JET PUMP (DEEP WELL CONFIGURATION DOWN TO 90')

Suitable for applications where the pumping water level does not exceed 90'. Requires a double suction pipe. May be used in wells 4" or larger in diameter.

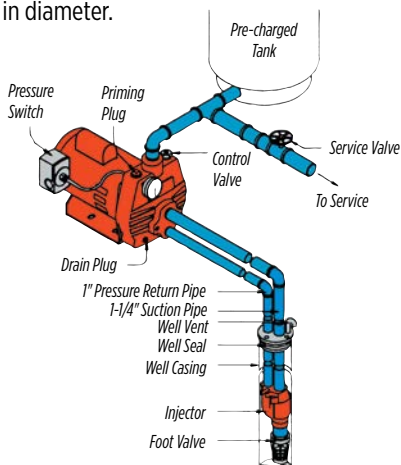

To complete installation:

- Jet pump; includes pressure switch, flow control valve, injector (installed in the well)
- Pressure tank
- Pump-to-tank fittings
- 1-1/4" suction piping and 1" pressure return piping
- Foot valve

## DEEP WELL SUBMERSIBLE PUMP (DOWN TO 250')

Suitable for applications where the pumping water level does not exceed 250'. May be used in wells 4" or larger in diameter.

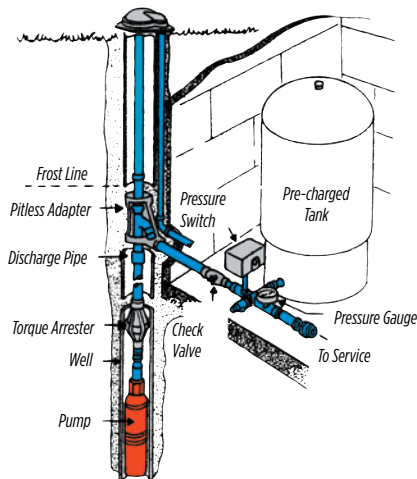

To complete installation:

- Submersible pump sub-pac; includes pressure switch, pressure gauge, service tee, relief valve, sub cable, built-in check valve
- Pressure tank
- Torque arrester
- Well seal or pitless adapter
- 1" discharge piping

# CAST IRON SPRINKLER UTILITY PUMP

## APPLICATIONS

Ideal for pressure boosting, sprinkler systems, and general purpose applications where portability is important.

## FEATURES & BENEFITS

- 115 Volt motor with 8' power cord
- Rugged cast iron construction
- Steel handle for portability
- Easy to prime to 25'; no additional priming required after initial fill
- Garden hose adapter included



Model	Item No.	UPC	HP	Volts	Amps	Cord Length	Intake	Discharge	Suction Lift	Discharge Pressure (PSI)										Max. Press. (PSI)	Max. Flow (GPM)
										20	25	30	35	40	45	50	55	60	Gallons Per Minute		
RJSE-50	614430	0 10121 12456 1	1/2	115	12.4 A @ 115 V	8'	1-1/4" FNPT	1" FNPT	5'	12.8	12.5	12.3	12.1	11.2	9.5	6.9	4.3	2.0	64.2	12.8	
									10'	11.5	11.3	11.0	10.8	10.4	8.5	6.0	3.4	1.0	62.0		
									15'	9.8	9.7	9.6	9.5	9.4	7.3	4.7	2.0	-	59.9		
									20'	8.3	8.1	7.8	7.7	7.6	5.7	3.5	1.0	-	57.7		
									25'	5.6	5.55	5.5	5.4	5.3	4.1	2.3	0.2	-	55.5		

## CARTON SPECIFICATIONS

Model	Length	Width	Height	Weight (lbs)	Carton Cubes (cu ft)	Pallet Quantity	Quantity per Layer	Layers per Pallet
RJSE-50	10"	20.25"	11.5"	36	1.35	32	8	4

Cast Iron Sprinkler Utility Pump

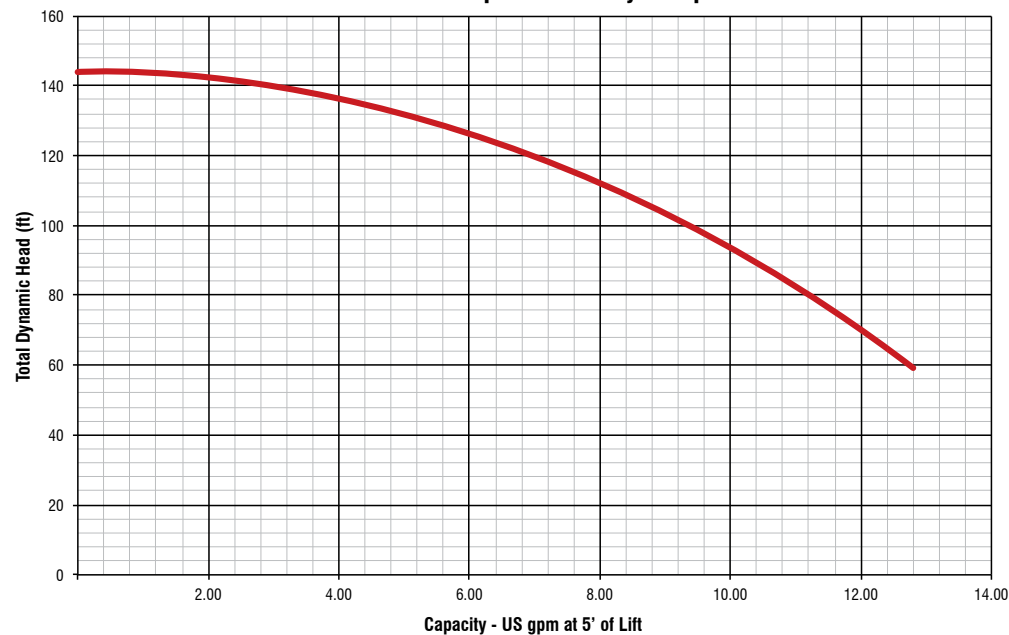

# STAINLESS STEEL SPRINKLER UTILITY PUMP

## APPLICATIONS

Ideal for pressure boosting, sprinkler systems, and general purpose applications where portability and corrosion-resistance is important.



## FEATURES & BENEFITS

- Easy to prime to 25'; no additional priming required after initial fill
- Corrosion-resistant stainless steel pump housing is ideal for operating lawn sprinklers, pressure boosting, and other general purpose applications and is suitable for aggressive water conditions
- Heavy-duty 3/4 hp 115 V motor for years of service and reliability
- Glass-filled thermoplastic impeller and diffuser for high performance and efficient water flow
- Power cord, carry handle, and garden hose adapter included for convenience and portability

Model	Item No.	UPC	HP	Volts	Amps	Cord Length	Intake	Discharge	Discharge Pressure (PSI) at 5' Lift							Max. Flow (GPM) at 5' Suction Lift	Max. Pressure (PSI)	Max. Head (ft)
									0	10	20	30	40	50	60			
RJSE-75SS	614432	0 10121 14415 6	3/4	115	6.5 A	8'	1"	1" FNPT	11	9.5	9.0	7.3	4.6	2.3	0.4	11	64	147

## CARTON SPECIFICATIONS

Model	Length	Width	Height	Weight (lbs)	Carton Cubes (cu ft)	Pallet Quantity	Quantity per Layer	Layers per Pallet
RJSE-75SS	9.8"	15"	11.8"	21	0.69	48	12	4

Stainless Steel Sprinkler Utility Pump



# SPRINKLER PUMP

## APPLICATIONS

Ideal for both residential and commercial lawn and turf sprinkling systems.

## FEATURES & BENEFITS

- Rugged cast iron casing and pump base
- High efficiency thermoplastic impeller and diffuser
- BR models are configured with a brass impeller which is recommended for more demanding applications such as weir feeders\*
- Easy to prime to 25'; no additional priming required after initial fill



RL-SPRK100



RL-SPRK200

Model	Item No.	UPC	HP	Volts	Amps	Intake	Discharge	Discharge Pressure (PSI) at 5' Lift				Max. Press. (PSI)	Max. Flow (GPM)
								10	20	30	40		
RL-SPRK100	97101001	0 10121 00139 8	1	115/230	14 A @ 115 V / 7 A @ 230 V	2" FNPT	1-1/2" FNPT	63	54	38	11	45	63
RL-SPRK150	97101501	0 10121 00140 4	1-1/2	115/230	18.6 A @ 115 V / 9.3 A @ 230 V	2" FNPT	1-1/2" FNPT	71	60	44	15	44	71
RL-SPRK200	97102001	0 10121 00141 1	2	230	10.9 A @ 230 V	2" FNPT	1-1/2" FNPT	76	75	65	47	49	76
*RL-SPRK-150-BR	97101502	0 10121 00142 8	1-1/2	115/230	18.6 A @ 115 V / 9.3 A @ 230 V	2" FNPT	1-1/2" FNPT	71	60	44	15	41	71
*RL-SPRK-200-BR	97102002	0 10121 00143 5	2	230	10.9 A @ 230 V	2" FNPT	1-1/2" FNPT	77	75	64	48	47	77

## CARTON SPECIFICATIONS

Model	Length	Width	Height	Weight (lbs)	Carton Cubes (cu ft)	Pallet Quantity	Quantity per Layer	Layers per Pallet
RL-SPRK100	11.5"	22"	12.25"	25.02	1.79	18	3	6
RL-SPRK150	11.5"	22"	12.25"	29.32	1.79	18	3	6
RL-SPRK200	11.5"	22"	12.25"	29.15	1.79	18	3	6
*RL-SPRK-150-BR	11.5"	22"	12.25"	30.07	1.79	18	3	6
*RL-SPRK-200-BR	11.5"	22"	12.25"	30.07	1.79	18	3	6

### Centrifugal Sprinkler Pumps

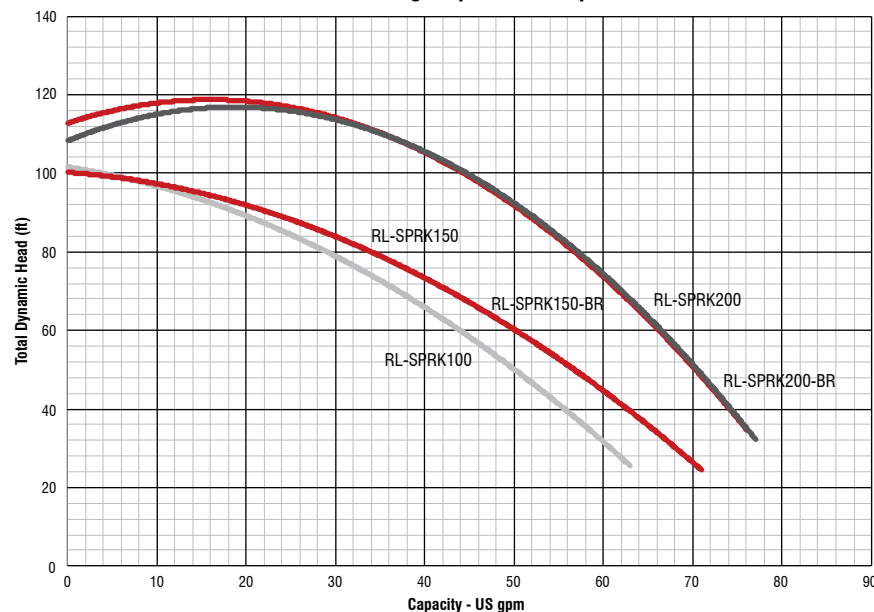

# CAST IRON INDUSTRIAL SPRINKLER PUMP

## APPLICATIONS

Ideal for both large residential properties and commercial lawn and turf sprinkling systems.

## FEATURES & BENEFITS

- Heavy-duty iron casing, diffuser, and seal plate for years of service and reliability
- High efficiency cast iron impeller and diffuser for high-performance and efficient water flow
- 2" suction and 2" discharge helps to prevent debris from clogging impellers and maintain full-flow performance
- Easy to prime to 25'; no additional priming required after initial fill



\*Color of motor may vary

Model	Item No.	UPC	HP	Volts	Amps	Intake	Discharge	Discharge Pressure (PSI) at 5' Lift							Max. Pressure (PSI)	Max. Flow (GPM)
								10	20	30	40	45	50	55		
RLHE-300	614481	0 10121 12461 5	3	115/230	32.2 A @ 115 V 16.1 A @ 230 V	2" NPT	2" NPT	124	110	95	77	67	54	36	59	124

## CARTON SPECIFICATIONS

Model	Length	Width	Height	Weight (lbs)	Carton Cubes (cu ft)	Pallet Quantity	Quantity per Layer	Layers per Pallet
RLHE-300	26.5"	13.375"	15"	135	3.08	3	3	1

NOTE: This unit is shipped in a plain carton

Cast Iron Industrial Sprinkler Pump

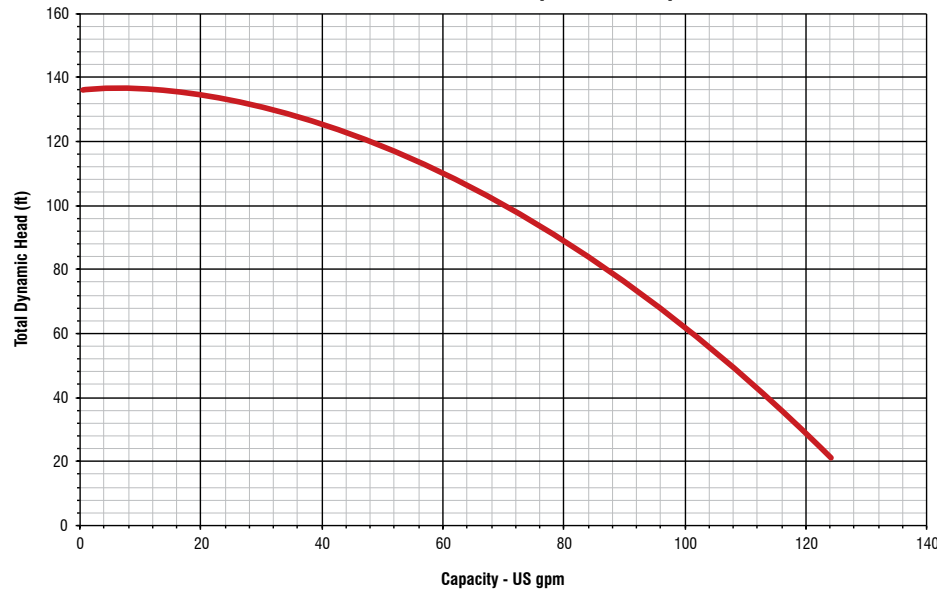

# THERMOPLASTIC SUMP PUMPS

## APPLICATIONS

Ideal for light- to high-volume water removal in residential spaces such as basements and crawl spaces.

## FEATURES & BENEFITS

- Automatic submersible sump pumps
- 1-1/2" FNPT discharge with 1-1/4" FNPT adapter included
- Piggyback float switch
- PSC motor and closed vane impeller design
- Double seal system
- 8' cord



RL-SP50T

RL-SP50V

Model	Item No.	UPC	HP	Volts	Switch	Amps	Cord Length	Gallons Per Hour at Height					Shut-Off	On/Off Levels	Min. Basin Diameter
								0'	5'	10'	15'	20'			
RL-SP25T	14942739	0 10121 14162 9	1/4	115	Tethered	6.0	8'	2900	2640	2100	1560	540	23'	On: 14.5" Off: 5.5"	14" or more
RL-SP33T	14942740	0 10121 14163 6	1/3	115	Tethered	4.4	8'	3200	2880	2520	1680	1260	25'	On: 14.5" Off: 5.5"	14" or more
RL-SP33V	14942741	0 10121 14164 3	1/3	115	Vertical	4.4	8'	3200	2880	2520	1680	1260	25'	On: 7.25" Off: 2.75"	11" or more
RL-SP50T	14942742	0 10121 14165 0	1/2	115	Tethered	4.4	8'	3600	3060	2520	1920	1320	28'	On: 14.5" Off: 5.5"	14" or more
RL-SP50V	14942743	0 10121 14166 7	1/2	115	Vertical	4.4	8'	3600	3060	2520	1920	1320	28'	On: 7.25" Off: 2.75"	11" or more

## CARTON SPECIFICATIONS

Model	Length	Width	Height	Weight (lbs)	Carton Cubes (cu ft)	Pallet Quantity	Quantity per Layer	Layers per Pallet
RL-SP25T	7.5"	9.25"	11.75"	9.5	0.47	104	26	4
RL-SP33T	7.5"	9.25"	11.75"	11.5	0.47	104	26	4
RL-SP33V	9.05"	9.25"	13.5"	11	0.65	60	20	3
RL-SP50T	7.75"	9.25"	11.75"	14	0.49	104	26	4
RL-SP50V	9.05"	9.25"	13.5"	13	0.65	60	20	3

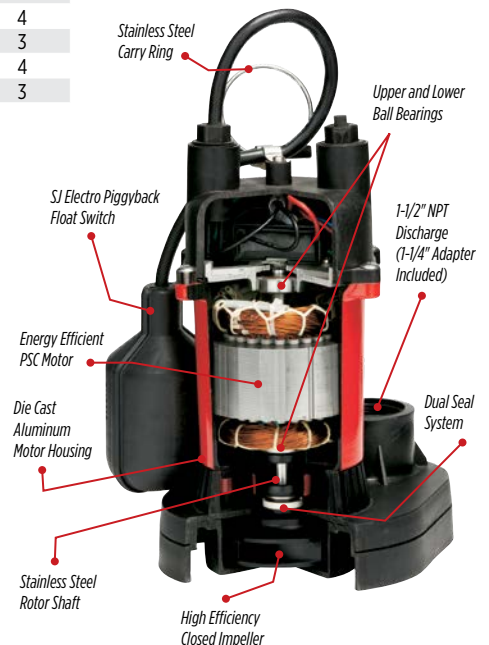
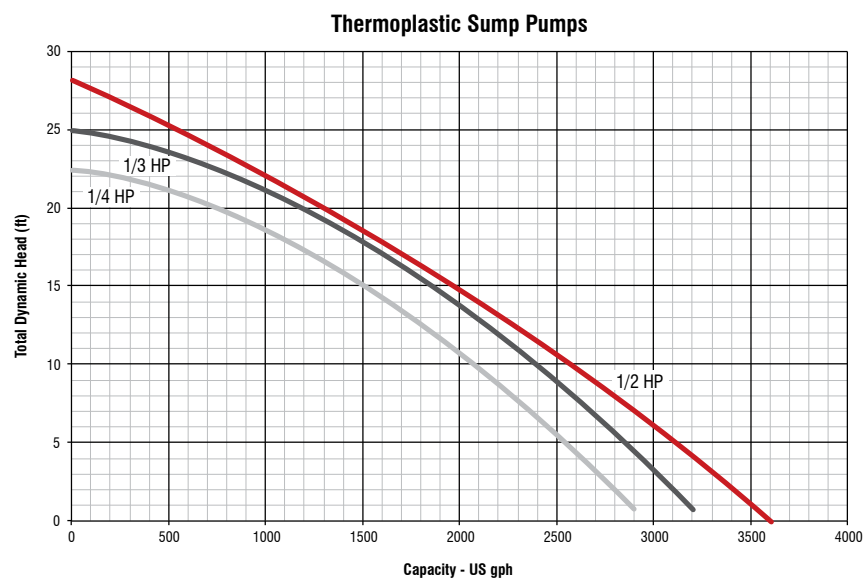

# STAINLESS STEEL SUMP PUMPS

## APPLICATIONS

Ideal for average to high-volume water removal in residential spaces such as basements and crawl spaces.

## FEATURES & BENEFITS

- A standard 300-grade stainless steel motor housing provides added corrosion protection for maximum pump life
- An energy-efficient PSC motor draws fewer amps to reduce electricity costs
- Contractor-preferred snap-action float switch for reliable automatic operation
- An elevated suction design provides superior clog-resistance



Model	Item No.	UPC	HP	Volts	Amps	Watts	Cord Length	Discharge	Gallons Per Hour at Height					Shut-Off	On/Off Levels	Minimum Basin Diameter
									5'	10'	15'	20'	25'			
RL33CSS	14942793	0 10121 00165 7	1/3	115	3.5	400	10'	1-1/2" FNPT	3500	2800	2000	500	-	23'	On: 9"-11" Off: 3"-5"	18"
RL50CSS	14942794	0 10121 00166 4	1/2	115	4	450	10'	1-1/2" FNPT	3900	3150	2250	1500	-	25'	On: 9"-11" Off: 3"-5"	18"
RL75CSS	14942795	0 10121 00167 1	3/4	115	5.5	650	10'	1-1/2" FNPT	4500	4000	3200	2500	1500	30'	On: 9"-11" Off: 3"-5"	18"

## CARTON SPECIFICATIONS

Model	Length	Width	Height	Weight (lbs)	Carton Cubes (cu ft)	Pallet Quantity	Quantity per Layer	Layers per Pallet
RL33CSS	11.4"	8.5"	14.6	21.5	0.82	48	16	3
RL50CSS	11.4"	8.5"	14.6	21.6	0.82	48	16	3
RL75CSS	11.4"	8.5"	14.6	23.3	0.82	48	16	3

Stainless Steel Sump Pumps

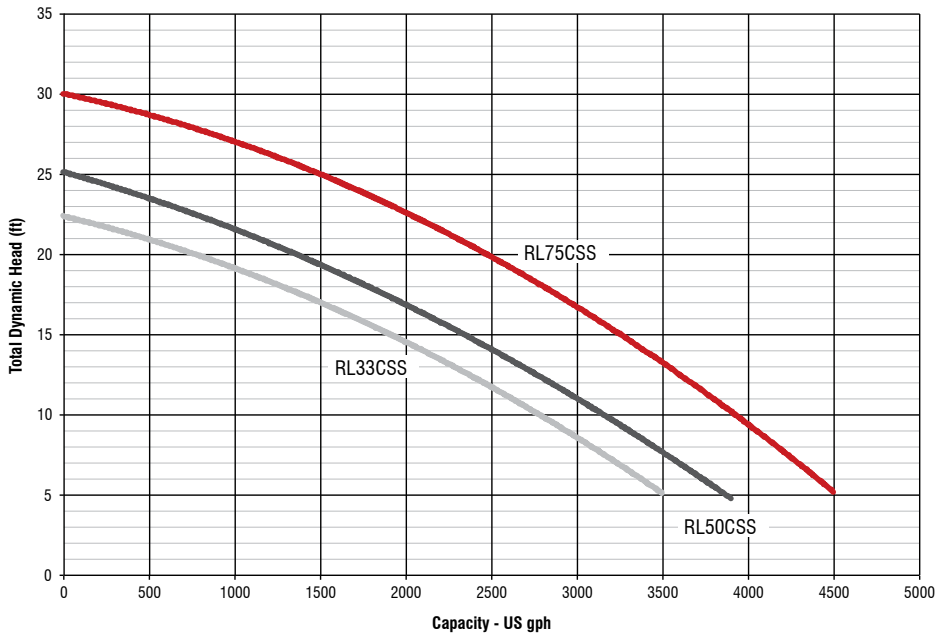

# CAST IRON SUMP PUMPS

## APPLICATIONS

Ideal for average- to high-volume water and effluent removal in residential spaces such as basements, laundry facilities, and crawl spaces.

## FEATURES & BENEFITS

- Automatic submersible sump pumps
- 1-1/2" FNPT discharge
- Piggyback float switch
- Clog-resistant design (3/8" semi-solids handling)
- PSC motor
- 10' cord



RL-SC50T

RL-SC50V

Model	Item No.	UPC	HP	Switch	Volts	Amps	Cord Length	Gallons Per Hour at Height					Shut-Off	On/Off Levels	Min. Basin Diameter
								0'	5'	10'	15'	20'			
RL-SC33T	14942744	0 10121 14167 4	1/3	Tethered	115	4.3	10'	3350	3000	2460	1860	960	25'	On: 13" Off: 5"	18" or more
RL-SC33V	14942745	0 10121 14168 1	1/3	Vertical	115	4.3	10'	3350	3000	2460	1860	960	25'	On: 7.25" Off: 2.75"	11" or more
RL-SC50T	14942746	0 10121 14169 8	1/2	Tethered	115	5.3	10'	4300	3840	3000	2220	1440	28'	On: 13" Off: 5"	18" or more
RL-SC50V	14942747	0 10121 14170 4	1/2	Vertical	115	5.3	10'	4300	3840	3000	2220	1440	28'	On: 7.25" Off: 2.75"	11" or more

## CARTON SPECIFICATIONS

Model	Length	Width	Height	Weight (lbs)	Carton Cubes (cu ft)	Pallet Quantity	Quantity per Layer	Layers per Pallet
RL-SC33T	7.25"	8.75"	13"	20	0.48	81	27	3
RL-SC33V	6.75"	8.75"	13"	21	0.44	81	27	3
RL-SC50T	7.25"	8.75"	13"	20	0.48	75	25	3
RL-SC50V	6.75"	8.75"	13"	21	0.44	75	25	3

### Cast Iron Sump Pumps

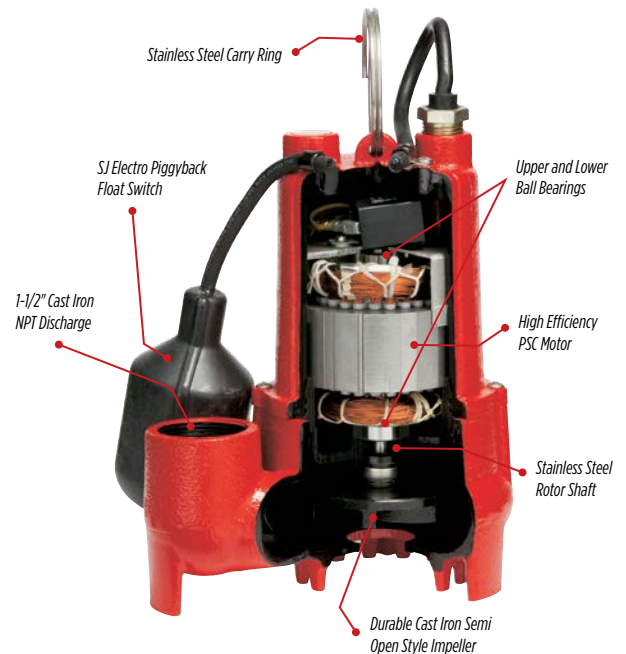
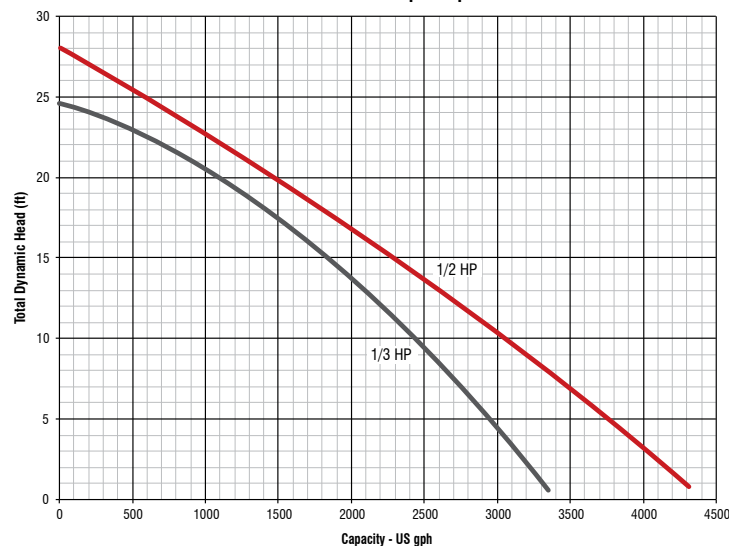

# 1/3 HP DUAL CAST IRON SUMP PUMP SYSTEM

## APPLICATIONS

Ideal for average- to high-volume water removal in residential spaces such as basements, laundry facilities, and crawl spaces. This system offers worry-free operation, providing you with a back-up pump and double the flow rate when needed.\*

## FEATURES & BENEFITS

- Dual automatic submersible sump pumps
- Pre-assembled piping and check valves included
- Maximum head of 25'
- 10' power cord
- 1-1/2" FNPT discharges
- Piggyback float switches
- Clog-resistant design (3/8" semi-solids handling)
- PSC motors



Model	Item No.	UPC	HP	Volts	Switch	Discharge	Cord Length	Operation	Gallons Per Hour at Height					Shut-Off	On/Off Levels	Min. Basin Diameter
									0'	5'	10'	15'	20'			
RL-SC33DUP	14942771	0 10121 14606 8	1/3	115	Vertical	1-1/2" FNPT	10'	Single Pump Dual Pump	3350 6000	3000 5400	2460 4425	1860 3345	960 1725	25'	On: 7.25" Off: 2.75"	18"

## CARTON SPECIFICATIONS

Model	Length	Width	Height	Weight (lbs)	Carton Cubes (cu ft)	Pallet Quantity	Quantity per Layer	Layers per Pallet
RL-SC33DUP	9.5"	17.25"	14"	45	1.33	24	8	3

Single Pump vs. Dual Pump Operation

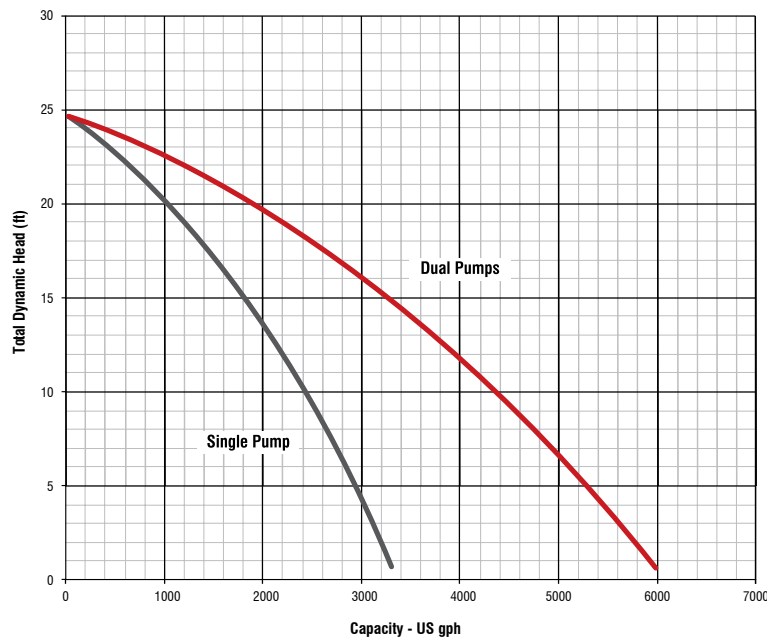

NOTE: Friction loss in pipe not included

# SNAP-ACTION CAST IRON SUMP/EFFLUENT PUMPS

## APPLICATIONS

Ideal for average- to high-volume water and effluent removal in residential spaces such as basements, laundry facilities, and crawl spaces.

## FEATURES & BENEFITS

- Automatic submersible cast iron sump/effluent pump
- 1-1/2" FNPT discharge
- Integrated snap-action float switch suitable for use in narrow basins (11" or greater)
- Solid float will never become waterlogged
- Built-in rod protection prevents float from contacting basin
- Clog-resistant design (1/2" diameter semi-solids handling)
- 10' cord



Model	Item No.	UPC	HP	Volts	Amps	Discharge	Cord Length	Gallons Per Hour at Height					Shut-Off	On/Off Levels	Basin Diameter
								5'	10'	15'	20'	30'			
RL-33SC	14942652	0 10121 14579 5	1/3	115	5	1-1/2" FNPT	10'	3200	3000	2500	2200	-	28'	On: 8"-11" Off: 2"-5"	11" or more
RL-50SC	14942653	0 10121 14580 1	1/2	115	6.5	1-1/2" FNPT	10'	4000	3420	3090	2800	1680	36'	On: 8"-11" Off: 2"-5"	11" or more

## CARTON SPECIFICATIONS

Model	Length	Width	Height	Weight (lbs)	Carton Cubes (cu ft)	Pallet Quantity	Quantity per Layer	Layers per Pallet
RL-33SC	9.75"	11"	12.75"	27.75	0.79	48	16	3
RL-50SC	10.25"	11.50"	13.75"	28.46	0.94	36	12	3

Snap-Action Sump/Effluent Pumps

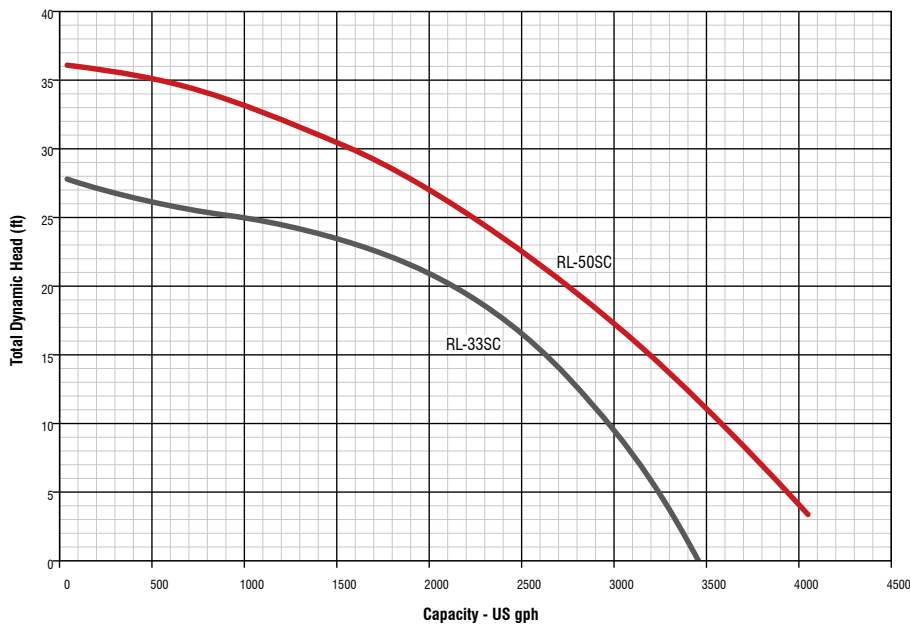

# PREMIUM SUBMERSIBLE STAINLESS STEEL SUMP PUMPS

## APPLICATIONS

Ideal for high-volume water removal in residential spaces such as basements and crawl spaces.

## FEATURES & BENEFITS

- Automatic submersible stainless steel sump pump ideal for aggressive water applications
- Heavy-duty stainless steel and cast iron construction for years of service and reliability
- Clog-resistant design is capable of passing 3/4" diameter semi-solids
- Piggyback float switch for reliable automatic operation



RL-SS50T

RL-SS100T

RL-SS50V

Model	Item No.	UPC	HP	Volts	Switch	Discharge	Amps	Cord Length	Gallons Per Hour at Height						Shut-Off	On/Off Levels	Min. Basin Diameter
									0'	5'	10'	15'	20'	30'			
RL-SS50V	14942780	0 10121 14436 1	1/2	115	Vertical	1-1/2" FNPT	5	10'	3450	3000	2400	1800	-	-	25'	On: 7.5" Off: 4.5"	11" or more
RL-SS50T	14942781	0 10121 14437 8	1/2	115	Tethered	1-1/2" FNPT	5	10'	3450	3000	2400	1800	-	-	25'	On: 13.8"-14.8" Off: 5.5"-6.5"	18" or more
RL-SS100T	14942782	0 10121 14438 5	1	115	Tethered	2" FNPT 1-1/2" FNPT adapter incl.	8	20'	5300	4800	4300	3700	3000	1300	35'	On: 15"-18" Off: 7"-10"	18" or more

## CARTON SPECIFICATIONS

Model	Length	Width	Height	Weight (lbs)	Carton Cubes (cu ft)	Pallet Quantity	Quantity per Layer	Layers per Pallet
RL-SS50V	7.12"	10"	17"	22.5	0.70	40	20	2
RL-SS50T	7"	10.5"	17"	22.5	0.72	40	20	2
RL-SS100T	10"	11"	18"	33.6	1.15	32	16	2

Premium Submersible Stainless Steel Sump Pumps

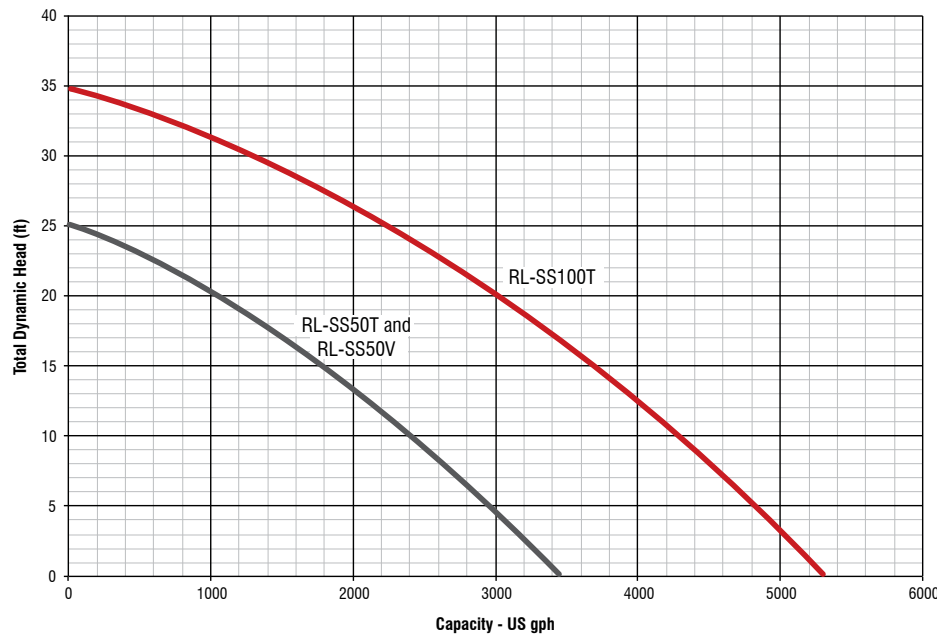

# PEDESTAL PUMPS

## APPLICATIONS

Ideal for average-volume water removal in residential spaces such as basements and crawl spaces.

## FEATURES & BENEFITS

- Automatic pedestal sump pumps (column style)
- Poly or cast iron models available
- Adjustable snap-action float switch
- Clog-resistant design



SC33PED



SP33PED

Model	Item No.	UPC	HP	Volts	Discharge	Amps	Cord Length	Construction	Gallons Per Hour at Height				Shut-Off	Min. Basin Diameter
									0'	5'	10'	15'		
SP33PED	14942050	0 10121 11814 0	1/3	115	1-1/4" FNPT	4	8'	Thermoplastic	3300	2800	2040	620	17'	11" or more
SC33PED	14942051	0 10121 11815 7	1/3	115	1-1/4" FNPT	4	8'	Cast Iron	3500	3310	2550	600	17'	11" or more

## CARTON SPECIFICATIONS

Model	Retail Carton			Protective Outer Carton			Weight (lbs)	Carton Cubes (cu ft)	Pallet Quantity	Quantity per Layer	Layers per Pallet
	Length	Width	Height	Length	Width	Height					
SP33PED	8.25"	9"	33"	8.75"	10"	34"	14	1.42	20	20	1
SC33PED	8.25"	9"	33"	8.75"	10"	34"	20	1.42	20	20	1

### Pedestal Pumps

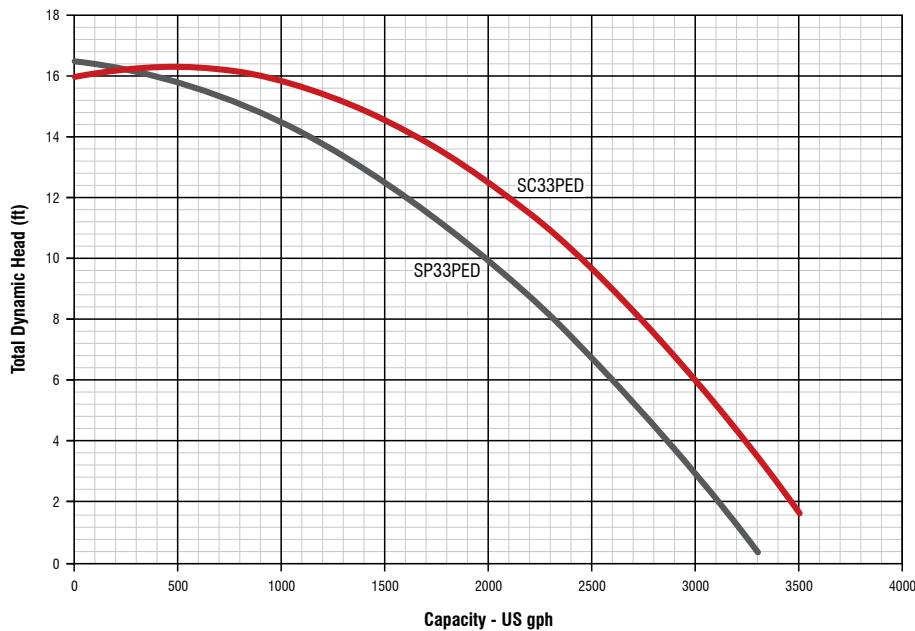

# UNDER-SINK SUMP PACKAGE

## APPLICATIONS

Ideal for water removal from impractical gravity drainage areas and residential spaces such as under sinks and laundry trays.

## FEATURES & BENEFITS

- 1/3 hp sump pump
- Engineered thermoplastic construction
- 6 gallon polypropylene basin
- Pre-assembled water removal system
- Up to 3200 gph



Model	Item No.	UPC	HP	Switch	Volts	Discharge	Vent	Amps	Cord Length	Gallons Per Hour at Height					Shut-Off	Basin Size
										0'	5'	10'	15'	20'		
RL-SPS33	14942736	0 10121 14159 9	1/3	Vertical	115	1-1/2" FNPT	1-1/2" FNPT	4.4	8'	3200	2880	2520	1680	1260	25'	6 Gallon

## CARTON SPECIFICATIONS

Model	Length	Width	Height	Weight (lbs)	Carton Cubes (cu ft)	Pallet Quantity	Quantity per Layer	Layers per Pallet
RL-SPS33	15"	15"	13.5"	18.5	1.76	18	6	3

Under Sink Sump Package

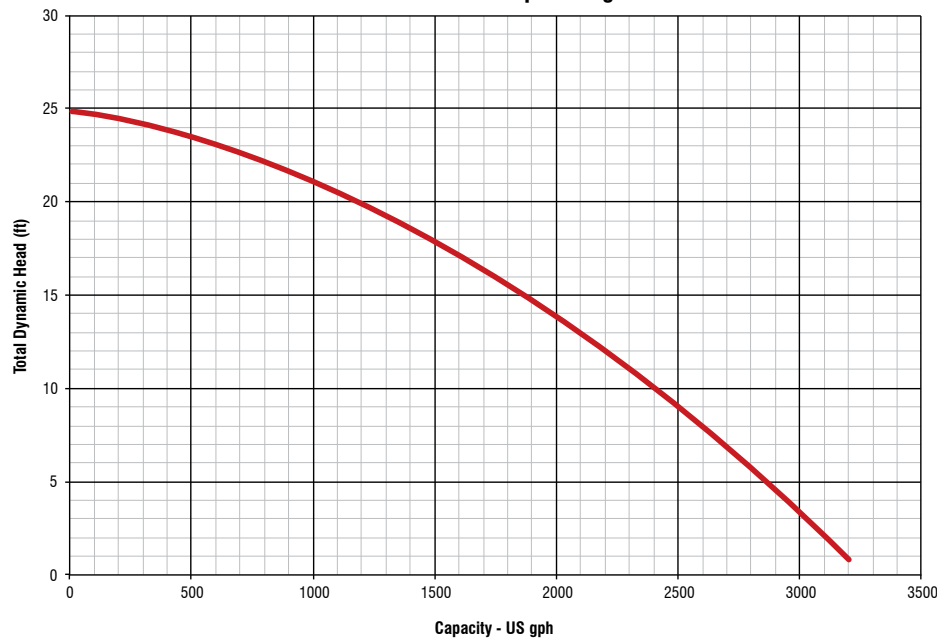

# BATTERY BACKUP SYSTEM

## APPLICATIONS

Provides emergency protection from water damage due to primary sump pump failure or power outages in residential areas such as basements and crawl spaces.

## FEATURES & BENEFITS

- Automatic sump pump back-up system
- 12 Volt DC/1000 mA battery charger with alarm
- System includes charger, pump, 1-1/2" street elbow, 1-1/2" check valve, 1-1/2" coupling, battery box, vertical float switch



Model	Item No.	UPC	Switch	Volts	Discharge	Amps	Cord Length	Gallons Per Hour at Height				Shut-Off	Basin Diameter
								0'	5'	10'	15'		
RL-SPBS	14942792	0 10121 15095 9	Diaphragm	Pump: 12 V DC Charger: 120 V	1-1/2"	14	Charger: 6'	2500	1750	1200	500	18'	11" or more

## CARTON SPECIFICATIONS

Model	Length	Width	Height	Weight (lbs)	Carton Cubes (cu ft)	Pallet Quantity	Quantity per Layer	Layers per Pallet
RL-SPBS	15.25"	15.25"	13.5"	17	1.79	18	6	3

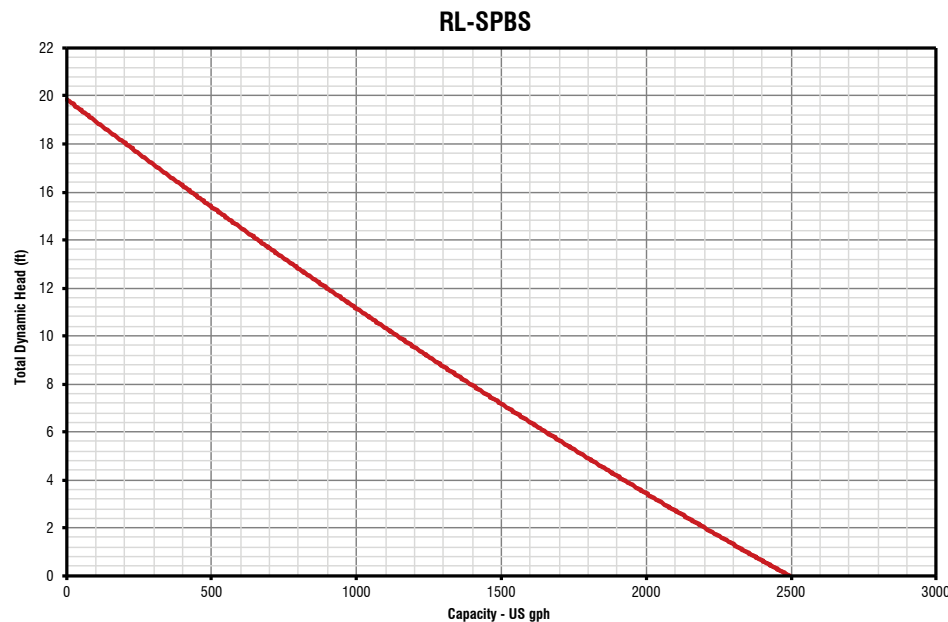

Recommended Installation

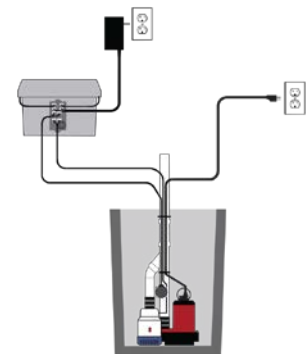



# CAST IRON SURFACE EFFLUENT PUMP

## APPLICATIONS

Ideal for pumping liquid from septic tanks, as well as pumping out flooded basements, irrigation, and general dewatering.

## FEATURES & BENEFITS

- Easy to prime to 25'; no additional priming required after initial fill
- Built-in check valve
- Rugged cast iron casing
- Heavy-duty motor, 115/230 Volts
- Cast iron impeller



Model	Item No.	UPC	HP	Volts	Discharge	Gallons Per Hour at Height				Shut-Off	Max. Pressure (PSI)
						20'	30'	40'	50'		
RL-S50	621810	0 10121 12643 5	1/2	115/230	1-1/4" FNPT	2700	1860	960	-	49'	21

## CARTON SPECIFICATIONS

Model	Length	Width	Height	Weight (lbs)	Carton Cubes (cu ft)	Pallet Quantity	Quantity per Layer	Layers per Pallet
RL-S50	10.25"	20"	11.75"	42	1.39	32	8	4

Cast Iron Surface Effluent Pumps

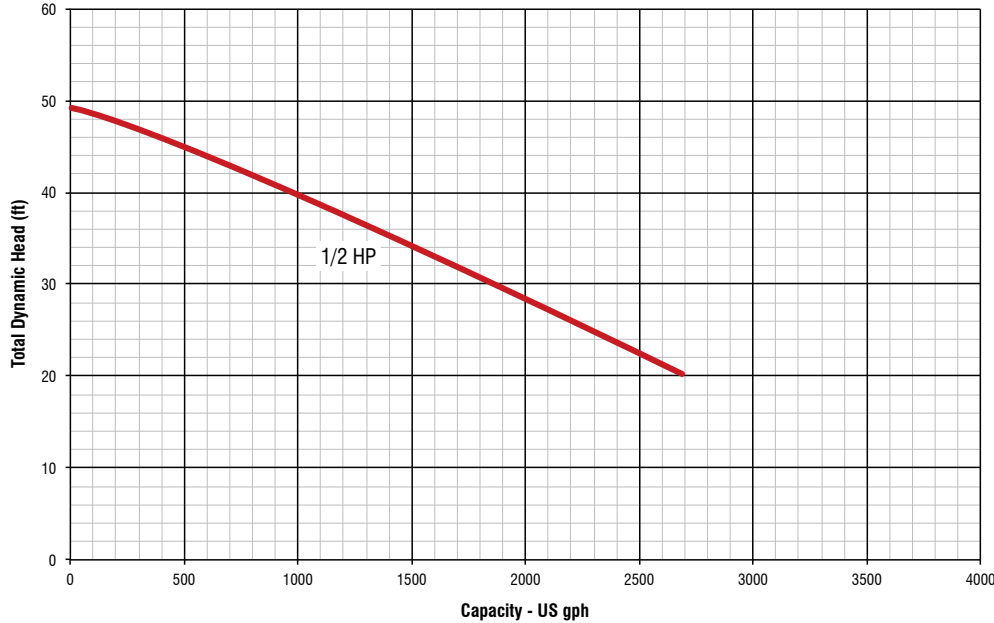

# SNAP-ACTION CAST IRON SUMP/EFFLUENT PUMPS

## APPLICATIONS

Ideal for average- to high-volume water and effluent removal in residential spaces such as basements, laundry facilities, and crawl spaces.

## FEATURES & BENEFITS

- Automatic submersible cast iron sump/effluent pump
- 1-1/2" FNPT discharge
- Integrated snap-action float switch suitable for use in narrow basins (11" or greater)
- Solid float will never become waterlogged
- Built-in rod protection prevents float from contacting basin
- Clog-resistant design (1/2" diameter semi-solids handling)
- 10' cord



Model	Item No.	UPC	HP	Volts	Amps	Discharge	Cord Length	Gallons Per Hour at Height					Shut-Off	On/Off Levels	Basin Diameter
								5'	10'	15'	20'	30'			
RL-33SC	14942652	0 10121 14579 5	1/3	115	5	1-1/2" FNPT	10'	3200	3000	2500	2200	-	28'	On: 8"-11" Off: 2"-5"	11" or more
RL-50SC	14942653	0 10121 14580 1	1/2	115	6.5	1-1/2" FNPT	10'	4000	3420	3090	2800	1680	36'	On: 8"-11" Off: 2"-5"	11" or more

## CARTON SPECIFICATIONS

Model	Length	Width	Height	Weight (lbs)	Carton Cubes (cu ft)	Pallet Quantity	Quantity per Layer	Layers per Pallet
RL-33SC	9.75"	11"	12.75"	27.75	0.79	48	16	3
RL-50SC	10.25"	11.50"	13.75"	28.46	0.94	36	12	3

Snap-Action Sump/Effluent Pumps

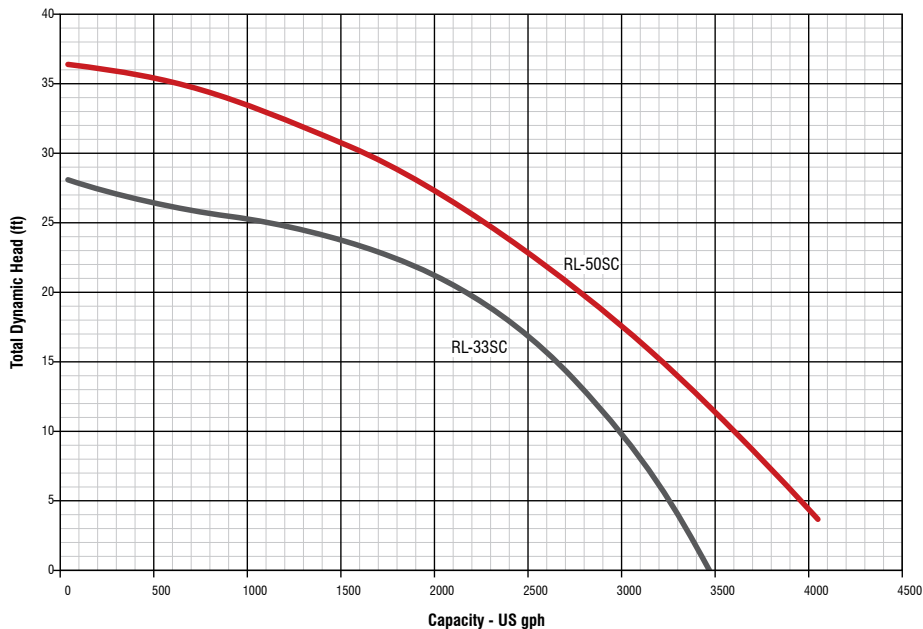

# PREMIUM SUBMERSIBLE STAINLESS STEEL SUMP/EFFLUENT PUMPS

## APPLICATIONS

Ideal for high volume water and effluent removal in residential spaces such as basements, laundry facilities, and crawl spaces.

## FEATURES & BENEFITS

- Automatic submersible sump pump is ideal for high-volume water removable applications
- Heavy-duty stainless steel and cast iron construction for years of service and reliability
- Clog-resistant design is capable of passing 3/4" diameter semi-solids
- Tethered float switch for reliable automatic operation for use in basins 15" diameter or greater



RL-SS50T

RL-SS100T

Model	Item No.	UPC	HP	Volts	Amps	Discharge	Cord Length	Gallons Per Hour at Height						Shut-Off	Min. Basin Diameter	On/Off Levels
								0'	5'	10'	15'	20'	30'			
RL-SS50T	14942781	0 10121 14437 8	1/2	115	5	1-1/2" FNPT	10'	3450	3000	2400	1800	-	-	25'	18" or more	On: 13.8"-14.8" Off: 5.5"-6.5"
RL-SS100T	14942782	0 10121 14438 5	1	115	8	2" FNPT 1-1/2" FNPT adapter incl.	20'	5300	4800	4300	3700	3000	1300	35'	18" or more	On: 15"-18" Off: 7"-10"

## CARTON SPECIFICATIONS

Model	Length	Width	Height	Weight (lbs)	Carton Cubes (cu ft)	Pallet Quantity	Quantity per Layer	Layers per Pallet
RL-SS50T	7"	10.5"	17"	22.5	0.72	40	20	2
RL-SS100T	10"	11"	18"	33.6	1.15	32	16	2

Premium Submersible Stainless Steel Sump/Effluent Pumps

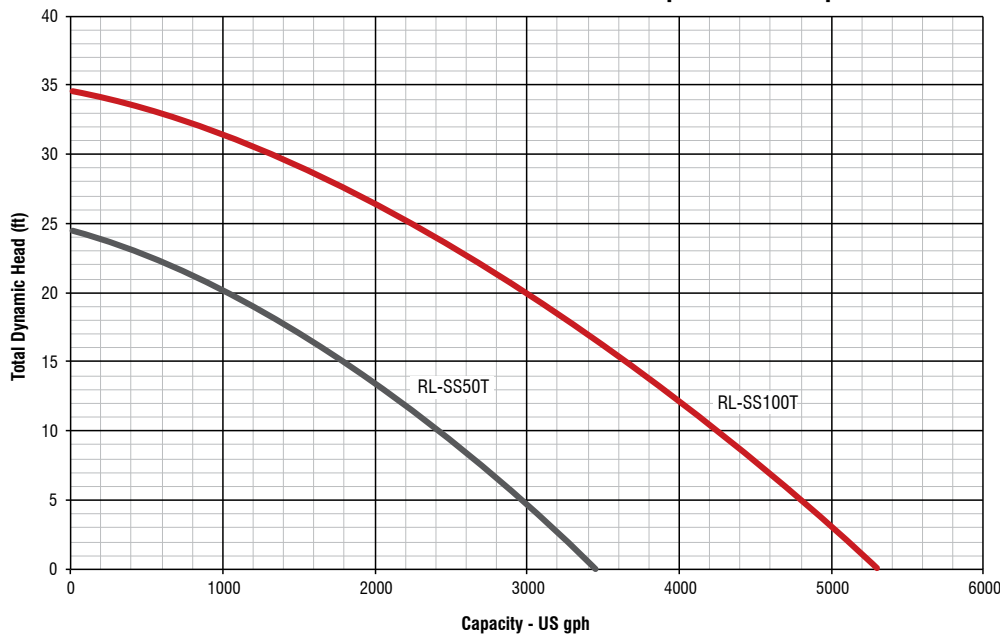

# SEWAGE PUMP

## APPLICATIONS

Ideal for high volume raw sewage removal applications.

## FEATURES & BENEFITS

- Automatic submersible cast iron sewage pump ideal for high volume sewage, effluent and wastewater needs
- Clog-resistant design capable of passing 2" diameter solids
- Heavy-duty cast iron construction for years of service and reliability
- Tethered float switch for reliability in automatic operation in basins 18" diameter or greater



RL50WA

Model	Item No.	UPC	HP	Volts	Amps	Discharge	Cord Length	Gallons Per Hour at Height					Shut-Off	On/Off Levels	Min. Basin Diameter
								0'	5'	10'	15'	20'			
RL50WA	14942663	0 10121 00060 5	1/2	115	9.3	2" FNPT	20'	7200	6000	4800	3180	1200	22'	On: 16"-18" Off: 9"-11"	18" or more

## CARTON SPECIFICATIONS

Model	Length	Width	Height	Weight (lbs)	Carton Cubes (cu ft)	Pallet Quantity	Quantity per Layer	Layers per Pallet
RL50WA	11"	13.5"	16"	50	1.38	27	9	3

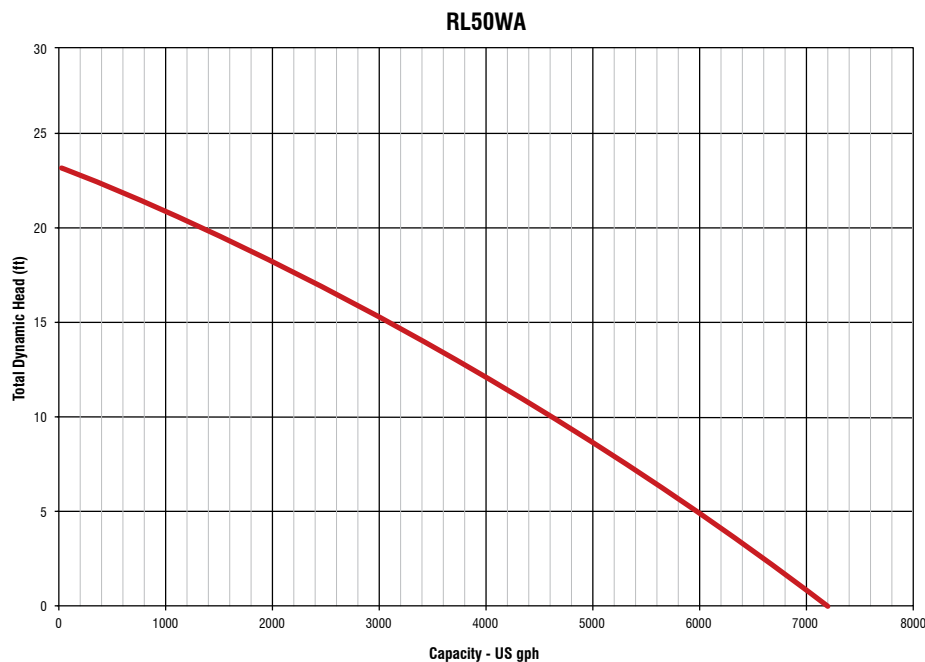

# HEAVY-DUTY CAST IRON EFFLUENT PUMP

## APPLICATIONS

Ideal for liquid effluent pumping applications, as well as light commercial applications with up to 11/16" diameter semi-solids.

## FEATURES & BENEFITS

- 1/3 hp 115 Volt thermal overload protected continuous duty motor
- Rugged cast iron construction
- Heavy-duty cast iron pump base and impeller
- Automatic piggyback float switch



Model	Item No.	UPC	HP	Amps	Volts	Discharge	Cord Length	Gallons Per Hour at Height					Shut-Off	Min. Basin Diameter
								5'	10'	15'	20'	25'		
RL31EA	620040	0 10121 12134 8	1/3	10.5	115	2" NPT	20'	6300	5400	4200	2700	900	28'	18" or more

## CARTON SPECIFICATIONS

Model	Length	Width	Height	Weight (lbs)	Carton Cubes (cu ft)	Pallet Quantity	Quantity per Layer	Layers per Pallet
RL31EA	9.75"	12.5"	21.5"	52	1.52	24	12	2

Heavy-Duty Cast Iron Effluent Pump

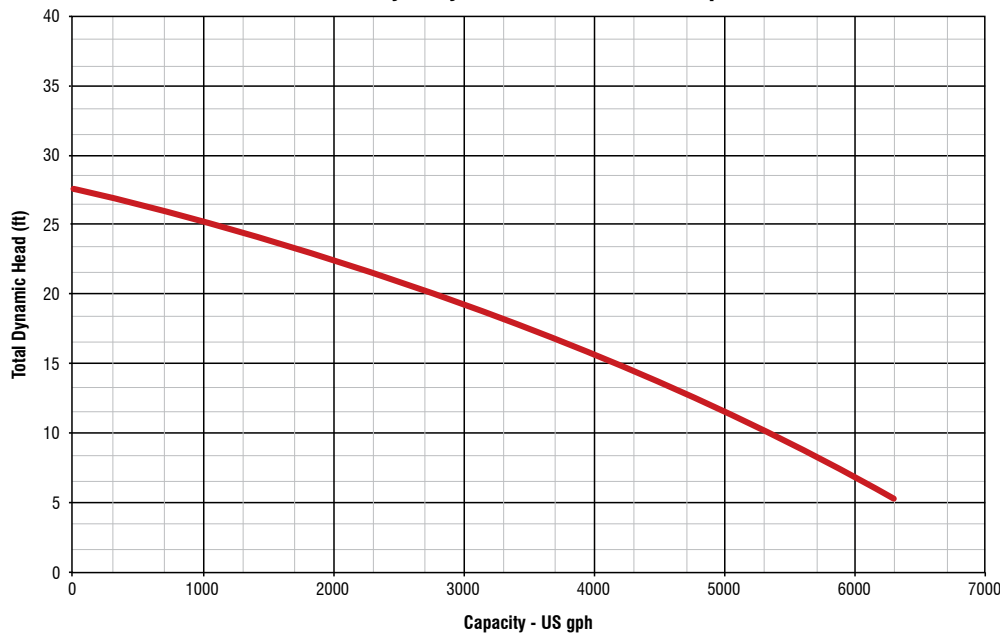

# CAST IRON SEWAGE PUMP

## APPLICATIONS

Ideal for high volume raw sewage removal applications

## FEATURES & BENEFITS

- Automatic submersible cast iron sewage pump
- PSC dual bearing motor with overload protection
- Capable of passing up to 2" diameter semi-solids
- Piggyback tethered float switch
- 10' power cord



Model	Item No.	UPC	HP	Volts	Amps	Discharge	Cord Length	Gallons Per Hour at Height					Shut-Off	On/Off Levels	Min. Basin Diameter
								0'	5'	10'	15'	20'			
RL-WC50TA	14942748	0 10121 14171 1	1/2	115	9	2" FNPT	10'	5600	4920	3720	1680	480	22'	On: 17.5" Off: 7.5"	18" or more

## CARTON SPECIFICATIONS

Model	Length	Width	Height	Weight (lbs)	Carton Cubes (cu ft)	Pallet Quantity	Quantity per Layer	Layers per Pallet
RL-WC50TA	8.5"	8.9"	18.4"	40	0.81	40	20	2

Cast Iron Sewage Pump

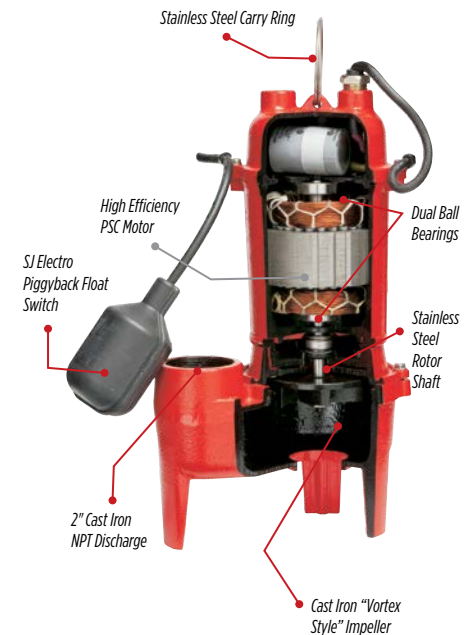
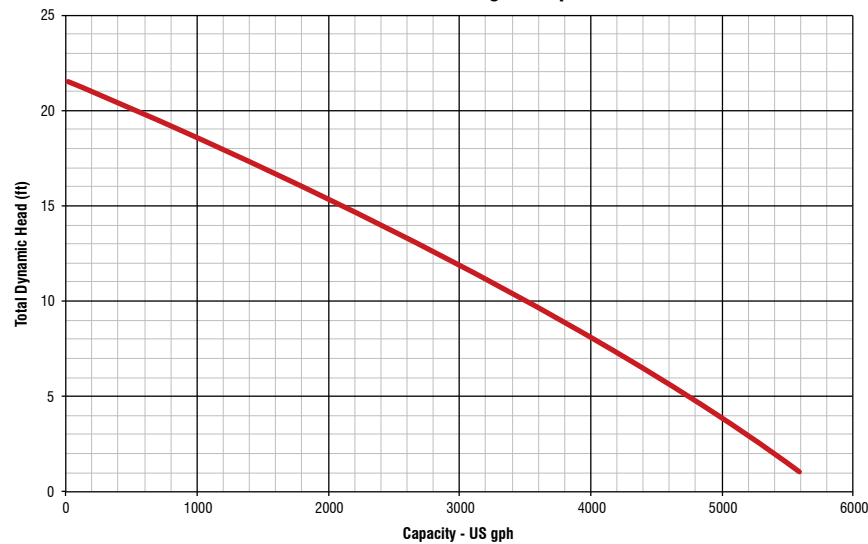

# PREMIUM CAST IRON SEWAGE PUMP

## APPLICATIONS

Ideal for high volume raw sewage removal applications.

## FEATURES & BENEFITS

- Automatic submersible cast iron sewage pump
- PSC dual bearing motor with overload protection
- Capable of passing up to 2" diameter semi-solids
- Piggyback tethered float switch



RL75WAM



RL52WAM



Model	Item No.	UPC	HP	Volts	Amps	Discharge	Cord Length	Gallons Per Hour at Height						Shut-Off	On/Off Levels	Min. Basin Diameter
								0'	5'	10'	15'	20'	25'			
RL52WAM	620051	0 10121 13855 1	1/2	115	11.4	2" FNPT	20'	9000	7200	6000	4500	960	-	22'	On: 16"-18" Off: 9"-11"	18" or more
RL75WAM	14942635	0 10121 14583 2	3/4	115	10.3	2" FNPT	10'	10500	9300	7620	5880	4200	1740	28'	On: 17.5" Off: 10.5"	18" or more

## CARTON SPECIFICATIONS

Model	Length	Width	Height	Weight (lbs)	Carton Cubes (cu ft)	Pallet Quantity	Quantity per Layer	Layers per Pallet
RL52WAM	11"	13.5"	16"	50	1.38	27	9	3
RL75WAM	11.75"	13.75"	15.5"	57	1.45	27	9	3

Premium Cast Iron Sewage Pump

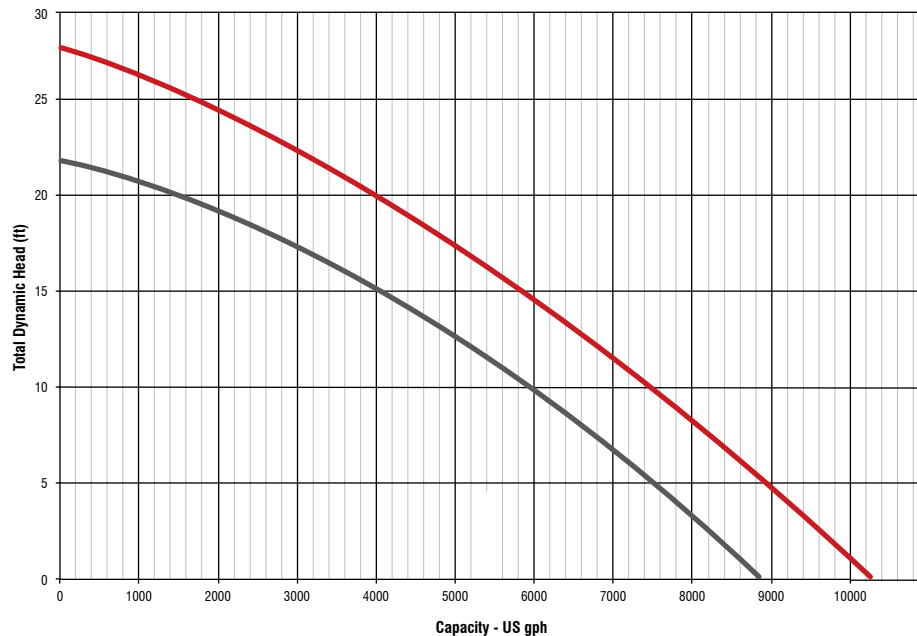

# SEWAGE BASIN SYSTEMS

## APPLICATIONS

Ideal for the collection and removal of raw sewage.

## FEATURES & BENEFITS

- Available with 18" x 30" or 24" x 24" polyethylene basin
- 2" full-flow sewage check valve
- Cover assembly and hardware
- Includes 1/2 hp sewage pump
- Discharge pipe, pump to basin cover
- Heavy-duty cast iron pump base and impeller
- Automatic piggyback float switch
- 18" x 30" basin comes with standard plastic check valve; 24" x 24" basin comes with cast iron check valve



Model	Item No.	UPC	Basin Dimensions	HP	Amps	Volts	Discharge	Cord Length	Gallons Per Hour at Height					Shut-Off	On/Off Levels	Assembly Required
									0'	5'	10'	15'	20'			
RL-WCS50TA	14942749	0 10121 14172 8	18" x 18" x 30"	1/2	9	115	2" FNPT	10'	5600	4920	3720	1680	480	22'	On: 17.5" Off: 7.5"	Yes
RL-WCS50TA-24	14942756	0 10121 15228 1	24" x 24" x 24"													

NOTE: Basin dimensions are approximate; they do not include the lip of the basin

## CARTON SPECIFICATIONS

Model	Length	Width	Height	Weight (lbs)	Carton Cubes (cu ft)	Pallet Quantity	Quantity per Layer	Layers per Pallet
RL-WCS50TA	18"	18"	36"	55	6.75	4	2	2
RL-WCS50TA-25	28.75"	28.75"	34.75"	76	16.62	1	1	1

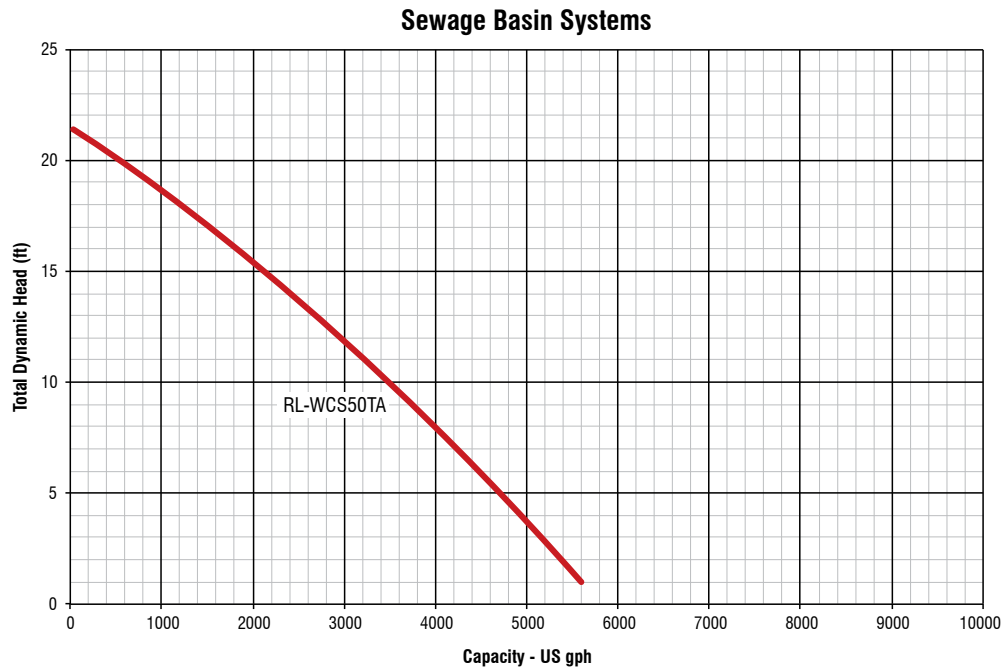

# THERMOPLASTIC UTILITY PUMPS

## APPLICATIONS

Ideal for general water transfer applications and household water removal in places like basements, aquariums, and window wells.

## FEATURES & BENEFITS

- Submersible 115 Volt utility pumps
- Reinforced engineered thermoplastic construction
- Screened bottom intake design
- Removes water to within 3/16" of surface
- Includes garden hose adapter



RL-MP25

RL-MP16

Model	Item No.	UPC	HP	Amps	Volts	Discharge	Intake	Cord Length	Gallons Per Hour at Height					Shut-Off
									0'	5'	10'	15'	20'	
RL-MP16	14942731	0 10121 14154 4	1/6	2	115	1" MNPT 3/4" GHT	Screened Bottom	8'	1300	1223	1068	864	550	26'
RL-MP25	14942732	0 10121 14155 1	1/4	2.5	115	1-1/4" MNPT 3/4" GHT	Screened Bottom	8'	2200	1920	1440	900	-	22'

## CARTON SPECIFICATIONS

Model	Length	Width	Height	Weight (lbs)	Carton Cubes (cu ft)	Pallet Quantity	Quantity per Layer	Layers per Pallet
RL-MP16	6.3"	6.3"	11.75"	7.25	0.27	168	42	4
RL-MP25	6.3"	6.3"	12"	7.5	0.28	168	42	4

Thermoplastic Utility Pump

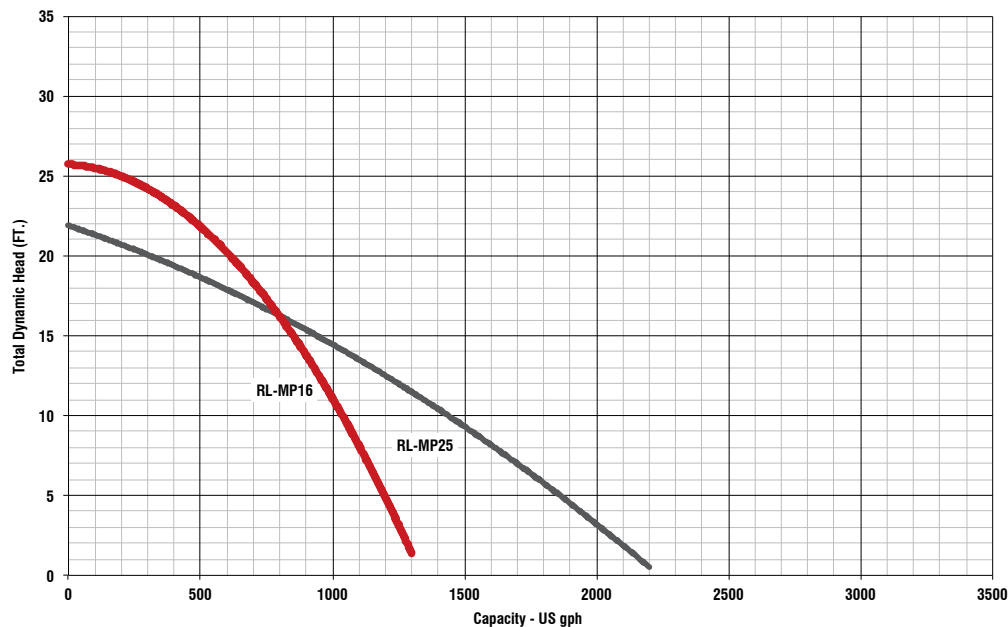

# ALUMINUM UTILITY PUMPS

## APPLICATIONS

Ideal for general water transfer applications and household water removal in places like basements, crawl spaces, rooftops, and window wells.

## FEATURES & BENEFITS

- Submersible 115 Volt utility pumps
- Corrosion-resistant aluminum casing for superior heat dissipation
- Lightweight portability
- Removes water to within 1/4" of surface
- 3/4" garden hose adapter included
- Oil-free motor design



RL-160U

RL-250U

Model	Item No.	UPC	HP	Amps	Volts	Discharge	Intake	Cord Length	Gallons Per Hour at Height					Shut-Off
									0'	5'	10'	15'	20'	
RL-160U	620109	0 10121 12595 7	1/6	2.1	115	3/4" FNPT	Screened Bottom	10'	1300	1200	780	360	-	19'
RL-250U	14942734	0 10121 14157 5	1/4	3.2	115	3/4" GHT	Screened Bottom	10'	1800	1380	1080	660	180	22'

## CARTON SPECIFICATIONS

Model	Length	Width	Height	Weight (lbs)	Carton Cubes (cu ft)	Master Pack Qty.
RL-160U	6"	6"	12"	9	0.25	6
RL-250U	6"	6"	12"	9.5	0.25	6

## MASTER PACK SPECIFICATIONS

Model	Length	Width	Height	Weight (lbs)	Carton Cubes (cu ft)	Pallet Quantity	Quantity per Layer	Layers per Pallet
RL-160U	18.75"	12.75"	13"	54	1.80	21 Master Packs	7 Master Packs	3
RL-250U	18.75"	12.75"	13"	57	1.80	21 Master Packs	7 Master Packs	3

Aluminum Utility Pumps

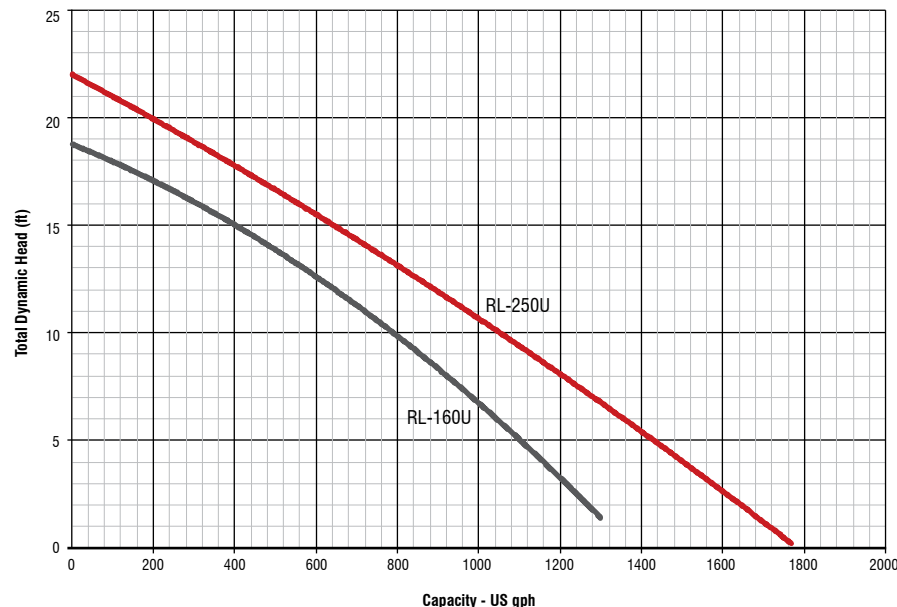

# AUTOMATIC UTILITY PUMP

## APPLICATIONS

Ideal for general water transfer applications and household water removal in places like basements, crawl spaces, rooftops, and other areas where automatic operation is required. This pump activates in three minute intervals to detect if water is present. If water is present, pump will continue to operate until water is removed.

## FEATURES & BENEFITS

- Automatic submersible 115 Volt utility pump
- Reinforced engineered thermoplastic construction
- Technologically advanced switch for automatic operation
- Checks for water every three minutes
- Screened bottom intake design removes water within 3/4" of surface or 1/4" of surface without the screen
- Includes garden hose adapter

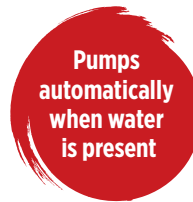

Model	Item No.	UPC	HP	Amps	Volts	Discharge	Intake	Cord Length	Gallons Per Hour at Height				Shut-Off
									0'	5'	10'	15'	
RL-MP25A	14942735	0 10121 14158 2	1/4	2.0	115	1-1/4" MNPT 3/4" GHT	Screened Bottom	10'	2200	1920	1440	900	22'

## CARTON SPECIFICATIONS

Model	Length	Width	Height	Weight (lbs)	Carton Cubes (cu ft)	Pallet Quantity	Quantity per Layer	Layers per Pallet
RL-MP25A	6.5"	6.25"	11.75"	7.5	0.28	168	42	4

Automatic Utility Pump

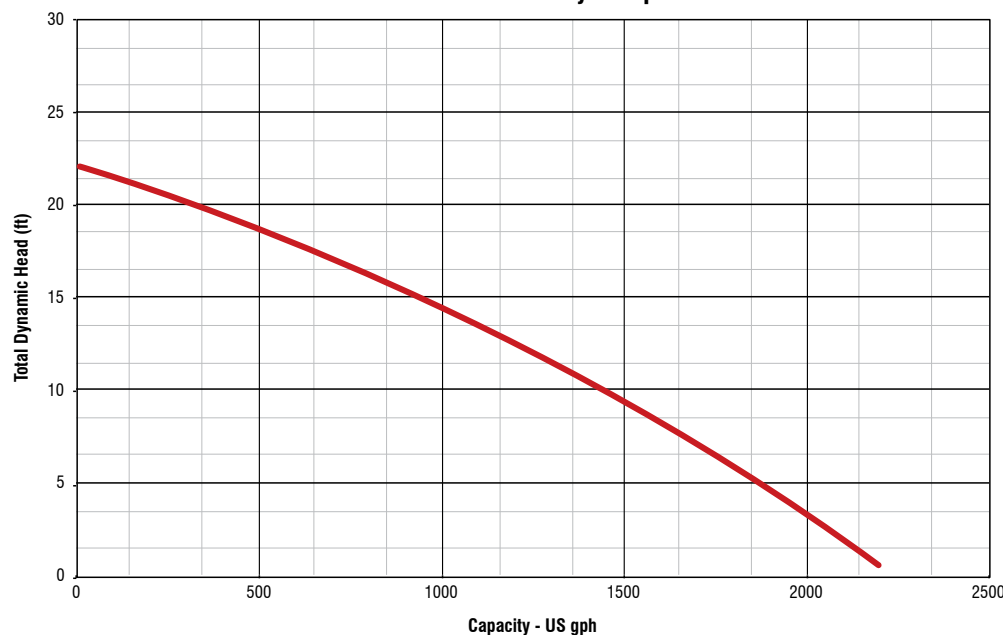

# UTILITY TRANSFER PUMPS

## APPLICATIONS

Ideal for draining hot water tanks, appliances, boat bilges and aquariums as well as water transfer applications where easy portability is required.

## FEATURES & BENEFITS

- Portable non-submersible transfer pumps
- Choice of 115 Volt or 12 Volt DC models
- Stainless steel construction
- Dual threaded intake and discharge fits both 3/4" male garden hose thread and 3/8" FNPT pipe connection
- Includes replacement impeller kit
- MPFVK115 includes hoses and suction attachment

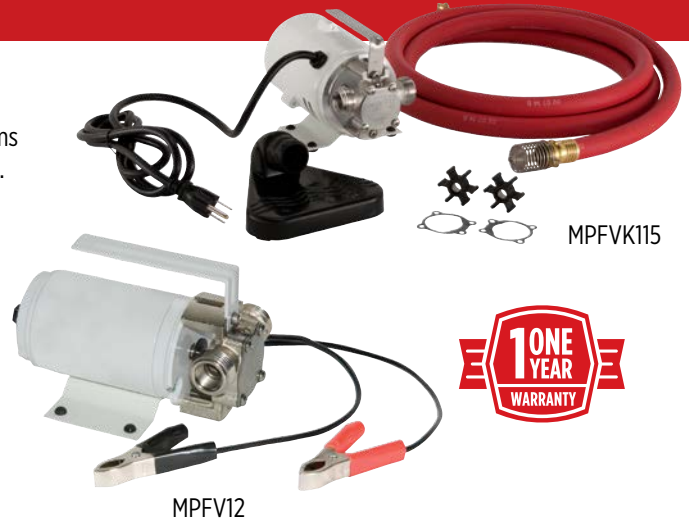

Model	Item No.	UPC	HP	Amps	Volts	Intake	Discharge	Cord Length	Gallons Per Hour at Height			
									0'	5'	10'	15'
MPFVK115	14942015	0 10121 00615 7	1/10	1.7	115	3/4" GHT, 3/8" FNPT	3/4" GHT, 3/8" FNPT	6'	365	330	300	280
MPFV12	14942004	0 10121 11803 4	1/10	7	12 V DC	3/4" GHT, 3/8" FNPT	3/4" GHT, 3/8" FNPT	6' leads	300	270	240	222

## CARTON SPECIFICATIONS

Model	Length	Width	Height	Weight (lbs)	Carton Cubes (cu ft)	Master Pack Quantity
MPFVK115	11"	12"	5"	8.6	0.38	2
MPFV12	4.75"	5.5"	7.5"	4.5	0.11	6

## MASTER PACK SPECIFICATIONS

Model	Length	Width	Height	Weight (lbs)	Carton Cubes (cu ft)	Pallet Quantity	Quantity per Layer	Layers per Pallet
MPFVK115	11"	10.75"	12.5"	17.2	0.86	36 Master Packs	12 Master Packs	3
MPFVK12	14.75"	11"	8.25"	26.7	0.77	36 Master Packs	12 Master Packs	3

Utility Transfer Pumps

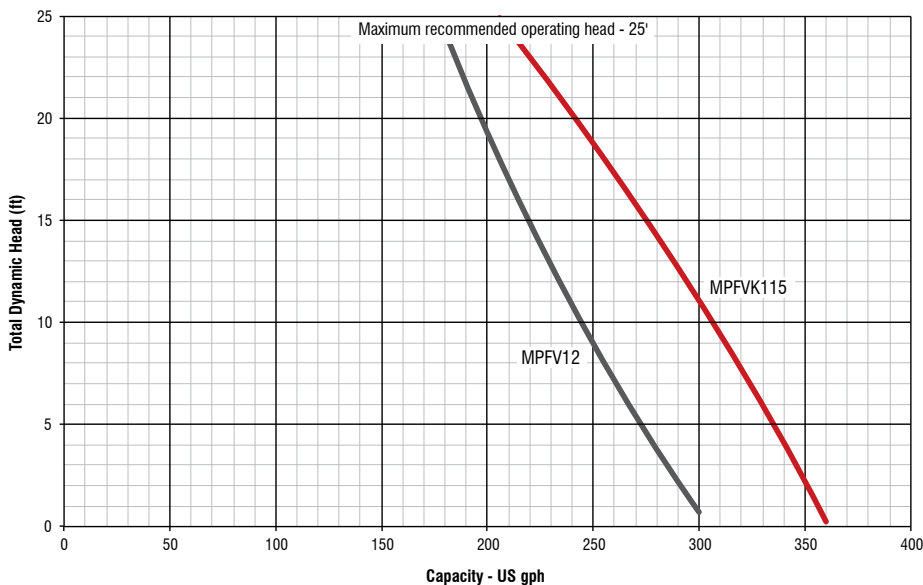

# CAMO MULTI-PURPOSE PUMP

## APPLICATIONS

Designed for the outdoor, hunting, camping, and fishing enthusiast, this pump is ideal for pumping out boat bilges and stock tanks, water transfer for washing an RV or ATV, and any other applications where easy portability is required. Equipped with a vehicle power adapter with 6' cord for use with any car, boat, truck, RV, or ATV. Requires a 15 A (or greater), 12 VDC vehicle outlet.



## FEATURES & BENEFITS

- Portable 12 Volt DC non-submersible transfer pump
- Stainless steel pump head and steel motor cover
- Convenient built-in carry handle
- Inlet and outlet easily connects to a garden hose
- Slip-resistant rubber feet to keep pump in place

Model	Item No.	UPC	HP	Volts	Amps	Intake/Discharge	Cord Length	Gallons Per Hour at Height					
								0'	5'	10'	15'	20'	25'
MPFV12CAMO	14942008	0 10121 14650 1	1/10	12 V DC	7	3/4" GHT 3/8" FNPT	6'	300	270	240	222	202	175

## CARTON SPECIFICATIONS

Model	Length	Width	Height	Weight (lbs)	Carton Cubes (cu ft)	Master Pack Quantity
MPFV12CAMO	4.75"	5.25"	7.33"	4.4	0.11	6

## MASTER PACK DIMENSIONS

Model	Length	Width	Height	Weight (lbs)	Carton Cubes (cu ft)	Pallet Quality	Quality per Layer	Layers per Pallet
MPFV12CAMO	14.75"	11"	8.25"	26.4	0.77	50 Master Packs	10 Master Packs	5

**MPFV12CAMO**

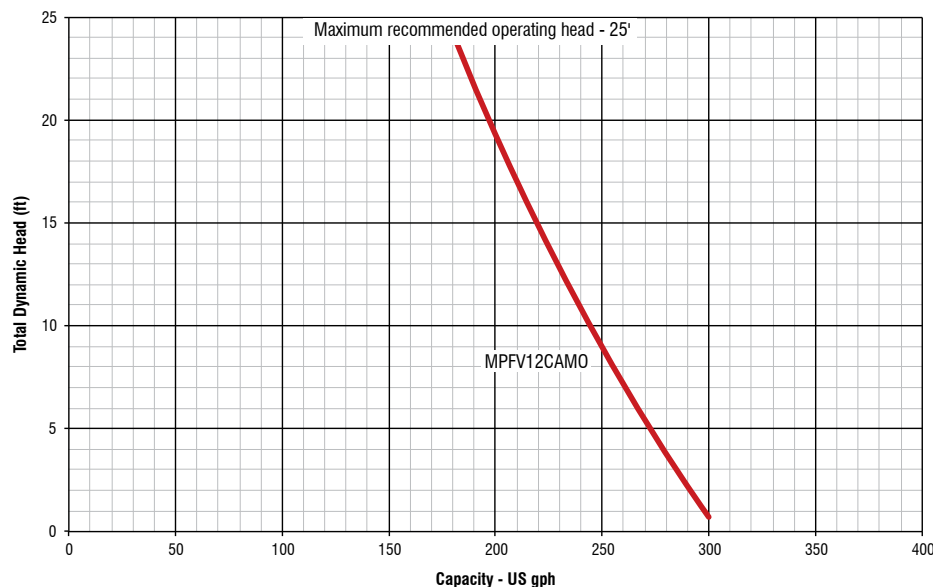

# MULTI-PURPOSE TRANSFER PUMP

## APPLICATIONS

Ideal for boosting household water pressure to wash vehicles and driveways and for use in other water transfer and removal applications.

## FEATURES & BENEFITS

- Non-submersible utility pump
- Heavy-duty cast iron construction
- Includes 3/4" brass garden hose adapters



Model	Item No.	UPC	HP	Amps	Volts	Intake	Discharge	Cord Length	Gallons Per Hour at Height					Shut-Off	
									0'	20'	40'	60'	80'		100'
MPTC	14942006	0 10121 11805 8	1/2	9	115	3/4" GHT	3/4" GHT	10'	1250	1152	912	648	372	90	105'

## CARTON SPECIFICATIONS

Model	Length	Width	Height	Weight (lbs)	Carton Cubes (cu ft)	Pallet Quantity	Quantity per Layer	Layers per Pallet
MPTC	6.6"	10.6"	10.5"	18	0.43	96	24	4

Multi-Purpose Transfer Pump

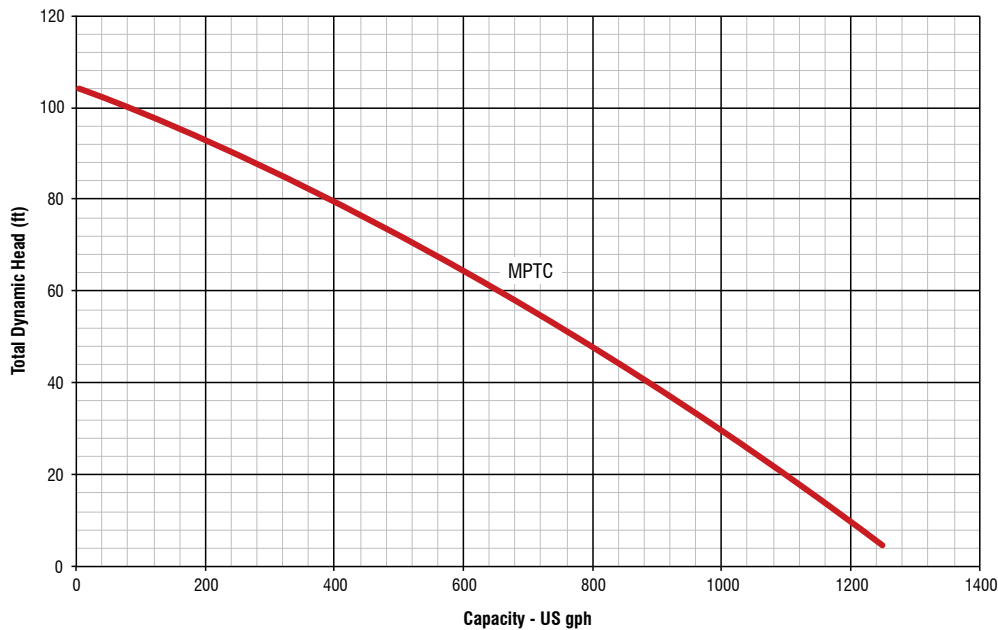

# DRILL POWERED TRANSFER PUMP

## APPLICATIONS

A cost-effective device that uses an ordinary drill to pump out water and other liquids. Ideal for draining sinks, dishwashers, water heaters, and aquariums as well as emergency pumping of shallow flooded areas.

## FEATURES & BENEFITS

- Multi-purpose drill pump
- Thermoplastic easy-to-prime construction for best pump performance and extended service life
- Connects to standard drill and garden hose—makes easy work out of household jobs



Model	Item No.	UPC	Length	Width	Height	Weight (lbs)	Max. Flow (GPH)
MPDP	14942003	0 10121 11802 7	2.5"	5"	7.75"	0.5	156*

\*Based on 2500 rpm

## MASTER PACK SPECIFICATIONS

Model	Length	Width	Height	Weight (lbs)	Carton Cubes (cu ft)	Master Pack Quantity	Pallet Quantity	Quantity per Layer	Layers per Pallet
MPDP	15.5"	9"	5.5"	3	0.44	6	104 Master Packs	13 Master Packs	8

# CONDENSATE REMOVAL PUMPS

## APPLICATIONS

Designed for removing condensation build-up from air handlers, boilers, and furnaces.

## FEATURES & BENEFITS

- Automatic operation
- High impact ABS construction
- Removable check valve
- Contains 3 inlet drain holes
- 15' and 20' models available



*Tubing included with C20ST*

Model	Warranty	Item No.	UPC	Amps	Volts	Discharge	Tubing	Cord Length	Gallons Per Hour at Height				Shut-Off
									0'	5'	10'	15'	
C20ST		14942601	0 10121 11807 2	1.5	115	3/8" Barb	Included	6'	82	70	52	25	20'

## CARTON SPECIFICATIONS

Model	Length	Width	Height	Weight (lbs)	Carton Cubes (cu ft)	Pallet Quantity	Quantity per Layer	Layers per Pallet
C20ST	7.25"	12.25"	7.35"	6.25	0.38	90	15	6

# HEAVY-DUTY SUBMERSIBLE UTILITY PUMP

## APPLICATIONS

Construction-grade, heavy-duty submersible utility pump designed for the most demanding applications such as dewatering construction sites, ponds, and ditches.

## FEATURES & BENEFITS

- Rugged construction with stainless steel motor housing and suction strainer
- Special urethane rubber impeller
- High efficiency, 115 V permanent split capacitor (PSC) motor, with thermal overload protection as well as upper and lower ball bearings for extended operation
- Double-seal system (silicon carbide primary mechanical seal with a carbon ceramic secondary seal)
- 20' extended length power cord



Model	Item No.	UPC	HP	Amps	Volts	Discharge	Intake	Cord Length	Gallons Per Hour at Height					Shut-Off
									4'	10'	20'	30'	37'	
RL50CON	14942722	0 10121 14585 6	1/2	5.0	115	2" MNPT	Screened Bottom	20'	3600	3240	2400	1200	0	37'

## CARTON SPECIFICATIONS

Model	Length	Width	Height	Weight (lbs)	Carton Cubes (cu ft)	Pallet Quantity	Quantity per Layer	Layers per Pallet
RL50CON	7.75"	9.25"	13.33"	26	0.55	75	25	3

**RL50CON**

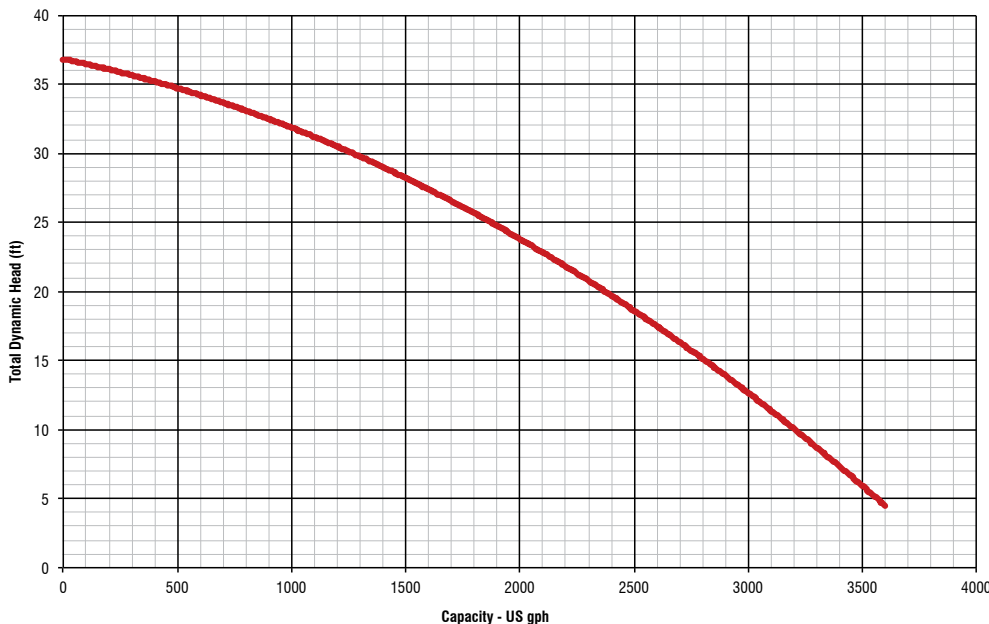

# ALUMINUM WATER TRANSFER PUMP

## APPLICATIONS

Ideal for general purpose use where portability is required such as water\* transfer and contractor dewatering applications.

## FEATURES & BENEFITS

- Durable cast iron semi-open style impeller
- Lightweight aluminum construction with base and handle for portability
- Easy to prime to 25'; no additional priming required after initial fill
- Built-in check valve
- EPA certified
- Includes 1" adapter



*\*This pump is designed for pumping water only.*

Model	Item No.	UPC	cc	Intake	Discharge	Suction Lift	Max. Head	Max. Flow (GPM)	Fuel Tank (qt)	Engine
2RLAG-1L	617031	0 10121 14500 9	79	1-1/2" MNPT	1-1/2" MNPT	25'	79'	60	1.7	Air Cooled 4 Stroke 79cc OHV

## CARTON SPECIFICATIONS

Model	Length	Width	Height	Weight (lbs)	Carton Cubes (cu ft)	Pallet Quantity	Quantity per Layer	Layers per Pallet
2RLAG-1L	14"	20.75"	17.75"	43	2.98	8	4	2

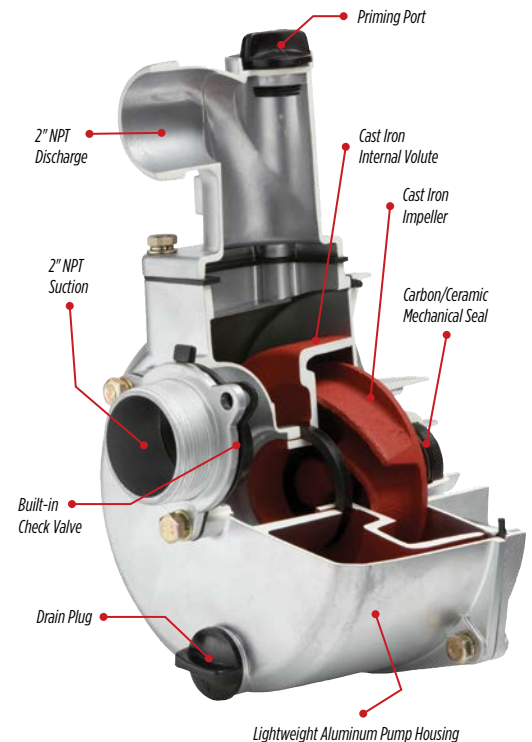
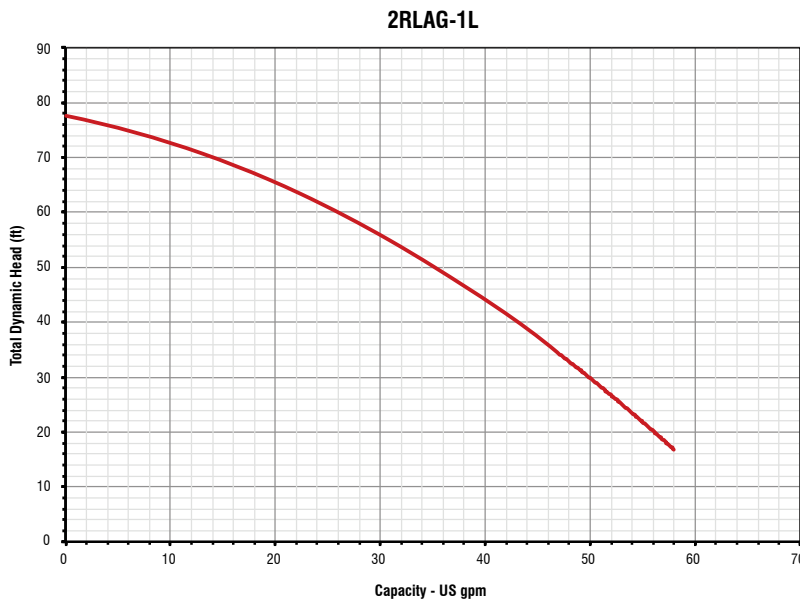

# ALUMINUM WATER TRANSFER PUMP

## APPLICATIONS

Ideal for general purpose use in high volume water\* transfer and contractor dewatering applications.

## FEATURES & BENEFITS

- Powered by commercial grade Honda GX120 engine
- Durable cast iron semi-open style impeller
- Lightweight aluminum outer casing includes heavy-duty roll frame
- Easy to prime to 25'; no additional priming required after initial fill
- Built-in check valve
- EPA certified

*\*This pump is designed for pumping water only.*

**POWERED by**  
**HONDA™**

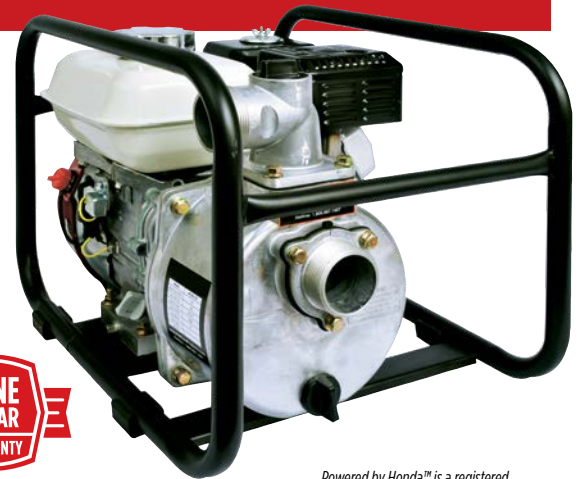

*Powered by Honda™ is a registered trademark of Honda Motor Co., Ltd.*

Model	Item No.	UPC	cc	Intake	Discharge	Suction Lift	Max. Head	Max. Flow (GPM)	Fuel Tank (qt)	Engine
4RLAG-2H	617053	0 10121 13751 6	118	2" MNPT	2" MNPT	25'	59'	143	2.1	Honda GX120 (118cc)

## CARTON SPECIFICATIONS

Model	Length	Width	Height	Weight (lbs)	Carton Cubes (cu ft)	Pallet Quantity	Quantity per Layer	Layers per Pallet
4RLAG-2H	15.25"	19.5"	15.25"	52	2.62	18	6	3

**4RLAG-2H**

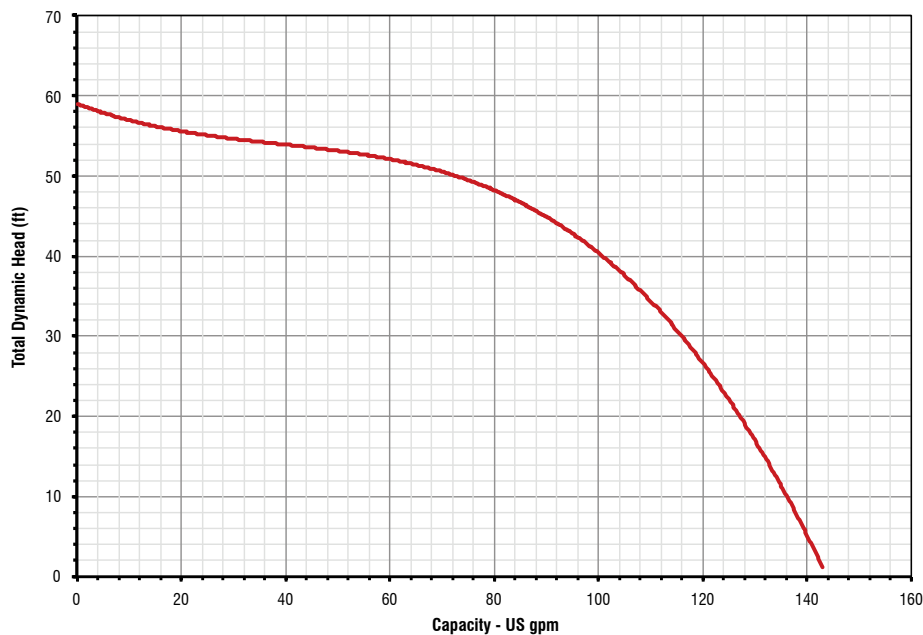

# ALUMINUM WATER TRANSFER PUMP

## APPLICATIONS

Ideal for general purpose use in high volume water\* transfer and contractor dewatering applications.

## FEATURES & BENEFITS

- Durable cast iron semi-open style impeller
- Lightweight aluminum outer casing includes heavy-duty roll frame
- Easy to prime to 25'; no additional priming required after initial fill
- Built-in check valve
- EPA certified



\*This pump is designed for pumping water only.

Model	Item No.	UPC	cc	Intake	Discharge	Suction Lift	Max. Head	Max. Flow (GPM)	Fuel Tank (qt)	Engine
5RLAG-2L	617033	0 10121 14502 3	179	2" MNPT	2" NPT	25'	92'	150	3.8	Air Cooled, 4 Stroke OHV (179cc)

## CARTON SPECIFICATIONS

Model	Length	Width	Height	Weight (lbs)	Carton Cubes (cu ft)	Pallet Quantity	Quantity per Layer	Layers per Pallet
5RLAG-2L	17.32"	19.69"	16.73"	62	3.75	8	4	2

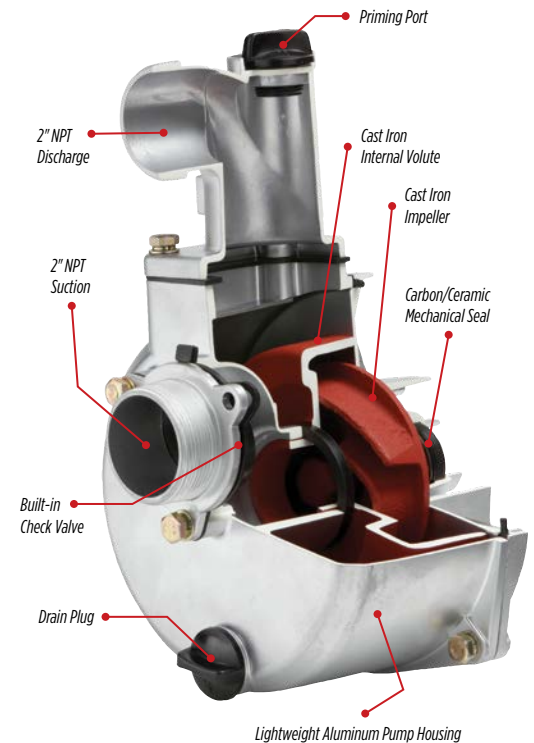
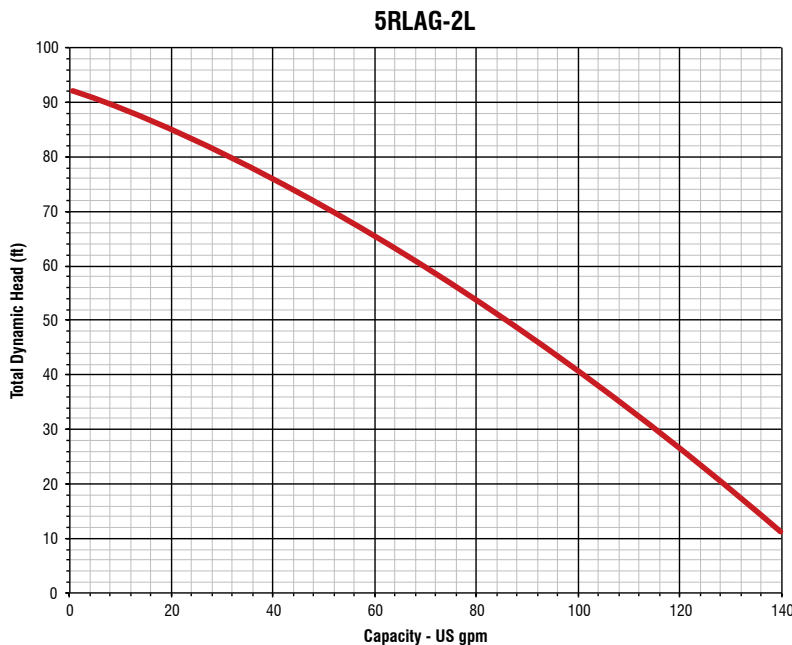

# ALUMINUM WATER TRANSFER PUMP KIT

## APPLICATIONS

Ideal for general purpose use where portability is required such as water\* transfer and contractor dewatering applications.



## FEATURES & BENEFITS

- Durable cast iron semi-open style impeller
- Lightweight aluminum outer casing includes heavy-duty roll frame
- Easy to prime to 25'; no additional priming required after initial fill
- Built-in check valve
- Includes 12' reinforced suction hose with steel suction strainer, 50' lay-flat discharge hose with attached couplings, and two 2" aluminum adapters for use with quick-connect couplers

*\*This pump is designed for pumping water only.*

Model	Item No.	UPC	cc	Intake	Discharge	Suction Lift	Max. Head	Max. Flow (GPM)	Fuel Tank (qt)	Engine
5RLAG-2LKIT	617030	0 10121 14612 9	179	2" NPT	2" NPT	25'	92'	150	3.8	Air Cooled, 4 Stroke OHV (179cc)

## CARTON SPECIFICATIONS

Model	Length	Width	Height	Weight (lbs)	Carton Cubes (cu ft)	Pallet Quantity	Quantity per Layer	Layers per Pallet
5RLAG-2LKIT	17.5"	27"	17.75"	85.9	4.85	4	2	2

5RLAG-2LKIT

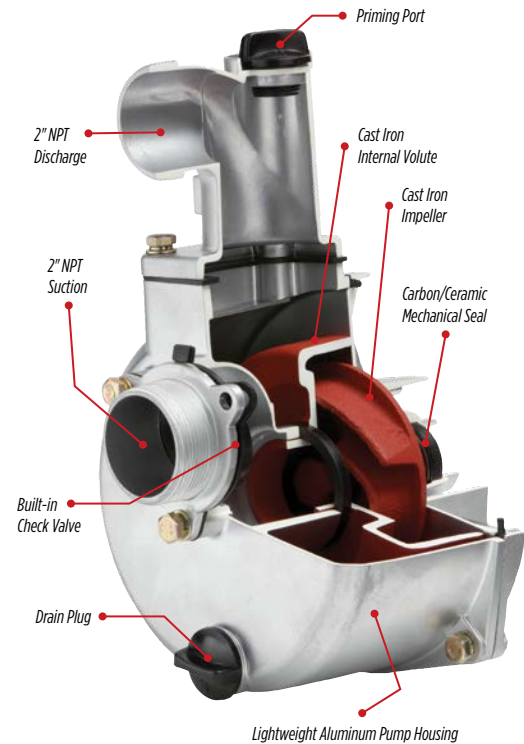
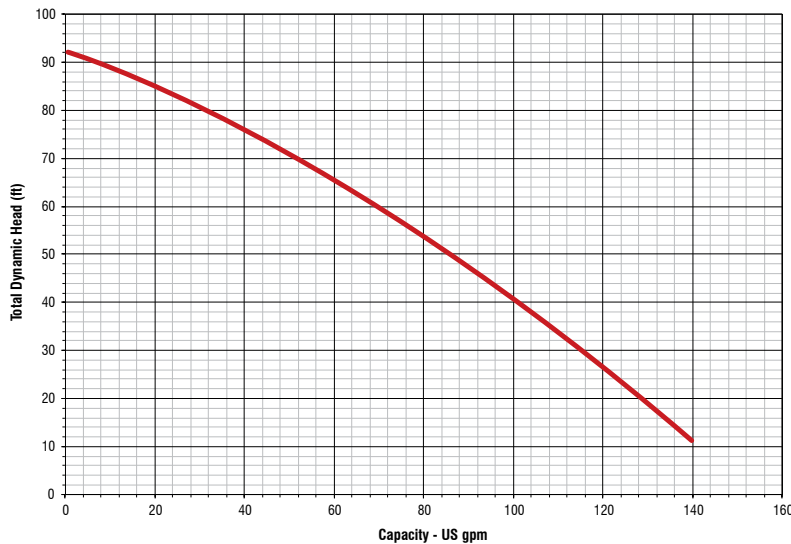

# ENGINE DRIVE CAST IRON TRANSFER PUMP

## APPLICATIONS

Ideal for liquid transfer including most agricultural chemicals\* and general dewatering where rugged portability is important.

## FEATURES & BENEFITS

- Heavy-duty cast iron pump casing
- Durable cast iron semi-open type impeller
- Stainless steel shaft sleeve and EPDM elastomer seal
- 2" NPT suction and discharge for convenient hook-up
- Easy to prime to 25'; no additional priming required after initial fill
- Handles most liquid agricultural chemicals
- Handles up to 5/8" solid debris

*\*Not to be used for applying driveway sealant.*

Powered by

**KOHLER**



*Powered by Kohler® is a registered trademark of Kohler Co.*

Model	Item No.	UPC	cc	Intake	Discharge	Suction Lift	Max. Head	Max. Flow (GPM)	Fuel Tank (qt)	Engine
5RLGF-8KRF	617032	0 10121 14501 6	196	2" FNPT	2" FNPT	25'	95'	170	3.8	Kohler, Air Cooled, 4 Stroke, OHV (196cc)

## CARTON SPECIFICATIONS

Model	Length	Width	Height	Weight (lbs)	Carton Cubes (cu ft)	Pallet Quantity	Quantity per Layer	Layers per Pallet
5RLGF-8KRF	17.5"	21"	18"	74	3.93	8	4	2

**5RLGF-8KRF**

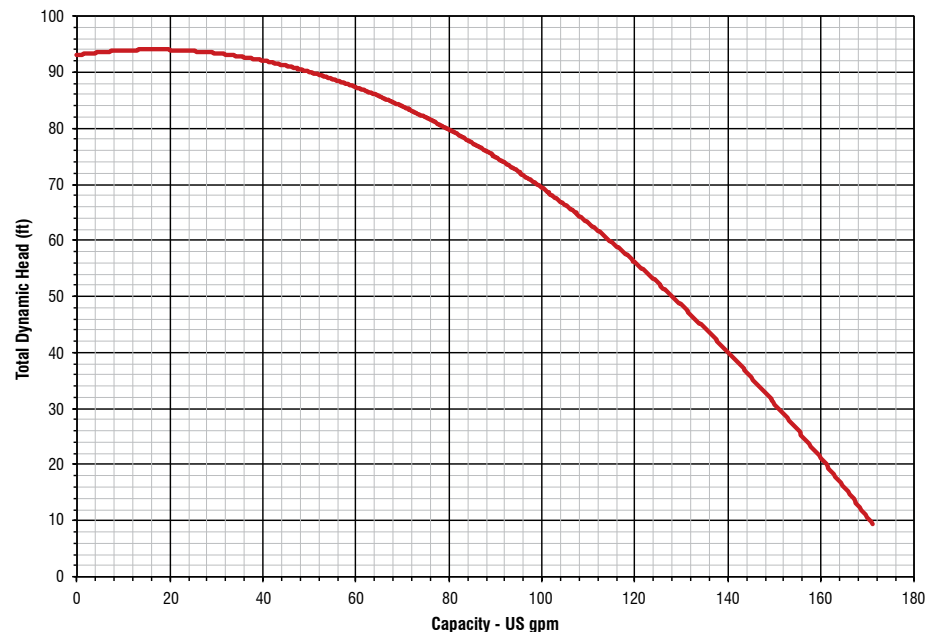

# THERMOPLASTIC AG CHEMICAL & TRANSFER PUMP

## APPLICATIONS

Ideal for sprayer applications such as liquid fertilizers and agricultural chemicals\*.

## FEATURES & BENEFITS

- Lightweight corrosion-resistant construction
- Easy to prime to 25'; no additional priming required after initial fill
- Integrated check valve and carry handle
- Rubber feet to dampen vibration
- EPA certified
- 3.8 quart fuel tank
- Carbon ceramic with EPDM elastomer seal



*\*Not to be used for applying driveway sealant.*

Model	Item No.	UPC	cc	Intake	Discharge	Suction Lift	Max. Height	Max. Flow (GPM)	Fuel Tank (qt)	Engine
6RLPG-2U	617070	0 10121 14086 8	212	2" FNPT	2" FNPT	25'	140'	195	3.8	4 Stroke OHV (212cc)

## CARTON SPECIFICATIONS

Model	Length	Width	Height	Weight (lbs)	Carton Cubes (cu ft)	Pallet Quantity	Quantity per Layer	Layers per Pallet
6RLPG-2U	20"	17.5"	16"	46.5	3.24	12	4	3

**6RLPG-2U**

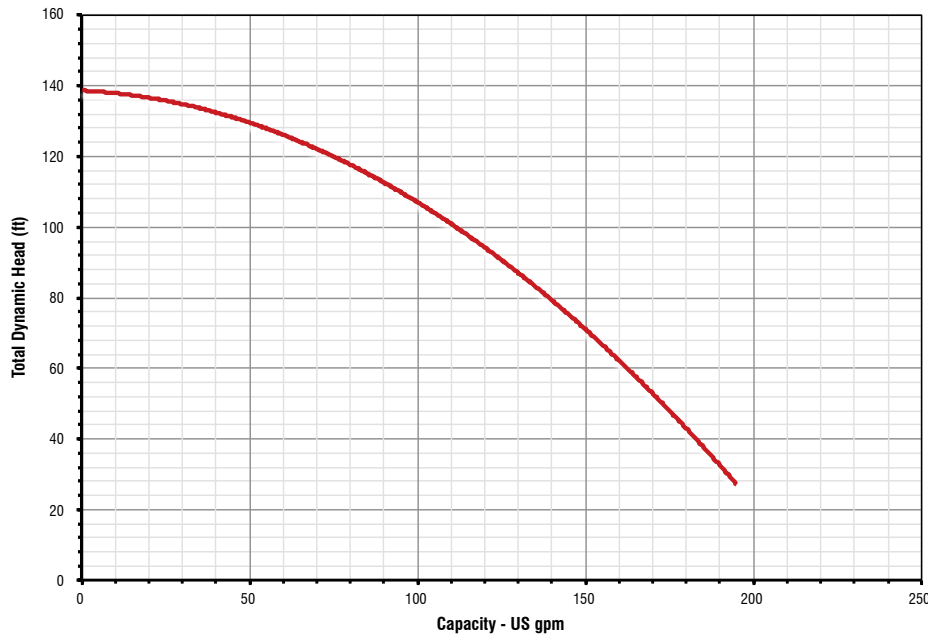

# THERMOPLASTIC AG CHEMICAL & TRANSFER PUMP

## APPLICATIONS

Ideal for sprayer applications such as liquid fertilizers and agricultural chemicals\*.

## FEATURES & BENEFITS

- Powered by Kohler 3000 Series 6.5 hp engine
- Lightweight corrosion-resistant construction
- Easy to prime to 25'; no additional priming required after initial fill
- Integrated check valve
- Includes heavy-duty roll frame
- EPA certified
- Carbon ceramic mechanical seal with EPDM elastomers

*\*Not to be used for applying driveway sealant.*

Powered by

**KOHLER**



*Powered by Kohler® is a registered trademark of Kohler Co.*



Model	Item No.	UPC	cc	Intake	Discharge	Suction Lift	Max. Height	Max. Flow (GPM)	Fuel Tank (qt)	Engine
6RLPG-2K	617071	0 10121 14413 2	196	2" FNPT	2" FNPT	25'	140'	195	3.8	Kohler 3000 Series (196cc)

## CARTON SPECIFICATIONS

Model	Length	Width	Height	Weight (lbs)	Carton Cubes (cu ft)	Pallet Quantity	Quantity per Layer	Layers per Pallet
6RLPG-2KRF	17.25"	20.5"	18"	47.5	3.68	8	4	2

**6RLPG-2KRF**

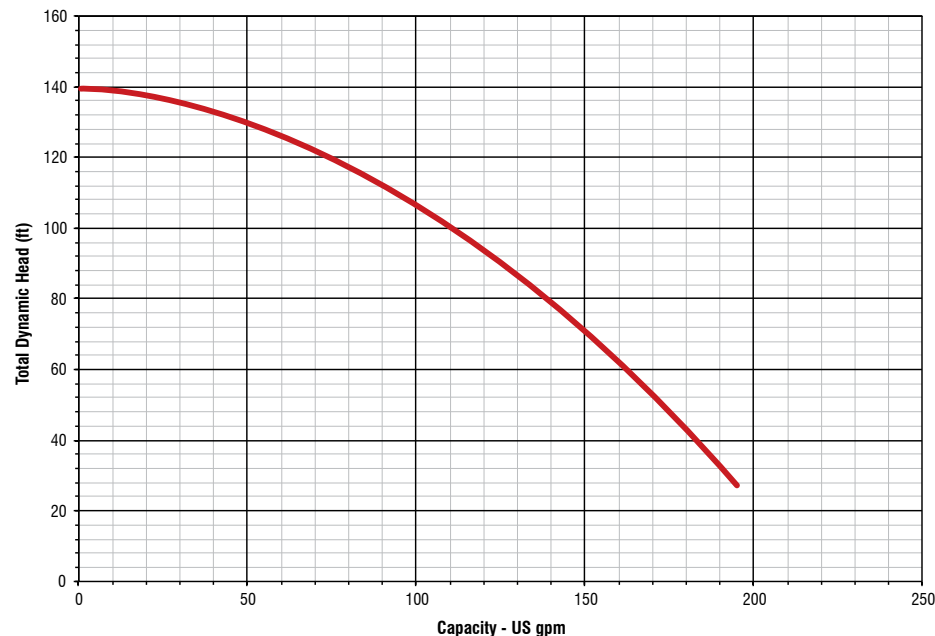

# ALUMINUM SEMI-TRASH PUMPS

## APPLICATIONS

Ideal for high volume water\* transfer and dewatering. Can handle liquid slurries including sand, pebbles, and suspended solids less than 1/2" in diameter.

## FEATURES & BENEFITS

- Durable cast iron semi-open style impeller
- Lightweight aluminum outer casing includes heavy-duty roll frame
- Wear-resistant silicon carbide mechanical seal
- Easy to prime to 25'; no additional priming required after initial fill
- Built-in check valve
- EPA certified

\*Not to be used for applying driveway sealant.



6RLAG-2LST

6RLAG-3LST



Model	Item No.	UPC	cc	Intake	Discharge	Suction Lift	Max. Head	Max. Flow (GPM)	Fuel Tank (qt)	Engine
6RLAG-2LST	617034	0 10121 14503 0	208	2" MNPT	2" MNPT	25'	92'	150	3.8	4 Stroke OHV (208cc)
6RLAG-3LST	617037	0 10121 14506 1	208	3" MNPT	3" MNPT	25'	85'	264	3.8	4 Stroke OHV (208cc)

## CARTON SPECIFICATIONS

Model	Length	Width	Height	Weight (lbs)	Carton Cubes (cu ft)	Pallet Quantity	Quantity per Layer	Layers per Pallet
6RLAG-2LST	17.5"	20"	16.5"	52	3.34	8	4	2
6RLAG-3LST	17.75"	22.75"	19"	66	4.44	8	4	2

Aluminum Semi-Trash Pumps

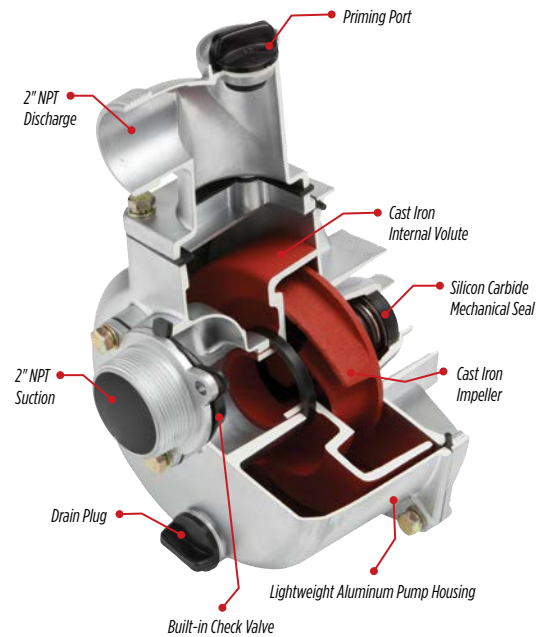
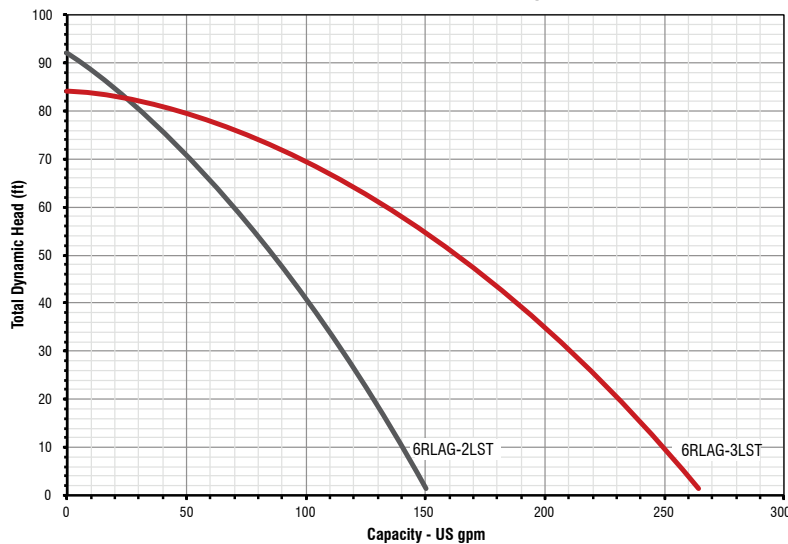

# ENGINE DRIVE SEMI-TRASH PUMP

## APPLICATIONS

Ideal for high volume water\* transfer and dewatering. Can handle liquid slurries including sand, pebbles, and suspended solids less than 1/2" in diameter.

## FEATURES & BENEFITS

- Powered by Commercial Grade Honda GX160 (163cc) engine
- Durable cast iron semi-open style impeller
- Lightweight aluminum outer casing includes heavy-duty roll frame
- Wear-resistant silicon carbide mechanical seal
- Easy to prime to 25'; no additional priming required after initial fill
- Built-in check valve
- EPA certified



*\*Not to be used for applying driveway sealant.*

*Powered by HONDA™ is a registered trademark of HONDA Motor Co., Ltd.*

**POWERED by HONDA™**

Model	Item No.	UPC	cc	Intake	Discharge	Suction Lift	Max. Head	Max. Flow (GPM)	Fuel Tank (qt)	Engine
6RLAG-3HST	617041	0 10121 14514 6	163	3" MNPT	3" MNPT	25'	85'	264	3.8 qt	Honda GX160

## CARTON SPECIFICATIONS

Model	Length	Width	Height	Weight (lbs)	Carton Cubes (cu ft)	Pallet Quantity	Quantity per Layer	Layers per Pallet
6RLAG-3HST	18"	22"	17"	68.15 lbs	3.896	8	4	2

**6RLAG-3HST**

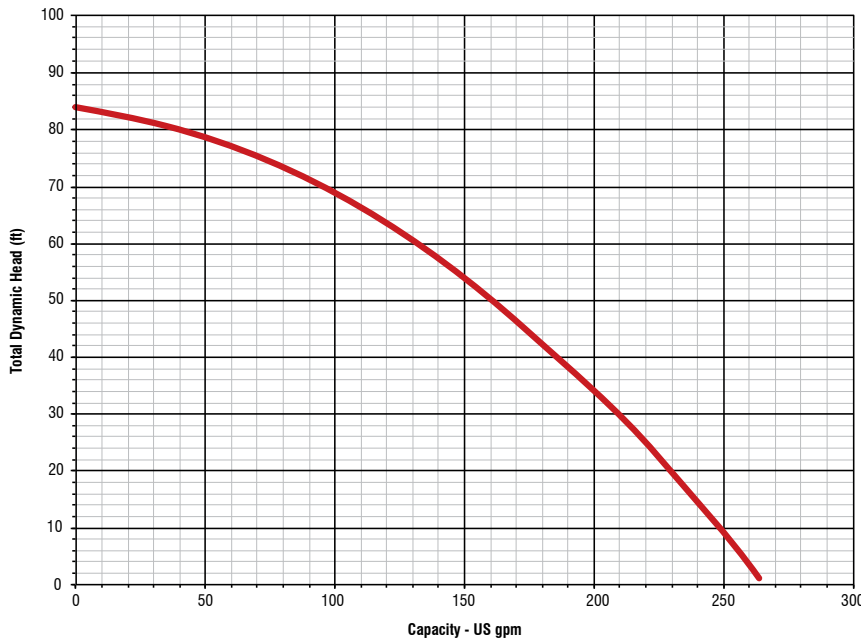

# ALUMINUM TRASH PUMP

## APPLICATIONS

Ideal for high volume water\* transfer and construction grade dewatering applications. Can handle liquid slurries containing sand, small rocks, and other debris less than 1-1/4" in diameter.

## FEATURES & BENEFITS

- Powered by 208cc 4 stroke air-cooled OHV engine
- Removable aluminum outer casing with cast iron inner volute and impeller for durability
- Silicon carbide seal for abrasion resistance and trash application
- Handles up to 1-1/4" solids
- Includes heavy-duty roll frame
- EPA certified



*\*Not to be used for applying driveway sealant.*

Model	Item No.	UPC	cc	Intake	Discharge	Suction Lift	Max. Height	Max. Flow (GPM)	Fuel Tank (qt)	Engine
6RLAG-3LTT	617038	0 10121 14507 8	208	3" NPT	3" NPT	25'	75'	285	3.8	Air Cooled, 4 Stroke OHV (208cc)

## CARTON SPECIFICATIONS

Model	Length	Width	Height	Weight (lbs)	Carton Cubes (cu ft)	Pallet Quantity	Quantity per Layer	Layers per Pallet
6RLAG-3LTT	19.5"	23"	18.5"	95	3.74	8	4	2

6RLAG-3LTT

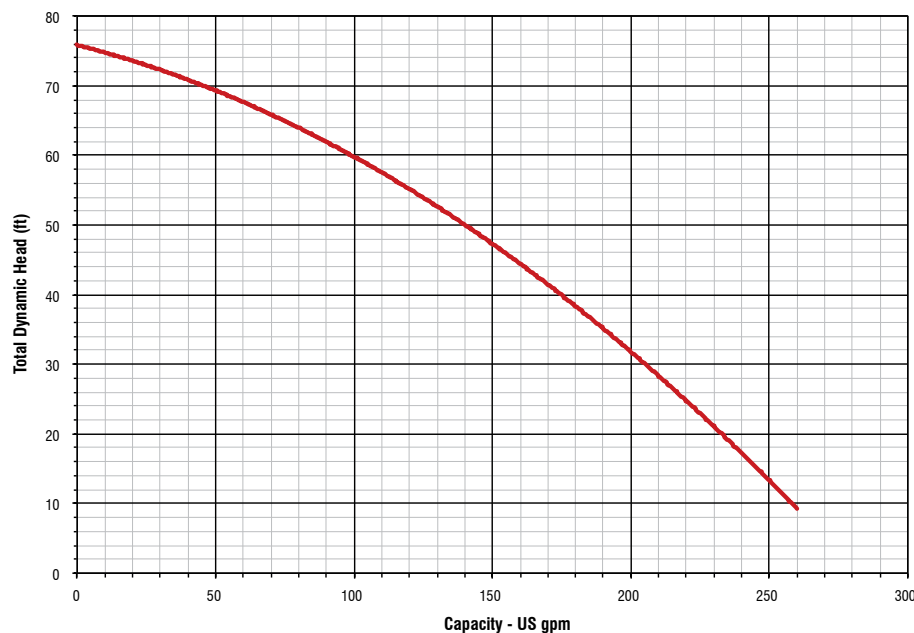

# ACCESSORIES

We offer a complete line of accessories and repair parts. For our most up-to-date list, please visit our website at [redlionproducts.com](http://redlionproducts.com). The accessories list is found under any product—just select Downloads and you'll see it at the bottom of the page.

## CLEANWATER ACCESSORIES



Pressure Switch



Pressure Gauge



Pump/Tank Mounting Base

## WASTEWATER ACCESSORIES



Tethered Float Switch



Vertical Float Switch



Discharge Hose Kit

## ENGINE DRIVE ACCESSORIES



617212



617201

# TRAINING PROGRAM

Training is what truly differentiates Red Lion from our competitors. Our team of factory-trained experts provides regional or in-store training at your location. Backed by years of experience and easy-to-use training materials, your staff will truly understand the products. All training is provided free of charge, and each participant receives valuable training material that they can refer to at any time.

Benefits of training sessions:

- Provides your staff with product knowledge
- Improves customer satisfaction
- Improves your image
- Matches the right product to the job
- Reduces warranty returns



# TROUBLESHOOTING GUIDE

## SHALLOW WELL JET PUMPS

1. Motor will not start:
  - No power to pressure switch due to blown fuses, open switches or loose connections.
  - Pump pressure switch not closed.
2. Pump fails to deliver water:
  - Pump not completely primed.
  - Suction lift is too great.
  - Foot valve is either not submerged, buried in mud or plugged.
  - Filtration cartridge (if used) needs changing or is not installed properly.
3. Pump loses prime:
  - Air leaks in suction line.
  - Well drawn down too far.
  - Faulty foot valve.
4. Pump delivers water but not at rated capacity:
  - Leaks in suction or discharge line.
  - Foot valve, suction line, impeller or nozzle are partially plugged.
  - Suction lift is greater than recommended.
  - Improper impeller rotation or low speed.
  - Venturi or diffuser is plugged.
  - Motor is wired for improper voltage.
  - Low line voltage at motor.
  - Motor does not come off starting windings (improper motor switch adjustment).
  - Filtration cartridge (if used) needs changing or is not installed properly.
5. Pump starts and stops too often:
  - Faulty air volume control.
  - Air leaks in tank above the water level.
  - Incorrect setting on pressure switch.
  - Tank is waterlogged or too small for application.

## CONVERTIBLE JET PUMPS

1. Motor will not start:
  - No power to pressure switch due to blown fuses, open switches or loose connections.
  - Pump pressure switch not closed.
2. Pump fails to deliver water:
  - Pump not completely primed.
  - Suction lift is too great.
  - Foot valve is either not submerged, buried in mud or plugged.
  - Restrictor valve is fully closed.
  - Filtration cartridge (if used) needs changing or is not installed properly.
3. Pump loses prime:
  - Air leaks in suction line.
  - Well drawn down too far and requires a tail-pipe.
  - Faulty foot valve.
4. Pump delivers water but not at rated capacity:
  - Leaks in suction or discharge line.
  - Foot valve, suction line, impeller or nozzle are partially plugged.
  - Suction lift is greater than recommended.
  - Improper setting of control valve on deep well units.
  - Improper impeller rotation or low speed.
  - Venturi or diffuser is plugged.
  - Motor is wired for improper voltage.
  - Low line voltage at motor.
  - Filtration cartridge (if used) needs changing or is not installed properly.
5. Pump starts and stops too often:
  - Air leaks in tank above the water level.
  - Incorrect setting on pressure switch.
  - Tank is waterlogged or incorrectly charged.
  - Foot valve leaks or is stuck open.

## SAND POINT APPLICATIONS

Trouble	Possible Solution
Pump noisy; output requirement exceeds available capacity.	Install/adjust valve on discharge to reduce output
Pump runs hot/won't shut off. Cannot build pressure due to lack of water at source.	Install low pressure cut-off switch to shut down pump prior to critical failure.
Changes in requirement not being met by current system (added bathroom, irrigations, etc.)	Increase pressure cut-off switch to offset peak period demand from insufficient source.

## RECOMMENDED MAXIMUM FLOW RATES

Pipe Diameter	Gallons Per Hour (gph)	Gallons Per Minute (gpm)
3/4"	750	12.5
1"	1000	17
1-1/4"	2100	35
1-1/2"	3000	50
2"	4800	80
3"	9000	150
4"	16000	267

# TROUBLESHOOTING GUIDE

## PRE-CHARGED PRESSURE TANKS

### Can I install my Red Lion diaphragm pressure tank on its side?

Side installations are acceptable up to the RL44 size. We do not recommend horizontal installations for any tanks larger than the RL44.

### What is the warranty on Red Lion tanks?

All Red Lion tanks carry a 5 year limited warranty from the date of manufacture on the original tank.

### My tank was just installed and the water has a funny taste – what should I do?

Flush the new tank by allowing water to flow through three or four pump cycles. If the taste continues, you should probably have the source water tested.

### Can I use chlorinated water with my Red Lion tank?

Of course. Red Lion tanks are designed with the knowledge that chlorine is often used to periodically treat a well.

### What is drawdown?

Drawdown refers to the amount of water that evacuates the tank before the pressure switch will activate the pump. Drawdown is affected by the pump, the size of the tank, and the pressure settings that govern your water system.

#### Tank System Operation

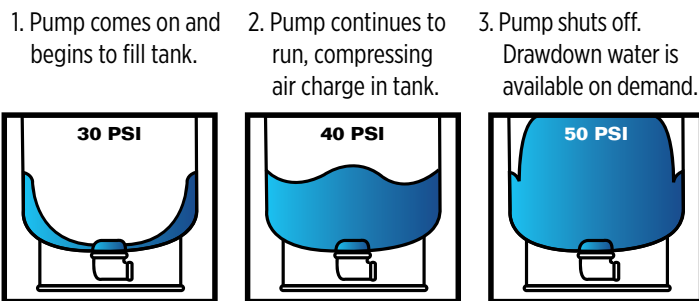

### What is pre-charge pressure?

Pre-charge pressure refers to the amount of air in psi that is pumped into a tank prior to installation (usually at the factory). Most tanks are provided with a 28 psi pre-charge (38 psi in the RL81 to RL119 sizes). The pre-charge is the “spring” that helps to create water pressure. As the diaphragm fills with water, it compresses the pre-charge. In a 30/50 system, the pump will continue to propel water into the tank until the pressure in the tank reaches 50 psi.

### How much pressure (pre-charge) should be in my tank?

Your tanks should be pressurized to 2 psi less than the cut-in pressure setting. For example, if your pressure settings are 30/50, then your cut-in pressure setting is 30 psi and your tank should have a 28 psi pre-charge.

### How do I check or change my pre-charge?

You must completely drain the tank to check its pre-charge. To do this, shut the power off to the pump and open (turn on) a faucet in the house. This will drain the tank and not allow it to refill. On the top of the tank you will find an air valve (similar to the air valve on your tires)—use a tire pressure gauge to check the air pressure.

# TROUBLESHOOTING GUIDE

## 4" SUBMERSIBLE WELL PUMPS

Trouble	Possible Cause	Corrective Action
Motor will not start but does not blow fuses.  <b>WARNING!</b> Hazardous voltage. Can shock, burn or cause death. Qualified electricians should work on electrical service.	No voltage to motor.	With a voltmeter check: 1) fuse box to make sure full voltage is available; 2) pressure switch terminals to make sure pressure switch is passing voltage correctly; and 3) terminal strips in pump control box or disconnect switch box to make sure voltage is available there. On 1-1/2 through 3 hp: push red overload reset button(s) on the bottom of the control center.
	Cable splices or motor windings may be grounded, shorted or open-circuited.	Consult certified electrician or service technician. Do not attempt to disassemble pump or motor.
	Faulty pressure switch.	Check pressure switch; replace if necessary.
	3-wire only; open circuit in pump control box; faulty connections; faulty wires.	Examine all connections and wires; examine terminal strips in the control center (3-wire only); repair if necessary.
Pressure switch fails to shut off pump.	3-wire only; cable leads improperly connected in the control center.	Check wiring diagram on control center panel and color coding of drop cable.
	Voltage is too low; motor will run slowly, causing low discharge pressure (head) and high operating current draw.	Have a certified electrician verify voltage at the electrical disconnect box (2-wire) or control center (3-wire) while the pump is operating. If the voltage is low, the power company may need to raise it or installation may require larger wire. Discuss this with the power company or a certified electrician. Check voltage with a recording meter if trouble reoccurs.
	Faulty pressure switch.	Replace switch.
	Drop pipe is leaking.	Raise one length at a time until the leak is found. When water stands in the pipe, there is no leak below this point.
Fuses blow or overload protector trips when motor is running.	Water level in the well may become too low when pump is running.	Lower the pump further into the well, but make sure it is at least five feet from the bottom of the well. Install a control valve in the discharge pipe between the pump and pressure tank. Use the control valve to restrict the flow until the discharge rate does not exceed well recovery rate. <b>WARNING!</b> To prevent the possibility of dangerously high pressure, install a relief valve in the discharge pipe between the pump and flow restriction valve. The relief valve must be capable of passing full pump flow at 75 psi.
	Low or high voltage.	While the motor is running, voltage should not exceed plus 5% or minus 5% of rated voltage shown on motor nameplate. Plus 3% or minus 3% in Canada. Call your power company to adjust line voltage if it is not within these limits.
	Wire size is too small. Improperly connected in the pump control box.	See cable selection guide in the technical data section and make sure the wire sizes match specifications in table.
	Cable splices or motor windings may be grounded, shorted or open-circuited.	Consult certified electrician or a service technician to determine if this is the cause of the problem or not. Do not attempt to disassemble the pump or motor.
Air or milky water discharges from your faucets.	3-wire only; high ambient (atmospheric) temperature.	Make sure the pump control box is installed out of direct sunlight.
	3-wire only; pump control box wrong horsepower or voltage for installation.	Compare horsepower and voltage rating of motor (from motor nameplate) with those of the pump control box (from pump control box nameplate). These numbers must match.
	Well water may be gaseous.	If your well is naturally gaseous and your system has a standard tank, remove the bleeder orifices and plug the tees. If the condition is serious, check with a certified well professional.

# TROUBLESHOOTING GUIDE

## 4" SUBMERSIBLE WELL PUMPS

Trouble	Possible Cause	Corrective Action
Your pump delivers little or no water.	Water level in a low-producing well drops too low while pump is operating, causing it to air lock (resulting in loss of prime and possibly serious damage to the pump).	Lower the pump further into the well, but make sure it is at least five feet from the bottom of the well. Install a control valve in the discharge pipe between the pump and pressure tank. Use the control valve to restrict the flow until the discharge rate does not exceed well recovery rate. <b>WARNING!</b> To prevent the possibility of dangerously high pressure, install a relief valve in the discharge pipe between the pump and flow restriction valve. Relief valve must be capable of passing full pump flow at 75 psi.
	Intake screen is partially plugged.	Lime or other matter in the water may build up on screen. Pull pump and clean screen.
	Check valve(s) may be stuck.	Make sure that the built-in check valve in the pump and any check valves in the discharge line are free to open properly.
	Voltage is too low; the motor runs slowly, causing low discharge pressure (head) and high operating current draw.	Have a certified electrician verify voltage at the electrical disconnect box (2-wire) or control center (3-wire) while the pump is operating. If the voltage is low, the power company may need to raise it or installation may require larger wire. Discuss this with the power company or a certified electrician. Check voltage with a recording meter if trouble reoccurs.
	Filtration cartridge (if used) needs changing or is not installed properly.	Change filtration cartridge or ensure plastic wrapping is removed.
Pump starts too frequently.	Leak in the pressure tank or plumbing.	Check all connections with soap suds for air leaks. Fix any leaks you find. Check the plumbing for water leaks. Fix any leaks you find.
	Pressure switch is defective or out of adjustment.	If necessary, replace switch.
	Check valve is leaking.	Inspect valves and replace if necessary.
	Tank is waterlogged.	Captive air tanks: Check the tank for leaks; correct if possible. Pre-charge tanks to 18 psi with a 20-40 psi switch, 28 psi for a 30-50 switch, 38 psi for a 40-60 psi switch, etc. Standard tanks: Check the tank for leaks; correct if possible. Check bleeder orifices and clean bleeders; replace if necessary.
	Drop pipe leaking.	Raise one length of pipe at a time until the leak is found. When water stands in the pipe there is no leak below this point.
	Pressure switch is too far from the tank.	Move the pressure switch to within one foot of the tank.
Fuses blow or overload protector trips when motor starts.	Low or high voltage.	While the motor is running, voltage should not exceed plus 5% or minus 5% of rated voltage shown on motor nameplate. Plus 3% or minus 3% in Canada. Call your power company to adjust line voltage if it is not within these limits.
	Wire size is too small. Improperly connected in the pump control box.	See cable selection guide in the technical data section and make sure the wire sizes match specifications in table.
	Cable splices or motor windings may be grounded, shorted or open-circuited.	Consult certified electrician or a service technician to determine if this is the cause of the problem or not. Do not attempt to disassemble the pump or motor.
	3-wire only; cable leads may be improperly connected in pump control box, pressure switch or fused disconnect switch.	Check wiring diagram on pump control box and color coding of drop cable.
	3-wire only; there may be a broken wire in the pump control box.	Employ a certified electrician to examine all connections and wiring in control panel. If necessary, repair them.
	3-wire only; starting or running capacitor in control box may be defective or vented (blown out).	Inspect capacitors. Employ a certified electrician to check capacitors and replace them if necessary. <b>WARNING!</b> Hazardous voltage; can shock, burn or cause death. Capacitors may still carry voltage charges even after being disconnected from wiring. Have them checked by a certified electrician.

# TROUBLESHOOTING GUIDE

## SUBMERSIBLE UTILITY & SUMP PUMPS

Trouble	Possible Cause	Corrective Action
Motor does not run.	Blown fuse.	Replace fuse.
	Tripped circuit.	Reset.
	Disconnected plug.	Reinstall pump.
	Corroded plug.	Clean prongs.
	Tripped overload.	Allow pump to cool, investigate cause (i.e. jammed impeller).
	Defective switch.	Replace switch.
	Defective motor.	Replace pump.
	Float obstructed.	Check for freedom of movement. Ensure switch isn't touching wall of basin or pit.
Motor hums but flow reduced or none at all.	Impeller jammed.	Remove bottom plate and clean.
	Plugged check valve.	Remove valve, clean or replace.
	Partially blocked inlet.	Clean inlet.
	Line leak.	Repair line.
	Worn impeller.	Replace pump/repair.
	Defective motor.	Replace pump.
Pump runs continuously.	Plugged inlet.	Clean inlet.
	Defective switch.	Replace switch.
	Float obstruction.	Adjust position of pump.
	Plugged check valve.	Remove valve, clean or replace.

**CAUTION**

A plugged pump inlet can be mistaken for a faulty switch. If the pump runs continuously or for extended periods of time between turning off, first check for a partially plugged inlet.

**RL-S CAST IRON SURFACE EFFLUENT PUMP & RL-50 HEAVY-DUTY MULTI-PURPOSE TRANSFER PUMP**

1. Pump fails to prime or primes slowly:

- Leaks in suction line.
- Loose gasket connection due to shrinkage of the gasket.
- Collapsed or clogged suction line.
- Not enough water in the casing for priming.
- Suction lift is too great.

2. Reduced pressure or capacity:

- Partially collapsed or clogged suction line.
- Clogged impeller.
- Leaks in the suction line.
- Strainer or end suction hose is not properly submerged.
- Suction line is improperly installed, resulting in air pockets in the suction line.
- Suction lift is too great (the greater the suction lift, the lower the capacity and pressure).
- Worn parts, such as the impeller or the pump casing.

# TROUBLESHOOTING GUIDE

## RJSE SPRINKLER UTILITY PUMPS

1. Motor will not start:
  - No power to pressure switch due to blown fuses, open switches or loose connections.
  - Pump pressure switch not closed.
2. Pump fails to deliver water:
  - Pump not completely primed.
  - Suction lift is too great.
  - Foot valve is either not submerged, buried in mud or plugged.
  - Convertible jet only; restrictor valve is fully closed.
3. Pump loses prime:
  - Air leaks in suction line.
  - Well drawn down too far.
4. Pump delivers water but not at rated capacity:
  - Faulty foot valve.
  - Leaks in suction or discharge line.
  - Foot valve, suction line, impeller or nozzle are partially plugged.
  - Suction lift is greater than recommended.
  - Improper impeller rotation or low speed.
  - Venturi or diffuser is plugged.
  - Motor is wired for improper voltage.
  - Motor does not come off starting windings (improper motor switch adjustment).

## RLSP/RLHE SPRINKLER PUMPS

Trouble	Possible Cause	Corrective Action
Failure to pump.	Pump not properly primed.	Make sure pump casing and suction line are full of water. See priming instructions.
	Speed too low.	Employ a certified electrician to check voltage at motor terminals and at meter when pump is operating. If low, refer to wiring instructions or check with your power company. Check loose connections. <b>WARNING!</b> All wiring, electrical connections, and system grounding must comply with the National Electrical Code (NEC) and with any local codes and ordinances.
	Total head is greater than what pump can handle.	Reduce total head or use a higher head pump.
	Suction lift is too great.	Locate pump closer to source of water. Make sure suction piping is large enough.
Capacity and/or head is reduced.	Air pockets or leaks in suction line.	Check suction piping.
	Clogged impeller.	Remove impeller and clean.
	Strainer is too small or clogged.	Use larger strainer or clean.
	Insufficient submergence of suction line.	Add lengths of suction pipe to keep submerged end well below the water surface, or move the pump closer to source of liquid.
	Excessive suction lift.	If caused by suction pipe friction, enlarge piping. Otherwise, move pump closer to water level.
	Total head is greater than what pump can handle.	Reduce total head or use a higher head pump.
Pump loses prime.	Excessively worn impeller.	Replace impeller.
	Air leaks in suction line.	Check suction piping.
	Excessive lift and operating too near shut-off point.	Move pump nearer water level.
Mechanical troubles and noise.	Water level drops while pumping, uncovering suction piping.	Check water supply. Add length of pipe to suction to keep submerged end under water, or move the pump closer to source of liquid.
	Bent shaft and/or damaged bearings.	Take motor to authorized motor repair shop.
	Suction and/or discharge piping not properly supported and anchored.	See that all piping is supported to relieve strain on pump assembly.

# TROUBLESHOOTING GUIDE

## ENGINE DRIVE TRANSFER PUMPS

Trouble	Possible Cause	Corrective Action
Pump will not pump.	Air leak in suction line.	Make sure suction hose is double clamped at joints, clamps are tight, fittings have thread compound and are tight, with no nicks or cuts in hose.
	The suction and/or discharge line(s) may be blocked, or the valve(s) are closed, faulty and/or blocked.	Check to see that the lines and valves are in good working order.
	The end of the suction line is not submerged.	Increase its length, or move pump closer to source of liquid.
	Total head is greater than what pump can handle.	Reduce total head or use a higher head pump.
Pump will not prime.	Excessive suction lift (*1)	Move the pump closer to liquid source.
Priming takes a long time.	Suction line is quite long.	See priming instructions in owner's manual.
	Air pockets or leaks in the suction line.	Check the line for loose connections.
Pump does not perform as well as it should.	Flow is restricted due to: a. Debris build-up. b. Faulty or semi-open valve(s). c. Pipe or hose used is smaller than the thread sizes on the pump.	a. Clean the lines and fittings. b. Check to see that the valves are in good working order. c. Increase the size of hose or pipe to reduce friction losses.
	Insufficient submergence of the end of the suction line.	Add lengths of suction pipe to keep submerged end well below the water surface, or move the pump closer to source of liquid.
	Excessively worn impeller (*2).	Replace impeller.
	Seal is damaged (*3). Liquid will be leaking through the middle of the adapter.	Replace the seal.
	Air pockets or leaks in the suction line.	Check the line for loose connections.
	Clogged impeller.	Remove casing to clean out.
Pump loses prime.	Engine throttle is in SLOW position.	Move throttle to FAST position.
	Water level drops while pumping, uncovering suction piping.	Check water supply. Add length of pipe to suction to keep submerged end under water, or move the pump closer to source of liquid.
Pump will not start.	No fuel.	Allow engine to cool for 2 minutes, then fill fuel tank.
	Faulty spark plug.	Replace spark plug.
	Fuel valve lever is in the OFF position.	Turn the fuel valve lever to the ON position.
Pump starts, but runs roughly.	Ignition switch is in the OFF position.	Turn the ignition switch to the ON position.
	Choke is in the wrong position.	Slide choke lever to the RUN position.
	Choke is in the wrong position.	Slide choke lever to the RUN position.
	Spark plug wire is loose.	Attach wire to spark plug secure.
Pump shuts down during operation.	Faulty spark plug.	Replace spark plug.
	Fuel is contaminated (water, debris, etc.).	Allow engine to cool for 2 minutes, then drain fuel tank and carburetor. Fill tank with fresh fuel.

1. Pump fails to prime or primes slowly:

- Size and length of pipe.
- Pipe fitting.
- Elevation above sea level.

Including all of the above, we recommend that the total suction head not exceed 25'.

2. An excessively worn impeller is mainly caused by a number of situations, such as:

- Restricted suction.
- Excessive suction lift.

3. The seal may be damaged due to:

- Normal wear.
- Overheating.
- Pumping chemicals that this seal is not designed for.

Contact an authorized service depot for further assistance.

# GLOSSARY OF TERMS

**Air volume control**

Designed to maintain the air charge in a standard water storage tank. Pre-charged tanks do not require an air volume control.

**Atmospheric pressure**

A force exerted upon the earth's surface by the weight of air extending to a height of 25 miles above the earth; 14.7 pounds per square inch at sea level.

**Barb fitting**

A part of a fitting that a hose slides over which contains ridges, which help lock the hose to the fitting. The hose is then secured with a clamp.

**Basin**

A container connected to a sink, toilet, washer, or dishwasher that is used to collect refuse that comes from these appliances. Once collected, the waste is pumped from the basin to a septic tank, holding tank, leaching field, or septic field. See Minimum Basin Diameter for additional information.

**Black water**

Also known as sewage or wastewater. Water containing semi-solids up to 2 inches in diameter.

**Centrifugal force**

The force created by a spinning or rotating impeller resulting in the movement of water outward from the center point. A pump uses an impeller to create centrifugal force.

**Check valve**

Allows water to move in only one direction which prevents water from returning to its source.

**Control box**

Installs above ground. Contains electrical starting components for 3-wire submersible deep well pumps. 2-wire submersible deep well pumps do not use a control box.

**Convertible jet pump**

For both deep wells (where pumping water levels are as far as 90' below the pump) and shallow wells (where pumping water levels are no more than 25' below the pump). Pump/tank packages are also available.

**Cut-in pressure setting**

The point at which the pressure switch turns the pump on.

**Deep well**

Well with a depth to water greater than 25'.

**Deep well pump (submersible)**

For use on wells where pump water levels are up to 400' below point of use. Pump is submerged underwater in the well.

**Depth to water**

The vertical measurement from pump level down to water level of water source. Pump height above water.

**Discharge**

The opening by which water is removed by the pump.

**Discharge pressure**

The amount of force or pressure of the water being discharged from the pump.

**Dual voltage motor**

Pump motor can then be operated on 115 Volts or 230 Volts.

**Effluent**

Water containing semi-solids up to 1/2" diameter generated from activities such as dishwashing, bathing, laundry, etc., also known as gray water.

**FNPT**

Female National Pipe Thread: a U.S. standard for tapered threads used on threaded pipes and fittings (female end is larger than male end).

**Foot valve**

Installs on the end of the suction pipe to prevent water from draining back to source. Includes strainer to minimize suction of debris into the pump.

# GLOSSARY OF TERMS

**Friction loss**

A loss in pressure caused by friction when liquid moves through a pipe.

**GHT**

Garden Hose Thread (3/4").

**GPH**

Gallons per hour.

**GPM**

Gallons per minute.

**Gray water**

Also known as effluent. Water containing semi-solids up to 1/2" in diameter generated from activities such as dishwashing, bathing, laundry, etc.

**Head**

The vertical distance from the top of the well to the pressure tank, the top of the well to the static water level, the drawdown (static water level to the pumping water level), or the vertical distance from the well to the house

**HP**

Horsepower (power of motor)

**Intake**

The opening by which water is sucked into the pump.

**Jet pump**

A centrifugal pump that requires a jet to help build additional water pressure.

**Minimum basin diameter**

Minimum basin diameter refers to the inside diameter of the opening at the top of a basin not including the lip. It is a guideline based on average basin sizes in the industry. Minimum clearance dimensions are not provided because most basins are tapered at the bottom and it can be difficult to measure this accurately. Place the pump so the switch can move freely without touching the basin (the pump edge should be up against the side of the basin). Always test the pump to make sure the switch clears the side wall of the basin. If you have a narrow pit or basin less than 18" in diameter, a pump with a vertical or snap-action float switch is recommended.

**MNPT**

Male National Pipe Thread: a U.S. standard for tapered threads used on threaded pipes and fittings (male end is smaller than female end).

**Multi-stage jet pump**

For use on deep wells only with pumping water levels as far as 210' below the pump.

**NPT**

National Pipe Thread: a U.S. standard for tapered threads used on threaded pipes and fittings.

**PSI**

Pounds per square inch. A volumetric pressure measurement.

**Pre-charged tank**

A water storage tank pre-charged with air at the factory featuring a vinyl bag to separate water from the air which prevents waterlogging. This tank design provides greater drawdown than standard tanks. Pre-charged tanks do not require an air volume control.

**Pressure**

A force usually expressed in pounds per square inch.

**Pressure switch**

The switch that automatically turns the pump on and off at specified pressures of 30/50 psi and 40/60 psi.

**IMPORTANT:** Always replace an old switch with a new switch with the same pressure settings.

**Pressure operation - 30/50**

Pressure switch turns pump on at 30 psi and off at 50 psi.

# GLOSSARY OF TERMS

**Pressure operation - 40/60**

Pressure switch turns pump on at 40 psi and off at 60 psi.

**Priming the pump**

The initial filling of a jet or centrifugal pump with water so that air can be removed.

**Pump capacity**

The amount of water a pump is capable of moving at a given pressure.

**Pumping water level**

The distance below ground where the water is found when the well is being pumped at its rated capacity.  
Static Water Level + Drawdown = Pumping Water Level.

**Safety relief valve**

Required for all submersible pump and pressure boosting installations to prevent over-pressurization of water storage tank and system piping that could develop from pressure switch malfunction.

**Sewage**

Water containing semi-solids up to 2" in diameter. Also known as black water.

**Shallow well**

Well with a depth of water of 25' or less.

**Shallow well pump**

For use in wells where pump water levels are no more than 25' below the pump. Features a built-in jet.

**Sizing**

Properly matching product to application for best performance.

**Standard tank**

A pressurized water storage tank where air comes in contact with water. Requires air volume control for proper operation.

**Static water level**

The distance below ground where water is found when no pumping occurs.

**Submersible deep well pump**

For use on wells where pump water levels are up to 400' below point of use. Pump is submerged underwater in the well.

**Suction lift**

The vertical height from the pumping water level to the suction part of the pump.

**Tank**

Stores air and water under pressure to provide for automatic pump operation and a source of water when pump is not running.

**TEFC design**

Totally enclosed, fan cooled design.

**Waterlogging**

The absorption of air into water stored in a water storage tank, greatly reducing the amount of usable water drawdown available from the tank.

**Water storage tank**

Stores air and water under pressure to provide for automatic pump operation and a source of water when pump is not running.

**Well capacity**

Also known as the well's replenishment rate or well recovery rate. It is the rate at which the well refills with water, measured in gpm. This information is found on the Well Driller's Report.

**Well recovery rate or well replenishment rate**

Also known as the well's replenishment rate or well capacity. It is the rate at which the well refills with water, measured in gpm. This information is found on the Well Driller's Report.

# TECHNICAL DATA

## FRICTION LOSS CHART

Nom. Pipe Size Material I.D./US GPM	3/4"			1"			1-1/4"			1-1/2"			2"		
	Steel	Copper	Plastic	Steel	Copper	Plastic	Steel	Copper	Plastic	Steel	Copper	Plastic	Steel	Copper	Plastic
1	0.824	0.822	0.824	1.049	1.062	1.049	1.38	1.368	1.38	1.61	1.6	1.61	2.067	2.062	2.067
2	1.93	1.21	1.04	0.6	0.35	0.32									
2.5	2.91	1.82	1.57	0.92	0.55	0.48									
3	4.08	2.56	2.21	1.26	0.73	0.68									
3.5	5.42	3.4	2.93	1.7	1	0.9									
4	6.94	4.36	3.74	2.14	1.24	1.15	0.56	0.36	0.3	0.27	0.17	0.14			
4.5	8.63	5.4	4.66	2.68	1.58	1.45	0.69	0.42	0.39	0.34	0.21	0.18			
5	10.5	6.57	5.66	3.42	1.88	1.75	0.85	0.55	0.46	0.41	0.25	0.22			
5.5	12.4	7.79	6.75	3.9	2.3	2.1	1	0.62	0.53	0.49	0.3	0.26			
6	14.7	9.22	7.95	4.54	2.63	2.45	1.2	0.77	0.65	0.57	0.36	0.31			
6.5	17	10.7	9.25	5.3	3.12	2.84	1.38	0.88	0.72	0.66	0.42	0.36			
7	19.6	12.2	10.6	6.08	3.58	3.25	1.59	1.02	0.86	0.76	0.48	0.41			
7.5	22.3	13.9	12	6.92	4.03	3.68	1.82	1.16	0.98	0.86	0.54	0.46			
8	25	15.7	13.5	7.73	4.5	4.16	2.04	1.31	1.1	0.96	0.61	0.52			
8.5	27.9	17.6	15.1	8.76	5.08	4.62	2.3	1.47	1.21	1.07	0.68	0.58			
9	31.1	19.5	16.8	9.72	5.6	5.17	2.55	1.62	1.35	1.19	0.75	0.65			
9.5	34.5	21.6	18.6	10.7	6.18	5.72	2.82	1.79	1.5	1.32	0.83	0.72			
10	37.8	23.7	20.4	11.7	6.77	6.31	3.08	1.98	1.67	1.45	0.92	0.79	0.43	0.27	0.23
11	45.1	28.2	24.4	14.1	8.08	7.58	3.7	2.32	1.98	1.74	1.1	0.95	0.51	0.32	0.27
12	53	33.2	28.6	16.4	9.47	8.85	4.31	2.75	2.33	2.04	1.29	1.1	0.6	0.37	0.32
13	61.5	38.5	33.2	18.9	11	10.3	5.01	3.18	2.71	2.37	1.49	1.28	0.7	0.43	0.37
14	70.5	44.2	38	21.8	12.6	11.8	5.73	3.64	3.1	2.71	1.71	1.46	0.8	0.49	0.43
16	90.2	56.6	48.6	27.9	16.2	15.1	7.34	4.68	3.96	3.47	2.2	1.87	1.03	0.63	0.55
18	112	70.4	60.5	34.7	20.1	18.7	9.13	5.81	4.93	4.31	2.75	2.33	1.28	0.78	0.69
20	136	83.5	73.5	42.1	24.4	22.8	11.1	7.1	6	5.24	3.31	2.83	1.55	0.96	0.84
25				63.9	36.9	34.6	16.8	10.7	9.06	7.9	5	4.26	2.35	1.45	1.27
30				89.2	51.6	48.1	23.5	15	12.7	11.1	7	6	3.29	2.03	1.78
35				119	68.7	64.3	31.2	20	16.9	14.7	9.35	7.94	4.37	2.71	2.36
40				152	88	82	40	25.6	21.6	18.9	12	10.2	5.6	3.47	3.03
45				189	109	102	49.4	31.9	27	23.4	14.9	12.6	6.96	4.31	3.76
50							60.4	38.7	32.6	28.5	18.1	15.4	8.46	5.24	4.57
55							71.9	46.5	39.1	34	21.5	18.4	10.1	6.22	5.46
60							84.7	54.1	45.6	40	25.3	21.6	11.9	7.34	6.44
65							99.1	63	53.4	46.4	29	25.1	13.8	8.5	7.42
70							114	72.2	61.5	53.2	33.8	28.7	15.8	9.78	8.53
75							129	82.1	69.4	60.4	38	32.6	17.9	11.1	9.68
80							144	92.4	77.9	68.1	43.1	36.8	20.2	12.5	10.9
85							161	104	87	76.2	47.6	41.2	22.5	14	12.2
90							179	115	96.6	84.7	53.6	45.7	25.1	15.6	13.6
95										93.6	58.8	50.5	27.8	17.2	15

NOTE: Loss of head in feet due to friction per 100 feet of pipe (Based on C = 100 for steel, C = 130 for copper, and C = 140 for plastic)

## CABLE SELECTION FOR DEEP WELL SUBMERSIBLES

### Canadian

Cable selection based on a 3% voltage drop, two- or three-wire cable, 60 Hz.

Motor HP	Volts	(AWG) Copper Wire Size		
		14	12	10
1/2	115	60	95	150
	230	240	390	610
3/4	230	180	285	455
1	230	150	240	375
1-1/2	230	115	185	285

### U.S.A.

Cable selection based on a 5% voltage drop, two- or three-wire cable, 60 Hz.

Motor HP	Volts	(AWG) Copper Wire Size		
		14	12	10
1/2	115	100	160	250
	230	400	650	1020
3/4	230	300	480	760
1	230	250	400	630
1-1/2	230	190	310	480

# INDEX OF ITEMS NUMERICALLY BY ITEM NUMBER

Item No.	Model	Description	Page No.
14942003	MPDP	Drill powered transfer pump	40
14942004	MPFV12	12 VDC, 300 gph utility transfer pump	36
14942006	MPTC	1250 gph multi-purpose transfer pump	38
14942008	MPFV12CAMO	12 VDC vehicle outlet, 300 gph camo multi-purpose pump	37
14942015	MPFVK115	115 V, 365 gph multi-purpose transfer pump	36
14942050	SP33PED	1/3 hp, 3300 gph thermoplastic pedestal sump pump	22
14942051	SC33PED	1/3 hp, 3500 gph cast iron pedestal sump pump	22
14942401	RL12G05-2W1V	1/2 hp, 12 gpm, 2-wire, 115 V, 4" deep well submersible pump	9
14942402	RL12G05-2W2V	1/2 hp, 12 gpm, 2-wire 230 V, 4" deep well submersible pump	9
14942403	RL12G07-2W2V	3/4 hp, 12 gpm, 2-wire, 230 V, 4" deep well submersible pump	9
14942404	RL12G10-2W2V	1 hp, 12 gpm, 2-wire, 230 V, 4" deep well submersible pump	9
14942405	RL12G05-3W2V	1/2 hp, 12 gpm, 3-wire, 230 V, 4" deep well submersible pump	9
14942406	RL12G07-3W2V	3/4 hp, 12 gpm, 3-wire, 230 V, 4" deep well submersible pump	9
14942407	RL12G10-3W2V	1 hp, 12 gpm, 3-wire, 230 V, 4" deep well submersible pump	9
14942408	RL12G15-3W2V	1.5 hp, 12 gpm, 3-wire, 230 V, 4" deep well submersible pump	9
14942409	RL22G10-3W2V	1.0 hp, 22 gpm, 3-wire, 230 V, 4" deep well submersible pump	9
14942601	C20ST	82 gph condensate removal pump kit - 20' lift, w/tubing	41
14942635	RL75WAM	3/4 hp, 10500 gph premium cast iron sewage pump	30
14942652	RL-33SC	1/3 hp, 3200 gph snap-action cast iron sump/effluent pump	20 & 26
14942653	RL-50SC	1/2 hp, 4000 gph snap-action cast iron sump/effluent pump	20 & 26
14942663	RL50WA	1/2 hp, 7200 gph cast iron sewage pump w/tethered float switch	29
14942722	RL50CON	1/2 hp, 3600 gph heavy-duty submersible utility pump	42
14942731	RL-MP16	1/6 hp, 1300 gph thermoplastic utility pump	33
14942732	RL-MP25	1/4 hp, 2200 gph thermoplastic utility pump	33
14942734	RL-250U	1/4 hp, 1500 gph aluminum utility pump	34
14942735	RL-MP25A	1/4 hp, 2200 gph automatic utility pump	35
14942736	RL-SPS33	1/3 hp, 3200 gph under-sink sump package w/6 gal. basin	23
14942739	RL-SP25T	1/4 hp, 2900 gph thermoplastic sump pump w/tethered float switch	17
14942740	RL-SP33T	1/3 hp, 3200 gph thermoplastic sump pump w/tethered float switch	17
14942741	RL-SP33V	1/3 hp, 3200 gph thermoplastic sump pump w/vertical float switch	17
14942742	RL-SP50T	1/2 hp, 3600 gph thermoplastic sump pump w/tethered float switch	17
14942743	RL-SP50V	1/2 hp, 3600 gph thermoplastic sump pump w/vertical float switch	17
14942744	RL-SC33T	1/3 hp, 3350 gph cast iron sump pump w/tethered float switch - 1/2" semi-solids	18
14942745	RL-SC33V	1/3 hp, 3350 gph cast iron sump pump w/vertical float switch - 1/2" semi-solids	18
14942746	RL-SC50T	1/2 hp, 4300 gph cast iron sump pump w/tethered float switch - 1/2" semi-solids	18
14942747	RL-SC50V	1/2 hp, 4300 gph cast iron sump pump w/vertical float switch - 1/2" semi-solids	18
14942748	RL-WC50TA	1/2 hp, 5600 gph cast iron sewage pump w/tethered float switch	29
14942749	RL-WC50TA	1/2 hp, 5600 gph cast iron sewage pump w/tethered switch, plastic check valve, includes basin	32
14942756	RL-WC50TA-24	1/2 hp, 5600 gph cast iron sewage pump w/tethered switch, cast iron check valve, includes basin	32
14942771	RL-SC33DUP	1/3 hp dual cast iron sump pump system	19
14942780	RL-SS50V	1/2 hp, 3450 gph, premium stainless steel sump pump w/vertical float switch	21
14942781	RL-SS50T	1/2 hp, 3450 gph, premium stainless steel sump/effluent pump w/tethered float switch	21 & 27
14942782	RL-SS100T	1 hp, 5300 gph, premium stainless steel sump/effluent pump w/tethered float switch	21 & 27
14942792	RL-SPBS	Battery backup sump system	24
14942793	RL33CSS	1/3 hp, 3500 gph stainless steel sump pump w/snap-action float switch	18
14942794	RL50CSS	1/2 hp, 3900 gph stainless steel sump pump w/snap-action float switch	18
14942795	RL75CSS	3/4 hp, 4500 gph stainless steel sump pump w/snap-action float switch	18
602038	RJC-100	1 hp high performance cast iron convertible jet pump	6
602099	RJS-50/RL6H	1/2 hp, 5.3 gal. shallow well jet pump & tank system	8
602102	RJC-50/RL6H	1/2 hp, 5.3 gal. convertible jet pump & tank system	8

# INDEX OF ITEMS NUMERICALLY BY ITEM NUMBER

Item No.	Model	Description	Page No.
602136	RJC-50-PREM	1/2 hp premium cast iron convertible jet pump	5
602137	RJC-75-PREM	3/4 hp premium cast iron convertible jet pump	5
602206	RJS-50-PREM	1/2 hp premium shallow well jet pump	2
602207	RJS-75-PREM	3/4 hp premium shallow well jet pump	2
602208	RJS-100-PREM	1 hp premium shallow well jet pump	2
604452	RL2	2.1 gal. inline pre-charged pressure tank	7
604453	RL4	4.8 gal. inline pre-charged pressure tank	7
604454	RL8	8.5 gal. inline pre-charged pressure tank	7
604493	RL14H	14 gal. horizontal pre-charged pressure tank	7
604529	RL6H	5.3 gal. horizontal pre-charged pressure tank	7
604531	RL119	119 gal. vertical pre-charged pressure tank	7
604541	RL81	81 gal. vertical pre-charged pressure tank	7
604581	RL20H	21.1 gal. horizontal pre-charged pressure tank	7
604582	RL21	21.1 gal. vertical pre-charged pressure tank	7
604583	RL34	34.3 gal. vertical pre-charged pressure tank	7
604584	RL40	40.0 gal. vertical pre-charged pressure tank	7
604587	RL16	15.9 gal. vertical pre-charged pressure tank	7
614430	RJSE-50	1/2 hp, 115 V cast iron sprinkler utility pump	13
614432	RJSE-75SS	3/4 hp, 115 V stainless steel sprinkler utility pump	14
614481	RLHE-300	3 hp cast iron industrial sprinkler pump	16
617030	5RLAG-2LKIT	179cc OHV engine drive, 2" aluminum water transfer pump kit	46
617031	2RLAG-1L	79cc OHV engine drive, 1.5" aluminum water transfer pump	43
617032	5RLGF-8KRF	196cc OHV engine drive, 2" cast iron transfer pump	47
617033	5RLAG-2L	179cc OHV engine drive, 2" aluminum water transfer pump	45
617034	6RLAG-2LST	208cc OHV engine drive, aluminum semi-trash pump, 2" MNPT	50
617037	6RLAG-3LST	208cc OHV engine drive, aluminum semi-trash pump, 3" MNPT	50
617038	6RLAG-3LTT	208cc OHV engine drive, aluminum trash pump, 3" NPT	52
617041	6RLAG-3HST	163cc Honda engine drive, aluminum semi-trash pump, 3" MNPT	51
617053	4RLAG-2H	118cc Honda engine drive, 2" aluminum water transfer pump	44
617070	6RLPG-2U	212cc OHV engine drive, thermoplastic ag chemical & transfer pump, 2" x 2" FNPT	48
617071	6RLPG-2K	196cc Kohler 3000 series engine drive, thermoplastic ag chemical & transfer pump, 2" x 2" FNPT	49
620040	RL31EA	1/3 hp, 6300 gph heavy-duty cast iron effluent pump	28
620051	RL52WAM	1/2 hp, 9000 gph premium cast iron sewage pump w/tethered switch	30
620109	RL-160U	1/6 hp, 1300 gph aluminum utility pump	34
621810	RL-S50	1/2 hp, 2700 gph cast iron surface effluent pump	25
640188	RLCB05-115	Control box, 1/2 hp, 115 V	10
640189	RLCB05-230	Control box, 1/2 hp, 230 V	10
640190	RLCB07-230	Control box, 3/4 hp, 230 V	10
640191	RLCB10-230	Control box, 1 hp, 230 V	10
640222	RLCB15-230	Control box, 1.5 hp, 230 V	10
97080502	RL-SWJ50	1/2 hp cast iron shallow well jet pump	3
97080503	RL-SWJ50/RL6H	1/2 hp, 5.8 gal. shallow well jet pump & tank system	8
97080701	RL-SWJ75	3/4 hp cast iron shallow well jet pump	3
97080702	RJS-75SS	3/4 hp stainless steel shallow well jet pump	4
97081001	RL-SWJ100	1 hp cast iron shallow well jet pump	3
97101001	RL-SPRK100	1 hp sprinkler pump	15
97101501	RL-SPRK150	1.5 hp sprinkler pump	15
97102001	RL-SPRK200	2 hp sprinkler pump	15
97101502	RL-SPRK150-BR	1.5 hp sprinkler pump, brass impeller	15
97102002	RL-SPRK200-BR	2 hp centrifugal sprinkler pump, brass impeller	15

# INDEX OF ITEMS ALPHABETICALLY BY MODEL

Model	Item No.	Description	Page No.
2RLAG-1L	617031	79cc OHV engine drive, 1.5" aluminum water transfer pump	43
4RLAG-2H	617053	118cc Honda engine drive, 2" aluminum water transfer pump	44
5RLAG-2L	617033	179cc OHV engine drive, 2" aluminum water transfer pump	45
5RLAG-2LKIT	617030	179cc OHV engine drive, 2" aluminum water transfer pump kit	46
5RLGF-8KRF	617032	196cc OHV engine drive, 2" cast iron transfer pump	47
6RLAG-2LST	617034	208cc OHV engine drive, aluminum semi-trash pump, 2" MNPT	50
6RLAG-3HST	617041	163cc Honda engine drive, aluminum semi-trash pump, 3" MNPT	51
6RLAG-3LST	617037	208cc OHV engine drive, aluminum semi-trash pump, 3" MNPT	50
6RLAG-3LTT	617038	208cc OHV engine drive, aluminum trash pump, 3" NPT	52
6RLPG-2K	617071	196cc Kohler 3000 series engine drive, thermoplastic ag chemical & transfer pump, 2" x 2" FNPT	49
6RLPG-2U	617070	212cc OHV engine drive, thermoplastic ag chemical & transfer pump, 2" x 2" FNPT	48
C2OST	14942601	82 gph condensate removal pump kit - 20' lift, w/tubing	41
MPDP	14942003	Drill powered transfer pump	40
MPFV12	14942004	12 VDC, 300 gph utility transfer pump	36
MPFVK115	14942015	115 V, 365 gph multi-purpose transfer pump	36
MPFV12CAMO	14942008	12 VDC vehicle outlet, 300 gph camo multi-purpose pump	37
MPTC	14942006	1250 gph multi-purpose transfer pump	38
RJC-100	602038	1 hp high performance cast iron convertible jet pump	6
RJC-50/RL6H	602102	1/2 hp, 5.3 gal. convertible jet pump & tank system	8
RJC-50-PREM	602136	1/2 hp premium cast iron convertible jet pump	5
RJC-75-PREM	602137	3/4 hp premium cast iron convertible jet pump	5
RJS-100-PREM	602208	1 hp premium shallow well jet pump	2
RJS-50-PREM	602206	1/2 hp premium shallow well jet pump	2
RJS-50/RL6H	602099	1/2 hp, 5.3 gal. shallow well jet pump & tank system	8
RJS-75-PREM	602207	3/4 hp premium shallow well jet pump	2
RJS-75SS	97080702	3/4 hp stainless steel shallow well pump	4
RJSE-50	614430	1/2 hp, 115 V cast iron sprinkler utility pump	13
RJSE-75SS	614432	3/4 hp, 115 V stainless steel sprinkler utility pump	14
RL-160U	620109	1/6 hp, 1300 gph aluminum utility pump	34
RL-250U	14942734	1/4 hp, 1500 gph aluminum utility pump	34
RL-33SC	14942652	1/3 hp, 3200 gph snap-action cast iron sump/effluent pump	20 & 26
RL-50SC	14942653	1/2 hp, 4000 gph snap-action cast iron sump/effluent pump	20 & 26
RL-MP16	14942731	1/6 hp, 1300 gph thermoplastic utility pump	33
RL-MP25	14942732	1/4 hp, 2200 gph thermoplastic utility pump	33
RL-MP25A	14942735	1/4 hp, 2200 gph automatic utility pump	35
RL-S50	621810	1/2 hp, 2700 gph cast Iron surface effluent pump	25
RL-SC33DUP	14942771	1/3 hp, dual cast iron sump pump system	19
RL-SC33T	14942744	1/3 hp, 3350 gph cast iron sump pump w/tethered float switch - 1/2" semi-solids	18
RL-SC33V	14942745	1/3 hp, 3350 gph cast iron sump pump w/vertical float switch - 1/2" semi-solids	18
RL-SC50T	14942746	1/2 hp, 4300 gph cast iron sump pump w/tethered float switch - 1/2" semi-solids	18
RL-SC50V	14942747	1/2 hp, 4300 gph cast iron sump pump w/vertical float switch - 1/2" semi-solids	18
RL-SP25T	14942739	1/4 hp, 2900 gph thermoplastic sump pump w/tethered float switch	17
RL-SP33T	14942740	1/3 hp, 3200 gph thermoplastic sump pump w/tethered float switch	17
RL-SP33V	14942741	1/3 hp, 3200 gph thermoplastic sump pump w/vertical float switch	17
RL-SP50T	14942742	1/2 hp, 3600 gph thermoplastic sump pump w/tethered float switch	17
RL-SP50V	14942743	1/2 hp, 3600 gph thermoplastic sump pump w/vertical float switch	17
RL-SPBS	14942792	Battery backup sump system	24
RL-SPS33	14942736	1/3 hp, 3200 gph under-sink sump package w/6 gal. basin	23
RL-SSI00T	14942782	1 hp, 5300 gph, premium stainless steel sump/effluent pump w/tethered float switch	21 & 27
RL-SS50T	14942781	1/2 hp, 3450 gph, premium stainless steel sump/effluent pump w/tethered float switch	21 & 27

# INDEX OF ITEMS ALPHABETICALLY BY MODEL

Model	Item No.	Description	Page No.
RL-SS50V	14942780	1/2 hp, 3450 gph, premium stainless steel sump pump w/vertical float switch	21
RL-SWJ100	97081001	1 hp shallow well jet pump	3
RL-SWJ50	97080502	1/2 hp cast iron shallow well jet pump	3
RL-SWJ50/RL6H	97080503	1/2 hp, 5.8 gal. shallow well jet pump & tank system	8
RL-SWJ75	97080701	3/4 hp cast iron shallow well jet pump	3
RL-WC50TA	14942748	1/2 hp, 5600 gph cast iron sewage pump w/tethered float switch	29
RL-WCS50TA	14942749	1/2 hp, 5600 gph cast iron sewage pump w/tethered switch, plastic check valve, includes basin	32
RL-WCS50TA-24	14942756	1/2 hp, 5600 gph cast iron sewage pump w/tethered switch, cast iron check valve, includes basin	32
RL119	604531	119 gal. vertical pre-charged pressure tank	7
RL12G05-2W1V	14942401	1/2 hp, 12 gpm, 2-wire, 115 V, 4" deep well submersible pump	9
RL12G05-2W2V	14942402	1/2 hp, 12 gpm, 2-wire 230 V, 4" deep well submersible pump	9
RL12G05-3W2V	14942405	1/2 hp, 12 gpm, 3-wire, 230 V, 4" deep well submersible pump	9
RL12G07-2W2V	14942403	3/4 hp, 12 gpm, 2-wire, 230 V, 4" deep well submersible pump	9
RL12G07-3W2V	14942406	3/4 hp, 12 gpm, 3-wire, 230 V, 4" deep well submersible pump	9
RL12G10-2W2V	14942404	1 hp, 12 gpm, 2-wire, 230 V, 4" deep well submersible pump	9
RL12G10-3W2V	14942407	1 hp, 12 gpm, 3-wire, 230 V, 4" deep well submersible pump	9
RL12G15-3W2V	14942408	1.5 hp, 12 gpm, 3-wire, 230 V, 4" deep well submersible pump	9
RL14H	604493	14 gal. horizontal pre-charged pressure tank	7
RL16	604587	15.9 gal. vertical pre-charged pressure tank	7
RL2	604452	2.1 gal. inline pre-charged pressure tank	7
RL20H	604581	21.1 gal. horizontal pre-charged pressure tank	7
RL21	604582	21.1 gal. vertical pre-charged pressure tank	7
RL22G10-3W2V	14942409	1.0 hp, 22 gpm, 3-wire, 230 V, 4" deep well submersible pump	9
RL3IEA	620040	1/3 hp, 6300 gph heavy-duty cast iron effluent pump	28
RL33CSS	14942793	1/3 hp, 3500 gph stainless steel sump pump w/snap-action float switch	18
RL50CSS	14942794	1/2 hp, 3900 gph stainless steel sump pump w/snap-action float switch	18
RL75CSS	14942795	3/4 hp, 4500 gph stainless steel sump pump w/snap-action float switch	18
RL34	604583	34.3 gal. vertical pre-charged pressure tank	7
RL4	604453	4.8 gal. inline pre-charged pressure tank	7
RL40	604584	40.0 gal. vertical pre-charged pressure tank	7
RL50CON	14942722	1/2 hp, 3600 gph heavy-duty submersible utility pump	42
RL50WA	14942663	1/2 hp, 7200 gph cast iron sewage pump w/tethered float switch	29
RL52WAM	620051	1/2 hp, 9000 gph premium cast iron sewage pump w/tethered switch	30
RL6H	604529	5.3 gal. horizontal pre-charged pressure tank	7
RL75WAM	14942635	3/4 hp, 10500 gph premium cast iron sewage pump	30
RL8	604454	8.5 gal. inline pre-charged pressure tank	7
RL81	604541	81 gal. vertical pre-charged pressure tank	7
RLCB05-115	640188	Control box, 1/2 hp, 115 V	10
RLCB05-230	640189	Control box, 1/2 hp, 230 V	10
RLCB07-230	640190	Control box, 3/4 hp, 230 V	10
RLCB10-230	640191	Control box, 1 hp, 230 V	10
RLCB15-230	640222	Control box, 1.5 hp, 230 V	10
RLHE-300	614481	3 hp cast iron industrial sprinkler pump	16
RL-SPRK100	97101001	1 hp sprinkler pump	15
RL-SPRK150	97101501	1.5 hp sprinkler pump	15
RL-SPRK150-BR	97101502	1.5 hp sprinkler pump, brass impeller	15
RL-SPRK200	97102001	2 hp sprinkler pump	15
RL-SPRK200-BR	97102002	2 hp sprinkler pump, brass impeller	15
SC33PED	14942051	1/3 hp, 3500 gph cast iron pedestal sump pump	22
SP33PED	14942050	1/3 hp, 3300 gph thermoplastic pedestal sump pump	22



**RED LION**®

[redlionproducts.com](http://redlionproducts.com)

**Technical Service Line:  
1.888.885.9254**

US Address: 301 N. MacArthur Blvd. | Oklahoma City, OK | 73127-6616 | U.S.A.

07-19 FORM # 996508 REV. 012